

HISUN

GRAB SOME SUN

Published by Chongqing
Huansong Industries
(Group) Co., Ltd and
Hisun Motors Corp USA.

Chongqing Huansong
Industries (Group) Co., Ltd
and Hisun Motors Corp USA
holds the copy right.
No publishing and reprinting
without permission.

READ THIS MANUAL CAREFULLY

For questions regarding this
UTV, please contact HISUN at:
(972)446-0760
hisunmotors.com

Rev. 01031701

No one under the age of 16
should operate this vehicle.

Provincial / Municipal
governments have different
regulations pertaining to
owning and operating an
off-road vehicle; learn the
regulations in your area.



VECTOR 500

OWNER'S MANUAL

INTRODUCTION

Congratulations on your purchase of the Vector 500. This Owner's / Operator's manual will provide you information regarding safe operation, operational instructions, maintenance and care. Fully understanding this manual and following all of the instructions herein will provide the knowledge needed to have safe and enjoyable UTV operation.

For questions regarding this UTV, please call (972) 446-0760.

IMPORTANT SAFETY MESSAGES

- **READ THIS MANUAL CAREFULLY AND COMPLETELY BEFORE OPERATING YOUR UTV. MAKE SURE YOU UNDERSTAND ALL INSTRUCTIONS.**
- **PAY CLOSE ATTENTION TO THE WARNING AND CAUTION LABELS ON THE UTV.**
- **NEVER OPERATE THE UTV WITHOUT PROPER TRAINING OR INSTRUCTION.**
- **THIS UTV SHOULD NOT BE RIDDEN BY ANYONE UNDER 16 YEARS OF AGE.**

IMPORTANT MANUAL INFORMATION

FAILURE TO FOLLOW THE WARNINGS CONTAINED IN THIS MANUAL CAN RESULT IN SERIOUS INJURY

OR DEATH. Particularly important information is distinguished in this manual by the following notations:



The Safety Alert Symbol means **ATTENTION!**
YOUR SAFETY IS INVOLVED!



Failure to follow **WARNING** instructions could result in severe injury or death to the machine operator, bystander or a person inspecting or repairing the machine.



A **CAUTION** indicates special precautions that must be taken to avoid damage to the machine.

NOTE: A **NOTE** provides key information to make procedures easier clearer.

IMPORTANT NOTICE

This UTV is designed and manufactured for **OFF - ROAD** use only. It is illegal and unsafe to operate this UTV on any public street, road or highway.

This UTV complies with all applicable **OFF - ROAD** noise level and spark arrester laws and regulations in effect at the time of manufacture.

Please check your local riding laws and regulations before operating this UTV.

When the temperature is below -4°F (-20°C), park the UTV in a place where the temperature is higher than -4°F (-20°C). Start the UTV after the UTV has warmed up. Please see page 7-3 on the warming up process.

Follow the proper parking procedures when the temperature is higher than 100°F (38°C): turn off the engine; make sure the radiator fan is on for 3 minutes before turning off the power switch.

Starting the UTV for the first time will take longer because the fuel will need reach the fuel injectors. To start the UTV the first time, hold the ignition key on at 5-second intervals. Allow the starter to rest 15 seconds between each start attempt.

UNIVERSAL SYMBOLS

As a guide to the operation of your vehicle, various universal symbols have been utilized on the instruments and controls. The symbols are shown below with an indication of their meaning.



Safety Alert Symbol



Diesel Fuel



Engine coolant-Temperature



Parking Brake



Battery Charging Condition



Engine Oil-Pressure



Turn Signal/Hazard



Differential Lock



Position light bulb



Lift Cylinder-Retract



Lift Cylinder-Extend



Lift Cylinder-Float



Hazard Warning Lights



Master Lighting Switch



Audible Warning Device



Fault indicator light of EPS system



2WD/ 4WD

Table of Contents

<u>Subject</u>	<u>Page</u>		
Safe Operation	1-1	Coolant temperature gauge	8-5
Children safety Instruction	1-2	Hour Meter and Fuel gauge	8-6
Driving on a slope/high speeds	1-3	Winch mount plate	9-1
Parking and Transportation	1-4	Service interval chart	10-1
Warning labels	1-5	Periodic Service	11-1
Servicing of Vehicle ID Numbers	2-1	How to open the front hood and seat	11-1
Specifications	3-1	Front hood cover	11-1
Vehicle Limitations	4-1	Operator's seat	11-1
Instrument Panels and Controls	5-1	How to raise the cargo bed	11-1
Pre-operation Checks	6-1	Raising and Lowering the Cargo Bed	11-1
Driving on a slope	2-3	Jack-up point	11-2
Operating the engine	7-1	Front end	11-2
Starting the engine	7-1	Rear end	11-2
Cold starting	7-2	Daily check	11-3
Stopping the engine	7-2	Checking and Refueling	11-3
Warming up	7-2	Checking coolant level	11-4
Warm-up transmission oil in the low temperature range	7-3	Cleaning radiator screen	11-4
Warning and caution labels	3-1	Checking brake fluid level	11-5
Operating the vehicle	8-1	Checking brake pedal	11-5
Operating new vehicle	8-1	Checking parking brake	11-5
Do not operate the vehicle at full speed for the first 50 hours	8-1	Checking gauges meter	11-5
Changing lubricating oil for new vehicles	8-1	Checking head light turn signal light etc	11-5
Starting	8-1	Checking seat belt and ROPS	11-5
Seat belt	8-2	Checking joint boot	11-5
Head light switch	8-2	Checking tire inflation pressure	11-6
Emergency light switch	8-2	Every 50 hours	11-6
Turn signal light switch	8-2	Greasing	11-6
Brake pedal	8-3	Checking engine start system	11-7
Range gear shift lever	8-4	Checking wheel bolt torque	11-7
Parking Brake	8-4	Cleaning air cleaner primary element	11-7
Accelerator pedal	8-4	Evacuation valve	11-8
Stopping	8-5	Fuel Lines	11-9
		Checking Battery Condition	11-9
		Storage	11-10
		Adjusting toe-in	11-10
		Cleaning muffler	11-10

200 Hour Maintenance	11-11	Replacing brake master cylinder (inner parts)	11-17
Changing the oil	11-11	Replacing front brake seal	11-17
Replacing the oil	11-11	Replacing rear brake cylinder seal	11-17
Replacing transmission oil	11-12	Replacing intake air line	11-17
Checking brake pedal	11-12	Every 4 years	11-17
Checking brake hose and pipe	11-13	Replacing brake hose	11-17
Checking brake light switch	11-13	Replacing slow-blow fuses	11-17
Checking radiator hose and clamp	11-13	Replacing light bulb	11-18
Checking intake air line	11-14	Vehicle storage	12-1
Every 300 hours	11-14	Removing the vehicle from storage	12-2
Checking tire	11-14	Troubleshooting	13-1
Every 400 hours	11-14	Engine troubleshooting	13-1
Changing transmission fluid	11-14	Diagnostic trouble code table	13-2
Changing front and rear axle case oil	11-14	Battery troubleshooting	13-3
Every 500 hours	11-15	Machine troubleshooting	13-4
Replacing fuel filter	11-15	Options	14-1
Every 600 hours	11-15	Vehicle Warranty	15-1
Adjusting engine valve clearance	11-15	Emissions Warranty	16-1
Every 1500 hours	11-15	Maintenance Chart	17-1
Checking injection and fuel pump	11-15		
Every 1 year	11-15		
Replacing air cleaner primary element and secondary element	11-15		
Every 2 years	11-15		
Changing brake fluid	11-15		
Flushing Cooling system and changing coolant	11-15		
Anti-freeze	11-16		
Replacing radiator hose (water pipes)	11-17		
Replacing fuel hose	11-17		



SAFE OPERATION

All operators, including experienced UTV drivers or passengers, should carefully read and fully understand this User's Manual, and operate strictly as the manual states in order to achieve best performance and avoid accidents. Others who will use this UTV should be trained how to operate the UTV and be required to read this manual before operation.

1. Safety Instructions:

1. Understand this UTV by reading this manual and understanding all the components of the vehicle. Only start and operate the vehicle after finishing reading this manual.
2. Pay close attention to the warning and caution labels on the UTV.
3. Understand completely and learn to use the safety devices (roll-over protective structure, seat belts), and never change original safety devices. If safety devices are damaged, consult your local dealer for replacement. Always use seat belts.

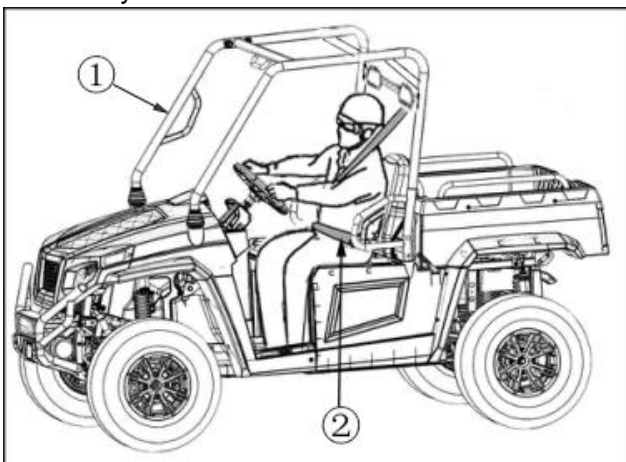

- ① Roll-over protective structure;
② Seat belts;

4. Do not wear loose articles of clothing during

operation, as these can be drawn into moving parts on the vehicle and could cause a severe injury to occur.

You should wear protective devices, such as helmet, boots, eye protection, ear protection, gloves, and etc.

5. Only a qualified driver should operate this UTV. Never operate after drinking, using drugs or controlled products, or while fatigued.
6. Always perform the pre-operation checks as following:
 - 1) Check seat belt for worn or damaged, if necessary, replace it.
 - 2) Check brakes, throttle, brake pedal and other mechanical parts for proper operation. If you discover any irregularities, replace related parts as necessary. Periodically check the fittings and fasteners.
 - 3) Check engine oil level and engine coolant level.
 - 4) Check that the UTV is equipped to handle the surroundings.
 - 5) Check and keep vehicle clean. Sludge, grease and debris can cause a fire and severe injury.
7. Passenger quantity and loading:
 - 1) Only the driver and one passenger inside cab. It is suggested that children under age of 5 not be allowed as a passenger.
8. Single-row vehicle's loading limit is 746lbs (330KG). Reduce loading weight according to road condition. Never exceed the weight limits for operation.
9. Never allow unauthorized persons to repair

this UTV. This may affect vehicle performance and cause injury.

10. This UTV is designed and manufactured for off-road use only, so never drive on paved roadways.

2. Operation

1. Start the engine only in an open ventilated area. Carbon monoxide is colorless, odorless and is emitted from the engine and can cause death in areas with poor ventilation.
2. Never start the vehicle or operate the gear selector unless seated in the driver's seat.
3. Never start engine before placing the gear shift lever in the "N" position.
4. The driver and passenger should always wear their seat belt while the vehicle is being operated.
5. Operators of the UTV should not wear earphones.
6. Use the trailer hitch to trailer cargo, otherwise, serious injury or death could occur.

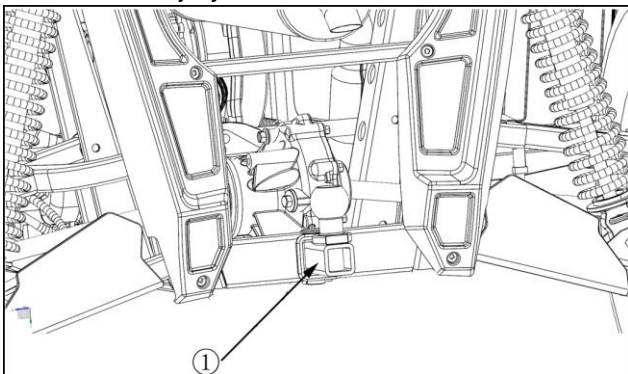

① Trailer Hitch

7. Do not accelerate quickly when starting, especially driving on rough terrain as this can cause injury or death. Press the accelerator pedal slowly and drive at slow speed before braking.
8. When the differential is locked (DIFF.LOCK is on) the front wheels cannot turn at different

speeds and the vehicle is less maneuverable

9. Never drive over terrain such as a ditch, a hole, dams, excessive mud, or the vehicle can get stuck because of the vehicles weight.
10. Always pay close attention to your surroundings, and check for streets, trail intersections or other obstacles.
11. Always use signals in advance of turns.
12. Do not allow entrance or exit of the vehicle while it is moving.
13. Clean dash board and keep the floorboard free of debris that can obstruct the ability to use the brake pedal.
14. Position your hands on the steering wheel. Always keep your hands and feet inside passenger area of the vehicle. Never try to stand while operating the vehicle.
15. Do not tow passengers, or attempt to jump the vehicle.

3. Children safety instructions

Always watch children when they are around the vehicle. Children like to imitate adults and this could lead to an accident.

Do not leave children alone beside the vehicle. Keep children from the operating area of the vehicle.

Turn off the engine and remove the key when children are in the operating area.

Never carry children in the cargo bed. This is very dangerous to children. Children under age of 5 are not allowed as passengers.

Never allow children to touch or climb the vehicle even if they are under adult supervision when climbing on vehicle.

Always check for people or obstacles behind the vehicle before shifting the vehicle into reverse to avoid a collision with an obstacle or person.

When parking the vehicle, park the on a firm, flat surface. If parking on a slope, you should use the parking brake, remove the key, and place a wedge under the tires.

4. Driving on a slope

Be cautious when riding on a slope, as this is the main reason for loss of control and overturn, leading to severe injury or even death.

1. Drive in a straight line on a slope at a low-speed.
2. Reduce weight when riding on a slope or rough terrain.
3. Avoid the sudden application of the brakes when you go uphill or downhill. Be more careful when turning on a slope.
4. If you start to lose momentum or need to park when climbing, use the parking brake to come to a stop. Release the brake and begin to coast down the hill slowly.
5. If do not believe you can operate the UTV safely in reverse do not attempt to ascend the slope any further.
6. Riding in mud, a ditch, and on slopes will increase the risk of an overturn. Be more cautious when operating. Drive gradually and slowly when climbing. Avoid sudden changes of vehicle speed or direction.
7. Drive gradually and slowly when climbing. Avoid sudden changes in vehicle speed or direction.

5. Driving in harsh conditions

1. Vehicle can be operated during the day or under good light conditions.
2. Operate the vehicle in open and smooth terrain.
3. Under all conditions, both operator and passengers should wear helmet and

protective equipment.

4. Driver should slow down according to road conditions, terrain, visibility conditions.
5. Be cautious when driving over a ditch, stone road or hidden obstacles.
6. Avoid operating in any unknown depth of water. (water depth should not exceed axle height)

6. Driving at high speed

1. Check for front/rear wheels conditions. Pay attention to the difference in braking performance between two and four-wheel drive settings.
2. Slow down when turning. Turning at high speeds may result in an accident which could cause injury or death.
3. Turn on your headlights at high speeds.
4. Drive only when the vehicle speed can be controlled.
5. Do not use DIFF.LOCK when driving at high speed. Otherwise, this may cause vehicle loss of control.
6. When driving at high speeds, suddenly turning the steering wheel will reduce vehicle stability. Never sharply turn the steering wheel at high speeds.

7. Instructions for Cargo Area

1. Never carry a passenger in the cargo area.
2. Evenly distribute the cargo to maintain proper stability. Avoid overloading the cargo area. Cargo should be securely attached.
3. Reduce loaded weight when driving on poor road conditions or steep inclines.
4. Do not put your hands or any part of your body under the cargo bed when it is raised. Once lowered, lock the cargo bed in place before operating the vehicle. Never drive

before securing and locking the cargo bed.

8. Parking

1. Set the gear shift to the “N” position and to release the parking brake, depress the brake pedal.
2. Avoid stopping the vehicle on a slope. If stopping on a slope make sure the vehicle is stationary before exiting

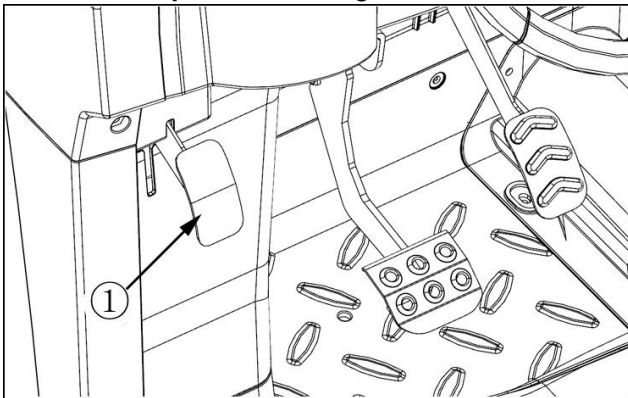

① Parking brake lever.

9. Transportation

1. Avoid dragging the vehicle behind another vehicle. Use a trailer or truck to transport the vehicle.
2. When loading or unloading, pay attention to your surroundings and others in the area.

10. Maintenance

Stop the vehicle and park it on level ground. Pull the parking brake and remove all cargo. Then place shift lever on “N” position, stop the engine and remove the key.

1. When working next to the engine, exhaust or radiator, work only after it has cooled down.
2. Wait for the engine to stop running and cool down before checking the coolant level. Otherwise, you could be burned by hot fluid

or steam blown out.

3. No smoking when adding electrolyte or refueling. Fuel tank and battery should be kept away from sparks. Battery produces hydrogen and oxygen during charging and this could accelerate the risk of explosion.
4. Read and follow the instructions before replacing the battery.
5. During maintenance, first aid kits and fire extinguishers should be placed at your fingertips.
6. During maintenance, you should disconnect the battery cables.

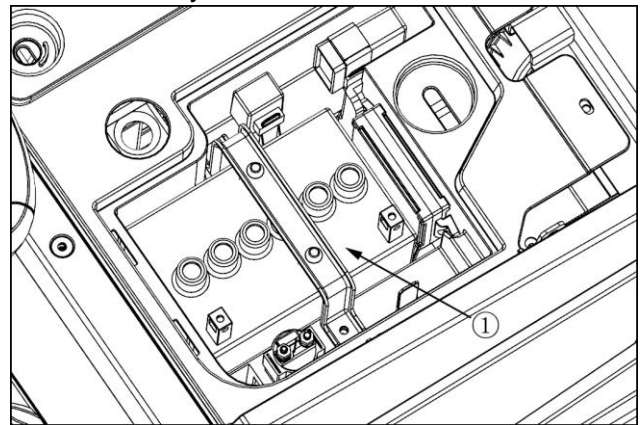

① Battery

7. Do not open radiator cap before coolant has cooled down. When the coolant is cold, open slowly and let the coolant pressure reduced, and then open water cooler cap. Check for the coolant level in the coolant reservoir. If necessary, add coolant.
8. Tires should be mounted on rims with special equipment by professionals.
9. Keeping specified tire pressure will help to ensure driving safety.
10. Elevate the vehicle and place a suitable stand under the frame when removing the wheels, be sure to tighten the wheel nuts to specified torque.

11. Warning and caution labels

<p>(1)</p> <div style="border: 1px solid black; padding: 5px;"> <p style="text-align: center;">⚠ WARNING</p> <ul style="list-style-type: none"> • Turn speed not to exceed 18 MPH/30 KPH • Do not drive in the water deeper than 400mm </div>	<p>(2)</p> <div style="border: 1px solid black; padding: 5px;"> <p style="text-align: center;">⚠ WARNING</p> <p>Operation takes more effort while the vehicle is in 4WD-LOCK.</p> <p>When in 4WD-LOCK operate at a slow speed and allow extra time and distance for turns to avoid loss of control.</p> </div>
--	---

<p>(3)</p>	<div style="border: 1px solid black; padding: 10px;"> <p>Chongqing Huansong Science And Technology Industrial Co.,Ltd</p> <p>This structure meets ROPS requirements for earth-moving machinery under ISO 3471.</p> </div>
------------	--

<p>(4)</p>	<div style="background-color: #f4a460; padding: 5px; border: 1px solid black;"> <p style="margin: 0;">⚠ WARNING:</p> </div> <div style="display: flex; align-items: center; margin-top: 5px;">  <div style="text-align: left;"> <p>EXHAUST FUMES MAY CAUSE HARM</p> <p>Engine exhaust from this product contains chemicals, known in certain quantities to cause cancer, birth defects, or other reproductive harm.</p> </div> </div>
------------	--

<p>(5)</p>	<div style="border: 1px solid black; padding: 5px;"> <p style="text-align: center;">⚠ WARNING</p> <p>Severe INJURY or DEATH can result if you ignore the following guidelines:</p> <ul style="list-style-type: none"> • Maximum load in cargo bed is 350lbs (159kg) • Never carry passengers in cargo bed. Passengers can be thrown off causing serious injury or death. • Cargo can affect handling and stability. Read Owner's Manual before loading or towing. • When operating with cargo or towing a trailer always reduce speed, allow more room to stop and avoid hills and rough terrain. • Be sure cargo is secured since a loose load can change vehicle handling. • Keep weight in the cargo bed centered and as low and far forward as possible. Top-heavy loads increase the risk of rollover. </div>
------------	---

(6)

⚠ WARNING

Improper Use of Off-Highway Vehicles Can Cause Severe Injury or Death

Be Prepared

- Fasten seat belts.
- Wear an approved helmet and protective gear.
- Each rider must be able to sit with back against seat, feet flat on floor [and foot rests], and hands on steering wheel or handhold[s], where equipped, Stay completely inside the vehicle.

Drive Responsibly
Avoid loss of control and rollovers:

- Avoid abrupt maneuvers, sideways sliding, skidding, or fishtailing, and never do donuts.
- Slow down before entering a turn.
- Avoid hard acceleration when turning, even from a stop.
- Plan for hills, rough terrain, ruts, and other changes in traction and terrain. Avoid paved surfaces.
- Avoid side hilling (riding across slopes).

Be Sure Riders Pay Attention and Plan Ahead

If you think or feel the vehicle may tip or roll, reduce your risk to injury:

- Keep a firm grip on the steering wheel or handholds and brace yourself.
- Do not put any part of your body outside of the vehicle for any reason.

Require Proper Use of Your Vehicle

Do your part to prevent injuries:

- Do not allow careless or reckless driving.
- Make sure operators are 16 or older with a valid driver's license.
- Do not let people drive or ride after using alcohol or drugs.
- Do not allow operation on public roads (unless designated for off-highway vehicle access)--collisions with cars and trucks can occur.
- Do not exceed seating capacity; 1 passenger.

[Locate and] Read [Owner's Manual]
Follow All Instruction and Warnings
[Reserved for Reference to Other Sources of Safety Information]



Rollovers have caused severe injuries and death, even on flat, open areas.



(7)

Chongqing Huansong Science And Technology Industrial Co.,Ltd certifies that this ROV complies with the American National Standard for Recreational Off-Highway Vehicles, ANSI/ROHVA 1 - 2011 Standard.

(8)

⚠ WARNING

- DO NOT USE GAS MIXED WITH ETHANOL!
- USE 100% GAS ONLY
- USE WITH ETHANOL MIXED GAS WILL CAUSE DAMAGE TO THE MACHINE AND WILL VOID YOUR WARRANTY
- Use NON-ETHANOL gasoline if possible. IF ETHANOL gasoline is not available then use 91 octane or higher gasoline.

(9)

⚠ WARNING

Never carry passengers in cargo bed.



(10)

- Max towing weight:544kg(1200lbs)
- Max tongue weight:50kg(110lbs)

<p>(11)</p> <div data-bbox="248 383 667 568" style="border: 1px solid black; padding: 5px;"> <p style="text-align: center;">⚠ WARNING</p> <p>Change the oil when the temperature drops to -15 Celsius (5° Fahrenheit)</p> </div>	<p>(12)</p> <div data-bbox="826 286 1437 667" style="border: 1px solid black; padding: 5px;"> <p style="text-align: center;">⚠ WARNING</p> <p>Improper tire pressure or overloading can cause loss of control. Loss of control can result in severe injury or death.</p> <ul style="list-style-type: none"> • Cold tire pressure: Front : 10psi (70kPa) Rear : 10psi (70kPa) • Maximum weight capacity:1898lbs.(861kg) </div>
--	--

<p>(13)</p> <div data-bbox="379 770 1209 1055" style="border: 1px solid black; padding: 10px;"> <p style="text-align: center;">⚠ WARNING</p> <div style="display: flex; align-items: center;">  <ul style="list-style-type: none"> • Keep hands and body safely away when closing bed.. • NEVER operate the vehicle with the bed up. </div> </div>

<p>(14)</p> <div data-bbox="288 1160 624 1518" style="border: 1px solid black; padding: 5px;"> <p style="text-align: center;">⚠ WARNING</p> <p>Improperly loading a trailer and failure to use extra care when pulling trailer can cause an accident or injury. Never load more than 110lbs (50kg) tongue weight on the towing bracket. Do not tow more than 1200lbs (544kg) rolling weight (trailer plus cargo). Operate in low-range gears only, allow for increased braking distance, and use extreme caution when operating on inclines. Read carefully the loading information and trailer hitch sections in the owner's manual.</p> </div>	<p>(15)</p> <div data-bbox="979 1249 1283 1435" style="border: 1px solid black; padding: 5px;"> <p style="text-align: center;">⚠ CAUTION</p> <p>Select gear "L" on rough terrain and sloped terrain.</p> </div>
---	--

SERVICING OF VEHICLE

Your dealer is interested in your new vehicle and has the desire to help you get the most value from it. After reading this manual thoroughly, you will find you can do some of the regular maintenance by yourself.

However, when in need of parts or major service, be sure to see your dealer.

For service, contact the dealership from which you purchased your vehicle or your local dealer.

When in need of parts, be prepared to give your dealer both the vehicle and engine serial numbers.

Locate the serial numbers now and record them in the space provided.

	Type	Serial No.
Vehicle		
Engine		
Product Identification Number		
Date of Purchase		
Name of Dealer		

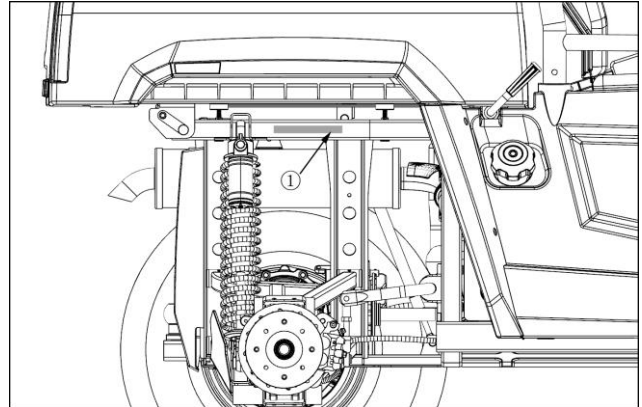

① Vehicle serial number.

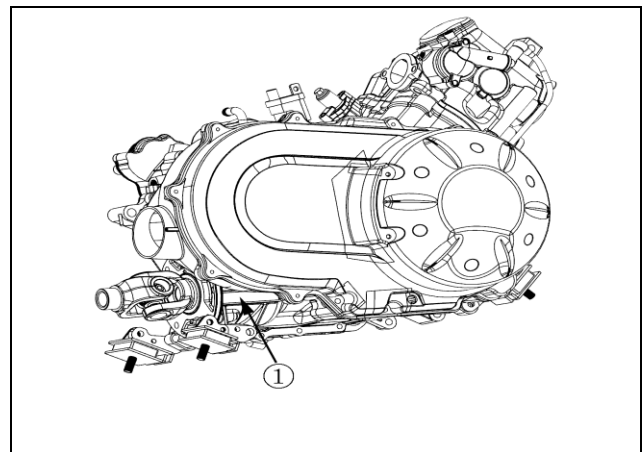

① Engine serial number

SPECIFICATIONS

SPECIFICATION TABLE

Model			Vector	500	
Engine	Make		H-L forward, Neutral, Reverse		
	Type		4-stroke, Water cooled		
	Displacement		471cm ³		
	Horsepower		Kw(HP)	16	
	Rated revolution		rpm	7000	
	Low idling revolution		rpm	1350 to 1500	
Fuel Capacity		L(U.S.gas)	29 (7.6)		
Transmission			CVT		
Wheels, Drive system			4, Rear 2WD or 4WD		
Differential lock			Electric control: switch		
Gear selection			L-H-N-R		
Brakes	Front/Rear		Hydraulic disk brake		
	Parking brake		Hydraulic disk brake		
Steering			Mechanical Steering		
Suspension	Front		Independent, dual A-Arm		
	Rear		Independent, dual A-Arm		
Dimensions	Length		mm(in.)	2880 (113.83)	
	Wide		mm (in.)	1760 (69.29)	
	Height		mm (in.)	1900 (74.8)	
	Front tread centers		mm (in.)	1350 (53.14)	
	Rear tread centers		mm (in.)	1300 (46.5)	
	Wheelbase		mm (in.)	1850 (51.18)	
	Ground Clearance	front axle	mm (in.)	310 (12.2)	
		rear axle		310 (12.2)	
Turning diameter		m (ft)	6.84 (22.44)		
Max. rolling weight (Towing Capacity)		kg (lbs.)	905 (1995)		
Cargo Payload capacity		kg (lbs.)	159 (350)		
Weight		kg (lbs.)	586 (1292)		

Model		Worksite/Orange	Worksite/Camo
Cargo bed	Width	mm (in.)	1305 (51.37)
	Length (row)	mm (in.)	775 (30.52)
	Depth	mm (in.)	285 (11.22)
	Volume (row)	m ³ (cu.ft.)	0.23 (8.11)
	Bed height (unloaded)	mm (in.)	927 (36.49)
	Cargo bed capacity	kg (lbs.)	159 (350)
Sound level, operator ear		db (A)	85
Tire	Front	26x9-12 6PR	26x9-12 6PR
	Rear	26x10-12 6PR	26x10-12 6PR
Body color		Dark Green	Camo

NOTE:

- The values in “Ground clearance” and “Weight” are those of the machine equipped with the tires in the table above.
- The company reserves the right to change the specifications without notice.

TRAVELING SPEEDS

Range gear shift lever	km/h (mph)
Front	65 (37)
Reverse	16 (10)

VEHICLE LIMITATIONS

The Vehicle has been thoroughly tested for proper performance with implements sold or approved by manufacturer. Use with implements which are not sold or approved and which exceed the maximum specifications listed below, or which are otherwise unfit for use, may result in vehicle malfunction or failures with a possibility of vehicle damage to other property and injury to the operator or others, any malfunctions or failures of the vehicle resulting from use with improper implements are not covered by the warranty.

Max. Cargo loading weigh	Rear trailer hitch
(a)1 ROW SEATING MODE Cargo Bed Capacity=150Kg(350 lb) Cargo Load Capacity=180kg(396 lb) *(operator+one passenger+opt+acc)weight	Max. rolling weight 590 kg (1300 lbs.)
	Max. tongue weight 50 kg (110 lbs.)

1. Above mentioned specifications are based on level ground condition.

INSTRUMENT PANEL AND CONTROLS

LOCATION OF PARTS

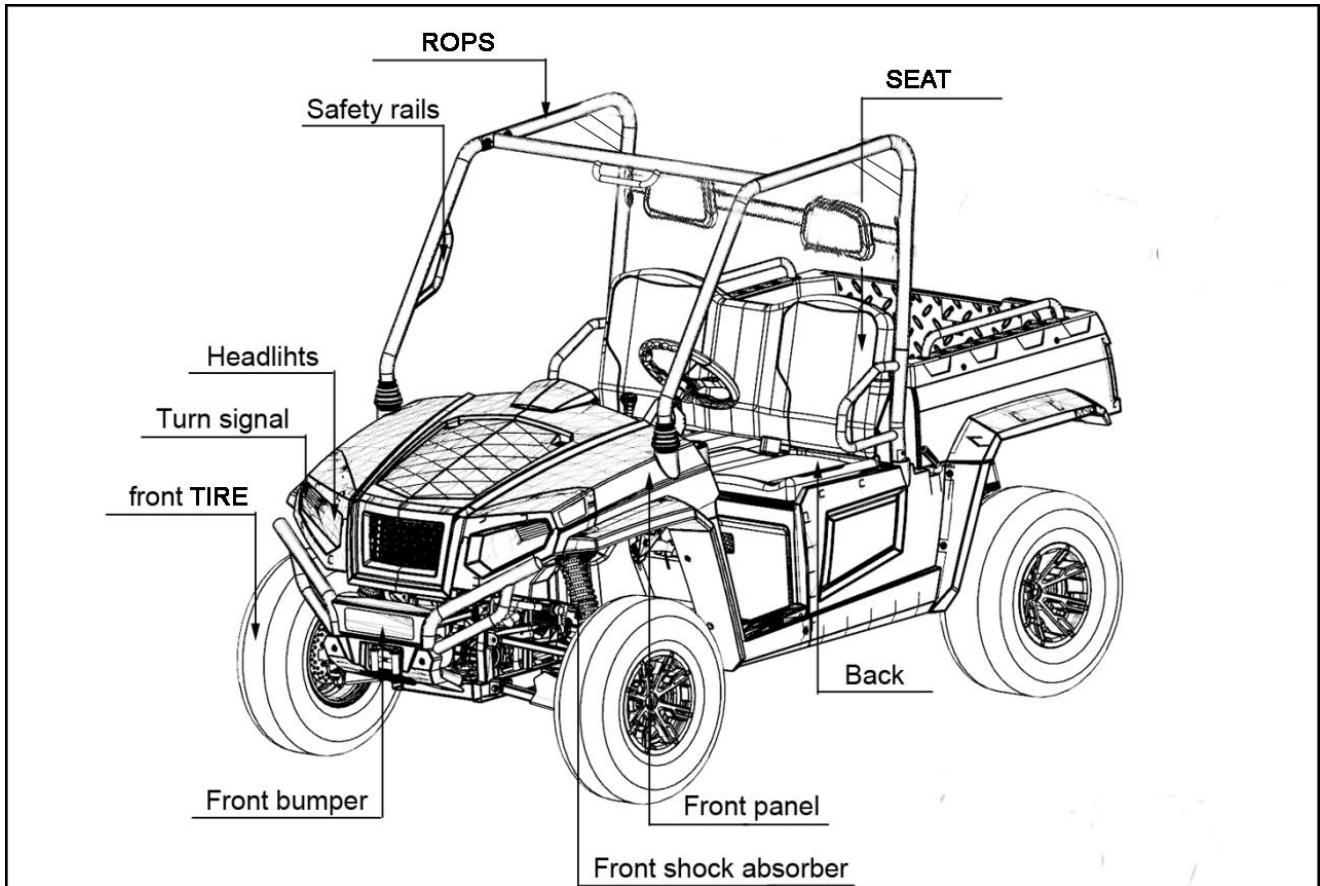

ILLUSTRATED CONTENTS

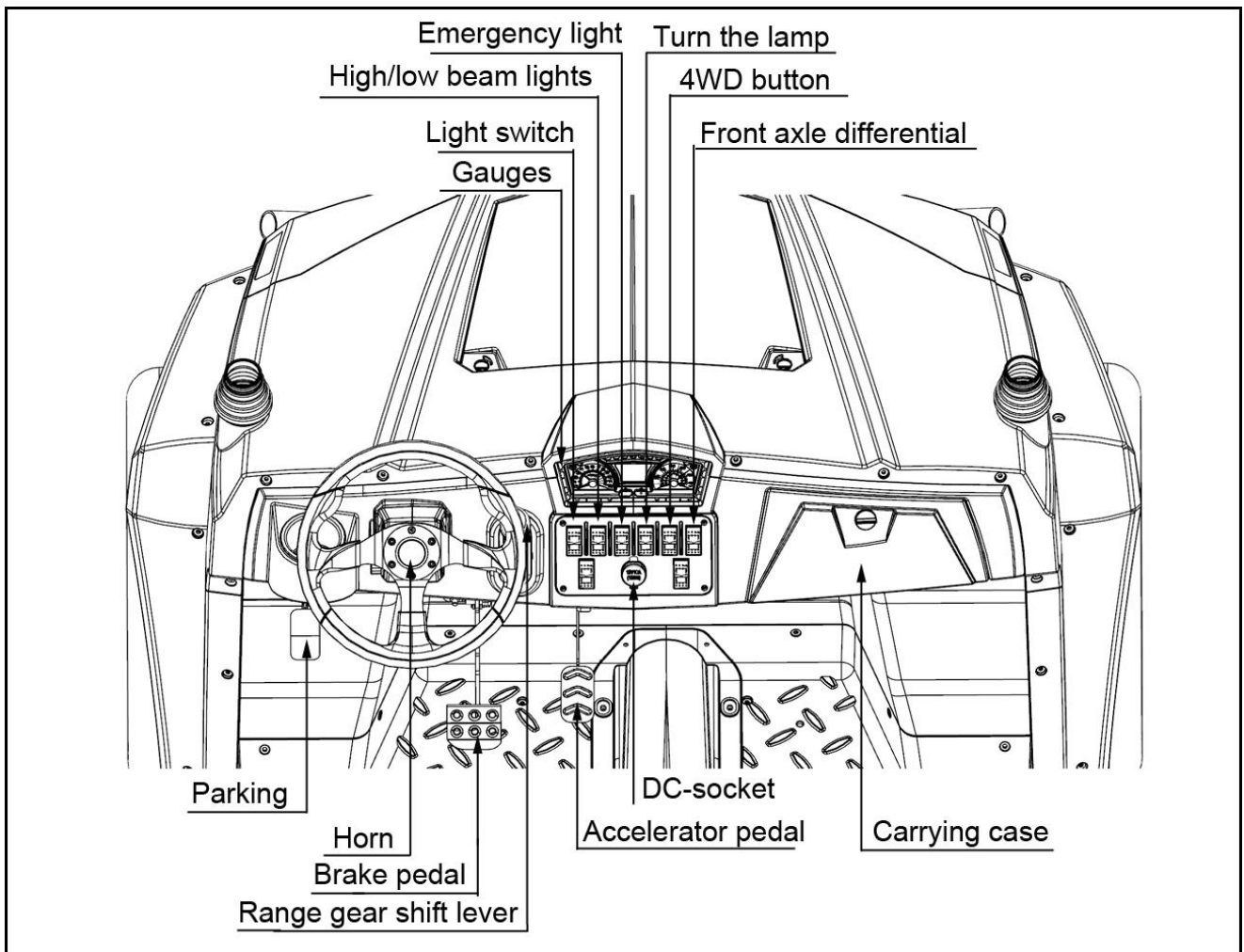

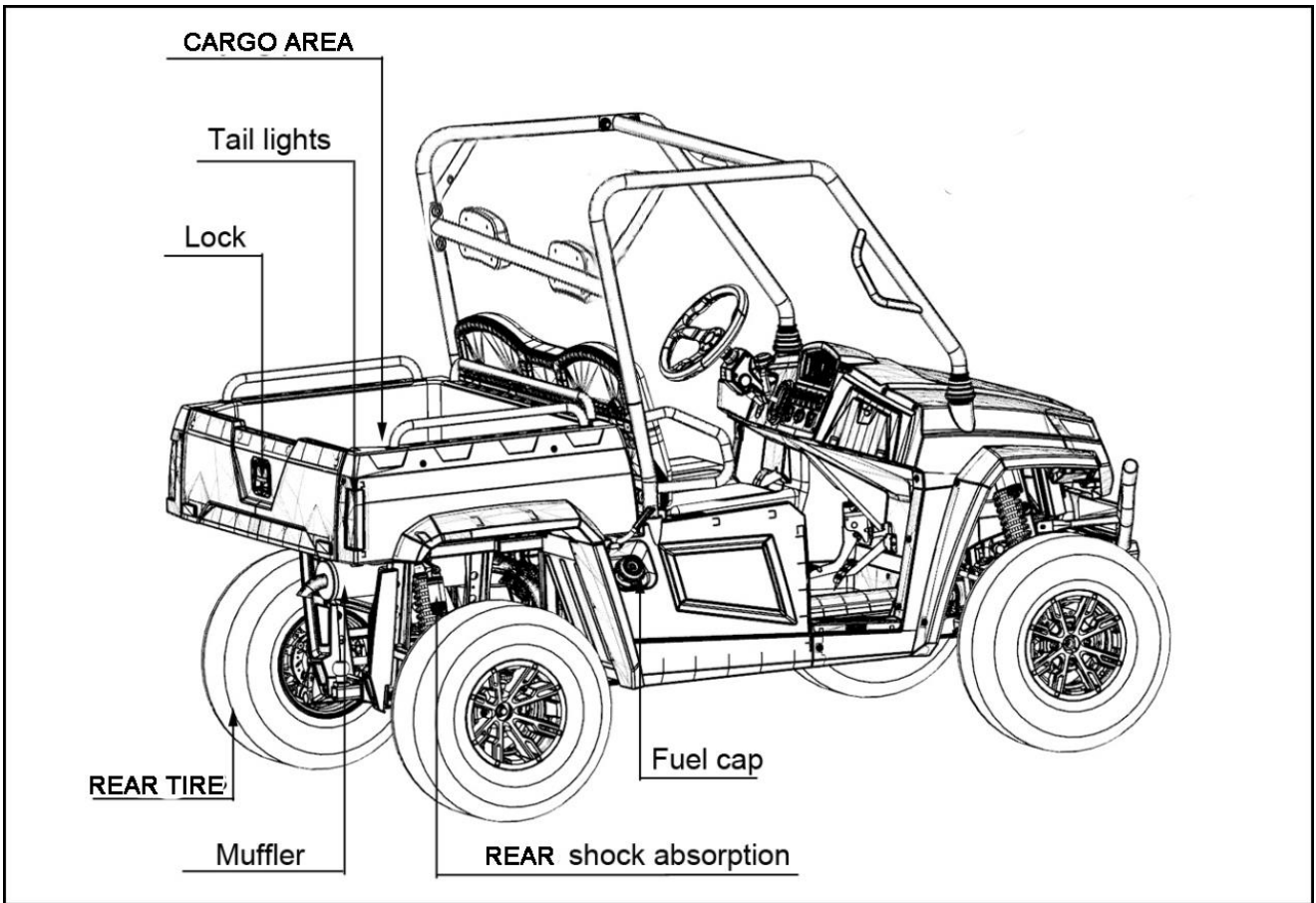

PRE-OPERATION CHECK

DAILY CHECK

To better prevent troubles, it is important to know condition of the vehicle well. Check it before starting.



CAUTION:

To avoid personal injury:

Be sure to check and service the vehicle on a level surface with the engine shut off and the parking brake "ON" and implement lowered to the ground if equipped.

Check items

- Walk around inspection
 - Check engine oil level
 - Check transmission oil level
 - Check brake fluid level
 - Check coolant level
 - Clean radiator screen
(When used in a dusty place)
 - Check brake and pedal
 - Check parking brake
 - Check indicators, gauges and meters
 - Check lights
 - Check seat belts and roll-over protective structures.
 - Check front and rear joint boots.
 - Check tire inflation pressure.
 - Check backup beeper (if equipped).
 - Refuel
- (See "DAILY CHECK" in "PERIODIC SERVICE" section.)
- Care of danger, warning and caution labels
- (See "DANGER, WARNING AND CAUTION LABELS " in " SAFE OPERATION " section.)

OPERATING THE ENGINE



CAUTION:

To avoid personal injury:

- Read "SAFE OPERATION" in front of this manual.
- Read the danger, warning and caution labels located on the vehicle.
- To avoid the danger of exhaust fume poisoning, do not operate the engine in closed buildings without proper ventilation.
- Start engine only from operator's seat. Never start engine while standing on ground.
- Make it a rule to set gear shift lever to "NEUTRAL" position before starting the engine.

IMPORTANT:

- Do not use starting fluid or ether.
- To protect the battery and the starter, make sure that the starter is not continuously turned for more than 10 seconds.

STARTING THE ENGINE

1. Make sure the parking brake is set.

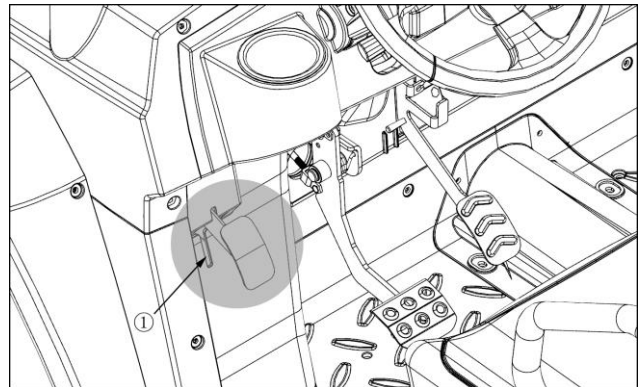

① Parking brake lever

NOTE:

The parking brake warning lamp (P) comes on while parking brake is applied and goes off when it is released.

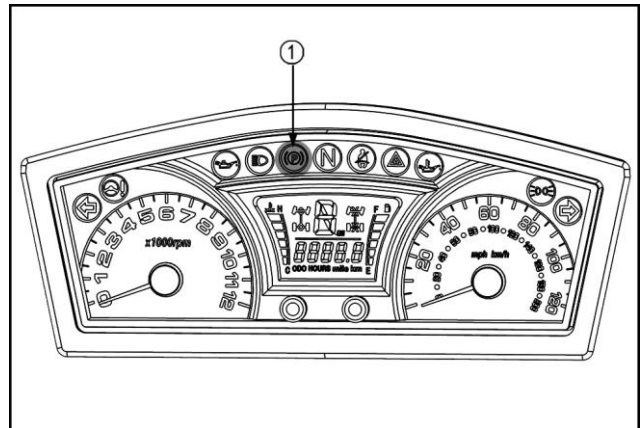

① Parking brake warning lamp

2. Set gear shift lever to the “NEUTRAL” position.

- ① Range gear shift lever.
- (H) High Range
- (L) Low Range
- (N) “Neutral” position
- (R) “REVERSE”

3. Push the speed accelerator pedal down about 1/2 way.

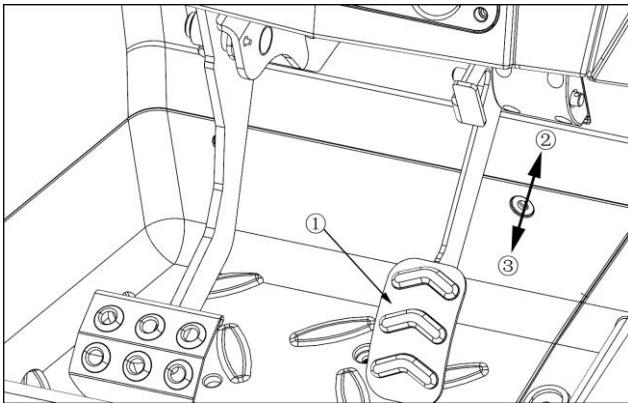

- ① Speed control pedal
- ② “INCREASE
- ③ “DECREASE

4. Push the accelerator pedal down about 1/2 way.

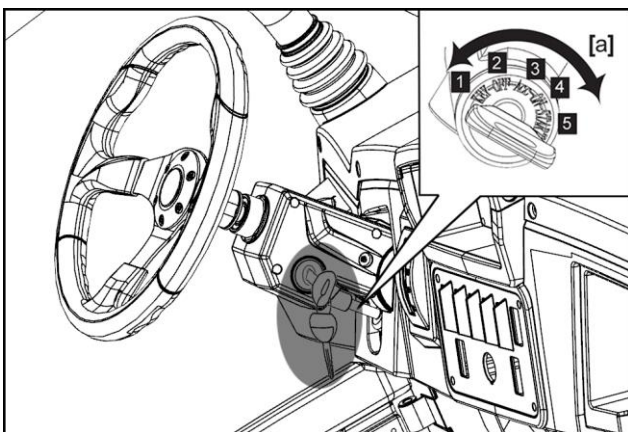

1. Insert the key into the key switch and turn it “START”.

- OFF (Engines stop)
- ON (Engine run or headlight on)
- START (Engine start)

◆ **Checking the indicator / warning lights:**

1. When the key is turned “START”, lamps (1 engine oil pressure) should come on. If trouble occurs at any location with engine running, the warning lamp corresponding to that location comes on.
2. The parking brake warning lamp (2 parking brake) comes on while parking brake is applied and goes off when it is released.

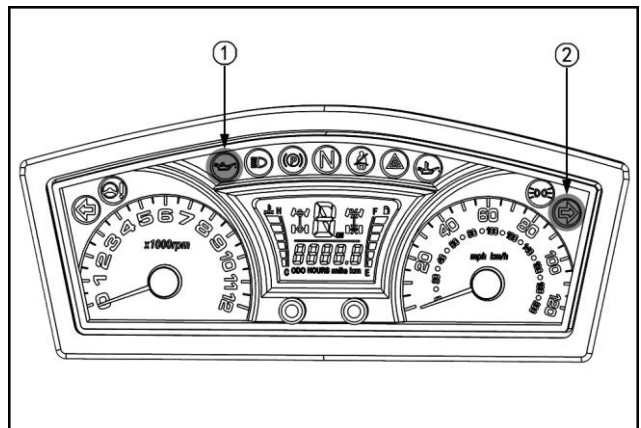

IMPORTANT :

- Daily checks with the indicator/warning lights only, are not sufficient. Never fail to conduct daily checks carefully by referring to “DAILY CHECK” in “PERIODIC SERVICE” section.

5. Turn the key to “START” position and release when the engine starts.

IMPORTANT:

- Because of safety devices, the engine will not start except when the gear shift lever is placed in the “NEUTRAL” position.

■ **Cold Starting**

When the ambient temperature is below -15°C (5°F), the engine is very cold. If the engine fails to start after 10 seconds, turn off the key for 30 seconds and start again.

STOPPING THE ENGINE

1. After slowing the engine to idle, turn the key to "OFF".
2. Remove the key.

WARMING UP



CAUTION:

To avoid personal injury:

- Be sure to set the parking brake during warm-up.
- Be sure to set the shift lever to the "NEUTRAL" position during warm-up.

For 5 minutes after engine start-up, allow the engine to warm up without applying any load. This is to allow oil to reach every engine part. If load applied to the engine without warm-up, troubles such as seizure, breakage or premature wear may occur.

■ Warm-Up Transmission Oil in the Low Temperature Range

IMPORTANT:

- Do not operate the vehicle under full load condition until it is sufficiently warmed up.

OPERATING THE VEHICLE

OPERATING NEW VEHICLE

How a new vehicle is handled and maintained determines the life of vehicle.

A new vehicle just off the factory production line has been, of course, tested, but the various parts are not aligned to each other, so the operator should pay more attention to operating the vehicle for the first 50 hours at a slower speed and avoid excessive work or operation until the various parts become “broken-in.” The manner to which you handle the vehicle during the “breaking-in” period greatly affects the life of your vehicle. Therefore, to obtain the maximum performance and the longest life of the vehicle, it is very important to properly break-in your vehicle. For better handling a new vehicle, the following precautions should be observed.

■ Do not operate the vehicle at full speed for the first 50 hours.

- Do not start quickly nor apply the brakes suddenly.
- In winter, operate the vehicle after fully warming up the engine.
- Do not run the engine at speeds faster than prescribed.
- On rough roads, slow down to suitable speeds.

Do not operate the vehicle at fast speed. The above precautions are not limited to new vehicles, but to all vehicles. It should be especially observed for new vehicles.

■ Changing Lubricating Oil for New Vehicles

The lubricating oil is especially important for a new vehicle. Various parts are not “broken-in” and are not aligned to each other. Small pieces of metal grit may develop during the operation of the vehicle; and this may wear out or damage the parts. Therefore, take care to change the lubricating oil a little earlier than would ordinarily be required. For further details of change interval hours, see “MAINTENANCE” section.

STARTING

1. Fasten the seat belt.

■ Seat Belt



To avoid personal injury:

- **Seat belts reduce injury. Always wear your seat belts. The lap-style seat belts may not provide adequate protection for small children. Pay special attention when carrying a child passenger as a passenger.**

**CAUTION:**

To avoid personal injury:

- Always use the seat belts when operating and riding the vehicle.

Adjust the seat belts for proper fit and connect the buckle. This seat belt is an auto-locking retractable type.

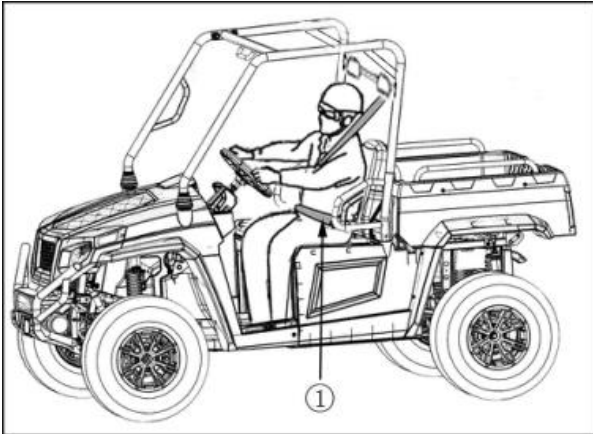

① Seat belt

2. Selecting light switch position.**■ Head Light Switch**

Turn on the key switch and turn the head light switch to the “ON” position.

Turn the head light switch to the “OFF” position to turn off the head light.

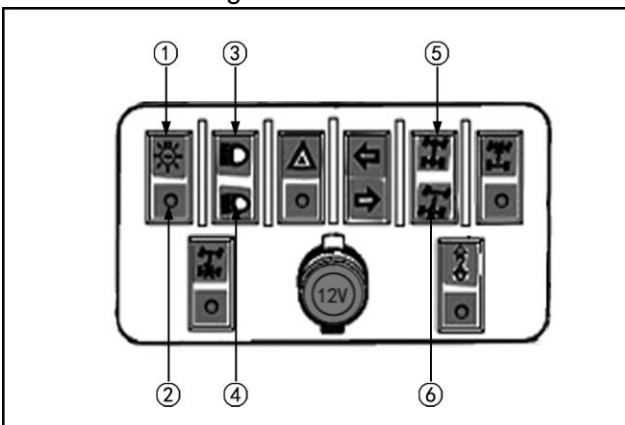

- ① Head light switch
- ② Head lights “OFF”
- ③ Dipped headlight “ON”;
- ④ Headlights on full beam “ON”;
- ⑤ 4WD button
- ⑥ 2WD button

NOTE:

Turning the head light switch to the “ON” position causes the following lamps to light simultaneously.

1. Tail lights (lamps at the rear portions of the vehicle)
2. Lamp built in the coolant temperature gauge
3. Lamp built in the fuel gauge
4. Lamp built in the speedometer

■ Hazard Light Switch

[if equipped]

Press the top half of the hazard light switch, the hazard light flash along with the indicator on the instrument panel. Press the bottom half of the hazard light switch to turn off the hazard light.

Note:

- The hazard light switch is operative when the key switch is in the “ON” or “OFF” position. Be careful that keeping the switch “ON” causes the battery to run out.

■ Turn Signal Light Switch

[if equipped]

To indicate a right turn, turn the turn signal light switch clockwise.

To indicate a left turn, turn the turn signal light switch using the arrow point to left. Use the right facing arrow for indicating right turns

When the left or right signal is activated, the indicated turning light will flash and the other will stay on.

The indicator lamp at the instrument panel also flashes like the above.

NOTE:

- The turn signal light switch is only operative when the key switch is in the “ON” position.

If the hazard light switch is pressed to the “ON” position while the turn signal is activated, the indicated turning light will flash and other will stay on.

- Be sure to return switch to center position after turning.

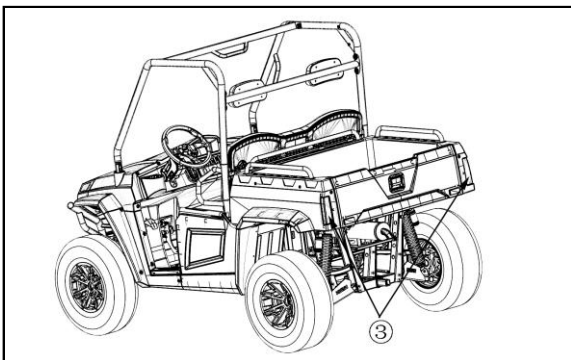
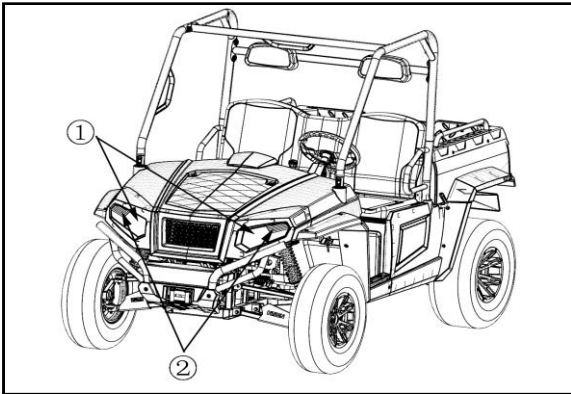

- ① Head light ② Head turn signal lamp;
- ③ Tail turn signal lamp

3. Checking the brake pedal.

■ Brake Pedal

CAUTION:

To avoid personal injury:

- If the operator suddenly brakes, an accident may occur due to loss of control or shifting forward of heavy loads.
- When driving on icy, wet or loose surface, make sure the vehicle is correctly balanced to avoid skidding or loss of steering control. Reduce the speed.

The brake pedal is the left pedal on the foot board. Depress the pedal to slow or stop the vehicle.

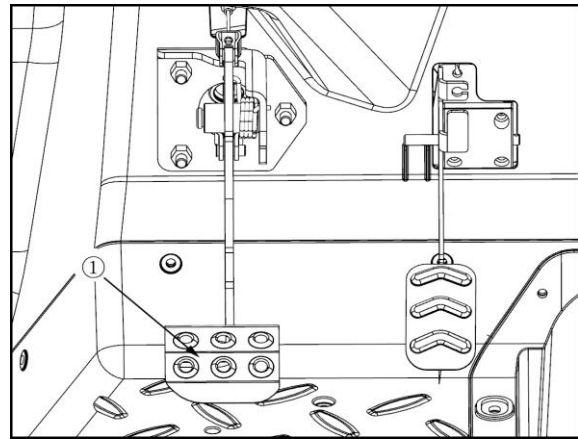

- ① Brake pedal

4. Selecting the travel speed.

■ Gear Shift Lever

CAUTION:

To avoid personal injury:

- Avoid changing gear shift lever when ascending or descending a slope.
- Before ascending or descending a slope, shift to the “L” position to control the vehicle speed.
- If you shift gears while ascending or descending a slope, be prepared to use the brake to maintain control.
- Operate in reverse at slow speeds to maintain control.

1. The gear shift lever can be shifted only when vehicle is completely stopped and the speed control pedal is in the “NEUTRAL” position.
2. To avoid transmission and shift linkage damage, completely stop the vehicle using the brake pedal before shifting gears.
3. Select proper gear and engine speed depending on the type of job.
4. Before dismounting vehicle, shift the gear shift lever to the “NEUTRAL” position and set parking brake.

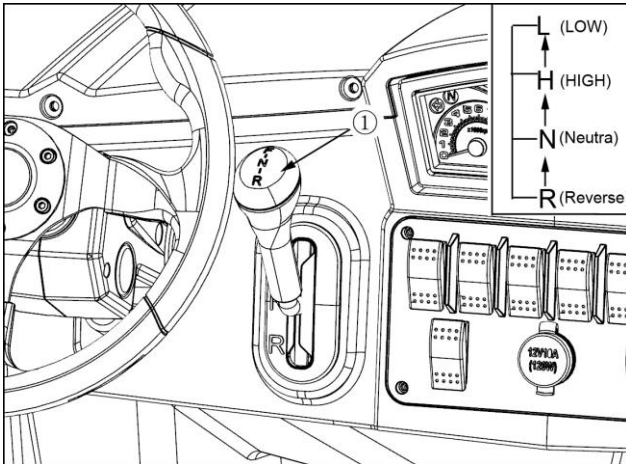

- ① Gear shift lever
- (L) LOW Range
- (H) HIGH Range
- (N) NEUTRAL POSITION
- (R) "REVERSE"

NOTE:

- When the gear shift lever is hard to engage, do not force the lever. Set the parking brake, slightly depress the speed control pedal and release it to neutral position, then shift the lever.
When the lever is hard to disengage, do not force the lever.
Depress the brake pedal fully, then shift the lever.
- An accident may occur if the incorrect shifting method is used.
- An improper gear shift lever position could cause damage to the transmission.

■ 4WD Lever

CAUTION:

To avoid personal injury:

- When traveling at road speed. Use only 2WD.
- When driving on icy, wet or loose surfaces, make sure the vehicle is correctly balanced to avoid skidding and loss of steering control. Reduce the speed and engage front wheel drive.

- Accident may occur if the vehicle is suddenly stopped, as heavy towed loads could shift forward causing loss of control.
- The braking characteristics are different between two and four wheel drive. Be aware of the differences and use caution.

IMPORTANT:

5. Unlock the parking brake and start slowly.

To release the parking brake, depress the brake pedal or push the release button and push down parking brake lever. Make sure that indicator light indicating the parking brake goes off.

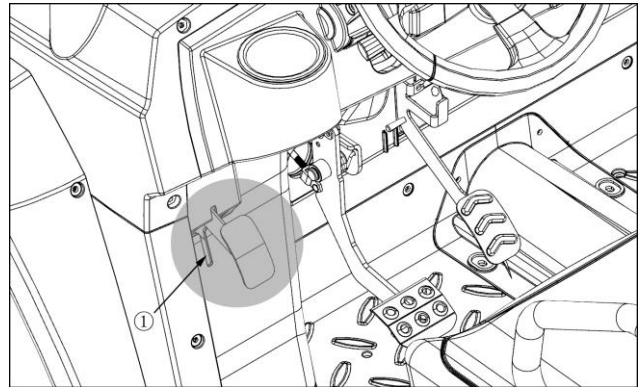

① Parking brake lever

■ Speed Control Pedal

Use the speed control pedal when traveling. Push down on it for higher speeds.

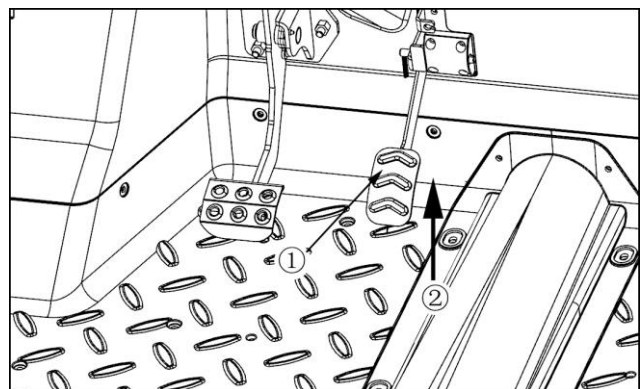

① Speed control pedal

STOPPING

■ STOPPING

1. Release the speed control pedal
2. Step on the brake pedal.

CHECK DURING DRIVING

■ Immediately Stop the Engine if:

- The engine suddenly slows down or accelerates.
- Unusual noises are suddenly heard.
- Exhaust fumes suddenly become very white.

While driving, check the following items to see if all parts are functioning normally.

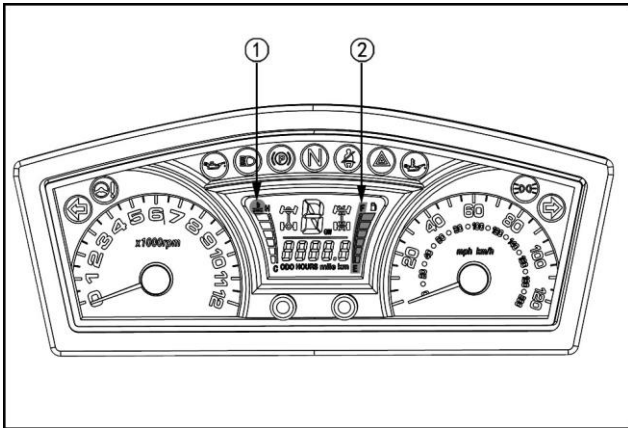

- ① Coolant temperature gauge
- ② Fuel gauge

■ Fuel Gauge

Park the vehicle on a flat place.

When the key switch is in the “START” position the fuel gauge indicates the fuel level.

Be careful not to empty the fuel tank. Otherwise air may enter the fuel system.

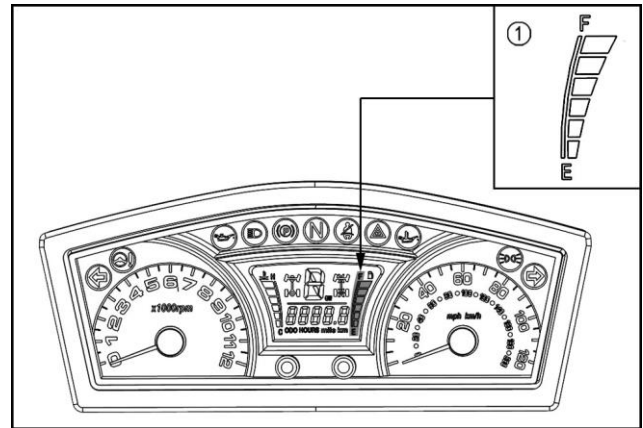

- ① Fuel gauge

■ Coolant Temperature Gauge

⚠ CAUTION:

To avoid personal injury:

- Do not remove radiator cap until coolant temperature is well below its boiling point. Then loosen the cap slightly to relieve pressure before removing cap completely.
1. With the key switch “ON” the temperature gauge indicates the temperature of the coolant. White Zone for “cold” and Red zone for “hot”.
 2. If the indicator reaches the Red zone, engine coolant is overheated. Check the vehicle by referring to “TROUBLESHOOTING” section.

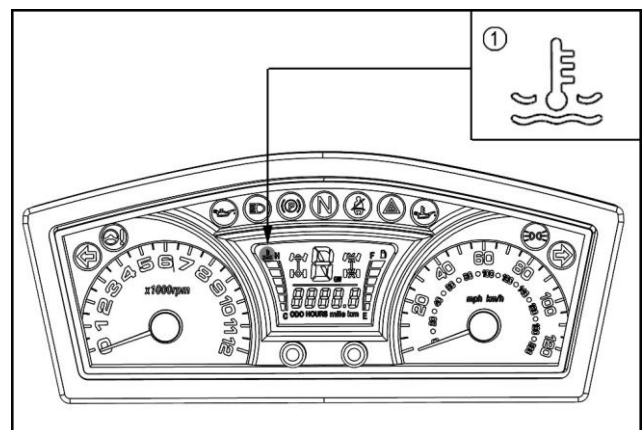

- ① Coolant temperature gauge

The hour meter indicates in five digits the hours the vehicle has been used; the last digit indicates 1/10 of an hour.

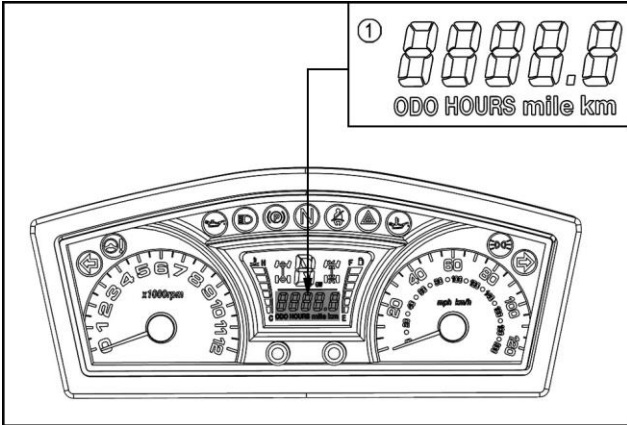

① Hourmeter

The speedometer indicates the traveling speed.

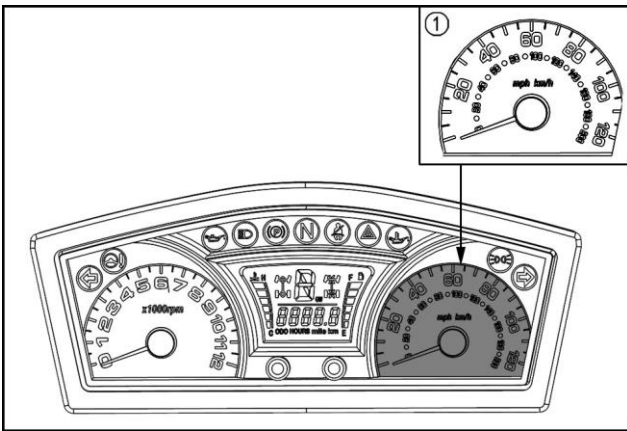

① Speedometer

WINCH MOUNT PLATE

WINCH MOUNT PLATE

Mounting the optional winch always requires reading the instruction manual included with the winch.

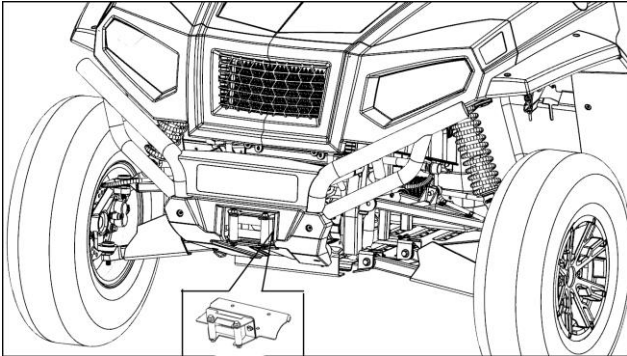

① Winch mount plate

■ Transporting Vehicle

Pay attention to the following points when transporting the vehicle.

1. Use a suitable truck or trailer.
2. Apply the parking brake and place chocks against the front and rear tires.

NOTE:

◆Engine Oil: (15W/40SL)

Oil used in the engine should have an American Petroleum Institute (API) service classification and Proper SAE Engine Oil according to the ambient temperatures as shown above.

◆Brake fluid:

Always use DOT3 GENUINE BRAKE FLUID from a sealed container.

PERIODIC SERVICE



CAUTION:

To avoid personal injury:

■ HOW TO OPEN THE HOOD COVER Cover AND TILT THE SEAT



CAUTION

To avoid personal injury from contact with moving parts:

- Never open operator's seat while the engine is running.
- Support hood with the other hand while unlocking support link.

■ Hood Box Cover To Open/ Close

Unhook the hood latches, and then slowly tilt the cover up. To close, tilt cover back to closed position and fasten the latches.

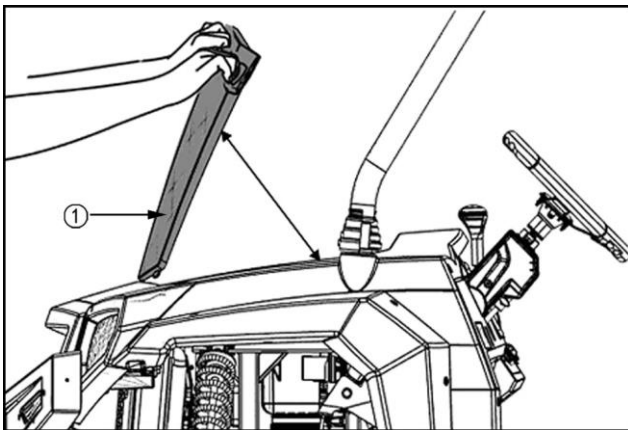

① Hood box cover

■ Operator's Seat

To open the seat, raise the seat to the forward position.

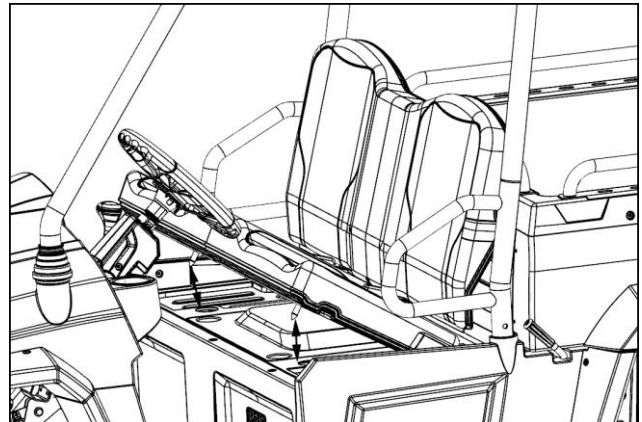

① Operator's seat

HOW TO RAISE THE CARGO BED



CAUTION

To avoid personal injury:

- When servicing under raised bed, make sure safety support is properly mounted.
- Do not touch muffler or exhaust pipes while they are hot; severe burns could result.

■ Raising and Lowering the Cargo Bed

◆ To raise the cargo bed

1. Apply the parking brake and start the engine.
2. Release the restricting plate.
3. Pull up the hydraulic lift cylinder lever to raise the cargo bed.
4. When the cargo bed has been raised, return the lever to the "NEUTRAL" position.
5. Stop the engine.
6. Mount the safety support.

◆ To lower the cargo bed

1. Start the engine and then lift the bed slightly by operating the lever.
2. Remove the safety support and store it in the given location.

3. Lower the lever to the "DOWN" position to lower the bed.
4. After making sure that the bed has lowered to the lowest position, lock it by the restricting plate.

NOTE:

Pull up the cargo bed handle to raise the cargo bed with the gas spring resistance

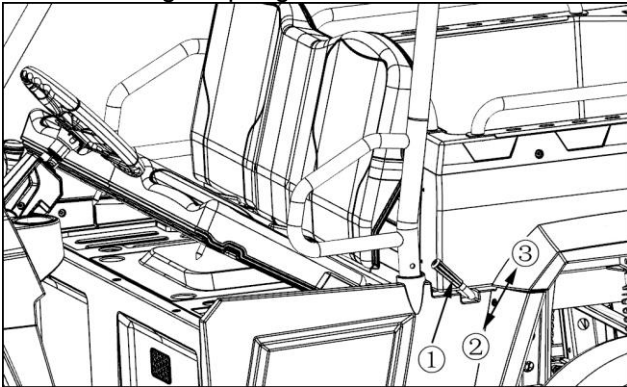

- ① Cargo bed release handle
- ② UP
- ③ DOWN

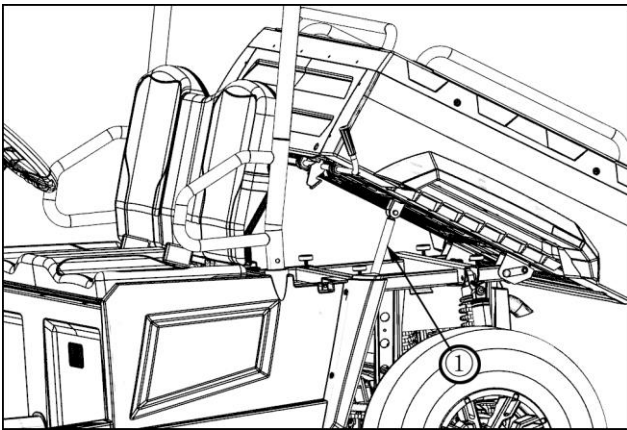

- ① Hydraulic cargo piston

JACK POINT

⚠ WARNING

To avoid personal injury, death or vehicle damage:

- Do not work under the vehicle unless it is secured by safe stands or suitable blocking.

■ Front End

Jack up at the front bumper only.

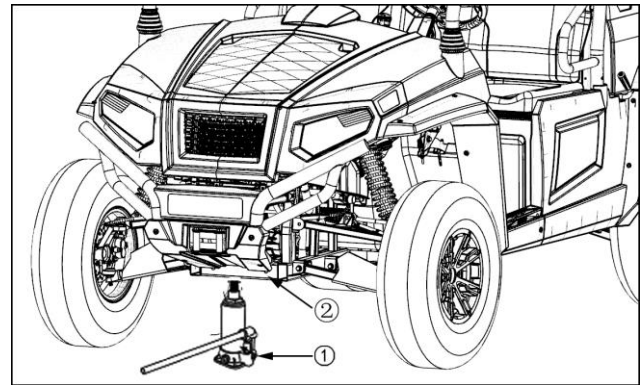

- ① Jack
- ② Front frame support

■ Rear End

Jack up the rear after placing a wooden block under the right and left vehicle frame for securing vehicle.

Do not jack up the vehicle directly under the engine.

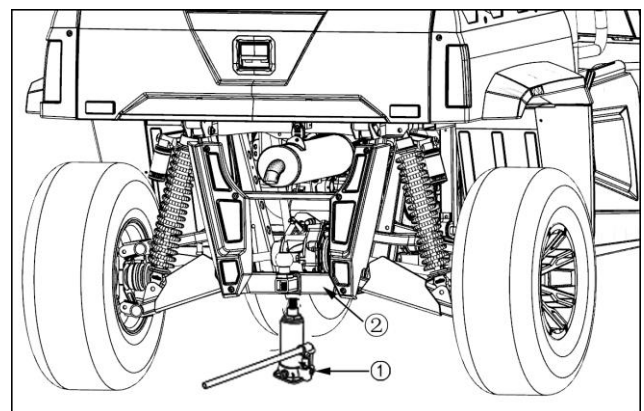

- ① Jack
- ② Rear Frame support

DAILY CHECK

For your own safety and maximum service life of the vehicle, make a thorough daily inspection before operating the vehicle or starting the engine.



CAUTION

To avoid personal injury:

- Be sure to check and service the vehicle on a flat surface with the engine off and the parking brake “ON”.

■ Walk Around Inspection

Look around and under the vehicle for such items as loose bolts, trash build-up, oil or coolant leaks, broken or worn parts

■ Checking and Refueling



CAUTION

To avoid personal injury:

- Do not smoke while refueling.
 - Be sure to stop the engine before refueling.
1. Turn the key switch to “ON”, check the amount of fuel by fuel gauge
 2. Fill fuel tank when fuel gauge shows 1/4 or less fuel in tank.

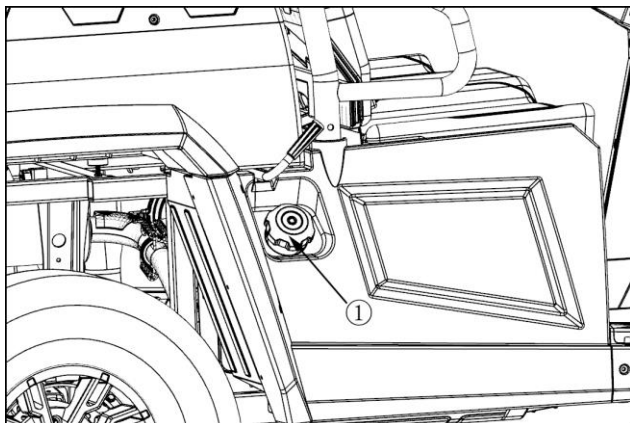

① Fuel tank cap

Fuel tank capacity	29L (7.6 U.S.GALS.)
--------------------	---------------------

IMPORTANT

If oil level is low, do not run engine.

Checking engine oil level

1. Park the vehicle on a flat surface, raise the cargo bed, mount the safety support and shut off engine.
2. To check the oil level, unscrew and remove the dipstick, wipe it clean, replace it, and draw it out again, check to see if the level is too low, add new oil to the prescribed level at the oil inlet.

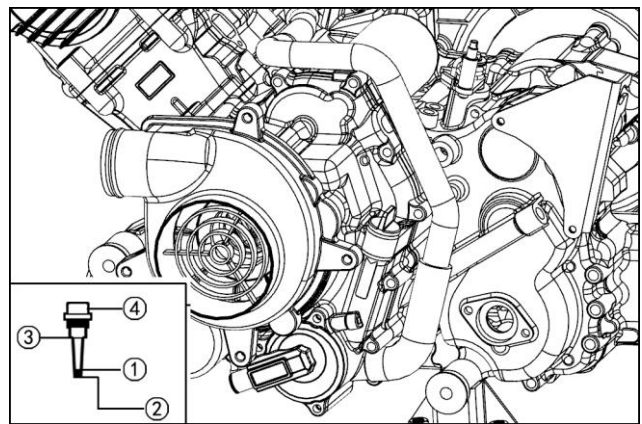

- ① Oil Level
- ② Oil inlet
- ③ Dipstick
- ④ Cap

IMPOTTANT

If oil level is low, do not run engine

■ Checking Coolant Level



CAUTION

TO avoid personal injury

- Do not remove radiator cap while coolant is hot. When cool, slowly rotate to the first stop and allow sufficient time for excess pressure to escape before removing the cap completely.

1. Park the vehicle on a flat surface, raise the cargo bed .mount, the safety support and shut off the engine.

2. Check to see that the coolant level is between the “FULL” and” LOW” marks of recovery tank.
3. When the coolant level drops due to evaporation, add water only up to the full level. In case of leakage add anti-freeze and water in the specified mixing ratio up to the full level.(see flush cooling system and changing coolant in EVERY 2 YEARS in PERIODIC SERVICE section)

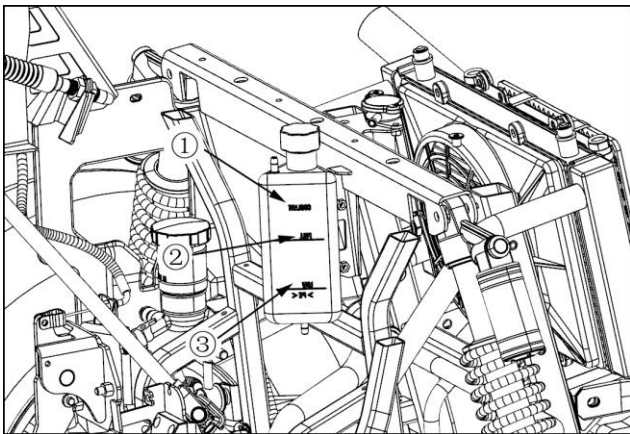

- ① Recovery tank
- ② FULL
- ③ LOW

IMPORTANT

- If the radiator cap has to be removed, follow the cautions above and securely retighten the cap.
- Use clean fresh water and anti-freeze to fill the recovery tank.
- If water should leak, consult your local HSUN Dealer.

■ **Cleaning radiator screen**



CAUTION

TO avoid personal injury:

- **Be sure to stop the engine before removing the screen**
1. Park the vehicle on a flat surface,
 2. Remove the radiator cover,
 3. Detach the screen and remove all foreign materials,

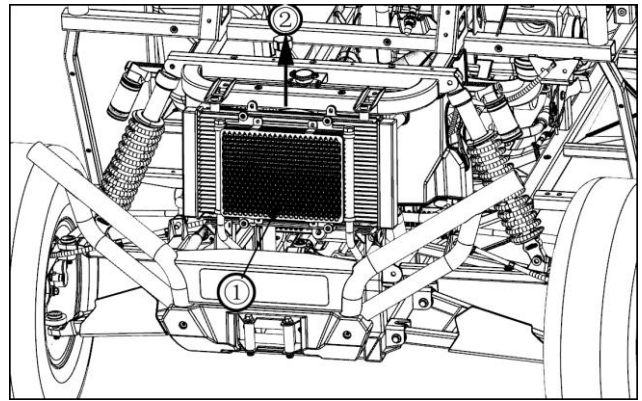

- ① Radiator screen

IMPORTANT

- Radiator screen must be clean from debris to prevent engine from overheating

■ **Checking brake fluid level**



CAUTION

TO avoid personal injury:

- **Never operate the vehicle if the brake fluid is below the minimum mark.**
 - **Use only DOT3 from a sealed container. Other type of oil may ruin synthetic resin or rubber installed in brake system components and may cause brake failure.**
 - **Avoid clean contamination of the brake fluid thoroughly before removing the filler cap. Do not open the brake fluid reservoir cap unless absolutely necessary.**
 - **Use extreme care when filling the reservoir. If brake fluid spills on the power steering hose, wash off with water immediately, as brake fluid quickly ruins synthetic resin or rubber hoses.**
1. Park the vehicle on a level ground and open the hood.
 2. Check to see that the brake fluid level is the LOWER mark.
 3. If it is below the “LOWER” mark add brake fluid .

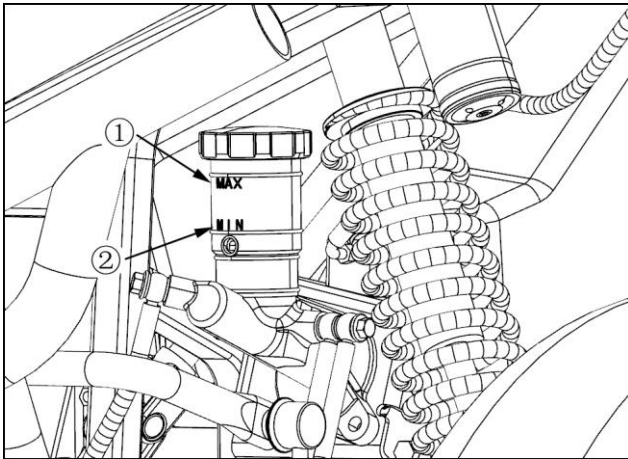

① OIL CUP ② LOWER

■ **Checking brake pedal**



CAUTION

TO avoid personal injury:

- **Stop the engine and chock the wheels before checking brake pedal.**

1. Inspect the brake pedals for free clearance and smooth operation.

Adjust if incorrect measurement is found. (see checking brake pedal in "EVERY 200 HOURS in PERIODIC SERVICE" section)

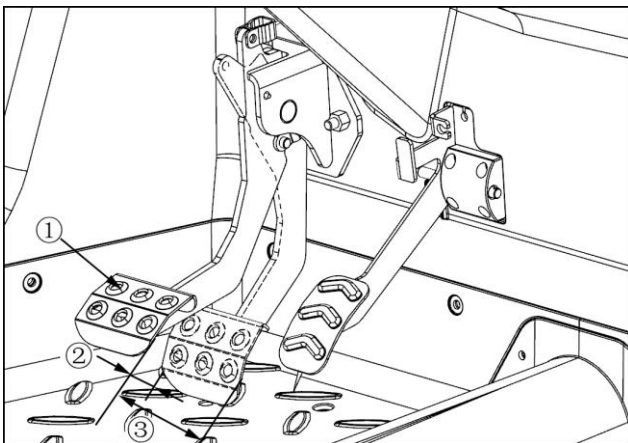

① Brake pedal ② FREE TRAVEL
③ PEDAL STROKE

■ **Checking parking brake**

Depress the parking brake to apply the brakes with the key switch in the "ON" position and the parking brake indicator should come on.

Make sure the parking brake warning lamp goes off when parking brake lever is down.

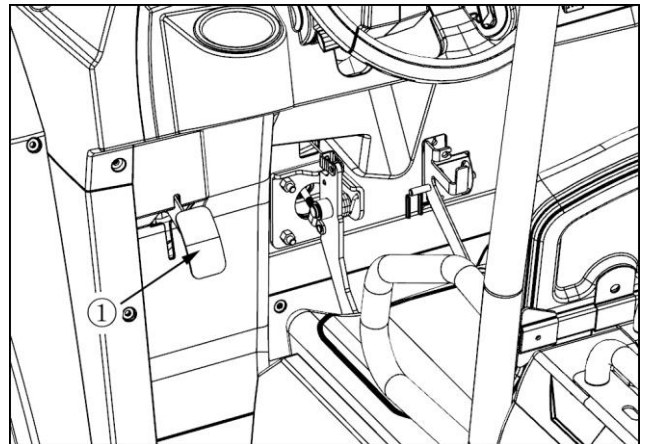

① Parking brake pedal

■ **Checking the warning lights and indicator lights.**

1. Inspect the instrument panel for broken warning light or indicator lights.
2. Replace if broken.

■ **Checking head lights turn signal lights**

1. Inspect lights for broken bulbs and lenses
2. Replace if broken

■ **Checking seat belt and ROPS**

1. Always check condition of seat belt and ROPS attaching hardware before operating vehicle.
2. Replace if damaged.

■ **Checking joint boot**

1. Check to see if the joint boots are damaged or not.
2. If the boots are cut or show signs of deterioration consult your local dealer.

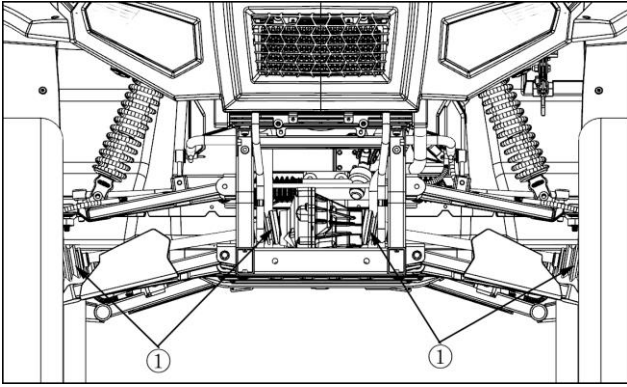

① joint boot ② Drive shaft

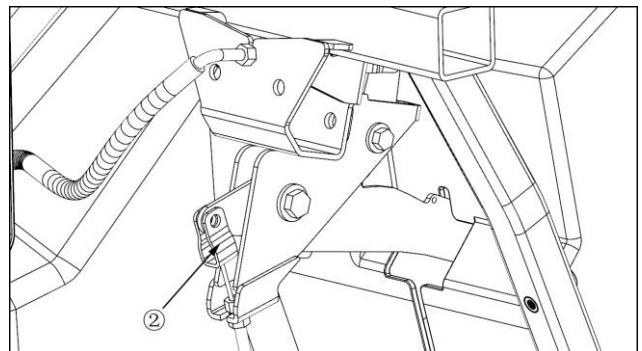
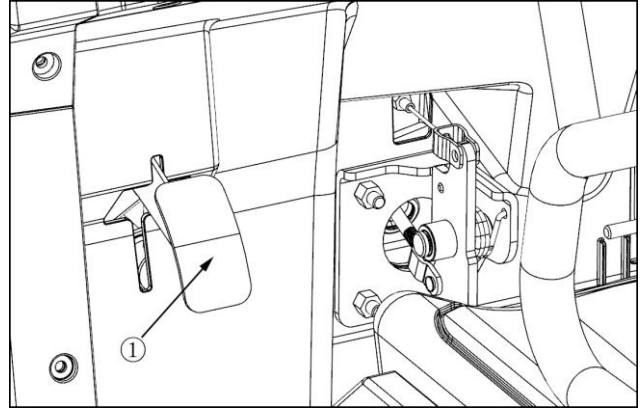

① Parking brake pedal
② Parking brake pivot(spray type grease)

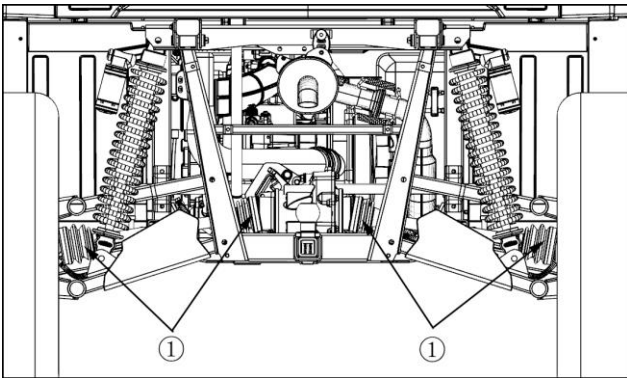

① Joint boot ② Drive shaft

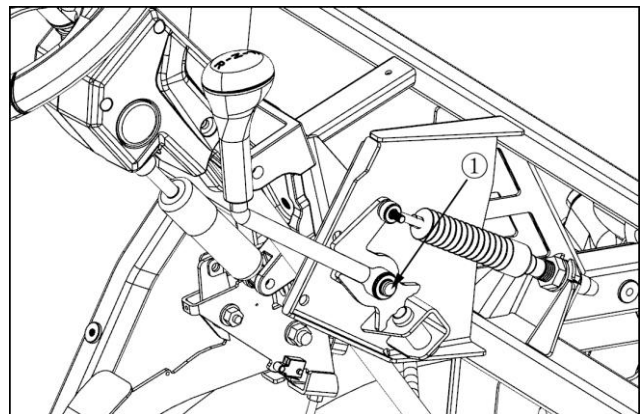

① Range gear shift lever pivot (spray type grease)

■ **Checking tire inflation pressure**

Though the tire pressure is factory-set to the prescribed level, it naturally drops slowly in the course of time, thus check it every day and inflate as necessary.

tire sizes	inflation pressure
Front & Rear: 26x10-12	70kPa (0.7kgf/cm ² , 10psi)

EVERY 50 HOURS

■ **Greasing**

Apply a small amount of multi-purpose grease to the following points every 50 hours. If you operated the vehicle in extremely wet and muddy conditions lubricate grease fittings more often.

■ **Checking engine start system**



CAUTION

TO avoid personal injury

- **Do not allow anyone near the vehicle while testing.**
- **If the vehicle does not pass the test, do not operate the vehicle.**

◆ **Preparation before testing**

1. Place all control levers in the “NEUTRAL” position.
2. Set the parking brake and stop the engine.

◆ **Test the range of the gear shift lever and safety switch**

1. Sit on the operators seat.
2. Shift the range gear shift lever to: “L”, “H”, “N” or REVERSE position.
3. Turn the key to “START” position.
4. The engine must not crank.
5. If it cranks consult your local dealer for this service.

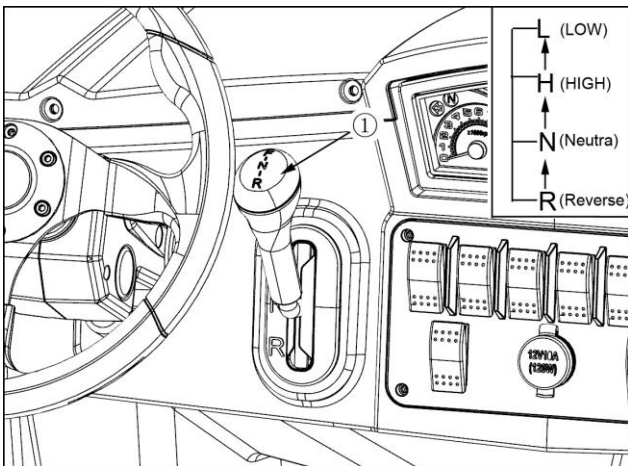

① Gear shift lever

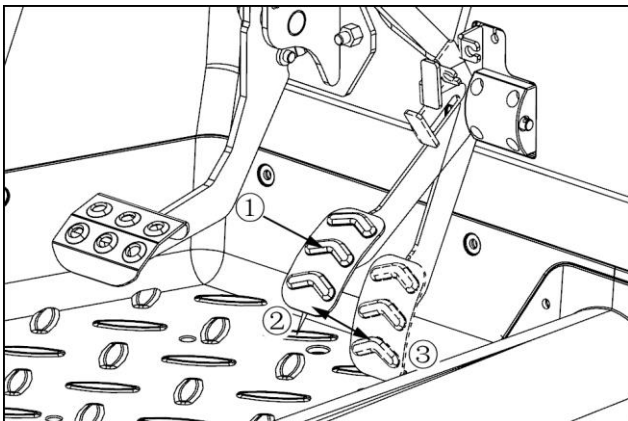

① Accelerator pedal

■ **Checking wheel bolt torque**



CAUTION

To avoid personal injury

- **Never operate vehicle with a loose wheel bolt.**
- **Any loose wheel bolts should be retightened to the specified torque.**
- **Check all bolts frequently and keep them tight.**

Check wheel bolts regularly especially when new if they are loose tighten them as follows:

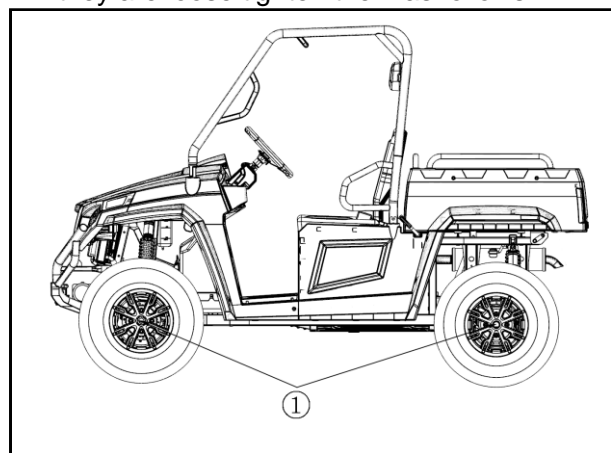

① Torque wheel bolts to 75to 90 N.m

■ **Cleaning air cleaner primary element**

1. Remove the seat.
2. Remove the Engine cover
3. Remove the connecting rubber tube between air cleaner and throttle valve and the screws holding the air cleaner, and then remove the air cleaner.
4. Remove the air filter element.
5. Remove the sponge material from its frame.
6. Wash the sponge material gently but thoroughly in solvent.
7. Squeeze the excess solvent out of the sponge material and let it dry.
8. Inspect the sponge material and replace it if damaged.
9. Thoroughly apply foam air filter oil or other quality liquid foam air filter oil (not spray type) to the sponge material.
10. Pull the sponge material over its frame.

11. Install the air filter element.
12. Install the air filter case cover and be sure the crankcase breather hose is connected.

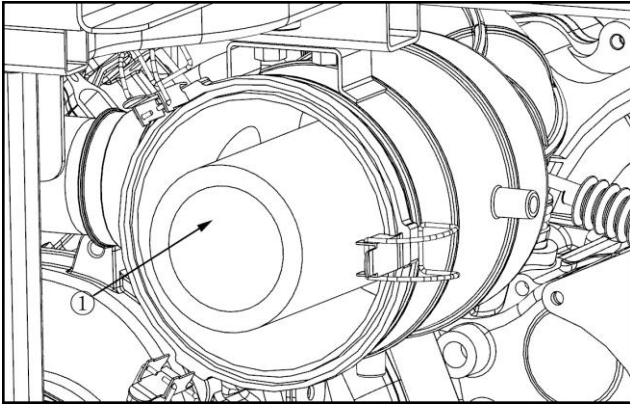

① Air filter element

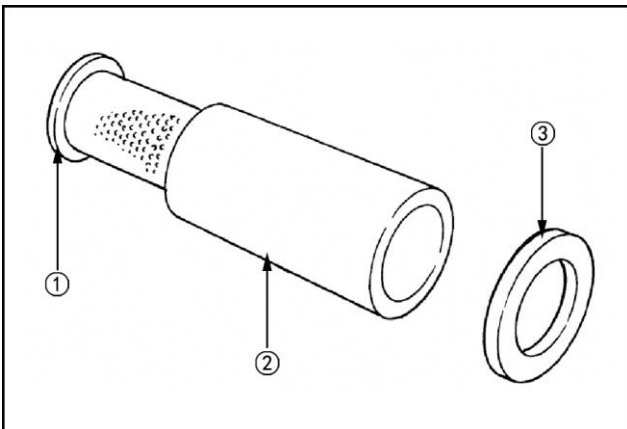

① Air filter frame ② Air filter element
③ Element retaining plate

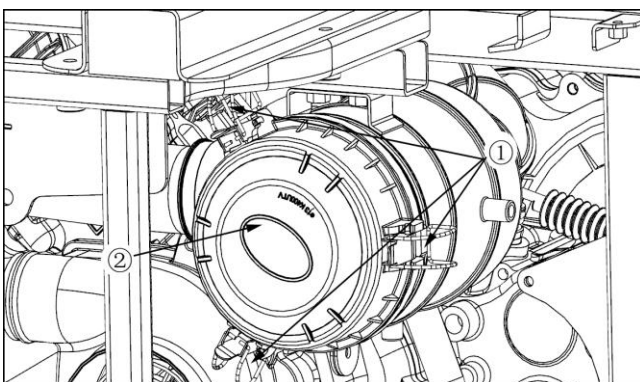

① Holder (×6) ② Air filter case cover

IMPORTANT

- The air cleaner uses a dry element never apply oil.

- Do not run the engine with filter element removed.
- Be sure to refit the cover with the arrow (on the rear of cover) upright if the cover is improperly fitted the evacuator valve will not function and dust will adhere to the element.

◆ **Evacuator Valve**

Open the air cleaner cover once a week under ordinary conditions –or daily when used in a dusty place-to get rid of large particles of dust and dirt. Check fuel line and fuel filter.

CAUTION

To avoid personal injury:

- Be sure to stop the engine and remove the key when attempting to make the following checks and changes.
 - Check the fuel lines periodically. The fuel lines are subject to wear and aging fuel may leak out onto the running engine causing a fire.
 - The fuel line connections should be checked annually or every 100 service hours whichever comes first.
1. Park the vehicle on a flat surface and raise the cargo bed.
 2. The fuel line is made of rubber and ages regardless of service period.
 3. If the fuel line and clamps are found to be damaged or deteriorated replace them.
 4. Check fuel filter if it is clogged by debris or contaminated replace it.

IMPORTANT

When the fuel line is disconnected for maintenance or repair close both ends of the fuel line with a piece of clean cloth or paper to prevent dust and dirt from entering in, care must be taken not to allow dust and dirt into the fuel pump. Even a small amount of dust or dirt can cause premature wear and malfunction of the fuel pump and injector components.

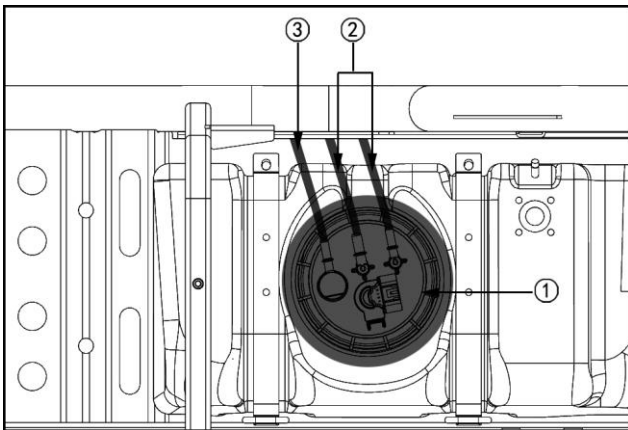

① fuel pump ② fuel line
③ Exit pipe

■ **Checking battery condition**

! DANGER

If do not use or charge the refillable type battery, you must replace new battery.

! CAUTION

To avoid personal injury

- Never remove the battery while the engine is running.
- Keep electrolyte away from eyes, hands and clothes. If you are spattered with it, wash it away completely with water immediately and get medical attention.
- Wear eye protection and rubber gloves when working around the battery.

The factory –installed battery is non-refillable type if the battery is weak, charge the battery or replace it with new one

◆ **Battery charging**

! CAUTION

To avoid personal injury

- When the battery is being activated, hydrogen and oxygen gases in the battery are extremely explosive. Keep open sparks and flames away from the battery at all times, especially when charging the battery.
- When disconnecting the cable from the battery start with the negative terminal first; when connection the cable to the battery start with the positive terminal first.
- Always check battery charge by using a voltmeter.

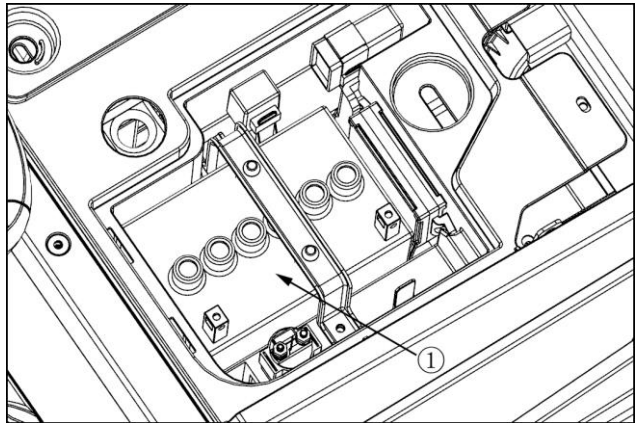

① Battery

1. To slow charge the battery connect the battery positive terminal to the charger positive terminal and the negative to the negative. Then recharge using the instructions on your charger.
2. A boost charge is only for emergencies it will partially charge the battery.
3. When exchanging an old battery for a new one use battery of equal specification shown in table 1.

Battery type	Volts
12V32Ah	12

◆ **Direction for storage**

1. When storing the vehicle for a long period, remove the battery from level vehicle, store in a dry place out of direct sunlight.
2. The battery shall self discharge while it is shored recharge it once every three months in hot seasons and once every six months in cold seasons.

■ **Adjusting toe-in**

Proper toe-in	0 to12 mm (0 to 0.47 in)
---------------	--------------------------

1. Park vehicle on flat place.
2. Turn steering wheel so the front wheels are in the straight ahead position.
3. Set the parking brake and stop the engine.
4. Measure distance between tire beads at rear of tire at hub height.
5. The front distance should be shorter than rear distance. If not, adjust tie rod length.

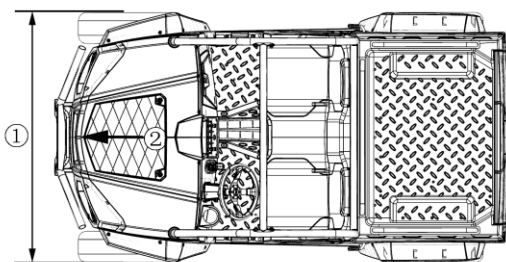

- ① Wheel-to-wheel distance at front
- ② FRONT

◆ **Adjusting procedures**

1. Loosen the lock nut and turn the tie rod to adjust the rod length until the proper toe-in

measurement is obtained.

2. Retighten the lock nut.

IMPORTANT

- Keep an equal length between the left and right tie-rod.

■ **Cleaning Muffler**



To avoid personal injury:

- **Before touching any part of an exhaust system, be absolutely sure that it has sufficient time to cool!**
- **Always wear safety goggles and face mask.**
- **The particulate matter contained in the muffler contains chemicals that are harmful to people, animals and marine life.**
- **If you are unable to do this work, have it done by your dealer.**
- **Cleaning spark arrester of muffler.**

Maintenance & cleanout procedure:

The screen type spark arrester should be removed, cleaned, and inspected after every 100 hours of use.

1. The spark arrester is located inside of the exhaust pipe, and fastened with six bolts.
2. Loosen the bolts and remove the spark arrester.
3. Shake loose particles out of the screen assembly and lightly clean the screen with wire brush. Soak in solvent and again clean with wire brush if necessary.
4. If any breaks in the screen or weldments are discovered, the assembly must be replaced.
5. Return the spark arrester to the muffler body and refasten the bolts.

IMPORTANT:

- Visually check the muffler for cracks or holes in the body, weldment or pipes at regular intervals.
- USDA approval requires clearance between spark arrester sleeve and exhaust pipe to be no larger than 0.023”(0.584 mm).
- Replace the entire muffler if it is damaged.
- Do not operate the vehicle with a damaged muffler.

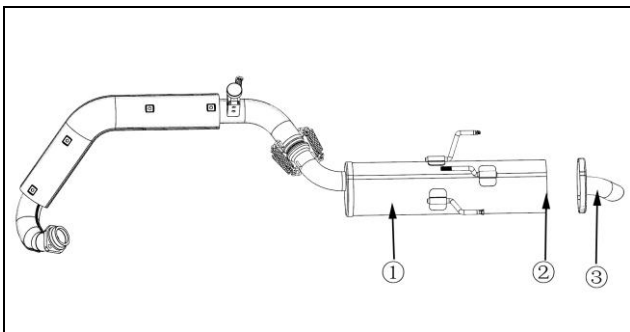

- ① Muffler
- ② Spray fire device
- ③ Muffler cover

EVERY 200 HOURS

■ **Changing Engine Oil**

CAUTION

To avoid personal injury:

- **Be sure to stop the engine before replacing oil.**
 - **Allow engine to cool down sufficiently, oil can be hot and can burn.**
1. Park the vehicle on flat surface and raise the cargo bed.
 2. To drain the used oil, remove the drain plug at the bottom of the engine and completely drain the oil into an oil pan.
 3. After draining, reinstall the drain plug.
 4. Fill with the new oil up to the upper notch on the dipstick.

(See “LUBRICANTS, FUEL AND COOLANT” in “MAINTENANCE” section.)

Oil capacity	[Filter exchanged]	1.8L (1.89U.S. qts.)
	[Filter not exchanged]	1.6L (1.68U.S. qts.)

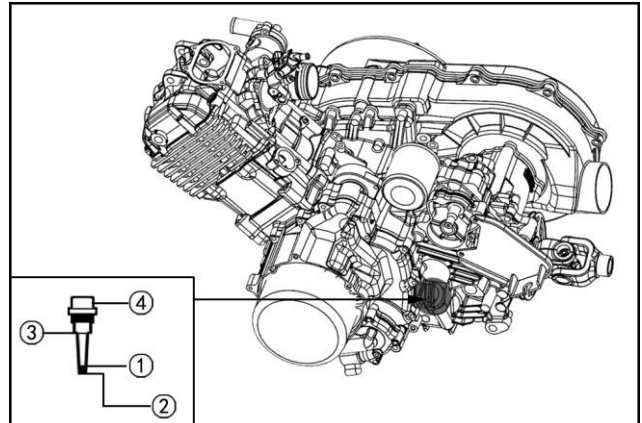

- ① Oil Level
- ② Oil inlet
- ③ Dipstick
- ④ Cap

■ **Replacing Engine Oil Filter**

CAUTION

To avoid personal injury:

- **Be sure to stop the engine before changing the oil filter cartridge.**
 - **Allow engine to cool down sufficiently, oil can be hot and can burn.**
1. Park the vehicle on a flat surface and raise the cargo bed.
 2. Remove the oil filter.
 3. Put a film of clean engine oil on the rubber seal of the new filter.
 4. Tighten the filter quickly until it contacts the mounting surface.
Tighten filter by hand an additional 1/2 turn only.
 5. After the new filter has been replaced, the engine oil normally decreases a little. Make sure that the engine oil does not leak through the seal and check the oil level on the dipstick. Then replenish the engine oil up to the prescribed level.

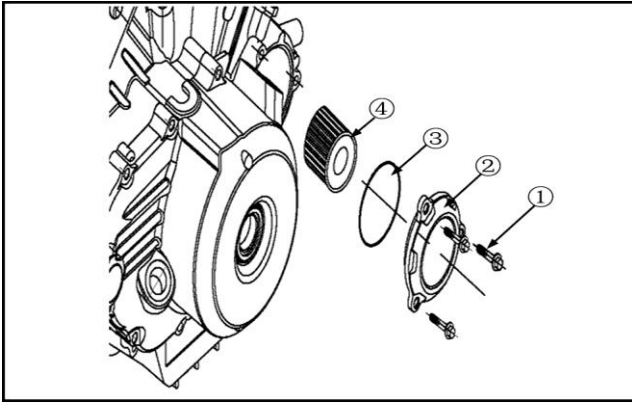

- ① Bolt;
- ② Cover
- ③ "O" seal ring;
- ④ Engine oil filter

IMPORANT:

- To prevent serious damage to the engine, use only a genuine filter.

■ Replacing Transmission Oil



CAUTION

To avoid personal injury:

- Be sure to stop the engine before changing oil.
 - Allow engine to cool down sufficiently, oil can be hot and can burn.
1. Park the vehicle on a flat surface, raise the cargo bed, and mount the safety support.
 2. Replace with clean transmission oil;
 3. Quickly tighten the filter until it contacts the mounting surface, tighten it an additional 1 turn only.
 4. After running the engine for a few minutes, stop the engine and check the oil level again. Add oil to the prescribed level.

Oil capacity	[Filter exchanged]	1L (1.05U.S. qts.)
--------------	--------------------	--------------------

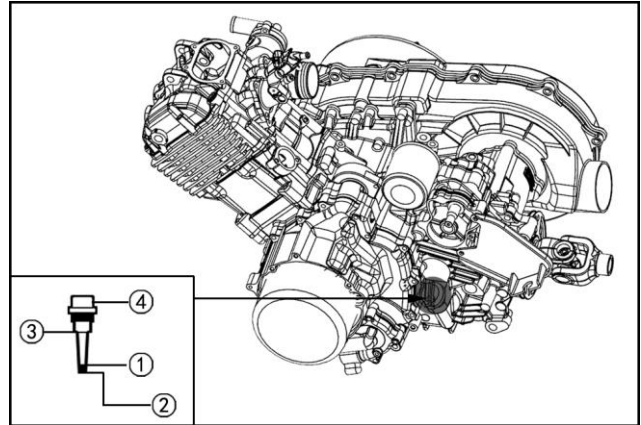

- ① Oil Leve
- ② Oil inlet
- ③ Dipstick
- ④ Cap

■ Checking Brake Pedal



CAUTION

- Stop the engine and chock the wheels before checking brake pedal.
- If movement is outside of the specifications contact your local dealer for adjusting the brake.

◆Checking the brake pedal free travel

Proper brake pedal free travel	7 to 14mm (0.3 to in.)On the pedal
--------------------------------	---------------------------------------

1. Release the parking brake.
2. Slightly depress the brake pedal and measure free travel at the top of the pedal stroke.
3. If brake pedal free travel is outside of the specifications, contact your local dealer for adjusting the brake.

◆ **Checking the brake pedal stroke**

Pedal stroke	Less than 120mm (4.7in.) On the pedal
--------------	--

1. Release the parking brake.
2. Step on the pedal and measure the pedal stroke.
3. If brake pedal stroke is outside of the specifications, contact your local dealer for adjusting the brake.

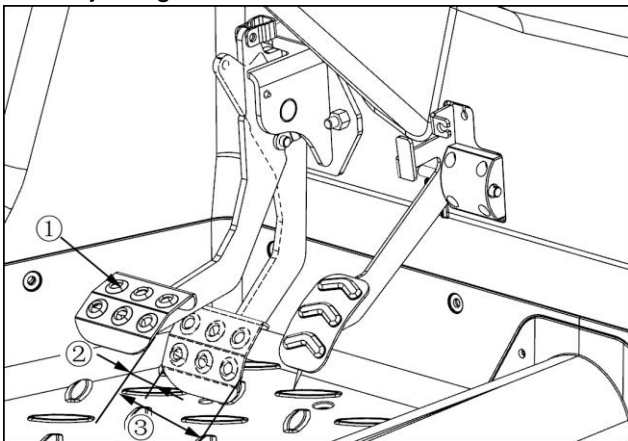

- ① Brake pedal
② "FREE TRAVEL" ③ "PEDAL STROKE"

■ **Checking Brake Hose and Pipe**

1. Check to see that brake hose and pipe are not swollen, hardened or cracked.
2. Check the brake hose and pipe joints for oil leaks.
3. If there is any abnormality, consult your local dealer for this service.

■ **Checking Brake Light Switch**

1. Park the vehicle on a flat surface and raise the cargo bed.
2. Turn the key switch to the "ON" position.
3. Step on the brake pedal to check if the brake light comes on.
4. If it does not, check the bulb or brake light switch.

■ **Checking Radiator Hose and Clamp**

Park the vehicle on a flat surface and raise the

cargo bed. Check to see if radiator hoses are properly attached every 200 hours of operation or six months, whichever comes first.

1. If hose clamps are loose or water leaks, tighten bands securely.
2. Replace hoses and tighten hose clamps securely, if radiator hoses are swollen, hardened or cracked. Replace hoses and hose clamps every 2 years or earlier, if checked and found that hoses are swollen, hardened or cracked.

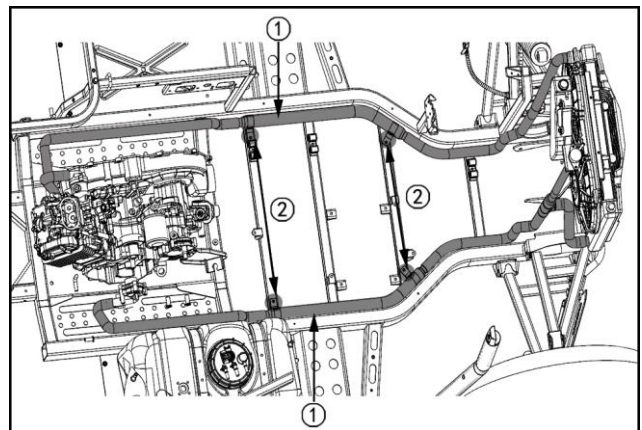

- ① Radiator hose ② Clamp bands

◆ **Precaution at Overheating**

Take the following actions in the event the coolant temperature is close to or more than the boiling point, which is called "Overheating".

1. Stop the vehicle operation in a safe place and keep the engine unloaded idling.
2. Don't stop the engine suddenly, but stop it after about 5 minutes of unloaded idling.
3. Keep well away from the vehicle for at least 10 minutes or while the steam is blowing out.
4. Insure there is no danger such as burning, get rid of the causes of overheating by consulting the "TROUBLESHOOTING" section of this manual, and then start the engine again.

■ **Checking Intake Air Line**

1. Check to see if the hoses and hose clamps are tight and not damaged.
2. If hoses and clamps are found to be worn or damaged, replace or repair them at once.

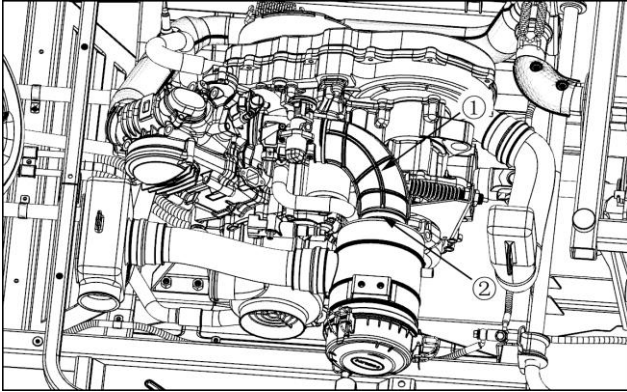

① Hose ② Hose joint

EVERY 300 HOURS

■ **Checking Tire**

1. Check to see if tires are damaged.
2. If the tires are cracked, bulged, or cut, or they are worn out, replace or repair them at once.

◆ **Tire Tread Depth**

Always replace the tires when the tread depth is worn to minimum allowable.

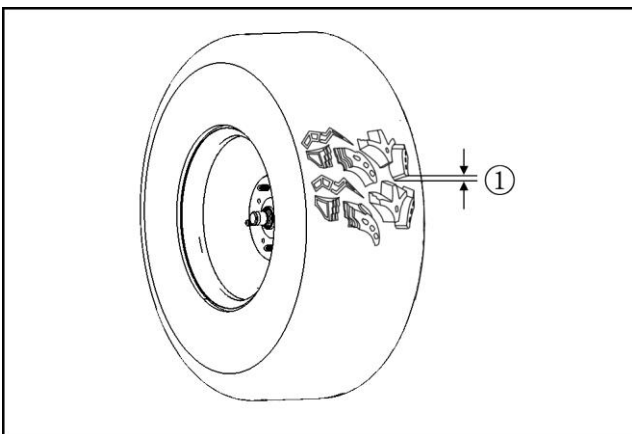

① 3mm(0.12in)

EVERY 400 HOURS

■ **Changing Transmission Fluid**

CAUTION

To avoid personal injury:

- Park the vehicle on a flat surface, raise the cargo bed, and mount the safety support.
- Allow engine to cool down sufficiently, oil can be hot and can burn.

1. Park the vehicle on a flat surface, raise the cargo bed, and mount the safety support.
2. To drain the used oil, remove the drain plug at the bottom of the transmission case and drain the oil completely into the oil pan.
3. After draining, reinstall the drain plug.
4. After running the engine for a few minutes, stop the engine and check the oil level again; add oil to prescribed level.

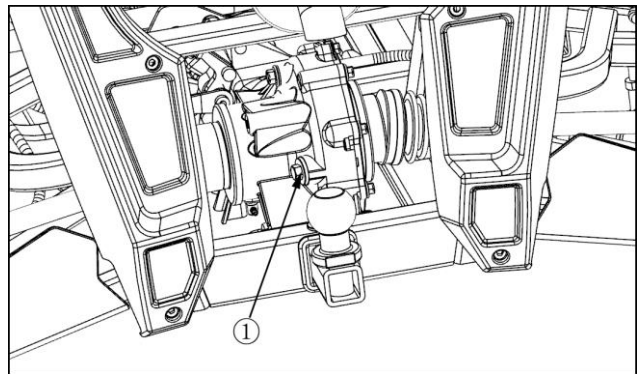

① Drain plug

IMPORTANT:

- Do not operate the vehicle immediately after changing the transmission fluid.
- Run the engine at medium speed for a few minutes to prevent damage to the transmission.

■ **Changing Front and Rear Axle Case Oil**

1. Park the vehicle on a firm, flat and level surface.
2. To drain the used oil, remove the drain plug and drain the oil completely into the oil pan.
3. Fill with the new oil up to the upper notch on

the dipstick.

(See “LUBRICANTS, FUEL AND COOLANT” in “MAINTENANCE” section.)

4. After filling, reinstall the filling plug.

Oil capacity	0.6L (0.6U.S.gals.)
--------------	---------------------

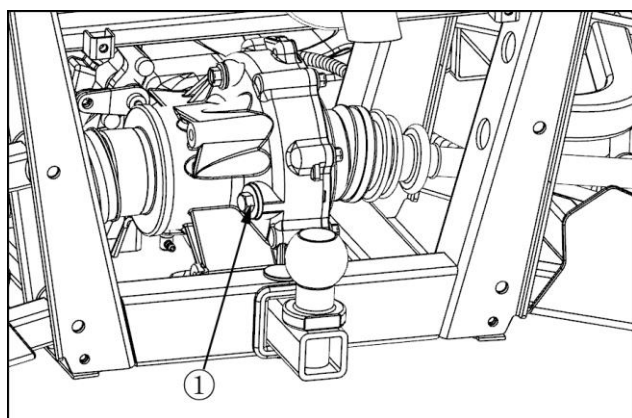

① Drain plug

EVERY 500 HOURS

■ Replacing Fuel Filter

Consult your local dealer for this service.

EVERY 600 HOURS

■ Adjusting Engine Valve Clearance

Consult your local dealer for this service.

EVERY 1500 HOURS

■ Checking Injection and Fuel Pump

Consult your local dealer for this service.

EVERY 1 YEAR

■ Replacing Air Cleaner Primary Element and Secondary Element

(See “Cleaning Air Cleaner Primary Element” in “every 100 HOURS” in “PERIODIC SERVICE” section.)

EVERY 2 YEARS

■ Changing Brake Fluid

Consult your local Dealer for this service.

(See “Checking Brake Fluid Level” in “DAILY CHECK” in “PERIODIC SERVICE” section.)

■ Flushing Cooling System and Changing Coolant



To avoid personal injury:

- Do not remove the radiator cap while coolant is hot. When cool, slowly rotate cap to the first stop and allow sufficient time for excess pressure to escape before removing the cap completely.

1. Stop the engine and let cool down.
2. To drain the coolant, open the radiator drain plug and remove radiator cap. The radiator cap must be removed to completely drain the coolant.
3. After all coolant is drained, close the drain plug.
4. Fill with clean water and cooling system cleaner.
5. Follow directions of the cleaner instruction.
6. After flushing, fill with clean water and anti-freeze until the coolant level is just below the radiator cap.
Install the radiator cap securely.
7. Fill with fresh water up to the “FULL” mark on the recovery tank.
8. Start and operate the engine for few minutes.
9. Stop the engine and let cool.
10. Check coolant level of recovery tank and coolant if necessary.

Coolant capacity	4.0L (4.2U.S.qts.)
------------------	--------------------

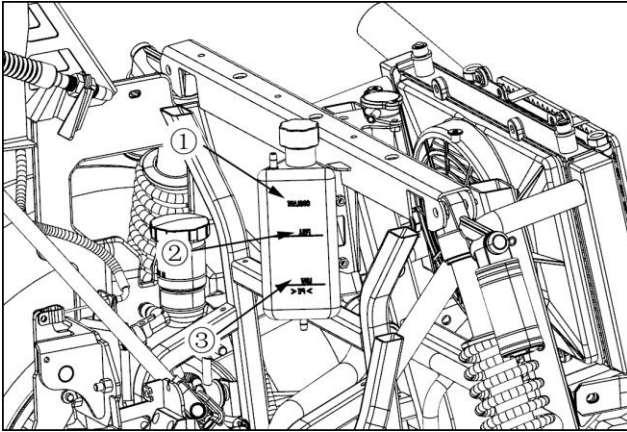

① Recovery tank ② "FULL"
③ "LOW"

IMPORTANT:

- Do not start engine without coolant.
- Use clean, fresh water and anti-freeze to fill the radiator and recovery tank.
- When the anti-freeze is mixed with water, the antifreeze mixing ratio must be less than 50%.
- Securely tighten radiator cap. If the cap is loose or improperly fitted, water may leak out and the engine could overheat.

■ **Anti-Freeze**



CAUTION

To avoid personal injury:

- When using antifreeze, put on some protection such as rubber gloves. (Antifreeze contains poison.)
- If you should drink antifreeze get medical attention immediately.
- When antifreeze comes in contact with the skin or clothing, wash it off immediately.
- Do not mix different types of Antifreeze. The mixture can produce chemical reaction causing harmful substances.
- Antifreeze is extremely flammable and explosive under certain conditions. Keep fire and children away from antifreeze.
- When draining fluids from the engine, place a

container underneath the engine body.

- Do not pour waste onto the ground, down a drain, or into any water source.
- Also, observe environmental protection regulations when disposing of antifreeze.

If it freezes, coolant can damage the cylinders and radiator. If the ambient temperature falls below 0°C(32°F) or before a long-term storage, remove cooling water completely, or mix fresh water with long-life coolant and fill the radiator and recovery tank with the mixture. •

1. Long-life coolant (hereafter LLC) comes in several types. Use ethylene glycol(EG) type for this engine.
2. Before employing LLC-mixed cooling water, fill the radiator with fresh water and empty it again.
Repeat this procedure 2 or 3 times to clean up the inside.
3. The procedure for the mixing of water and antifreeze differs according to the make of the antifreeze and the ambient temperature. Refer to SEA J1034 standard, more specifically also to SAE J814c.

IMPORTANT:

- When the antifreeze is mixed with water, the antifreeze mixing ratio must be less than 50%.

VOL%	Freezing point		Boiling point	
	°C	°F	°C	°F
40	-24	-12	106	222
50	-37	-34	108	226

*At 1.013x10⁵Pa (760mmHg) pressure (atmospheric).

A higher boiling point is obtained by using a radiator pressure cap which permits the development of pressure within the cooling system.

4. Adding the LLC

- 1) Add only water if the mixture reduces in amount by evaporation.
- 2) If there is a mixture leak, add the LLC of the same manufacturer and type in the same mixture percentage.

* Never add any long-life coolant of different manufacturer.(Different brands may have different additive components, and the engine may fail to perform as specified.)

5. When the LLC is mixed, do not employ any radiator cleaning agent. The LLC contains anticorrosive agent. If mixed with the cleaning agent, sludge may build up, adversely affecting the engine parts.
6. The vehicle's original long-life coolant has a service life of 2 years. Be sure to change the coolant every 2 years.

NOTE:

- The above data represents industry standards that necessitate a minimum glycol content in the concentrated antifreeze.
- When the coolant level drops due to evaporation, add water only to keep the antifreeze mixing ratio less than 50%. In case of leakage, add antifreeze and water in the specified mixing ratio before filling into the radiator.

■ Replacing Radiator Hose (Water pipes)

Replace the hoses and clamps.

(See "Checking Radiator Hose and Clamp" in "EVERY 200 HOURS" in "PERIODIC SERVICE" section.)

■ Replacing Fuel Hose

Consult your local HISUN Dealer for this service.

■ Replacing Brake Master Cylinder (Inner parts)

Consult your local dealer for this service.

■ Replacing Front Brake Seal

Consult your local dealer for this service.

■ Replacing Rear Brake Cylinder Seal

Consult your local dealer for this service.

■ Replacing Intake Air Line

Consult your local dealer for this service.

EVERY 4 YEARS

■ Replacing Brake Hose

Consult your local Dealer for this service.

■ Replacing Slow-Blow Fuses

The slow-blow fuses are intended to protect the electrical cabling. If any of them have blown out, be sure to pinpoint the cause.

◆ Replacing procedure

- 1) Disconnect the negative cable of the battery.
- 2) Open the slow-blow fuse box cover.
- 3) Pull out the slow-blow fuse.
- 4) Insert a new slow-blow fuse into the slow-blow fuse box.
- 5) Close the slow-blow fuse box cover.
- 6) Connect the negative battery cable.

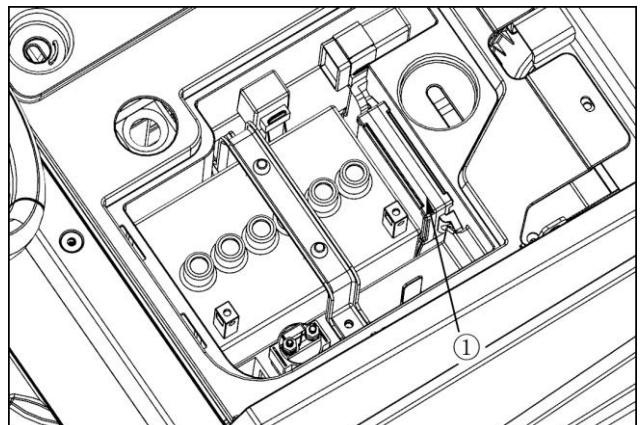

- ① Slow-blow fuse box cover

■ Replacing Light Bulb

- Head lights
Take the bulb out of the light body and replace it with a new one.
- Other lights
Detach the lens and replace the bulb

Light	Capacity
Head lights	2x35W
Tail light	2x5W
Brake light	2x21W
Instrument panel light	2W

STORAGE

STORAGE



CAUTION

To avoid personal injury:

- Do not clean the vehicle when the engine is running.
- To avoid the danger of exhaust fume poisoning, do not operate the engine in a closed building without proper ventilation.
- When storing, remove the key from the key switch to avoid unauthorized persons from operating the vehicle and getting injured.

VEHICLE STORAGE

If you intend to store your vehicle for an extended period of time, follow the procedures outlined below.

These procedures will insure that the vehicle is ready to operate with minimum preparation when it is removed from storage.

1. Check the bolts and nuts for looseness and tighten if necessary.
2. Apply grease to vehicle areas where bare metal will rust also to pivot areas.
3. Unload from cargo bed.
4. Inflate the tire to a pressure a little higher than usual.
5. Charge the engine oil and run the engine to circulate oil throughout the engine block and internal moving parts for about 5 minutes.
6. With all implements lowered to the ground, coat any exposed rods with grease (if equipped).

7. Remove the battery from the vehicle. Store the battery following the battery storage procedures.
8. Keep the vehicle in a dry place where the vehicle is sheltered from the elements. Cover the vehicle.
9. Keep the vehicle indoors in a dry area that is protected from sunlight and excessive heat. If the vehicle must be stored outdoors cover it with a waterproof tarp.
Put boards under the tires to keep dampness away from tires.
Keep the tires out of direct sunlight and extreme heat.

IMPORTANT:

- When washing the vehicle, stop the engine. Allow sufficient time for the engine to cool before washing.
- Do not wash with a high-pressure car-washing machine.
- Cover the vehicle after the muffler and the engine have cooled down.

REMOVING THE VEHICLE FROM STORAGE

1. Check the tire air pressure and inflate the tires if they are low.
2. Install battery before installing the battery, Be sure it is fully charged.
3. Check to see if the fan works.
4. Check all fluid levels (engine oil, transmission oil, engine coolant, transmission coolant and any attached implements).
5. Start the engine. Observe all gauges. If all

gauges are functioning properly and reading normal, move the vehicle outside. Once outside, park the vehicle and let the engine idle for at least five minutes. Shut the engine off and walk around vehicle and make a visual inspection looking for evidence of oil or water leaks.

- 6). With the engine fully warm up, release the parking brake and test the brakes for proper adjustment as you move forward. Adjust the brake as necessary.

TROUBLESHOOTING

ENGINE TROUBLESHOOTING

If something is wrong with the engine, refer to the table below for the cause and its corrective countermeasure.

Trouble	Cause	Countermeasure
Engine is difficult to start or cannot start.	<ul style="list-style-type: none"> No fuel flow 	<ul style="list-style-type: none"> Check the fuel tank and fuel filter. Check the electric fuel pump. Check the injector. Check the ECU with Motor Scan KF90121. Replace filter electric fuel pump injector and ECU If necessary.
	<ul style="list-style-type: none"> Water is in the fuel system 	<ul style="list-style-type: none"> Check to see if the fuel tank cover is tight.
	<ul style="list-style-type: none"> In winter, oil viscosity increases, and Engine revolution is slow. 	<ul style="list-style-type: none"> Use oils of different viscosities, depending on ambient temperatures.
	<ul style="list-style-type: none"> Battery becomes weak and the engine does not turn over quick enough. 	<ul style="list-style-type: none"> Clean battery cables and terminals. Charge the battery. In cold weather (-15°C), always remove the battery from the vehicle, charge and store it indoors. install it on the vehicle only when the vehicle is going to be used.
Engine power is insufficient	<ul style="list-style-type: none"> Insufficient fuel. The injector is clogged. Crankshaft position sensor is Spoiled. The air cleaner is clogged. Spark plug is dirty or spoiled. Ignition coil is spoiled. 	<ul style="list-style-type: none"> Check the fuel system. Clean or replace the injector. Replace crankshaft position sensor. Clean or replace the air cleaner. Clean or replace the spark plug. Replace the ignition coil.
Engine stops suddenly	<ul style="list-style-type: none"> Check with the diagnostic instrument (Motor Scan KF90121). 	
Engine overheats	<ul style="list-style-type: none"> Engine overloaded 	<ul style="list-style-type: none"> Shift to lower gear or reduce load.
	<ul style="list-style-type: none"> Low coolant level. 	<ul style="list-style-type: none"> Fill cooling system to the correct level; Check radiator and hoses for loose connections or leaks.
	<ul style="list-style-type: none"> The motor driven fan does not turn. 	<ul style="list-style-type: none"> Check to see if the fuse is not blown. Check the electric system.
	<ul style="list-style-type: none"> Dirty radiator core or grille screens. 	<ul style="list-style-type: none"> Remove all trash.
	<ul style="list-style-type: none"> Coolant flow route corroded. 	<ul style="list-style-type: none"> Flush cooling system.

If you have any questions, consult your local dealer.

Check malf code meaning by reading the below table.

Mt05	ECU	Malf	Code
Table:23			
Malf code in MT05	Description		
P0107	MAP Circuit Low Voltage or Open		
P0108	MAP Circuit High Voltage		
P0112	IAT Circuit Low Voltage		
P0113	IAT Circuit High Voltage or Open		
P0117	Coolant/Oil Temperature Sensor Circuit Low Voltage		
P0118	Coolant/Oil Temperature Sensor Circuit High Voltage or Open		
P0122	TPS Circuit Low Voltage or Open		
P0123	TPS Circuit High Voltage		
P0131	O2A Circuit Low Voltage		
P0132	O2A Circuit High Voltage		
P0031	O2A Heater Circuit High Voltage		
P0032	O2A Heater Circuit Low Voltage		
P0201	Injector 1 Circuit Malfunction		
P0202	Injector 2 Circuit Malfunction		
P0230	FPR Coil Circuit Low Voltage or Open		
P0232	FPR Coil Circuit High Voltage		
P0336	CKP Sensor Noisy Signal		
P0337	CKP Sensor No Signal		
P0351	Cylinder 1 Ignition Coil Malfunction		
P0352	Cylinder 2 Ignition Coil Malfunction		
P0505	Idle Speed Control Error		
P0562	System Voltage Low		
P0563	System Voltage High		
P0650	MIL Circuit Malfunction		
P1693	Tachometer Circuit Low Voltage		
P1694	Tachometer Circuit High Voltage		

If you have any questions, consult your local dealer.

BATTERY TROUBLESHOOTING

Trouble	Cause	Countermeasure	Preventive measure
Starter does not function	<ul style="list-style-type: none"> ● Battery overused until lights are dim. 	<ul style="list-style-type: none"> ● Charge the battery sufficiently. 	<ul style="list-style-type: none"> ● Charge the battery properly.
	<ul style="list-style-type: none"> ● Battery has not been recharged. 		
	<ul style="list-style-type: none"> ● Poor terminal connection 	<ul style="list-style-type: none"> ● Clean the terminal and tighten securely. 	<ul style="list-style-type: none"> ● Keep the terminal clean and tight. Apply grease and treat with anti-corrosive.
	<ul style="list-style-type: none"> ● Battery life expired 	<ul style="list-style-type: none"> ● Replace new battery 	
From beginning starter does not function, and lights soon become dim	<ul style="list-style-type: none"> ● Insufficient charging 	<ul style="list-style-type: none"> ● Charge battery Insufficiently 	<ul style="list-style-type: none"> ● Battery must be serviced properly before initial use
When viewed from the top of plates, look whitish. * Refillable type battery only	<ul style="list-style-type: none"> ● Battery was used with an insufficient amount of electrolyte. 	<ul style="list-style-type: none"> ● Add distilled water and charge the battery. 	<ul style="list-style-type: none"> ● Regularly check the electrolyte level.
	<ul style="list-style-type: none"> ● Battery was used with too much without recharging. 	<ul style="list-style-type: none"> ● Charge battery Insufficiently 	<ul style="list-style-type: none"> ● Charge battery properly
Recharging is impossible.	<ul style="list-style-type: none"> ● Battery life expired. 	<ul style="list-style-type: none"> ● Replace battery. 	
Terminals are severely corroded and heat up.	<ul style="list-style-type: none"> ● Poor terminal connection 	<ul style="list-style-type: none"> ● Clean the terminal and tighten securely. 	<ul style="list-style-type: none"> ● Keep the terminal clean and tight. Apply grease and treat with anti-corrosives.
Battery electrolyte level drops rapidly. * Refillable type battery only	<ul style="list-style-type: none"> ● There is a crack or pin holes in the electrolytic cells. 	<ul style="list-style-type: none"> ● Replace battery. 	
	<ul style="list-style-type: none"> ● Charging system trouble. 	<ul style="list-style-type: none"> ● Consult your local dealer. 	

- If you have any questions, consult your local dealer.
- The factory installed battery is non-refillable type.

MACHINE TROUBLESHOOTING

Trouble	Cause	Countermeasure
Trouble shifting gears	<ul style="list-style-type: none"> ● High idling speed of engine 	<ul style="list-style-type: none"> ● Replace throttle cable ● Replace throttle pedal ● Replace the throttle
	<ul style="list-style-type: none"> ● High rotary speed for clutch connection. 	<ul style="list-style-type: none"> ● Replace the junior clutch spring; ● Replace the primary clutch.
	<ul style="list-style-type: none"> ● Gearshift cable is out of adjustment. 	<ul style="list-style-type: none"> ● Put the gearshift rod into the position of "N". ● Put the gearshift arm of engine into "N". ● Adjust the shift cable and the bolt. ● Lock tightly.
	<ul style="list-style-type: none"> ● Gear abrasion 	<ul style="list-style-type: none"> ● Replace the gears
Transmission noise	<ul style="list-style-type: none"> ● Poor clearance for the inner and outside gears of transmission shaft 	<ul style="list-style-type: none"> ● Replace the gears
	<ul style="list-style-type: none"> ● Poor clearance of transmission gears. 	<ul style="list-style-type: none"> ● Replace the gears
	<ul style="list-style-type: none"> ● Poor connection of gear end face 	<ul style="list-style-type: none"> ● Replace the gears
Reduced vehicle power	<ul style="list-style-type: none"> ● Parking brake engaged 	<ul style="list-style-type: none"> ● Loosen the parking brake
	<ul style="list-style-type: none"> ● Hydraulic disc braking system is activated 	<ul style="list-style-type: none"> ● Contact servicing dealer.
	<ul style="list-style-type: none"> ● CVT transmission sliding 	<ul style="list-style-type: none"> ● Removing the grease for the clutch. ● Replace CVT transmission belt ● Servicing dealer to replace the clutch.
Brake noise	<ul style="list-style-type: none"> ● Insufficient brake oil 	<ul style="list-style-type: none"> ● Check the braking oil level
	<ul style="list-style-type: none"> ● Air inside the braking system. 	<ul style="list-style-type: none"> ● Contact servicing dealer.
	<ul style="list-style-type: none"> ● Brake discs abrasion 	<ul style="list-style-type: none"> ● Contact servicing dealer.
	<ul style="list-style-type: none"> ● Assembling bolt of disc plate loose 	<ul style="list-style-type: none"> ● Lock tightly
	<ul style="list-style-type: none"> ● Assembling bolt for disc brake clippers loose 	<ul style="list-style-type: none"> ● Lock tightly

If you have any questions, consult your local dealer.

OPTIONS

Consult your local dealer for further details.

1. Head rest;
2. Plastic Canopy;
3. Rear Trailer Hitch & Pin(2");
4. Windshield;
5. Steel Cab;
6. Motor Scan KF90121;

2017 VECTOR WARRANTY

HISUN MOTORS CORP., 301 E. University Drive, McKinney, TX 75069 (HISUN) gives the below LIMITED WARRANTY on all components of your HISUN vehicle against defects in material or workmanship.

Warranty Terms by model:

- All Vector Utility Vehicle Models – 1 year

HISUN further warrants that the spark arrester in this product will meet the efficiency requirements of USFS standard 5100-1C for at least 1000 hours when subjected to normal use and when maintenance and installation are in accordance with HISUN recommendations.

This warranty covers parts and labor charges for repair or replacement of defective parts and begins on the date of purchase by the original retail purchaser. This warranty is transferable to another owner during the warranty period through a HISUN dealer, but any such transfer will not extend the original term of the warranty. The duration of this warranty may vary by international region based upon local laws and regulations.

Registration

At the time of sale, the Warranty Registration Form must be completed by your dealer and submitted to HISUN within ten days of purchase. Upon receipt of this registration, HISUN will record the registration for warranty. No verification of registration will be sent to the purchaser as the copy of the Warranty Registration Form will be your proof of warranty coverage. If you have not signed the original registration and received the customer copy, please contact your dealer immediately. **NO WARRANTY COVERAGE WILL BE ALLOWED UNLESS YOUR VEHICLE IS REGISTERED WITH HISUN.** Initial dealer preparation and set-up of your vehicle is very important in ensuring trouble-free operation. Purchasing a machine in the crate or without proper dealer set-up will void your warranty coverage.

Warranty Coverage and Exclusions:

Limitations of Warranties and Remedies

This HISUN limited warranty excludes any failures that are not caused by a defect in material or workmanship. **THIS WARRANTY DOES NOT COVER CLAIMS OF DEFECTIVE DESIGN.** This warranty also does not cover acts of God, accidental damage, normal wear and tear, abuse or improper handling. This warranty also does not cover any vehicle, component, or part that has been altered structurally, modified, neglected, improperly maintained or used for racing, competition or purposes other than for which it was designed.

This warranty excludes damages or failures resulting from improper lubrication; improper engine timing; improper fuel; surface imperfections caused by external stress, heat, cold or contamination; operator error or abuse; improper component alignment, tension, adjustment or altitude compensation; snow, water, dirt or other foreign substance ingestion/contamination; improper maintenance; modified components; use of aftermarket or unapproved components, accessories, or attachments; unauthorized repairs; or repairs made after the warranty period expires or by an unauthorized repair center.

2017 VECTOR WARRANTY

Limitations of Warranties and Remedies

This warranty excludes damages or failures caused by abuse, accident, fire, or any other cause other than a defect in materials or workmanship and provides no coverage for consumable components, general wear items, or any parts exposed to friction surfaces, stresses, environmental conditions and/or contamination for which they were not designed or not intended, including but not limited to the following items:

- Wheels and Tires
- Finished and unfinished surfaces
- Suspension components
- Throttle body components
- Brake components
- Engine components
- Seat components
- Drive belts
- Clutches and components
- Hydraulic components and fluids
- Steering components
- Circuit breakers/Fuses
- Batteries
- Electronic components
- Light bulbs/Sealed beam lamps
- Spark plugs
- Filters
- Sealants
- Lubricants
- Coolants
- Bushings
- Bearings

Lubricants and Fluids

1. Mixing oil brands or using non-recommended oil may cause engine damage. We recommend the use of HISUN engine oil.

2. Damage or failure resulting from the use of non-recommended lubricants or fluids is not covered by this warranty.

This warranty provides no coverage for personal loss or expense, including mileage, transportation costs, hotels, meals, shipping or handling fees, product pick-up or delivery, replacement rentals, loss of product use, loss of profits, or loss of vacation or personal time.

THE EXCLUSIVE REMEDY FOR BREACH OF THIS WARRANTY SHALL BE, AT HISUN' OPTION, REPAIR OR REPLACEMENT OF ANY DEFECTIVE MATERIALS, COMPONENTS, OR PRODUCTS. THE REMEDIES SET FORTH IN THIS WARRANTY ARE THE ONLY REMEDIES AVAILABLE TO ANY PERSON FOR BREACH OF THIS WARRANTY. HISUN SHALL HAVE NO LIABILITY TO ANY PERSON FOR INCIDENTAL, CONSEQUENTIAL OR SPECIAL DAMAGES OF ANY DESCRIPTION, WHETHER ARISING OUT OF EXPRESS OR IMPLIED WARRANTY OR ANY OTHER CONTRACT, NEGLIGENCE, OR OTHER TORT OR OTHERWISE. THIS EXCLUSION OF CONSEQUENTIAL, INCIDENTAL, AND SPECIAL DAMAGES IS INDEPENDENT FROM AND SHALL SURVIVE ANY FINDING THAT THE EXCLUSIVE REMEDY FAILED OF ITS ESSENTIAL PURPOSE. THE IMPLIED WARRANTY OF FITNESS FOR A PARTICULAR PURPOSE IS EXCLUDED FROM THIS LIMITED WARRANTY. ALL OTHER IMPLIED WARRANTIES (INCLUDING BUT NOT LIMITED TO THE IMPLIED WARRANTY OF MERCHANTABILITY) ARE LIMITED IN DURATION TO THE ABOVE SIX MONTH WARRANTY PERIOD. HISUN DISCLAIMS ALL EXPRESS WARRANTIES NOT STATED IN THIS WARRANTY. SOME STATES DO NOT PERMIT THE EXCLUSION OR LIMITATION OF INCIDENTAL OR CONSEQUENTIAL DAMAGES OR ALLOW LIMITATIONS ON THE DURATION OF IMPLIED WARRANTIES, SO THE ABOVE LIMITATIONS MAY NOT APPLY TO YOU IF INCONSISTENT WITH CONTROLLING STATE LAW.

2017 VECTOR WARRANTY

How to Obtain Warranty Service

If your vehicle requires warranty service, you must take it to a HISUN Servicing Dealer. When requesting warranty service you must present your copy of the **Warranty Registration Form** to the dealer. (THE COST OF TRANSPORTATION TO AND FROM THE DEALER IS YOUR RESPONSIBILITY). HISUN suggests that you use your original selling dealer; however, you may use any HISUN Servicing Dealer to perform warranty service.

In the Country where your product was purchased:

Warranty or Service Bulletin repairs must be done by an authorized HISUN dealer. If you move or are traveling within the country where your product was purchased, Warranty and Service Bulletin repairs may be requested from any authorized HISUN dealer that sells the same line as your product.

Outside the Country where your product was purchased:

If you are traveling temporarily outside the country where your product was purchased, you should take your product to an authorized HISUN dealer. You must show the dealer photo identification from the country of the selling dealer's authorized location as proof of residence. Upon residence verification, the servicing dealer will be authorized to perform the warranty repair.

If you purchase from a private party:

If you purchase a HISUN product from a private party, to be kept and used outside of the country in which the product was originally purchased, all warranty coverage will be denied. You must nonetheless register your product under your name and address with a local HISUN dealer in your country to ensure that you receive safety information and notices regarding your product.

Exported Products

EXCEPT WHERE SPECIFICALLY REQUIRED BY LAW, THERE IS NO WARRANTY OR SERVICE BULLETIN COVERAGE ON THIS PRODUCT IF IT IS SOLD OUTSIDE THE COUNTRY OF THE SELLING DEALER'S AUTHORIZED LOCATION. This policy does not apply to products that have received authorization for export from HISUN. Dealers may not give authorization for export. You should consult an authorized dealer to determine this product's warranty or service coverage if you have any questions. This policy does not apply to products registered to government officials or military personnel on assignment outside the country of the selling dealer's authorized location. This policy does not apply to Safety Bulletins.

Notice

If your product is registered outside of the country where it was purchased and you have not followed the procedure set above, your product will no longer be eligible for warranty or service bulletin coverage of any kind, other than safety bulletins. Products registered to government officials or military personnel on assignment outside of the country where the product was purchased will continue to be covered by the Limited Warranty.

Please work with your dealer to resolve any warranty issues. Should your dealer require any additional assistance, they will contact the appropriate person at HISUN.

This warranty gives you specific legal rights, and you may also have other rights which vary from state to state or in different countries. If any of the above terms are void because of federal, state, local law, all other warranty terms will remain in effect.

For questions call HISUN Customer Assistance: United States & Canada: 1-877-838-6188

2017 VECTOR WARRANTY

U.S.A. EPA Emissions Limited Warranty

This emissions limited warranty is in addition to the HISUN standard limited warranty for your vehicle. HISUN Industries Inc. warrants that at the time it is first purchased, this emissions-certified vehicle is designed, built and equipped so it conforms to applicable U.S. Environmental Protection Agency emission regulations. HISUN warrants that the vehicle is free from defects in materials and workmanship that would cause it to fail to meet these regulations.

The warranty period for off road vehicles 100cc or greater emissions-certified vehicles starts on the date of purchase by original retail purchaser and continues for a period of 500 hours of engine operation, 3100 miles of vehicle travel, or 30 calendar months from the date of purchase, whichever comes first.

The warranty period for ATVs less than 100cc emissions-certified vehicles starts on the date of purchase by original retail purchaser and continues for a period of 250 hours of engine operation, 1550 miles of vehicle travel, or 30 calendar months from the date of purchase, whichever comes first.

This EPA emissions warranty period is extended for at least as long as the standard factory warranty that HISUN provides on the vehicle as a whole. The EPA emissions warranty period does not further extend if you purchase additional warranty coverage in the form of a service contract or other paid warranty extension, but emission-related parts may be covered subject to the terms of any such paid service contract or paid warranty extension.

This emissions limited warranty covers components whose failure increases the vehicle's regulated emissions, and it covers components of systems whose only purpose is to control emissions. Repairing or replacing other components not covered by this warranty is the responsibility of the vehicle owner. This emissions limited warranty does not cover components whose failure does not increase the vehicle's regulated emissions.

For exhaust emissions, emission-related components include any engine parts related to the following systems:

- Air-induction system
- Ignition system
- Fuel system
- Exhaust gas recirculation systems

The following parts are also considered emission-related components for exhaust emissions:

- After treatment devices
- Sensors
- Crankcase ventilation valves
- Electronic control units

The following parts are considered emission-related components for evaporative emissions:

- Fuel Tank
- Vacuum Control Diaphragms*
- Fuel Cap
- Control Cables*
- Fuel Line
- Control Linkages*
- Fuel Line Fittings
- Purge Valves
- Clamps*
- Vapor Hoses
- Pressure Relief Valves*
- Liquid/Vapor Separator
- Control Valves*
- Carbon Canister
- Control Solenoids*
- Canister Mounting Brackets
- Electronic Controls*
- Carburetor Purge Port Connector

*As related to the evaporative emission control system.

2017 VECTOR WARRANTY

Emission-related components also include any other part whose only purpose is to reduce emissions or whose failure will increase emissions without significantly degrading engine/equipment performance. The exclusive remedy for breach of this limited warranty shall be, at the exclusive option of HISUN, repair or replacement of any defective materials, components or products.

THE REMEDIES SET FORTH IN THIS LIMITED WARRANTY ARE THE ONLY REMEDIES AVAILABLE TO ANY PERSON FOR BREACH OF THIS WARRANTY. HISUN SHALL HAVE NO LIABILITY TO ANY PERSON FOR INCIDENTAL, CONSEQUENTIAL OR SPECIAL DAMAGES OF ANY DESCRIPTION, WHETHER ARISING OUT OF EXPRESS OR IMPLIED WARRANTY OR ANY OTHER CONTRACT, NEGLIGENCE OR OTHER TORT OR OTHERWISE. THIS EXCLUSION OF CONSEQUENTIAL, INCIDENTAL, AND SPECIAL DAMAGES IS INDEPENDENT FROM AND SHALL SURVIVE ANY FINDING THAT THE EXCLUSIVE REMEDY FAILED OF ITS ESSENTIAL PURPOSE.

ALL IMPLIED WARRANTIES (INCLUDING BUT NOT LIMITED TO ANY IMPLIED WARRANTIES OF MERCHANTABILITY AND FITNESS FOR A PARTICULAR PURPOSE) ARE LIMITED IN DURATION TO THE WARRANTY PERIOD DESCRIBED HEREIN. HISUN DISCLAIMS ALL EXPRESS WARRANTIES NOT STATED IN THIS WARRANTY. Some states do not allow limitations on how long an implied warranty lasts, so the above limitation may not apply if it is inconsistent with the controlling state law.

This limited warranty excludes failures not caused by a defect in material or workmanship. This limited warranty does not cover damage due to accidents, abuse or improper handling, maintenance or use. This limited warranty also does not cover any engine that has been structurally altered, or when the vehicle has been used in racing competition. This limited warranty also does not cover physical damage, corrosion or defects caused by fire, explosions or other similar causes beyond the control of HISUN.

Owners are responsible for performing the scheduled maintenance identified in the owner's manual. HISUN may deny warranty claims for failures that have been caused by the owners or operator's improper maintenance or use, by accidents for which HISUN has no responsibility, or by acts of God. Any qualified repair shop or person may maintain, replace, or repair the emission control devices or systems on your vehicle. An authorized HISUN dealer can perform any service that may be necessary for your vehicle. HISUN also recommends HISUN parts, however equivalent parts may be used for such service. It is a potential violation of the Clean Air Act if a part supplied by an aftermarket parts manufacturer reduces the effectiveness of the vehicle's emission controls. Tampering with emission controls is prohibited by federal law.

If you have any questions regarding your warranty rights and responsibilities, please contact HISUN Customer Assistance: United States & Canada: 1-877-838-6188.



HISUN[™]
GRAB SOME SUN

HISUN MOTORS

310 East University Dr
McKinney, Texas 75069

PH (972) 446-0760

hisunmotors.com