

PRODUCT SPECIFICATIONS

2ft LED Wrap Light

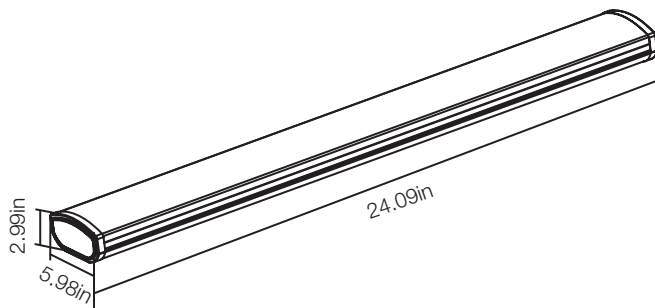

54655241
SKU# 1001397562



SPECIFICATIONS

Model Number	54655241
SKU	1001397562
OSMID	206032015
Power	22 W
AC Voltage, Frequency	120V, 60 Hz
Color Temp (nom.)	4000K
Operation Temp	-4°F ~ 113°F
CRI	80
Lumen Output (min.)	1800 lm
Dimming	NO
Lifetime Rating	L70/50000Hrs
Efficacy	81.8 lm/watt

ADVANTAGES

- 50,000 Hours of Continuous Use
- 7/8" Knockouts (3)

APPLICATIONS

Suitable for damp locations

SURFACE MOUNT



PACKAGING

Weight (±0.5 lb)	2.23 lbs
Size (L x W x H) (±0.1 in)	24.09in x 5.98in x 2.99in
Box Dimensions	27.83in x6.89in x3.78in
Gross Weight	3.19 lbs
UPC	849489001906



INCLUDED IN BOX

- Mounting Screw (2)
- Mounting Bracket (1)
- Outlet Box Screw (2)
- Wire nut (1)
- Drywall Anchor For Mounting Screw (2)
- Connector (1)
- Gasket (1)