

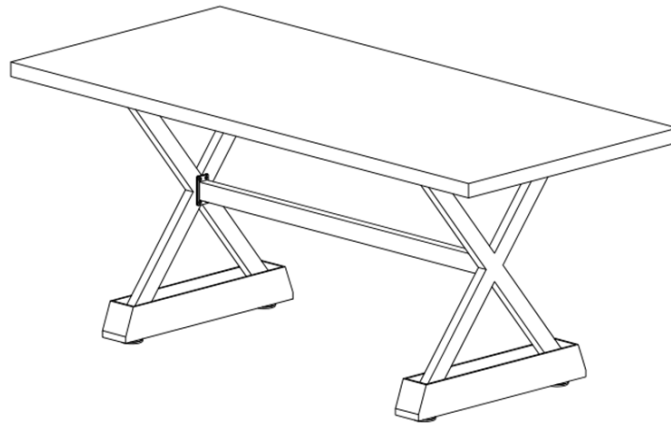



# Assembly Instructions

**Caution : You must read this before you proceed  
The Table and its Parts are Heavy.  
At least two adults are required for lifting and moving them.**





## Table



### Part List

Label	Picture	Description	QTY
1		Table Top	1
2		Leg	2
3		Connecting Bar	1

### Hardware





Label	Picture	Description	QTY
A		Bolt (M6*16MM)	25
B		Spring Washer	25
C		Washer (M6*16)	17
D		Washer (M6*12)	9

E		Allen Key	1
---	---	-----------	---

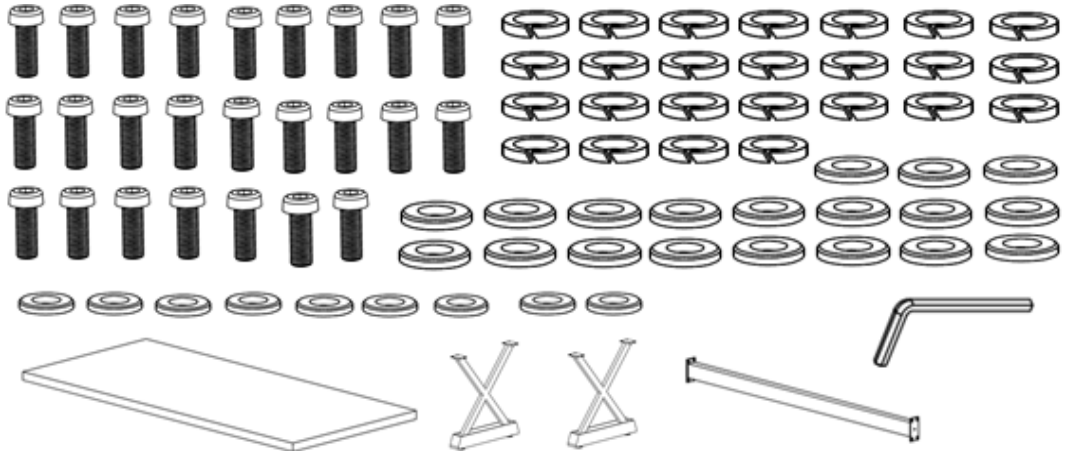
## Assembly Preparation

Before Beginning Assembly:



-  • Read instructions, cover to cover-
-  • Have 2 adults on hand for assembly-
-  • Do not assemble on flooring or carpet-
-  • Assemble on a clean non-marring surface (packing foam)-
-  • Save all packaging until finished-

## Assembly Steps

### Overview

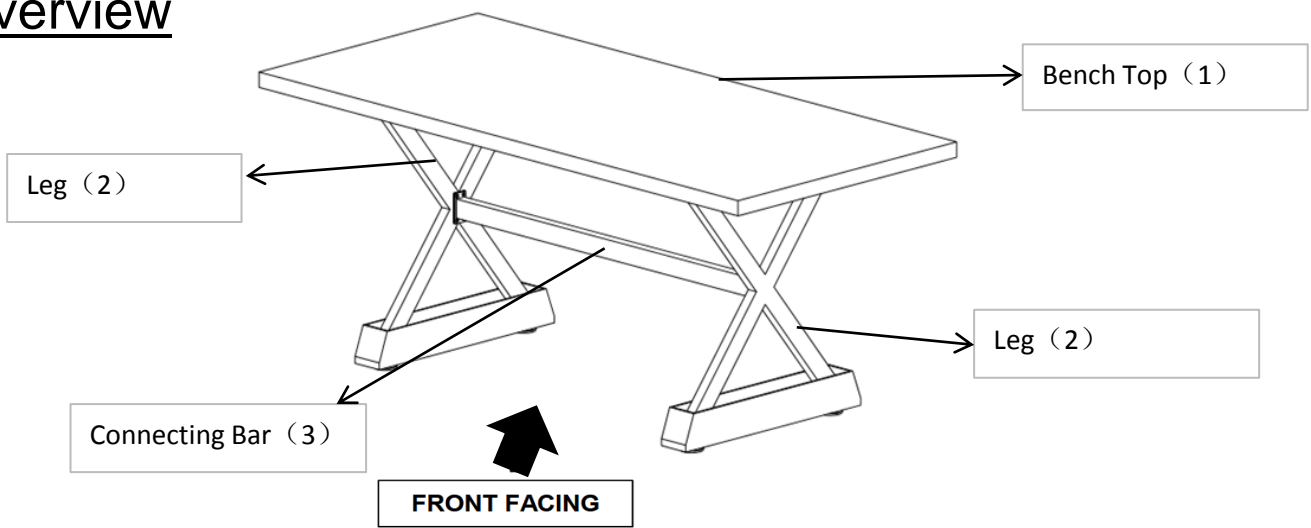

This Table has multiple parts and may require up to some 30 minutes to assemble. To give you an overview of the Table parts, the above picture is to help you put the various parts into perspective. Please read through the instructions herebelow to familiarise yourself with the parts and steps before assembly.

**Some parts are heavy, exercise safety and have 2 adult assistants to help whenever lifting and moving them.**

## Assembly Steps

### Step 1

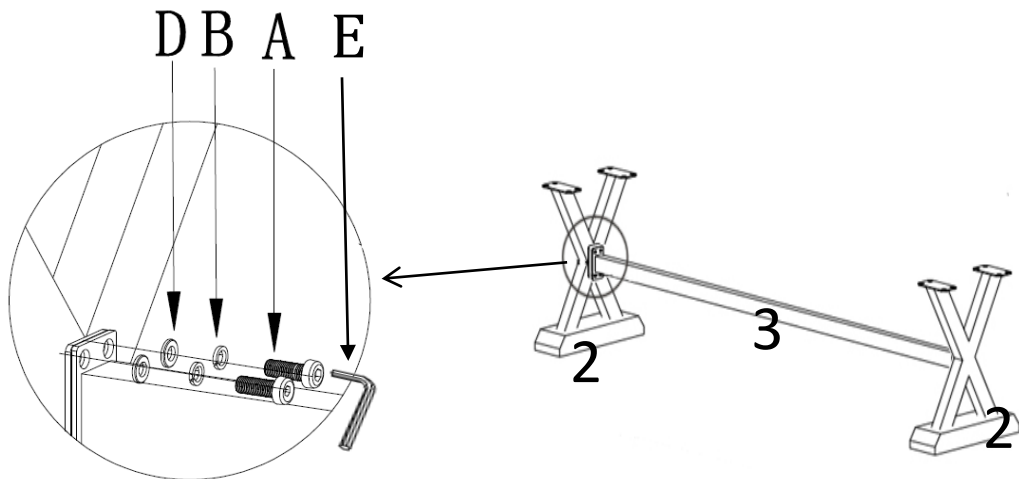

Unpack and place all parts on a clean, non-marring surface.

Stand the Leg(2) up as shown.

With the assistance of your adult partner, align the mountings of the Connection Bar(3) to the mountings on the Leg(2).

Attach the Connection Bar(3) to Leg(2) using Bolts(A), Spring Washers(B) and Washers(D) with Allen Key(E).

**Only Loosely tighten at this stage.**

Repeat the same process with the another Leg.

### Step 2

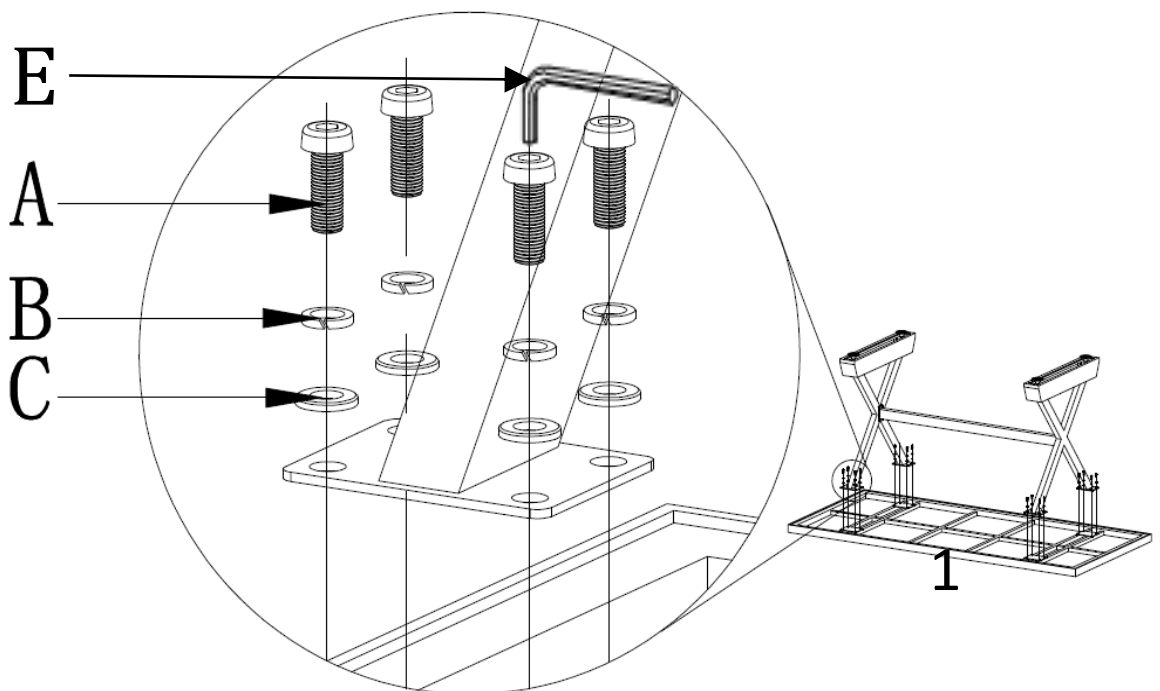

With assistance of your partner, carefully place the Table Top(1) face down on a clean, non-marring surface.

With assistance from your adult partner, pick up and turn the pre-assembled Leg Frame from Step 1, 180° degrees. Align the mounting points of the Legs to the mounting points on the underside of Table Top(1).

Attach the Legs to the Table Top(1) using Bolts(A), Spring Washers(B) and Washers(C) with Allen Key(E) as shown above. **Tighten Bolts in a sequential manner.**

Turn Table over to assess for evenness. If there is wobbles, you can achieve with either one of the following steps :

1 ) release the bolts attaching the Legs to the Table Top and re-tighten in a slower sequential method OR

2 ) in mild wobbles, adjust the Adjustable Gliders to achieve evenness.

**Where necessary, turn Table right side up and in a sequential manner, proceed to tighten all bolts at the underside of the Table and at the 'X-point' of the legs.**

**DO NOT fully tighten a BOLT in one go and then move on to the next. Rather, In a sequential manner, gradually tighten each Bolt until all bolts are evenly secured. This methodology will ensure maximum evenness once all Bolts are fully tightened.**

### Step 3

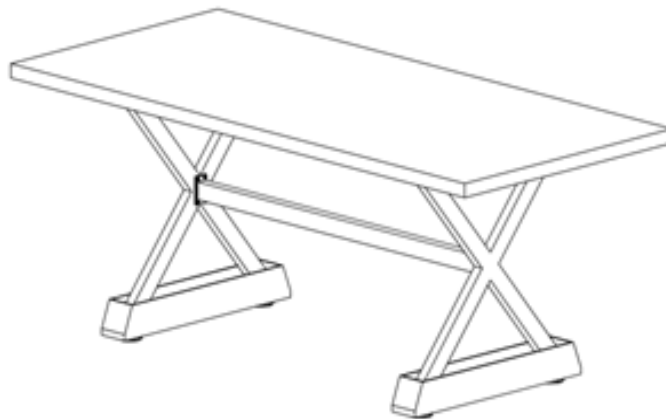

With assistance from your adult partner, stand the Table up.  
Inspect and make sure all parts are connected and fully secured into position.  
Your Table is now ready for use.

## Care & Maintenance



- Do not put hot items directly on furniture surface.



- Do not clean furniture with harsh cleansers or polish.



- To obtain the longest lifespan of your outdoor products, minimizing exposure to direct sunlight is recommended.



- Children should not climb or jump on the furniture.



- Do not write on furniture without a padded barrier to protect the surface.



- To obtain the longest lifespan of your outdoor products, avoid extended and lengthy exposure to rain, snow, and direct sunshine. Whenever possible cover the product and /or place under patio or awnings.



- Not for commercial use. For residential use only .



- Stains may be removed with mild soap solution and damp cloth.



- Dust and pick-up spills using a clean, non-colored, lint-free cloth .