



VESSEL TOP INSTALLATION GUIDE

INSTALLATION INSTRUCTIONS

Caution: Read all instructions carefully before starting the installation. Sink style, shape, cutout on top and vanity may vary from the pictures below. For instructional purposes only.

Step 1:

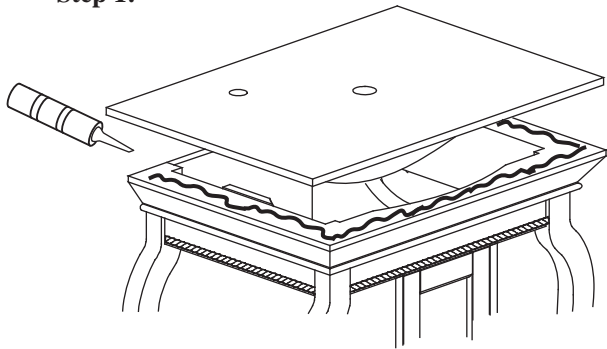

Apply bead of quality sealant evenly along the top of the vanity

Step 2:

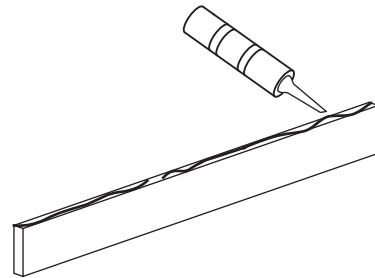

Apply silicone sealant evenly along the bottom of back splash and wall

Step 3:

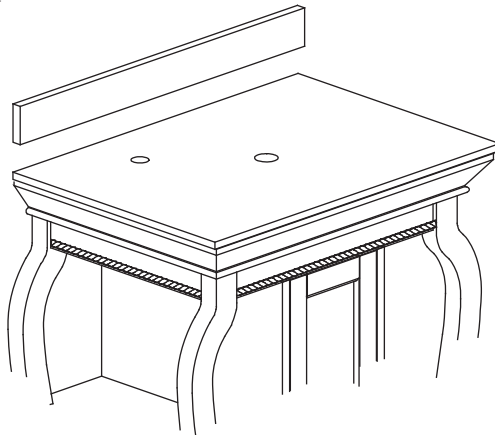

Place the bottom side of back splash with sealant onto the countertop and check alignment of back splash. Adjust the leg levelers as needed

Step 4:

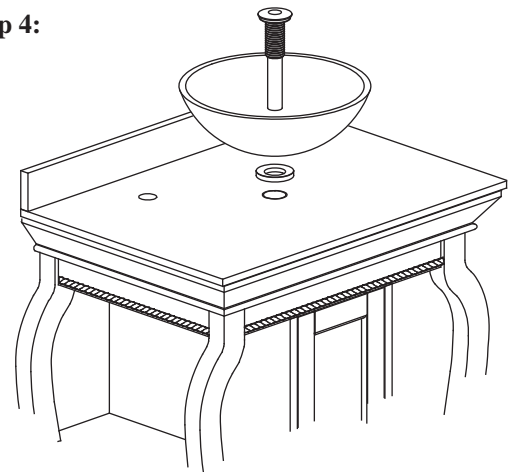

Carefully, install the vessel sink, mounting ring and drain. See manufacturers instructions



IMPORTANT CONSUMER INFORMATION

CARE AND CLEANING

For best results in caring for your stone top, we suggest:

- Always wipe off spills immediately.
- Seal the stone top regularly with a good quality stone sealer.
- Never use strong / abrasive cleaner. Always test your cleaning solution on unnoticeable areas before applying to the entire surface.
- Wipe surfaces clean, immediately after applying cleaner.
- Do not allow cleaner to sit or soak. Never let cleaners sit on the surface of the stone for long periods of time.
- Use a soft, dampened sponge and cloth. Never use an abrasive material such as brush or scouring pad to clean surfaces. They will scratch the surface of the stone top and lavatory.
- Always rinse and wipe clean the fixtures to prevent soap buildup.

Clean the **metal surface** of your JSG *Oceana* furniture with mild soap and warm water. Rinse and dry with a dry towel to restore luster. (Use an old toothbrush to get dirt in difficult to reach places). Polish the **wood surface** of your JSG *Oceana* furniture with wood furniture polish. Clean the **mirror or glass surface** of your JSG *Oceana* furniture with warm water used with a soft cloth. If you use a commercial glass cleaner, choose one that does not contain ammonia or vinegar. Do not spray cleaner directly on the glass or mirror surface. Apply the cleaner to a soft cloth and use that to wipe the glass or mirror. Make sure no commercial product comes in contact with the mirror backing as it can cause damage to the mirror. Avoid products that contain abrasives or harsh chemicals that can scratch and discolor your furniture.

CALL US FOR HELP—724.523.5567

First review the installation instructions to ensure correct installation. If you are unable to correct the problem, call our Customer Service Department for direct help. Dial 724.523.5567 from within the USA.

LIMITED ONE-YEAR WARRANTY

JSG *Oceana* Furniture is warranted free of manufacturing defects. JSG *Oceana* will, at its election, repair, replace, or make appropriate adjustment where JSG *Oceana* inspection discloses any such defects occurring in normal usage within one year after installation. **JSG *Oceana* is not responsible for installation or removal costs.**

Proof of purchase requires the original sales receipt from the original consumer purchaser and must accompany all warranty claims. To obtain warranty service, contact JSG *Oceana* either through your dealer or Plumbing Contractor, or by writing JSG *Oceana*, Attn: Customer Service Department, 215 N. Fourth Street, P.O. Box 99, Jeannette, PA, 15644.

Implied warranties, including that of merchantability or fitness for a particular purpose, are expressly limited in duration to the duration of this warranty. JSG *Oceana* disclaims any liability for special, incidental or consequential damages.

Some states do not allow limitations on how long an implied warranty lasts or the exclusion or limitation of special, incidental, or consequential damages, so these limitations and exclusions may not apply to you. This warranty gives you specific legal rights. You may also have other rights which vary from state to state.

This limited warranty provides specific legal rights as they apply within the USA, and other rights may be available, but may vary from country to country.

This is our exclusive written warranty.
JSG *Oceana*, JEANNETTE 15644