

KEY #	PART NO.	DESCRIPTION	QTY.
1	4844	HANDLEBAR FOAMED DUAL STYLE	1
2	10626	ENGINE 51CC VPR CAT HNDLBR MNT	1
3	4822	ASSEMBLY TRIGGER LONG THROW	2
4	4827	BOLT 10-24 X 1/2 PPHMS GR5 ZN	2
5	90148	BOLT 10-24 X 3/4 HH GR5 BLK ZN	4
6	3004119	TRANSMISSION ASSEMBLY	1
7	10473	CABLE ASSEMBLY TWO INTO ONE	1
8	75300*	KIT TOP CASTING	1
9	3004100	CLUTCH DRUM	1
10	8922	BALL BEARING R12 DOUBLE LIP	3
11	9814	GEAR 7T PINION THREADED, 5/8" THREAD	1
12	8924	SNAP RING	3
13	8915	DOWEL PIN STEEL 1/4" X 1/2"	2

KEY #	PART NO.	DESCRIPTION	QTY.
14	8912	GEAR 44T 3/4" HOLE	1
15	8919	GASKET	1
16	8923	BALL BEARING R10	2
17	8914	GEAR 48T HARD	1
18	75600**	KIT LOWER CASTING	1
19	8913	SHAFT OUTPUT 7/8"	1
20	8931F	BOLT 1/4-20 X 2 SHCS F-T	4
21	8929	BOLT 1/4-20 X 1-1/2 SHCS	2
22	9214A	GEAR 10T CLUSTER PINION HT	1
23	11468	GREASE EP2 MOLY	1

* The top casting kit (P/N: 75300) includes a gasket (P/N: 8919). It also includes a shim (P/N: 3004149) that is not needed for the Dually.

** The lower casting kit (P/N: 75600) includes the powerhead transmission gasket (P/N: 8919), and ball bearings (P/Ns: 8922, 8923).

AUGER PARTS EXPLOSIONS

EA2F, EA3F

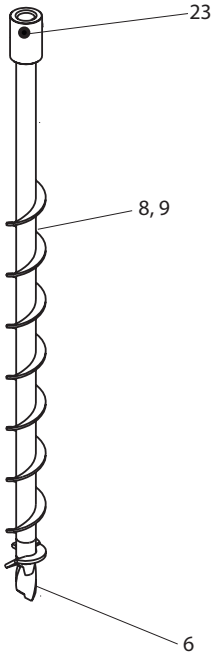

EA4F

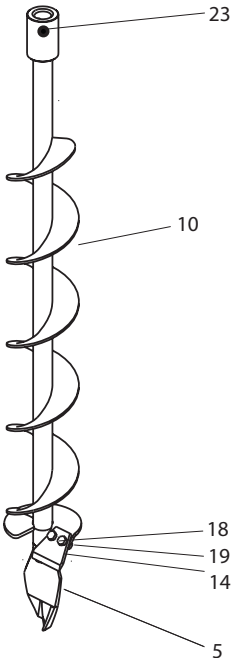

EA6F

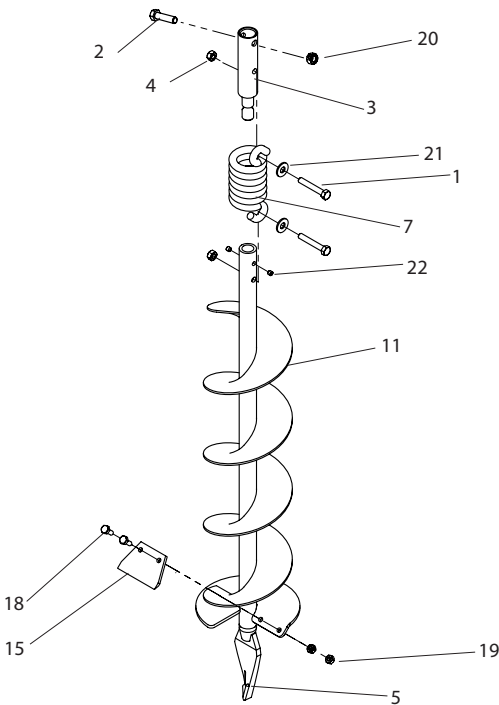

EA8F

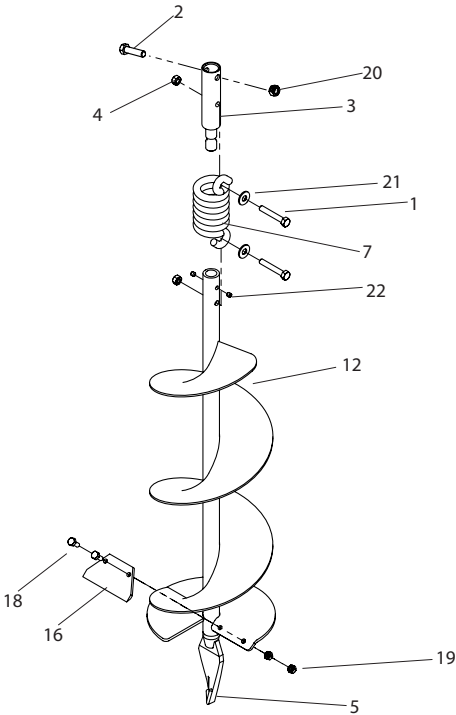

EA10F

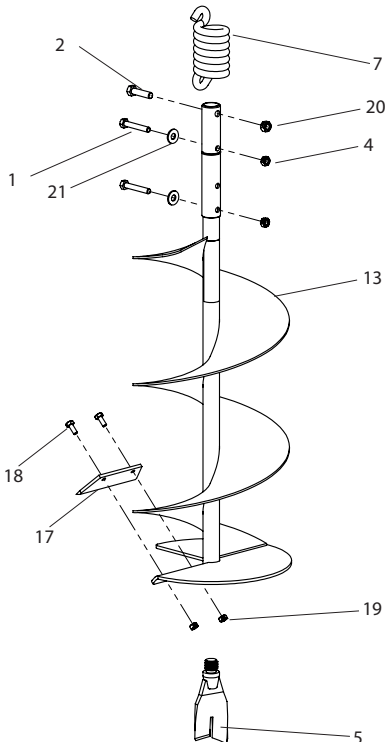

EXT12

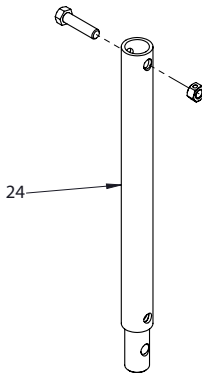

EXT18

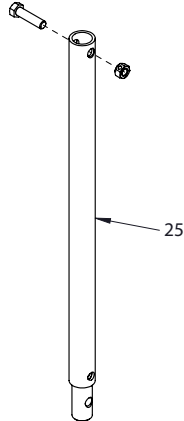

AUGER PARTS LIST

KEY NO.	PART NO.	DESCRIPTION	QTY.
1	1423	BOLT-HHCS, 5/16-18 X 2", GRADE 5 (auger shock spring)	2
2	1433	BOLT-HHCS, 3/8-16 X 1-1/2" (auger to powerhead)	2
3	53684	SHOCK TOP 1-PC (used on 6" and 8" earth augers)	1
4	60G56	NUT-HEX 2-WAY REVERSIBLE LOCK-NUT, 5/16-18	2
5	8958HD	FISHTAIL POINT (used on 4" or larger earth auger)	1
6	8970	EARTH POINT (used on 2" & 3" earth auger)	1
7	8980	SHOCK SPRING (Used on 6" and larger earth augers)	1
8	EA2F	EARTH AUGER, 2" W/FISHTAIL POINT	1
9	EA3F	EARTH AUGER, 3" W/FISHTAIL POINT	1
10	EA4F	EARTH AUGER, 4" W/FISHTAIL POINT	1
11	EA6F	EARTH AUGER, 6" W/FISHTAIL POINT	1
12	EA8F	EARTH AUGER, 8" W/FISHTAIL POINT	1
13	EA10F	EARTH AUGER, 10" W/FISHTAIL POINT	1
14	EB4	EARTH BLADE, 4" (includes EBOLT & ENUT)	1
15	EB6	EARTH BLADE, 6" (includes EBOLT & ENUT)	1
16	EB8	EARTH BLADE, 8" (includes EBOLT & ENUT)	1
17	EB10	EARTH BLADE, 10" (includes EBOLT & ENUT)	1
18	EBOLT	BOLT-HEX, 1/4-28 X 5/8", GRADE 5 (earth blade to auger)	2
19	ENUT	NUT-NYLOC, 1/4-28	2
20	2104	NUT HEX LOCKING, 3/8-16	2

KEY NO.	PART NO.	DESCRIPTION	QTY.
21	WF516	WASHER-FLAT, 5/16"	2
22	715	SET SCREW 1/4-20 X 1/4 SCPC BLK OXIDED	2
23	8955	BOLT 3/8-16 X 1-1/4 SHCS	1
24	EXT12	DEPTH EXTENSION, 12"	1
25	EXT18	DEPTH EXTENSION, 18"	1
ITEMS NOT SHOWN			
--	EB6HD	HEAVY DUTY EARTH BLADE, 6" (includes EBOLT & ENUT)	1
--	EB8HD	HEAVY DUTY EARTH BLADE, 8" (includes EBOLT & ENUT)	1
--	EB-10HD	HEAVY DUTY EARTH BLADE, 10" (includes EBOLT & ENUT)	1

DUALLY ENGINE PARTS EXPLOSION

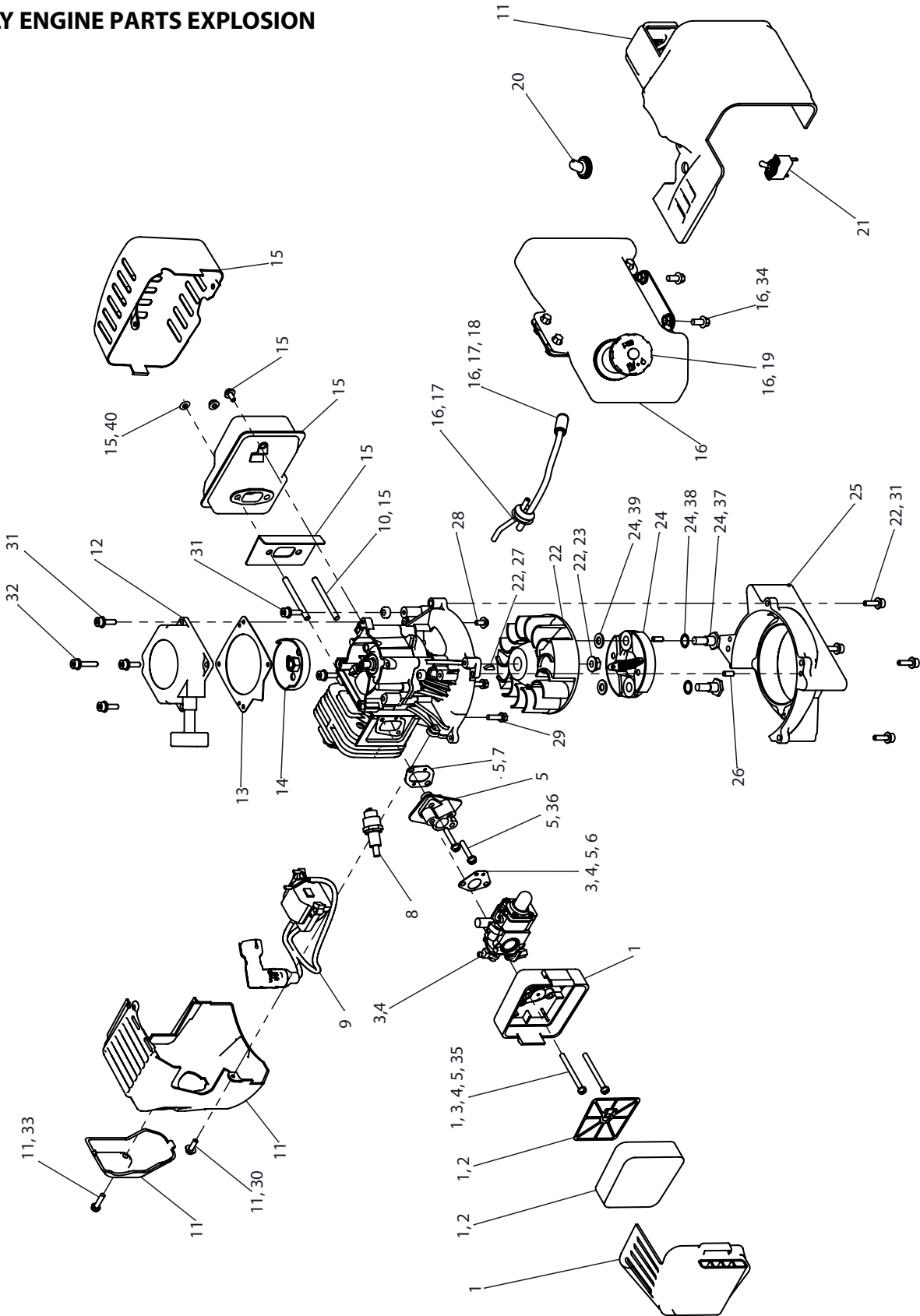

DUALLY ENGINE PARTS LIST

KEY NO.	PART NO.	DESCRIPTION	QTY.
1	11350	KIT AIR FILTER ASSY SUMMER 2-CYCLE VIPER	1
2	11349	KIT FILTER BLOCK 2-CYCLE VIPER	1
3	11334	KIT CARBURETOR REPLACE	1
4	3004114	KIT CARBURETOR REPAIR 43CC/51CC/71CC	1
5	11205	KIT INTAKE MANIFOLD	1
6	300479	GASKET CARBURETOR 43/51/71 VIPER ENGINE	1
7	300476	GASKET INTAKE VIPER ENG	1
8	BM6A	SPARK PLUG	1
9	300469	IGNITION COIL	1
10	300493	STUD BOLT M6X62MM	2
11	11333	KIT ENGINE AND GAS TANK SHROUDS	1
12	300430	RECOIL ASSEMBLY W/STANDARD HANDLE	1
13	300429	SPACER RECOIL PLATE 2-CYCLE VIPER	1
14	300491	CUP RECOIL CLUTCH 2-CYCLE VIPER	1
15	11197	KIT MUFFLER STRAIGHT EJECTION	1
16	10683	KIT COMPLETE GAS TANK THREE TAB	1
17	3004105	KIT FUEL LINES	1
18	3004103	FUEL FILTER	1
19	300401	GAS CAP VIPER ENGINE SCREW VENT	1
20	10929	COVER TOGGLE SWITCH	1
21	300524	SWITCH TOGGLE BARREL M12	1

KEY NO.	PART NO.	DESCRIPTION	QTY.
22	11209	KIT FLYWHEEL	1
23	300337	NUT M8	1
24	11235	KIT CLUTCH VIPER	1
25	3004110	MOUNT RING AND SHROUD 43/51.7CC HP	1
26	300467	PIN LOCATING VIPER ENG	2
27	300338	KEY	1
28	3250	BOLT M5 X 0.8 X 12 PPHMS GR 8.8 ZN	2
29	300335	BOLT M5 X 20 HH-PCS	2
30	10887	BOLT M5 X 0.8 MM X 16 MM PH W/ WASHER	1
31	10809	BOLT M5 X 20 SHCS GR 8.8 ZN	9
32	11169	BOLT M5 X 28	1
33	300439	BOLT M5 X 20	1
34	300336	BOLT M6 X 1 X 10MM HHF	6
35	300456	BOLT M5 X 50MM W/ WASHER HP ENGINE	2
36	300438	BOLT M5 X 25MM WASHER HD	2
37	300450	BOLT SHOULDER CLUTCH ROTOR	2
38	300449	WASHER M8 SPRING ROTOR	2
39	300462	WASHER M8	2
40	300492	NUT M6 X 1.0 HF GR8.8 YL ZN	2