

**EVERBILT**™

Item # 1004181632  
Model # EBAU25-PCP

## USE AND CARE GUIDE

### 1/4 HP SUBMERSIBLE POOL COVER PUMP

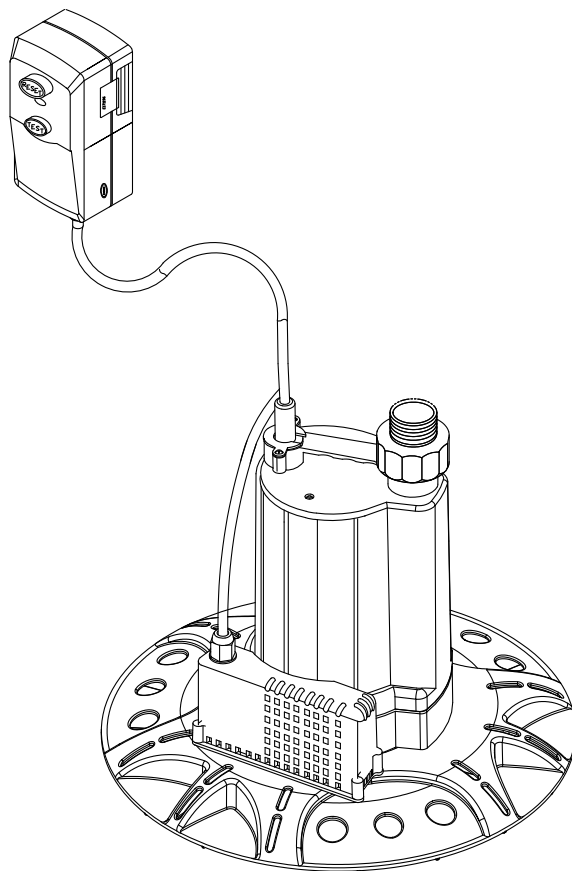

Questions, problems, missing parts? Before returning to the store,  
call Everbilt Customer Service  
8 a.m. - 5 p.m., EST, Monday-Friday

**1-844-251-7446**

**HOMEDEPOT.COM**

---

#### **THANK YOU**

*We appreciate the trust and confidence you have placed in Everbilt through the purchase of this 1/4 HP submersible pool cover pump. We strive to continually create quality products designed to enhance your home. Visit us online to see our full line of products available for your home improvement needs. Thank you for choosing Everbilt!*

# Table of Contents

- Table of Contents ..... 2
- Performance ..... 2
- Safety Information ..... 2
- Warranty ..... 3
- Pre-installation ..... 4
  - Application ..... 4
  - Tools Required ..... 4

- Package Contents ..... 4
- Specifications ..... 5
- Installation ..... 5
- Operation ..... 7
- Care and Cleaning ..... 8
- Troubleshooting ..... 9

# Performance

SKU	HP	*GPM of Water @ Total Feet of Lift					Max Lift
		0 ft.	5 ft.	10 ft.	15 ft.	20 ft.	
1004181632	1/4 HP	24	22	19	14	4	21.5 ft.

\*Performance at 1-1/4 in. discharge. Garden hose usage will reduce flow rates.

 **NOTE:** Above performances are at 1-1/4 in. discharge hose. Using a smaller diameter garden hose will reduce flow rates. Also, keep hose length as short as possible, as longer hoses will reduce flow rates.

# Safety Information

 **DANGER:** Do not pump flammable or explosive liquids such as gasoline, oil, kerosene, ethanol, etc. Do not use in the presence of flammable or explosive vapors. Using this pump with or near flammable liquids can cause explosion or fire, resulting in serious personal injury and/or property damage.

 **DANGER:** Always disconnect the pump from its power source before servicing.

 **DANGER:** RISK OF ELECTRICAL SHOCK. This pump is supplied with a grounding conductor and grounding-type attachment plug and a built in Ground Fault Circuit Interruptor (GFCI). To reduce the risk of electrical shock, be certain that it is connected only to a properly grounded receptacle.

 **DANGER:** Do not handle the pump with wet hands or when standing on a wet or damp surface, or standing in water, before disconnecting the power.

 **DANGER:** Never touch any electrical device, including this pump, when it is touching water, in water, or even in a moist environment. Always unplug (disconnect the electricity) when working on or installing the unit.

 **DANGER:** Never use this pump in or around a swimming pool when people are inside the swimming pool.

 **WARNING:** When possible, try not to connect the included GFCI plug to an existing GFCI outlet, as it may cause nuisance tripping. If the GFCI plug does not fit into the outlet box, an extension cord may be used. Do not let the extension cord end fall in water or get wet. The GFCI plug will not protect against shock hazards that occur in the extension cord.

 **WARNING:** Do not leave the pump plugged in and left outside when freezing temperatures are expected, as the pump may be damaged.

 **WARNING:** Failure to comply with the instruction and designed operation of this unit may void the warranty. ATTEMPTING TO USE A DAMAGED PUMP can result in property damage, serious personal injury, and/or death.

 **WARNING:** Do not disassemble the motor housing. The motor has NO repairable internal parts, and disassembling may cause dangerous electrical wiring issues and will void warranty.

## Safety Information (continued)



**WARNING:** This unit is designed only for use on 115 volts (single phase), 60 Hz, and is equipped with an approved 3-conductor cord and 3-prong grounded plug. **DO NOT REMOVE THE GROUND PIN UNDER ANY CIRCUMSTANCES.** The 3-prong plug must be directly inserted into a properly installed and grounded 3-prong, grounding-type receptacle. Do not use this pump with a 2-prong wall outlet. Replace the 2-prong outlet with a properly grounded 3-prong receptacle installed in accordance with the National Electrical Code and local codes and ordinances. All wiring should be performed by a qualified electrician.



**WARNING:** Do not use the power cord or discharge hose to carry or handle the pump. Doing so may cause damage to the power cord or discharge hose. Use the handle supplied with the pump.



**WARNING:** Secure the discharge line before starting the pump. An unsecured discharge line will whip, possibly causing personal injury or property damage.



**WARNING:** Release all pressure and drain all water from the system before servicing any component.



**WARNING:** Wear safety goggles at all times when working with pumps.



**WARNING:** When possible, connect the pump **DIRECTLY** to a grounded outlet. Extension cords may not deliver sufficient voltage to the pump motor. Extension cords present a life-threatening safety hazard if the insulation becomes damaged or the connection ends fall into water. If using 25 ft. extension cord, use 16-gauge wire or thicker.



**WARNING:** Protect the electrical cord from sharp objects, hot surfaces, oil, and chemicals. Avoid kinking the cord. Do not use damaged or worn cords.



**WARNING:** Ensure that the electrical circuit to the pump is protected by a 15-amp minimum fuse or circuit breaker.



**WARNING:** Try to keep the pump as straight as possible. Do not suspend the pump by the discharge hose or power cord. Keep the pump intake clear.



**CAUTION:** Periodically inspect the pump and system components to ensure the pump intake is free of mud, sand, and debris. Disconnect the pump from the power supply before inspecting.



**CAUTION:** Know the pump and its applications, limitations, and potential hazards.



**CAUTION:** Follow all electrical and safety codes, particularly the National Electrical Code (NEC) and in the workplace, the Occupational Safety and Health Act (OSHA).



**IMPORTANT:** Ensure the electrical power source is adequate for the requirements of the pump.



**IMPORTANT:** For safety, this pump motor has an automatic resetting thermal protector that automatically turns the pump off if it becomes too hot. **Overuse of this feature will damage the pump and will void the warranty.**



**IMPORTANT:** This pump is made of high-strength, corrosion-resistant materials. It will provide trouble-free service for many years when properly used and maintained. However, inadequate electrical power to the pump, or blockage by ice, dirt, or debris may cause the pump to fail. Please carefully read the manual and follow the instructions regarding common pump problems and remedies.



**IMPORTANT:** This pump is not intended for use in sewage or septic systems. Doing so will void warranty.



**IMPORTANT:** This pump is not intended to be used as a permanently installed sump pump. Use as a sump pump will void the warranty.

## Warranty

The manufacturer warrants to the original purchaser that it will be free from any defect in materials and/or workmanship for one (1) year from date of purchase. This limited warranty is extended **ONLY** to the original purchaser, and only covers products purchased as new. If during this one-year period, the original purchaser experiences a defect which is covered by this limited warranty, it will be repaired or replaced (at manufacturer's sole option) at no cost to the purchaser. Defective parts will be repaired or replaced with new or factory rebuilt parts at the manufacturers' sole option.

The purchaser must pay all labor and shipping charges necessary to replace the product covered by this warranty.

## Warranty (continued)

This limited warranty is in lieu of any other warranties, express or implied, including any implied warranty of merchantability or fitness for a particular purpose, or otherwise, and of any other obligations or liability on the seller's part. This limited warranty does not cover non-defect damage, damage caused by improper installation, or care (including but not limited to abuse, misuse, failure to provide reasonable and necessary maintenance, or dismantling or for reinstalling a repaired or replaced product or component).

Under no circumstances shall the manufacturer be liable for consequential, incidental, or special damages arising in connection with the use of, or inability to use this product. In no event shall manufacturer's liability for breach of warranty, breach of contract, negligence or strict liability exceed the cost of the product covered hereby. No person is authorized to assume for us any liability in connection with the sale of this product. Some states do not allow limitations on implied warranties and the exclusion or limitation of consequential, incidental, or special damages, so the above limitation or exclusion may not apply to you. This limited warranty gives you specific legal rights and you may also have other rights which vary from state to state.

Contact the Customer Service Team at 1-844-251-7446 or visit [HOMEDEPOT.COM](http://HOMEDEPOT.COM).

## Pre-installation

### APPLICATION

- This submersible utility pump is designed for use on swimming pool covers. Its automatic design allows the pump to be left plugged in without monitoring. The pump will shut off by itself once the water has been removed. Do not leave the pump plugged in and outside when freezing temperatures are expected, as it will damage the pump.
- If the pool cover base is removed, the pump is also designed for general water removal applications. It can automatically drain or remove water from the following: flooded areas, window wells, low spots in yards or other areas that collect water, clogged sinks, water basins, boats, stock tanks, etc.
- This pump has not been tested or approved for use in swimming pools or in salt-water marine areas.
  - It is designed to pump rain water from pool covers, not chlorinated pool water.
- This pump should not be used as a replacement for a sump pump.
- It is not engineered to be run continuously as a "fountain" or "waterfall" pump, or in any other water re-circulation process.

### TOOLS REQUIRED



Phillips  
screwdriver

### PACKAGE CONTENTS

Part	Description
A	Pump
B	Pool Cover Base
C	3/4 in. Garden Hose Adapter
D	Pool Cover Base Screws

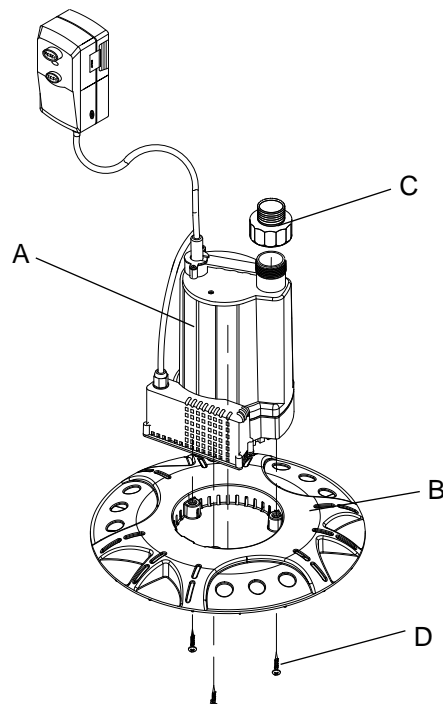

# Pre-installation (continued)

## SPECIFICATIONS

Power Supply Required	115V, 60 HZ
Liquid Temp. Range	32°F to 95°F (0°-35°C)
Individual branch circuit required	15 Amp Minimum
Discharge Connection	1-1/4 in. Male NPT or 3/4 in. garden hose connection
Discharge Hose Needed	1-1/4 in. Flexible Discharge Hose or 3/4 in. garden hose
Power Cord	SJTW, 18AWG/3C, 25 ft.

## Installation

### 1 Attaching the pool cover base to the pump

- Line up the pump (A) on the pool cover base (B).
- There are three (3) feet on the bottom of the pump (A) that must sit in the holes of the pool cover base (B).
- Once the pump (A) is in place, hold the pump (A) and pool cover base (B) together, and turn over.
- Using the three included Phillip head screws (D), attach the pool cover base (B) to the pump (A).



**NOTE:** Periodically remove this base to clear any debris that may collect in the base. A clear path for the water will allow the pump to perform its best.

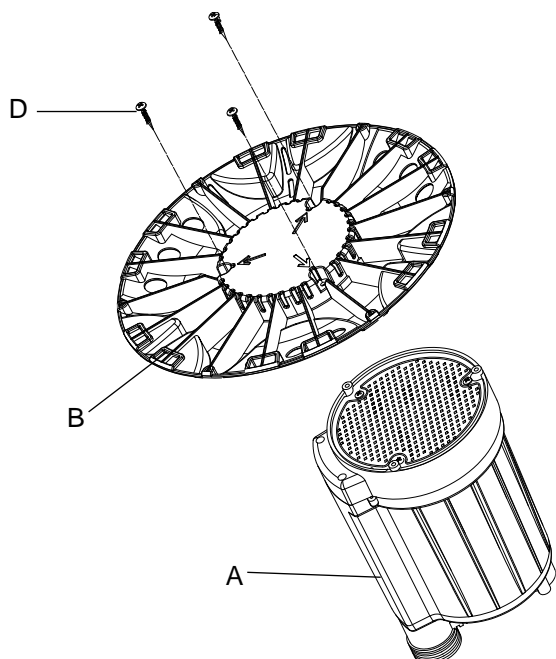

### 2 Connecting the adapter

- Attach the garden hose adapter (C) to the pump (A) discharge.



**NOTE:** For greater flow rate, use a 1-1/4 in. flexible discharge hose, and keep hose lengths as short as possible (50 ft. or less). Narrow and long discharge hoses restrict the flow.

A 1-1/4 in. female threaded coupler may need to be purchased separately for connection with the flexible discharge hose.

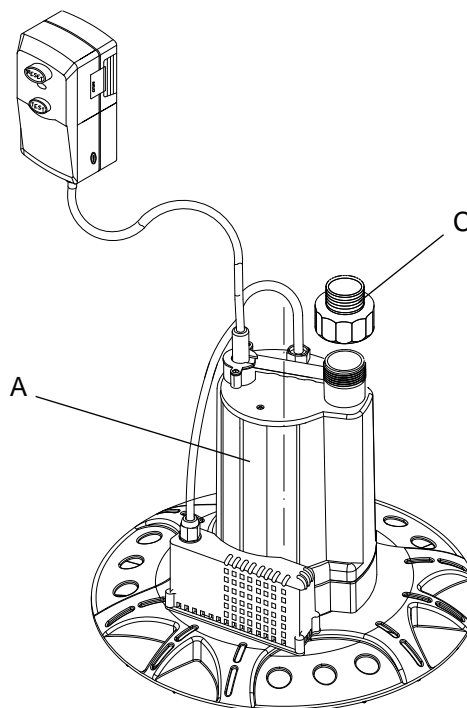

## Installation (continued)

### 3 Connecting the discharge hose

- Attach a 3/4 in. garden hose (not included) to the adapter (C).



**NOTE:** Be sure the 3/4 in. garden hose connector has a rubber gasket to minimize water leaks.



**WARNING:** Secure the discharge hose before plugging in the pump. An unsecured discharge hose may “whip”, possibly causing personal injury and/or property damage.

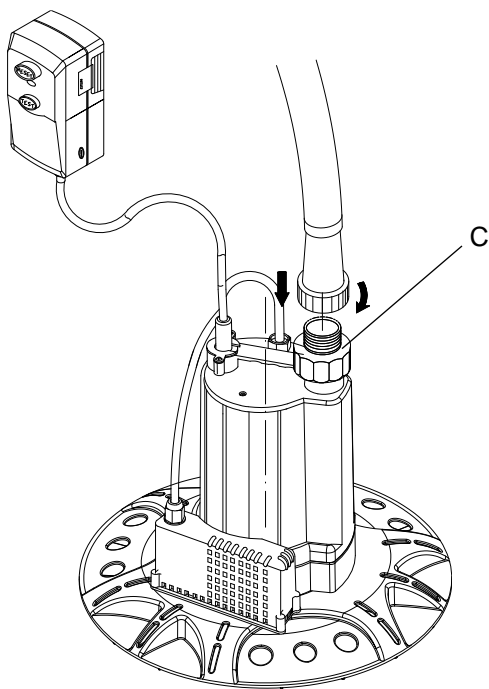

### 4 Placing the pump on the pool cover

- Place the pump (A) on the pool cover.
- Using a pole, broom, or rake, push the pump (A) to the desired location on the pool cover.



**NOTE:** Depending on your pool cover, the pump may tip. In order for the float switch to operate properly, try to place the pump in a location that allows the pump to sit as straight as possible.



**NOTE:** Do not coil or kink the hose.

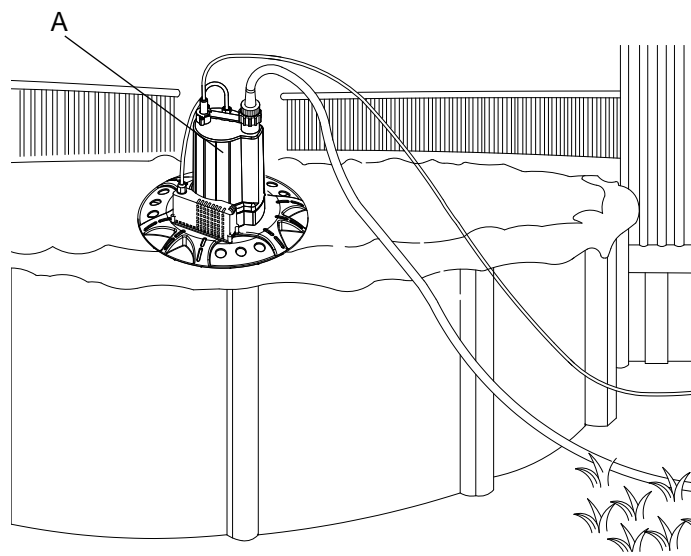

# Operation

## Operating the pump

- Plug the pump (A) into a properly grounded outlet.
  - The pump (A) is equipped with a Ground Fault Circuit Interrupter (GFCI) plug. If the pump is not running when it should be, check this plug to ensure it has not tripped. If it has tripped, press the button on the plug to reset. If the pump continuously trips, try plugging the pump into a different outlet.
  - If extension cords are used, make sure the extension cord ends cannot get wet. The GFCI plug will not protect against shock hazards that occur in the extension cord.
- When there is at least 2-1/4 in. of water around the pump, the float switch will be raised, turning the pump on.
- When water is pumped down to approximately 11/16 in., the pump will run for an additional 30-60 and then shut off.
- The pump will turn on again when water rises to 2-1/4 in.



**WARNING:** Do not allow the plug to fall in the water and do not stand in the water or on a damp surface while the pump is plugged in. Do not handle the plugged-in pump with wet hands.

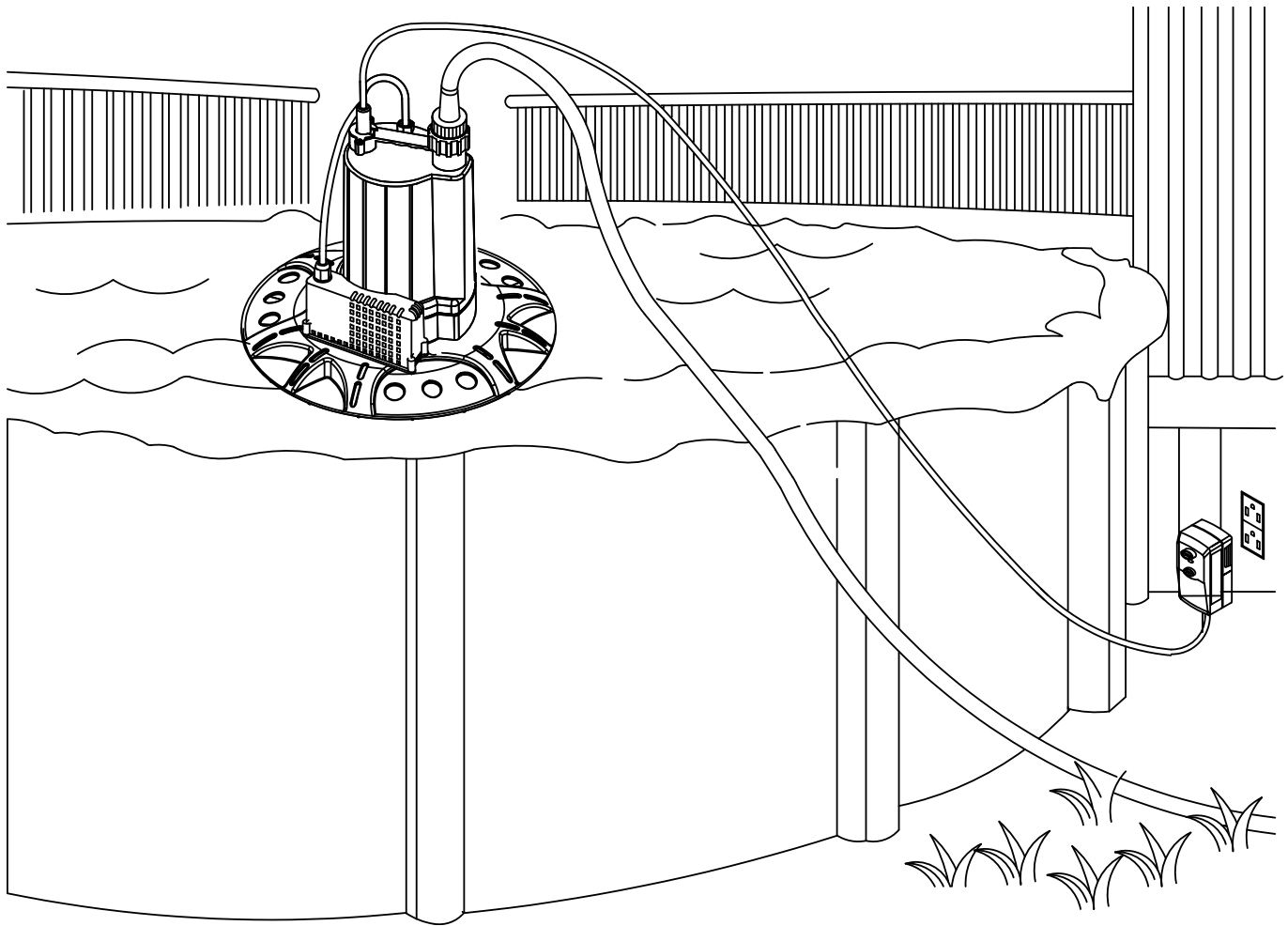

**NOTE:** The float switch is located in the cage on the side of the pump. Keep this cage clean so the float switch can operate properly.

# Care and Cleaning

## Do

- When the power is disconnected, inspect the pool cover base and the pump intake screen (bottom of pump) and remove all debris, then plug the pump back into the grounded outlet.

### To clean a pump clogged with debris:

- Unplug the pump from electrical power.
- Remove the screws and pool cover base from the pump.
- Remove the screws and screen from the bottom of the pump.
- Remove the screws, volute, and seal gasket from the pump.
- Clean the debris from the impeller and pool cover base. Reassemble.
- If debris is preventing the float switch from operating properly, remove any debris from the float switch cage on the side of the pump. The bottom portion of this cage can be removed for further cleaning.
- Contact the Customer Service Team at 1-844-251-7446 or visit [HOMEDEPOT.COM](http://HOMEDEPOT.COM) for any replacement parts.

## Do Not

- Do not disassemble the motor housing. This motor has NO repairable internal parts, and disassembly may cause leakage or dangerous electrical wiring issues.
- Do not lift the pump by the power cord.

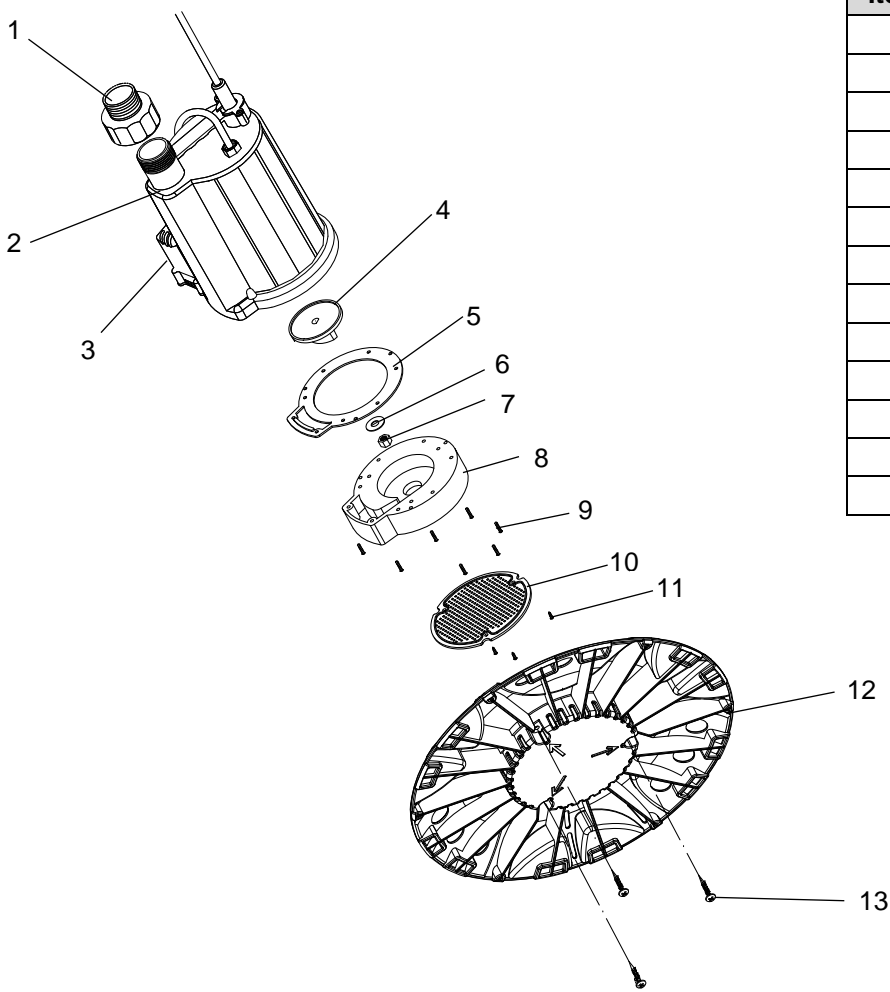

Item	Description	Qty
1	3/4 in. Garden hose adapter	1
2	Pump casing and motor	1
3	Float switch	1
4	Impeller	1
5	Seal gasket	1
6	Washer	1
7	Nut	1
8	Volute	1
9	Volute screws	8
10	Screen	1
11	Screen screws	3
12	Pool cover base	1
13	Pool cover base screws	3



# Troubleshooting



**CAUTION:** SHUT OFF POWER TO THE PUMP.

Problem	Possible Cause	Corrective Action
The motor runs but no water is discharged or flow rate is lower than expected.	The intake screen or impeller is blocked.	Clean the intake screen and impeller.
	There is an airlock in the discharge.	Clean the airlock release feature (see label on base of pump). If not blocked, slightly loosen the hose while pump is running to release airlock.
	The discharge hose is kinked, bent sharply or coiled.	Straighten the hose.
	The discharge hose/pipe goes up too high.	Every pump has a maximum "head" capability, which is the highest it can lift water. Do not route the discharge hose/pipe higher than 21.5 ft.
	The hose diameter is too narrow or the hose is too long.	Use at least a 3/4 in. diameter hose and use a hose that is shorter than 50 ft. in length.
	The extension cord is not providing sufficient power.	Use a shorter, heavier gauge extension cord, or when possible, plug the pump directly into the power source.
	The impeller is broken.	Call 1-844-251-7446 for a replacement.
The motor does not run or is humming. The pump not running.	The water is not high enough to activate the float switch.	Water must be at least 1-1/2 in. high to activate the float switch. Place pump in an area with more water to activate the float switch.
	The float switch is blocked by debris.	Clean out the float switch cage so it can operate freely.
	The impeller is stuck or jammed with debris.	Inspect the impeller area for any debris that may have entered. Remove as needed. Make sure impeller rotates freely.
	The pump is not getting any power.	<ul style="list-style-type: none"> <li><input type="checkbox"/> Check the outlet where the pump is plugged in. Make sure it has power. If no power, check your home's fuse or circuit breaker panel and repair as needed.</li> <li><input type="checkbox"/> Ensure the pump's plug is also making good contact in the outlet.</li> <li><input type="checkbox"/> Check to see if the GFCI outlet needs to be reset.</li> </ul>
	The pump has overheated (thermal overload).	Unplug the power and wait for 30 minutes, then plug the power cord back in the outlet.
	The liquid temperature is below 32°F or above 95°F.	Do not operate the pump in temperatures as indicated.
	The motor has failed.	If all items above check out OK, the motor has failed. Replace the pump.



Questions, problems, missing parts? Before returning to the store,  
call Everbilt Customer Service  
8 a.m. - 5 p.m., EST, Monday-Friday

**1-844-251-7446**

**HOMEDEPOT.COM**

Retain this manual for future use.