

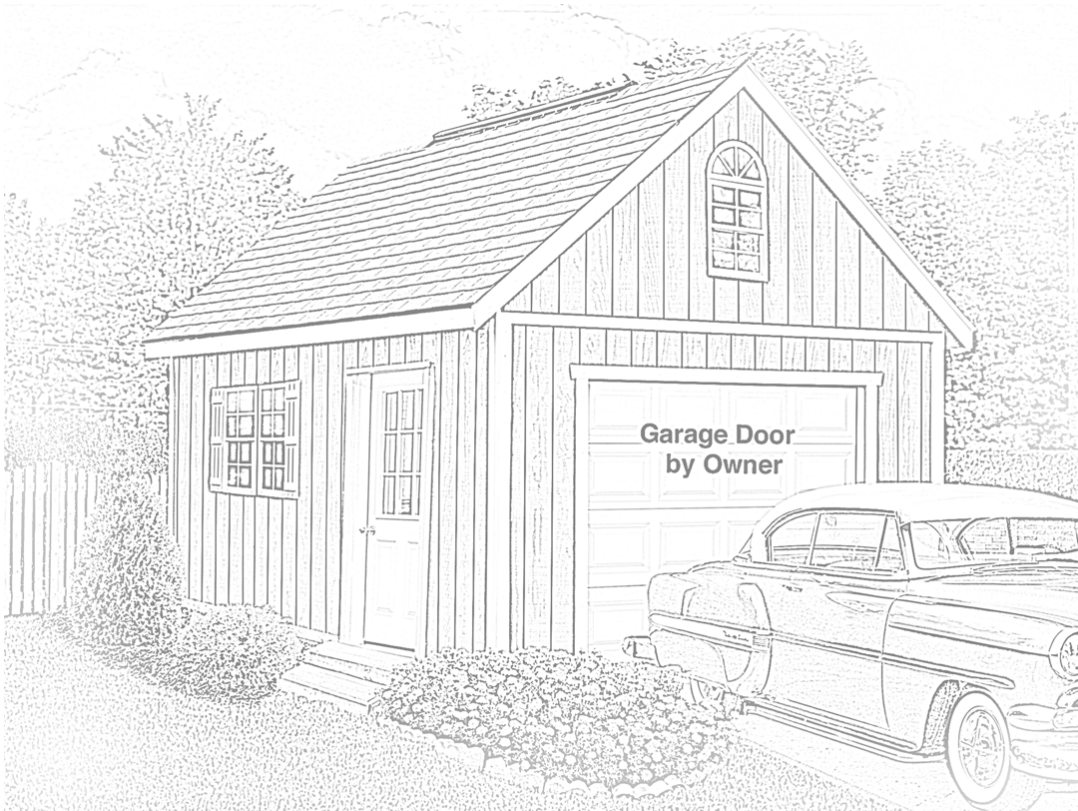

Best Barns USA Assembly Book

Revised March 7, 2017



the Glenwood

**Building Size
12' x 20'**

Manufactured by Reynolds Building Systems, Inc.

205 Arlington Drive - Greenville, PA 16125

This manual is copyrighted. Under the copyright laws, this manual may not be copied, in whole or in part, without consent from Reynolds Building Systems, Inc. © Copyright 2013

IMPORTANT INFORMATION ABOUT YOUR SHED KIT

This manual will show the assembly for the Glenwood building kit. See back page for the breakdown of this material. **If you received duplicate books, use the one with the latest revision date. The foundation is 12'-0" x 19'-9". Do Not make the foundation larger.**

Read the instructions before starting the assembly of the building. If you have any questions about assembling the kit, call 800-245-1577. Business hours (8:00-5:00 ET) Monday thru Friday. After business hours call 724-866-HELP (4357) or email to help@barnkits.com.

The siding, roof sheathing, long framing material and optional floor *if ordered*, will be delivered by a local supplier. The breakdown of this material is listed on the back page. Check to see if you received the correct amount of material before the driver leaves and note any shortage.

The 12' material was shipped in (4) four cardboard packages. The shorter lumber is shipped on a small pallet. Stacking the boards, according to size, will make them easier to find when needed. **Do Not** discard any material, *no matter how small*, until your building is complete.

Paint the bottom edges of the siding around the perimeter of the building. Keep dirt, grass, mulch, snow and similar substances away from the lower part of the siding. The siding manufacturers generally recommend 8" or more of clear space.

Before you begin construction, study this assembly manual. Also, obtain a building permit and check all pertinent building code regulations.

Thank you for your purchase.

Bill & Linda Rinella, owners

Exterior Siding

The siding is made in 4x8 sheets with grooves cut into the face, the long edge is beveled so that the siding overlays where they butt.

To identify which edge we want you to use, we will refer to the edge as either the 'LAP' Edge or the Tongue Edge. Nail siding with 8d galv. nails, spaced 12" apart.

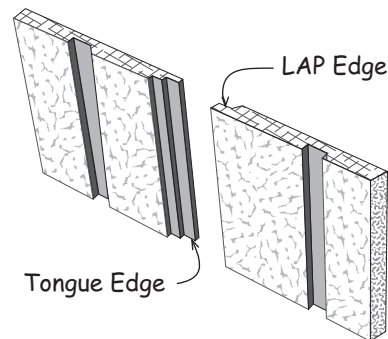

Tool List

- | | |
|--|---|
| <input type="checkbox"/> Hammer & Phillips Screwdriver | <input type="checkbox"/> Power Drill/Screwdriver |
| <input type="checkbox"/> Framing Square & Level | <input type="checkbox"/> Measuring Tape |
| <input type="checkbox"/> Hand or Circular Saw | <input type="checkbox"/> 2-8' Step Ladders & Ladder Jacks |

Always wear safety glasses when cutting or nailing!

Details for Optional Sturdy-Built Floor System

Foundation size is 12'-0" x 19'-9". Check local building codes in your area, the construction may have to change. For a concrete slab, install sill sealer as a moisture barrier between the concrete and the wall plates. Foam sill sealer can be purchased at home centers in rolls 3-1/2" or wider.

1. Cut (2) two 2x4-12' to a length of 12' -0". They will be used for the joist headers. Layout, from the left, for 12" on center joist spacing. The 'X' marks where floor joist will be placed.

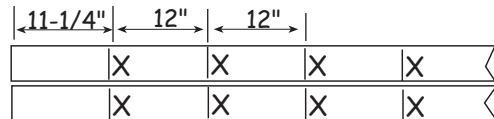

2. Cut (13) thirteen 2x4-12' floor joist to 11'-9". *Treated lumber may be thicker than 1-1/2"*. Take this into account when cutting the length of floor joists. Shorten the joist measurements if necessary to obtain 12'-0" building width.
3. Place 4x4-10' treated timbers on the ground. Cut (2) two 2x4-8' boards into 2' long blocks to secure the 4x4s where they butt together.
4. Install the floor joists cut above between the 12' joist headers. Secure with 16d galv. deck nails.
5. Place floor sections over the 4x4s. Square floor assembly. Measure the floor diagonally (corner to corner). Then measure the opposite corners. These measurements will be the same if the floor is square. To keep the 2x4 frame from moving, toenail frame to the 4x4 runners.

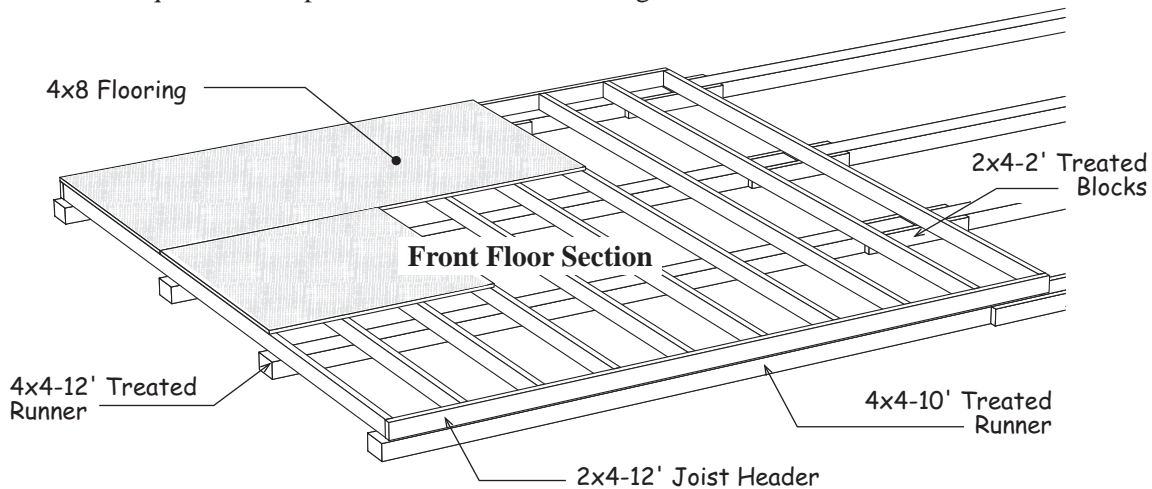

Assembly Instructions for Rear Floor Section

6. Cut (2) two 2x4-8' to a length of 7' -9". Layout for 12" joist spacing, *see above*.
7. Cut (9) nine 2x4-12' floor joist to 11'-9". Install floor joists between the joist headers. Install this section, **with the 12" spacing**, against the section assembled above.
8. Install 4x8 flooring over the 2x4s. Use 8d galv. spiral nails.

Material Description	12' x 20'
2x4 Headers_Blocks	4 pcs. 8'
2x4 Headers	2 pcs. 12'
2x4 Floor Joist	22 pcs. 12'
4x4 Treated Runners	8 pcs. 10'
Flooring 3/4"	8 pcs. 4x8
Screw Floor Nails	5 lb. 8d
Galv. Box Nails	5 lb. 16d

Step 1 Assemble Roof Trusses

1. Locate a 2x4 -12' board, *with angle cuts on both ends*, to be used for the truss bottom.
2. Position 105-3/4" long pre-cut 2x4 rafters on the 12' board.

3. Temporarily tack 2x4 blocks, *packed in kit*, around the truss members. This will insure that the trusses are built exactly the same.

4. Position a 2x4-17-1/2" block at the ridge.

5. Position a 16-3/4" long 2x4 gable stud at each end of the truss.

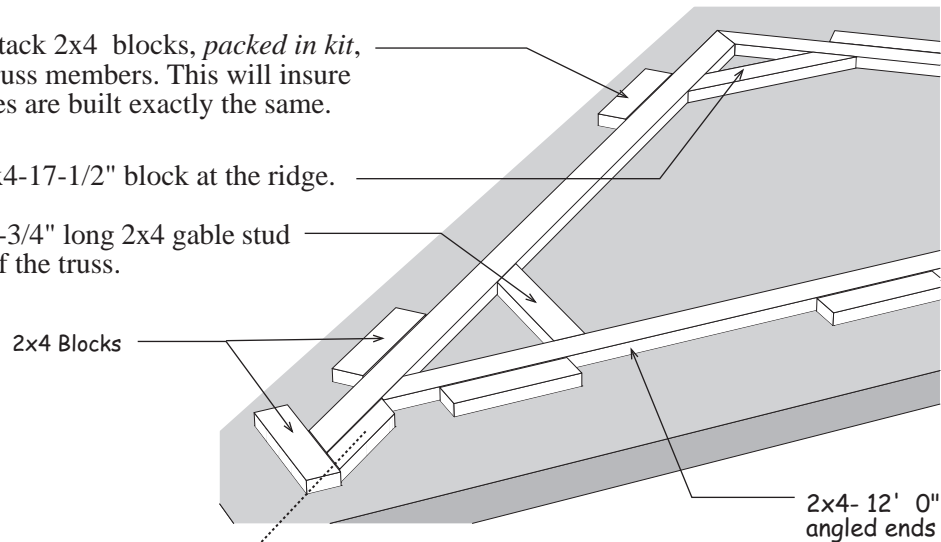

Important: To insure the proper overhang, insert a 11-1/4" long 2x3 gauge block (GB) on each end. Butt the 2x4 truss bottom against the block. Mark this end of the trusses with an 'X' mark. When you install the trusses later, install all the trusses with this end on the same side of the building.

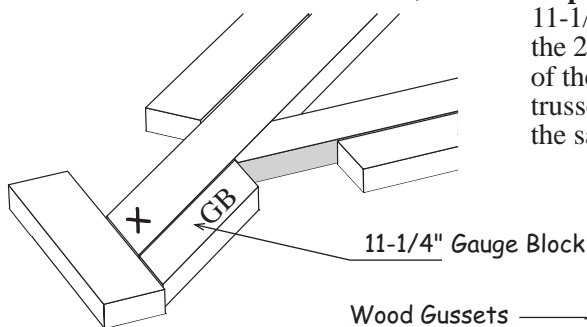

6. Install wood gussets to secure truss parts in place. Apply wood glue between gussets and 2x4s. Secure top gussets with (12) twelve 6d common nails. Secure the lower gussets with (16) sixteen 6d common nails.

7. Turn truss over and apply wood gussets to the opposite side of the trusses.

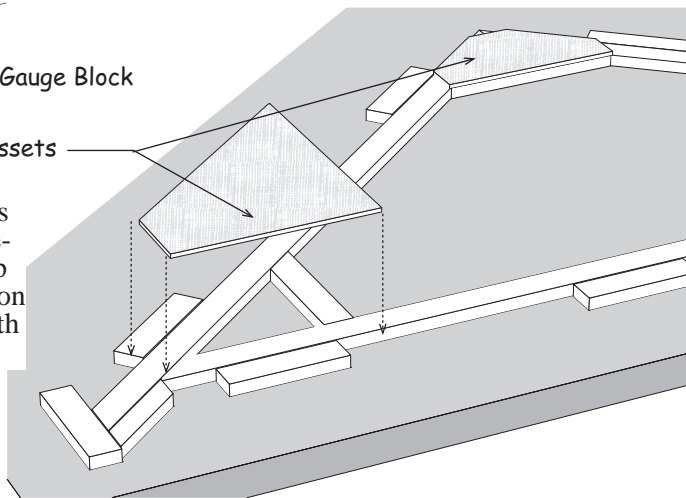

8. Repeat process to assemble (8) eight more trusses. Do Not remove the 2x4 blocks around the perimeter of the truss until the gables are assembled in the next step.

Step 2 Assemble Roof Gables

1. Select another 12' long 2x4, *with angle cuts on both ends*. Install pre-cut rafters and bottom gussets as in previous step. Install the bottom gussets on one side only.
2. Install 38-3/4" and 50" long 2x4 gable studs. Secure gable studs with 1" x 4" metal drive-on plates.
3. Install the upper wood gusset.

If installing the optional gable window, install a 2x2 board (packed with window) between the 53" long gable studs. Cut to fit.

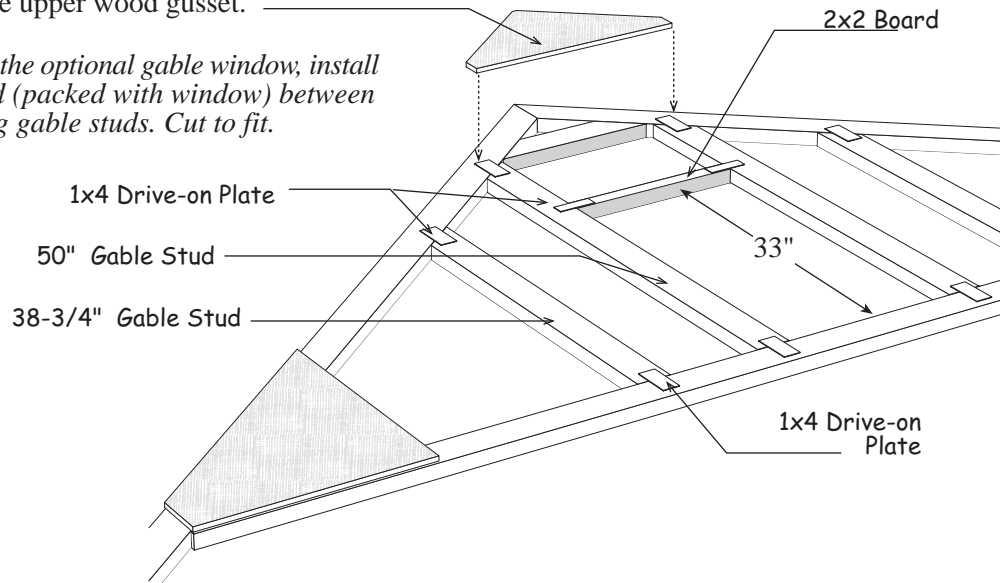

4. Repeat steps to assemble another roof gable.
5. Lay gable on flat surface with gussets facing down.
6. Remove 2x4 blocks used to hold truss parts in place. Secure (3) three blocks, *evenly spaced*, to the bottom 2x4 using 2-1/2" long wood screws.

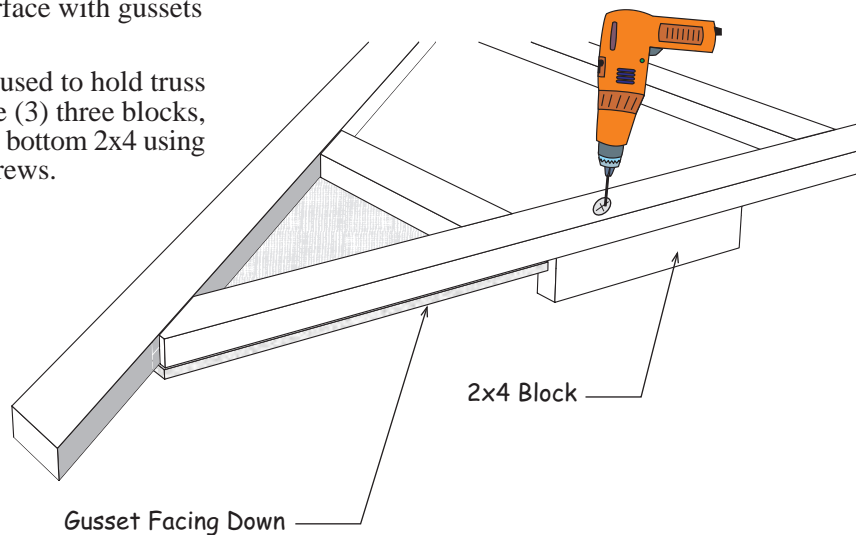

Step 3 Install Siding on Gables

1. Cut a 4x8 siding panel in half creating (2) two 48" siding panels. Install one of the pieces with the 'LAP' edge flush with the end of the bottom 2x4 board and extending 3/4" below the bottom 2x4. Cut siding flush with the top of the gable frame. Secure with 6d galv. nails.
2. Cut a 4x8 siding panel to a length of 66-1/2". Save the cutoff. Install the siding in the center. Cut siding flush with the top of the gable frame.
3. Install the remaining 48" siding panel on the end of the gable.

 Cut the window opening if you are installing the optional gable window. Instructions packed with windows.

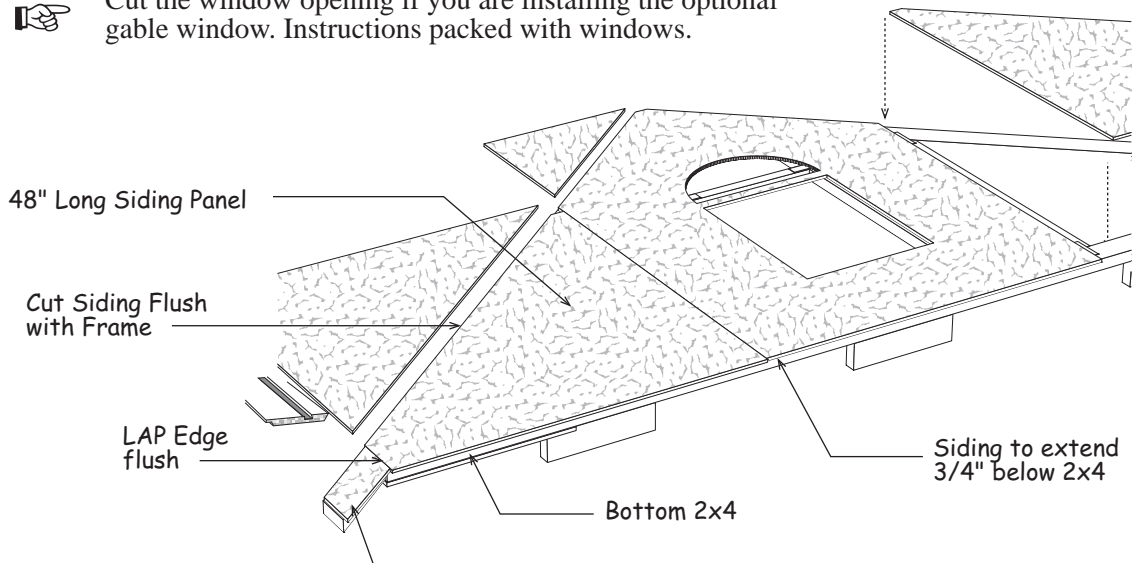

4. Cut siding and install on the ends of the gable. The siding should extend 1/2" below the 2x4 to receive the soffit when installed later.
5. Repeat to install siding on the rear gable.

Step 4 Install Gable Overhang

1. Install (2) two 105-3/4" long 2x4 rafters on the front gable. Install 2x4s extending 1/2" above the top of the gable frame to receive the roof sheathing when applied in a later step.
2. Repeat to install 2x4s on the rear gable.

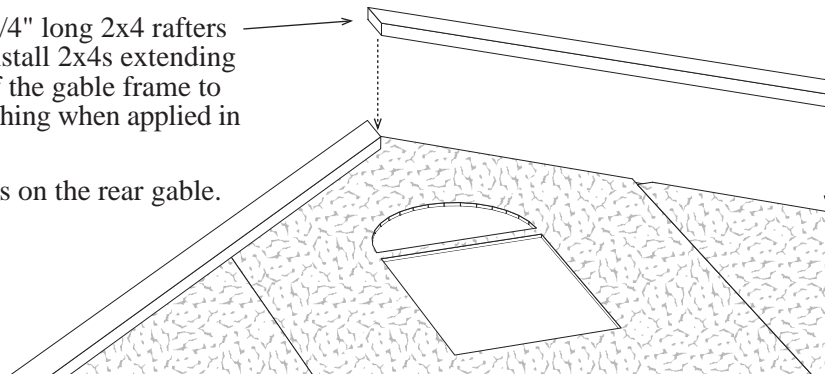

Step 5 Assemble 12' Back Wall

1. Position (4) four 2x4-72" boards together and indicate with 'X' marks, where the wall studs will be located.

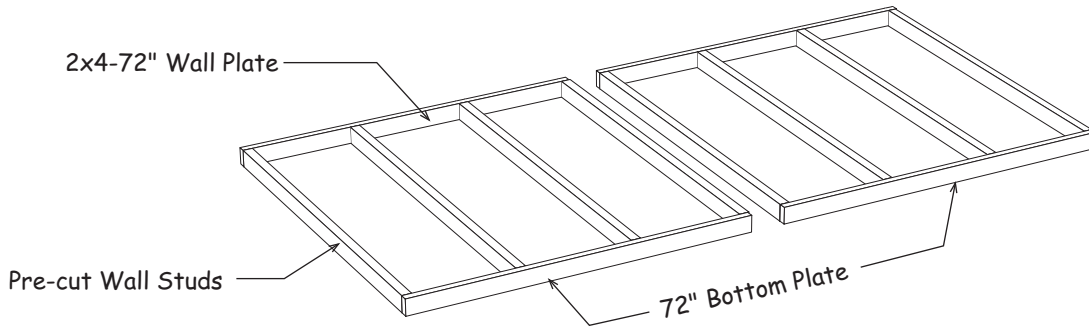
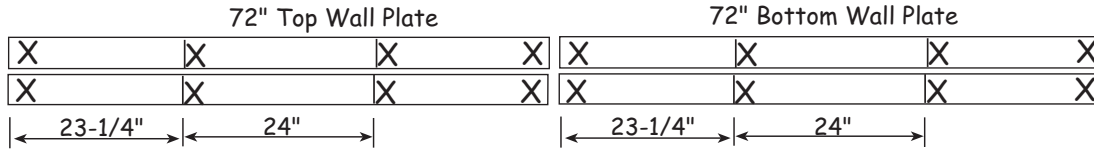

2. Install pre-cut wall studs between the top & bottom plates. Pre-cut wall studs will be 92-5/8" or 92-1/4" in length. Nail studs to wall plates with 10d sinkers, (2) two nails on each end.
3. Nail both wall frames together. Use 10d sinkers.
4. Square wall frame. Measure the wall diagonally (corner to corner). Then measure the opposite corners. These measurements will be the same if the wall is square.
5. Install the first siding panel with the 'LAP edge' flush with the end of the wall and extending 3/4" below the bottom plate. Tip: use a 1x4 trim board as a gauge. Nail siding with 8d galv. nails, spaced 12" apart.
6. Install (2) two more siding panels. Cut the last panel flush with the end of the frame.

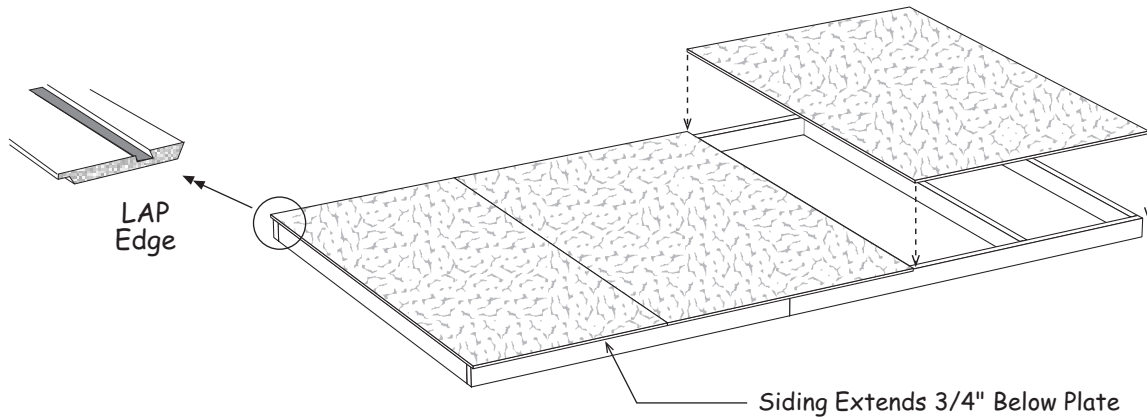

Step 6 Assemble 140-1/2" Long Sidewalls

1. Cut (2) two 2x4-12' to a length of 140-1/2". Position the boards together and indicate with 'X' marks, where the wall studs will be located.

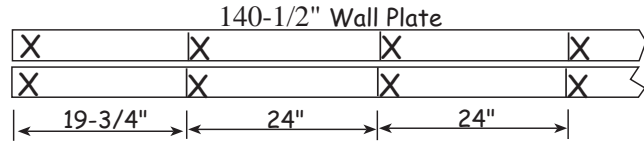

140-1/2" Wall Plate

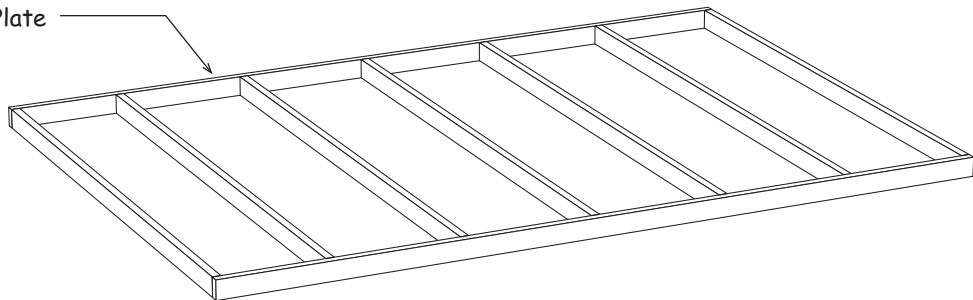

2. Install pre-cut wall studs between the top and bottom plates.
3. Assemble (1) one more 140-1/2" long sidewall frame.



If you are installing the optional walk-in door see the instructions at the back of the book.

4. Square wall frame. Install the first siding panel with the 'LAP edge' extending 3-1/2" beyond the end of the wall and extending 3/4" below the bottom plate.
5. Install (2) two more siding panels.

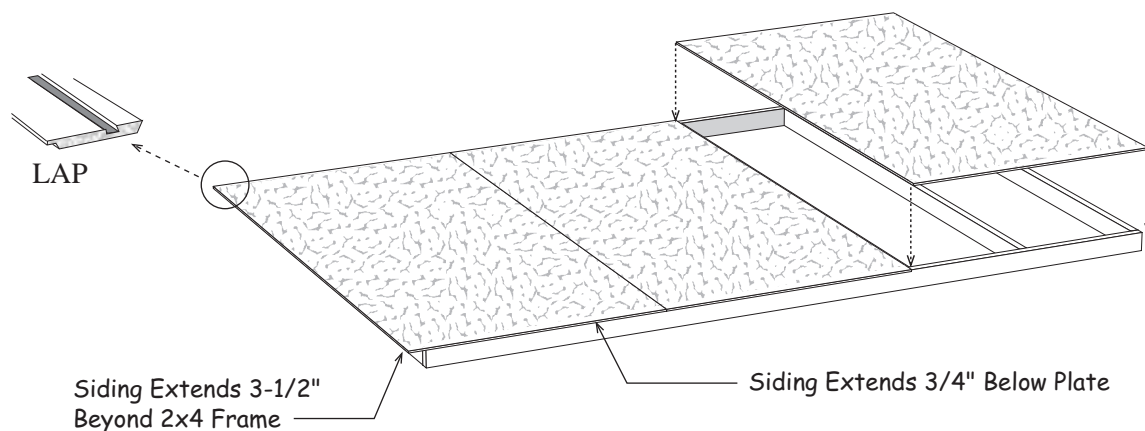

6. Repeat to apply siding to the other sidewall frame.

Step 7 Assemble 89-1/2" Long Sidewalls

1. Cut (2) two 2x4-8' to a length of 89-1/2". Position the boards together and indicate with 'X' marks, where the wall studs will be located.

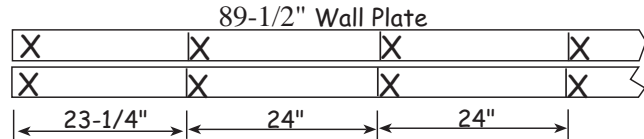

2. Install pre-cut wall studs between the top & bottom plates.
3. Butt wall frame to wall panel from previous step. **Do Not** nail these frames together so they can be separated later.
4. Install a siding panel but do not nail along the long edge that overlaps the other wall frame. You can nail this edge after the wall panels are installed. This will enable you to separate the wall panels making them easier to handle.
5. Cut the last siding panel to a width of 45". The last panel will extend 3-1/2" past the frame.
6. Repeat to assemble another sidewall frame. Separate walls and set aside.

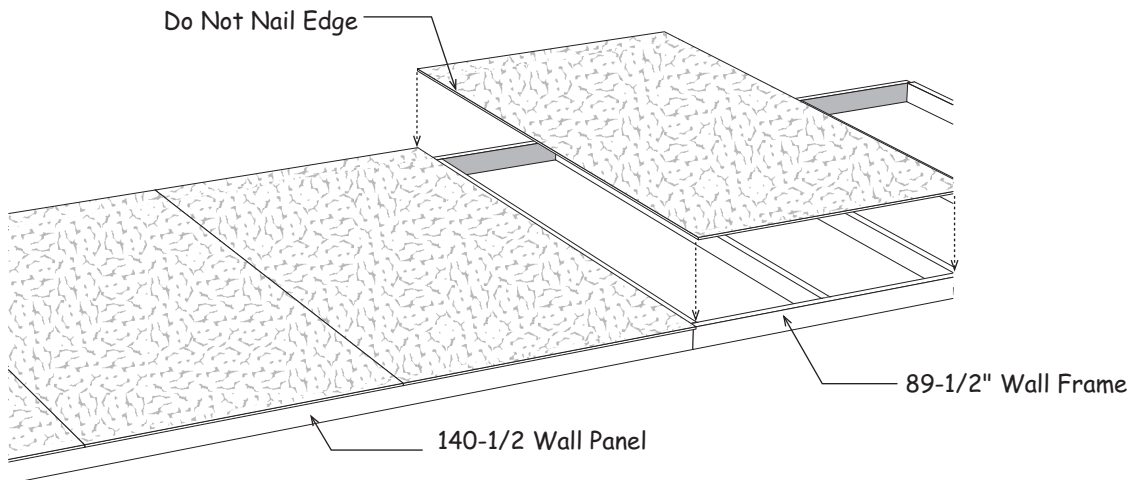

Step 8 Assemble Door Header

1. Locate (2) two 2x10-10' boards.
2. Cut these boards to a length of 99".
3. Cut filler boards from leftover gable siding.
4. Assemble the door header using 10d sinkers.

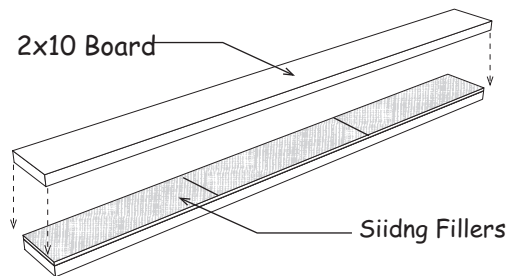

Step 9 Assemble 12' Door Wall

1. Gather the material listed below to assemble the door wall.

6	Pre-cut Wall Studs
4	2x4-6' Boards
1	Door Header from Step 8
1	2x4 Block

2. Install (4) four pre-cut wall studs between the 2x4-6' boards where shown. Temporarily secure the bottom 2x4-6' boards together with a 2x4 block.
3. Install the door header at the top of the door opening.
4. Cut and install (2) two pre-cut wall studs under door header.

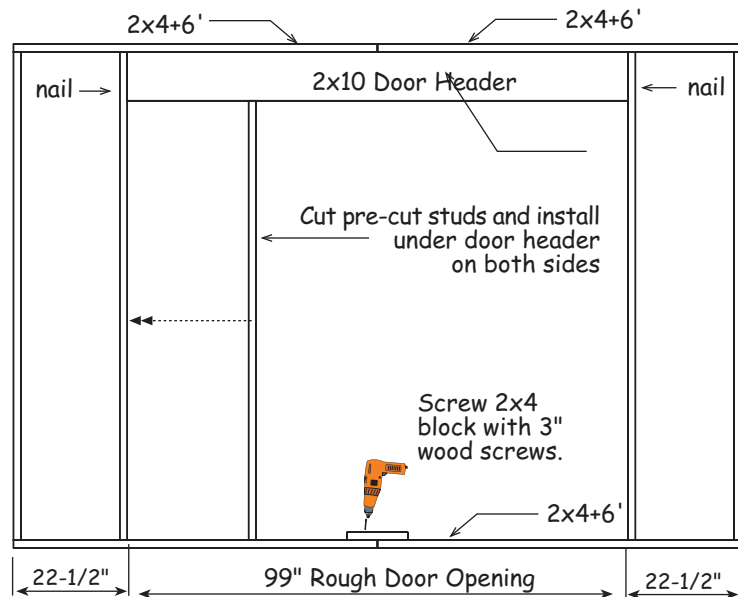

5. If the pre-cut wall studs supplied with our kit measure 92-5/8", install a 1x4-8' board under the door header to shorten the door opening.
6. Install a 4x8 siding panel on the left side of the wall panel. Before you install the siding, cut and remove the siding that extends into the door opening.
7. Install a siding panel, leftover from **Step 3**, above the door opening.
8. Install another 4x8 siding panel on the right side of the wall panel. Cut and remove the siding that extends into the door opening.

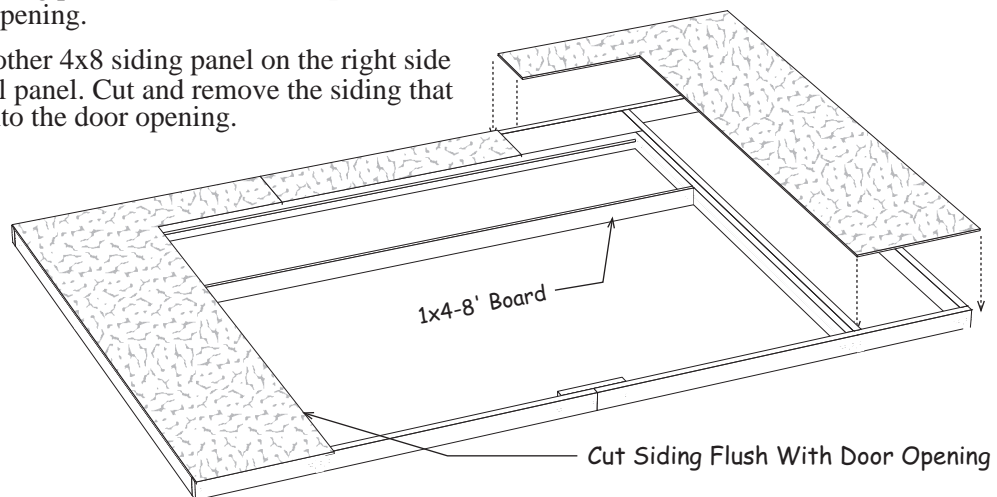

Step 10 Set Wall Panels

1. Set the back wall panel between the sidewalls. Secure wall panels together at the corners. Use (4) four 10d coated nails per corner. Nail wall panels to the floor. Nail through the bottom plate. Space 10d sinkers 24" apart.
2. Nail along the siding edge where the sidewall panels overlap.
3. Install the front wall frame between the sidewalls. Do not nail to floor in door opening.
4. Use pre-cut wall studs at each side of the door opening to hold the front wall straight.
5. Install a pre-cut wall stud to brace the right side wall where the wall panels meet.

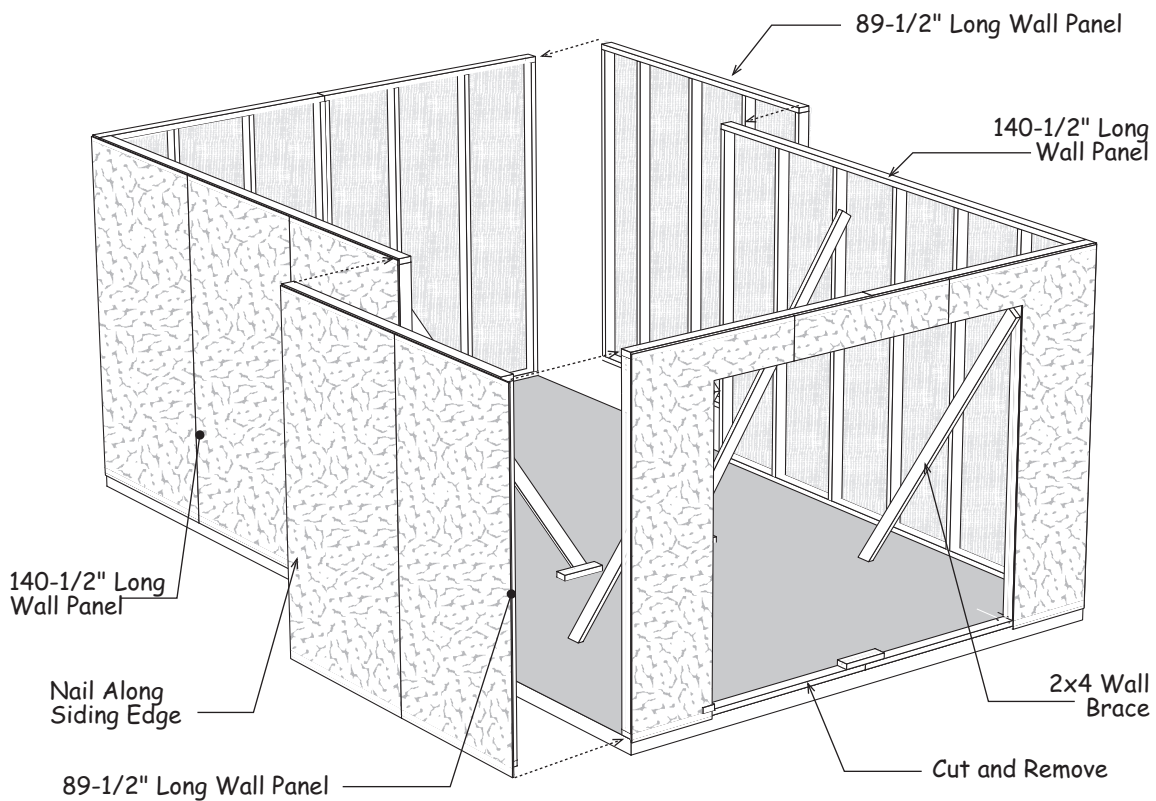

6. Cut and remove the bottom 2x4 in the door opening.

Step 11 Install 2x4 Tie Plates

1. Add (2) two more pre-cut 2x4s for wall bracing, on (1) one sidewall, where shown below. Make sure this wall is straight before installing wall braces.
2. Install a 2x4-8' board on the side wall, at the back corner of the building as shown below. Use 10d sinkers. Cut and install a 2x4-12' to finish. Repeat to install 2x4s on the opposite side walls.
3. Cut a 6' long 2x4 in half and install 3' long 2x4s at the rear corners. Cut and install a 6' long 2x4 between the 3' long 2x4s.

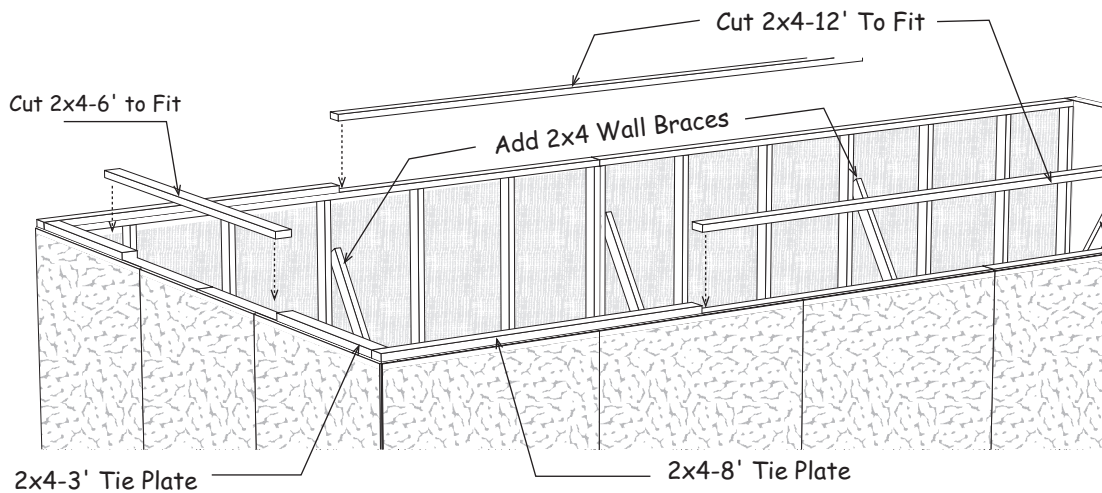

Step 12 Install Corner Trim

IMPORTANT: Lower Trim Must Be Installed Before Installing Roof Gables!

1. Tack 1-1/2" x 48" filler strips on top of the siding on the back wall.
2. Install (2) two 72-3/8" long 1x4 white pine trim boards flush with the siding on the sidewalls and flush with the top of the 2x4 tie plate. Use 8d galv. nails to install all trim.

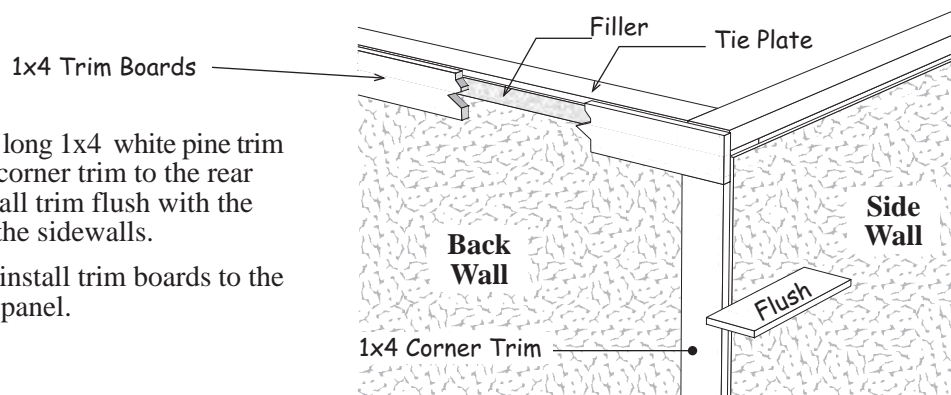

3. Install 95" long 1x4 white pine trim boards as corner trim to the rear walls. Install trim flush with the siding on the sidewalls.
4. Repeat to install trim boards to the front wall panel.

Step 13 Layout Roof Trusses

1. Measuring from back wall. Draw a line where the trusses will be positioned. Mark an 'X' to the side of this line.
2. From the first line, draw more lines 24" apart and put an 'X' to the side of these lines. This will place the trusses 24" on center.
3. When installing trusses, position the wood gusset on the line.

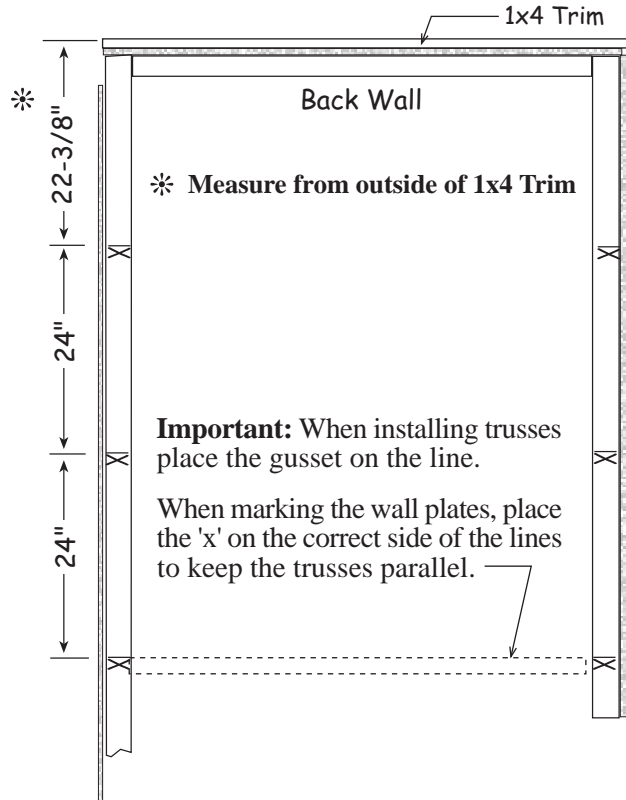

Step 14 Set Rear Gable

1. Install gable on the back wall. Secure bottom of gable by nailing gable blocks to wall plate.
2. Nail the bottom edge of the siding into the 1x4 trim. Use 8d galv. nails.

Important: Bottom edge of gable siding extends over 1x4 trim

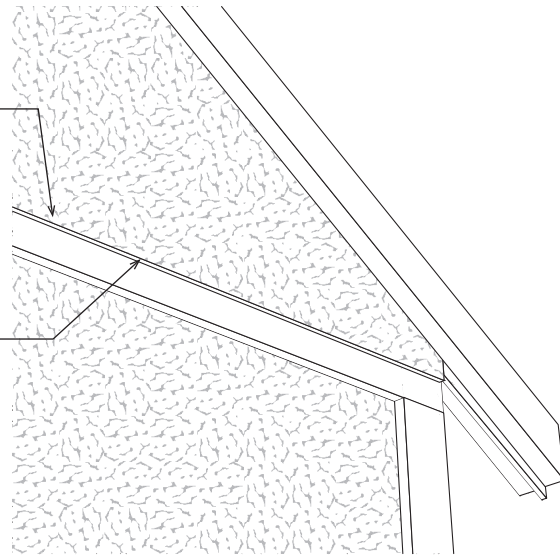

Step 15 Set Trusses

1. Starting from back gable install (4) four trusses with the wood gusset on the line and the truss bottom over the 'X' marks.
2. Secure trusses with the metal hangers and 1-1/2" long hanger nails.

IMPORTANT

Secure the trusses to the sidewall that has the wall bracing first. Make sure the opposite sidewall is plumb before securing trusses. The building width should be 12'-0" measuring outside of 2x4 tie plate to outside of 2x4 tie plate.

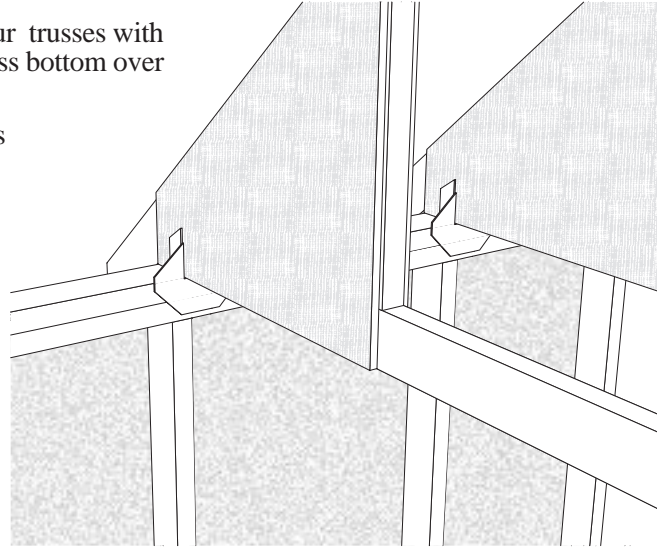

Step 16 Install Loft Flooring

 Before installing floor sheathing consider the location and size of access opening. Cut sheathing as appropriate.

1. Install (2) two 4x8 sheets of loft flooring on trusses. Notch floor around studs in the rear gable.

Make sure the trusses and walls remain plumb before nailing flooring. Nail floor to bottom 2x4 of gable and trusses with 7d coated nails. Space 12" apart.

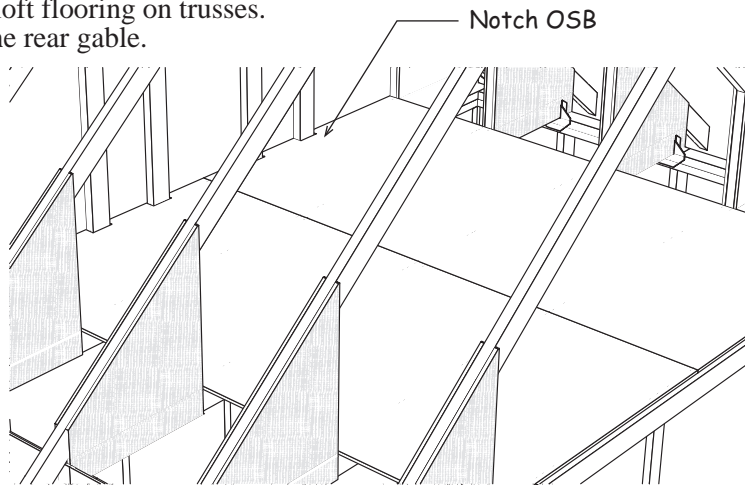

2. If necessary, cut flooring to the center of the 2x4.
3. Install the remaining trusses and the front gable panel
4. Install 4x8 sheets of loft flooring on trusses at the front and center of the building.

Step 17 Install Sidewall Trim & Soffit

 *It is easier to install the soffit if the corner and sidewall trim are installed first. This enables the soffit to rest on the trim where it meets the building. See lower detail.*

1. Install a 96-3/4" long 1x4 trim board flush with the corner trim on the back of the building. *This trim board has blue paint on one end.* Locate a 7/16" x 3" x 8" gauge block packed in the hardware bag. Place this gauge block under the truss overhang and butt the corner trim against it. Use 8d galv. nails.
2. Install another 96-3/4" long 1x4 flush with front wall trim.
3. Install 4' long 1x4 trim along the top of the sidewall. Use the gauge block to set where the trim will be installed.
4. Install a 1x4-12' trim board along the top of the sidewall. Cut to fit a 1x4-4' trim board to finish.
5. Repeat on opposite sidewall.

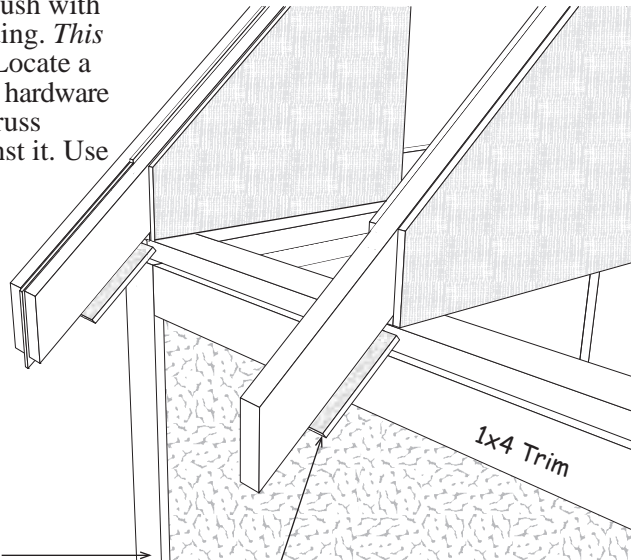

96-3/4' Long Corner Trim

7/16" Gauge Block

6. Starting from back gable install a 4'x10-5/8" soffit panel with bevelled edge. Cut the length so the panel ends at center of 2nd truss. Insure bevelled edge is facing truss ends. Use 6d galv. nails.
7. Install (2) two 6' long soffit panels.
8. Install a 4' long soffit panel to finish.
9. Repeat on opposite sidewall.

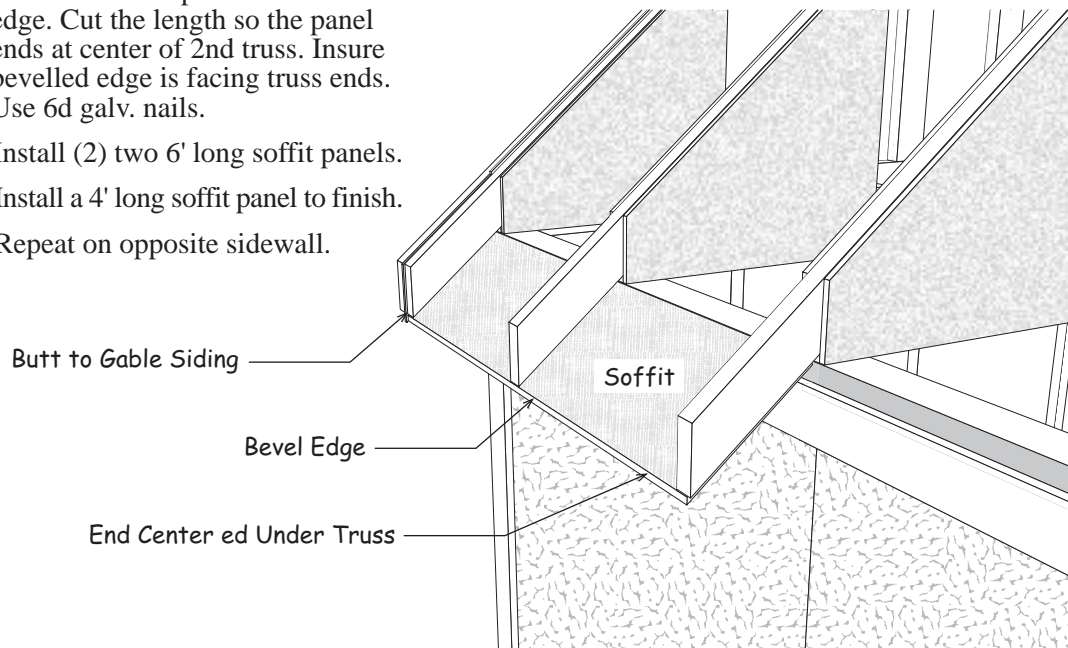

Butt to Gable Siding

Bevel Edge

End Center ed Under Truss

Step 18 Install 1x6 Fascia on Sidewalls

1. Install a 121-1/2" long 1x6 trim board at the rear of the building, flush with the face of the 2x4. Install the 1x6 board so the face of the board is aligned with the top of the trusses. Use a straight edge as shown below. Use 8d galv. nails.
2. Install a 1x6-8' board.
3. Cut 1x6-8' board flush with the 2x4 on the front gable. Save the cutoff for to finish opposite side.
4. Repeat on opposite sidewall.

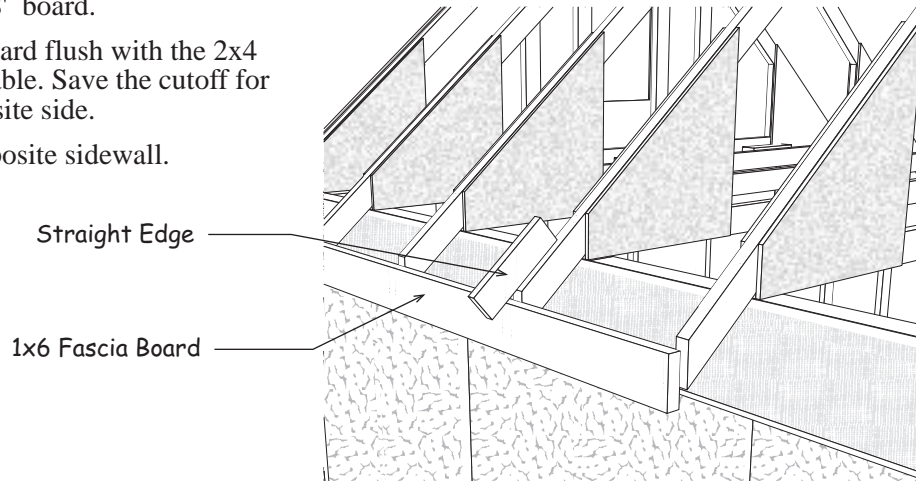

Step 19 Install Roof Sheathing

1. Install 4x8 roof sheathing starting at the lower back corners. The bottom edge of the sheathing should extend past the end of the trusses and rest on the 1x6 fascia. Make sure the trusses and gables are plumb and the roof sheathing meets the center of the trusses.
2. Install roof sheathing per layout below. The top row of sheathing is supplied in our component kit. There will be a gap at the top to allow ventilation if ridge vent is applied. Insert (2) two ply-clips into the roof sheathing between each truss at the top row, see drawing on next page. Secure sheathing with 7d sinkers nails. Space nails 12" apart.

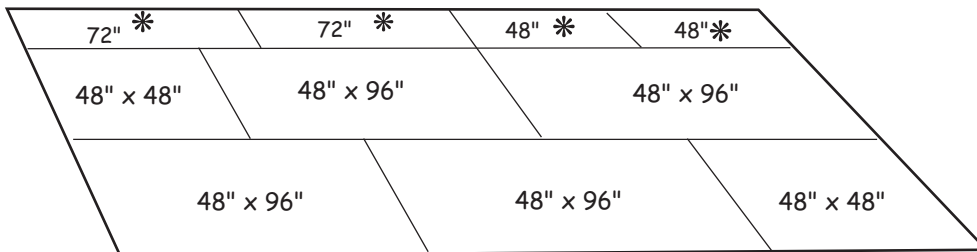

* Supplied in our component kit.

Optional ridge vent provides ideal ventilation.

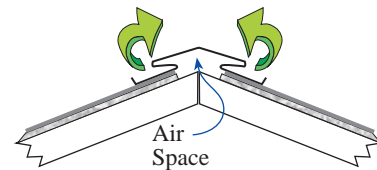

Step 19 Install Roof Sheathing Continued

3. Install 1x6 trim on the rear gable, flush with the top of the 2x4s. Use 8d galv. nails, spaced 12".

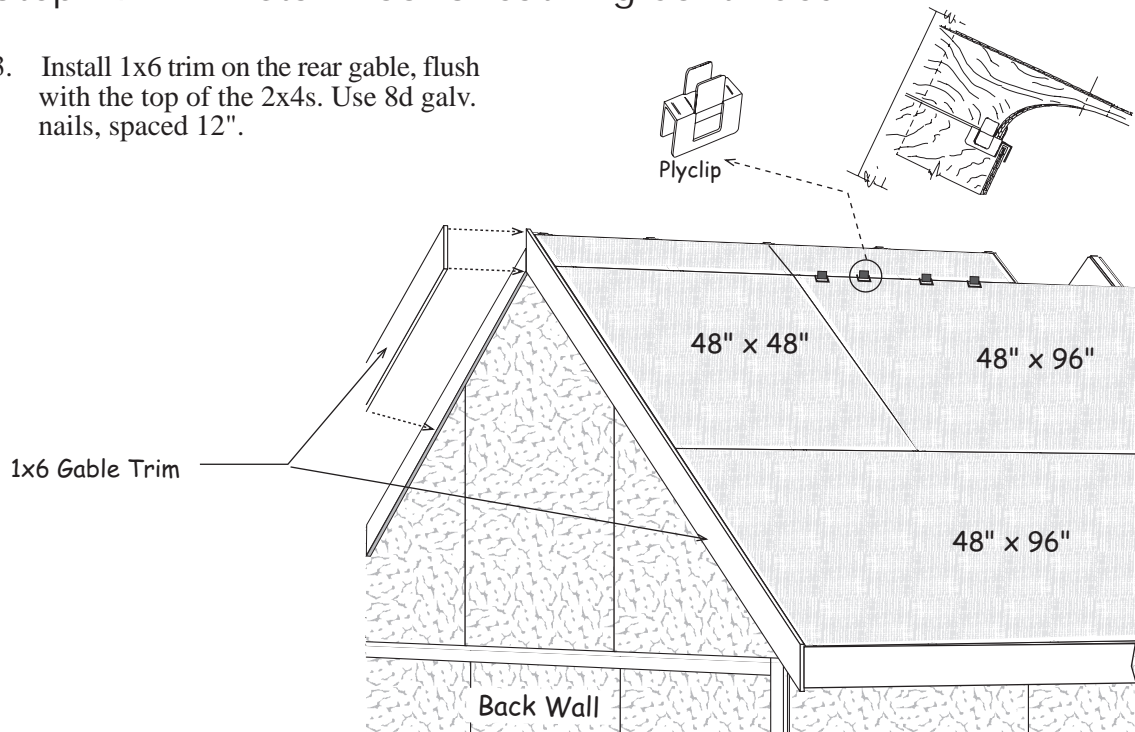

Step 20 Install Front Gable Trim and Door Trim

1. Install 1x6 trim boards over the 2x4 boards, flush with the top of the 2x4s.

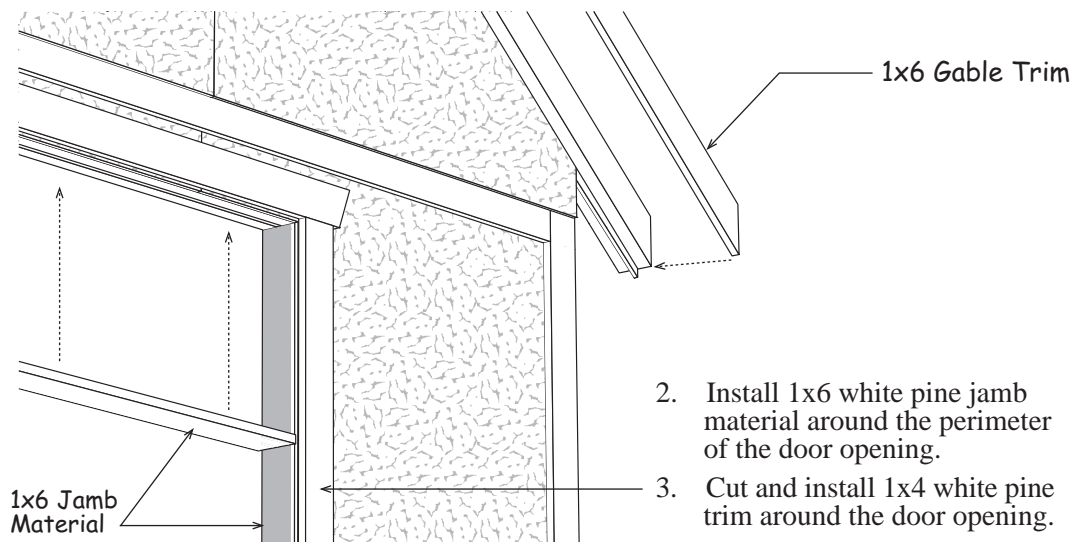

Step 21 Install 2x4 Jamb Support

Cut leftover wall bracing and install 2x4s around the door opening against the 1x6 door jamb.

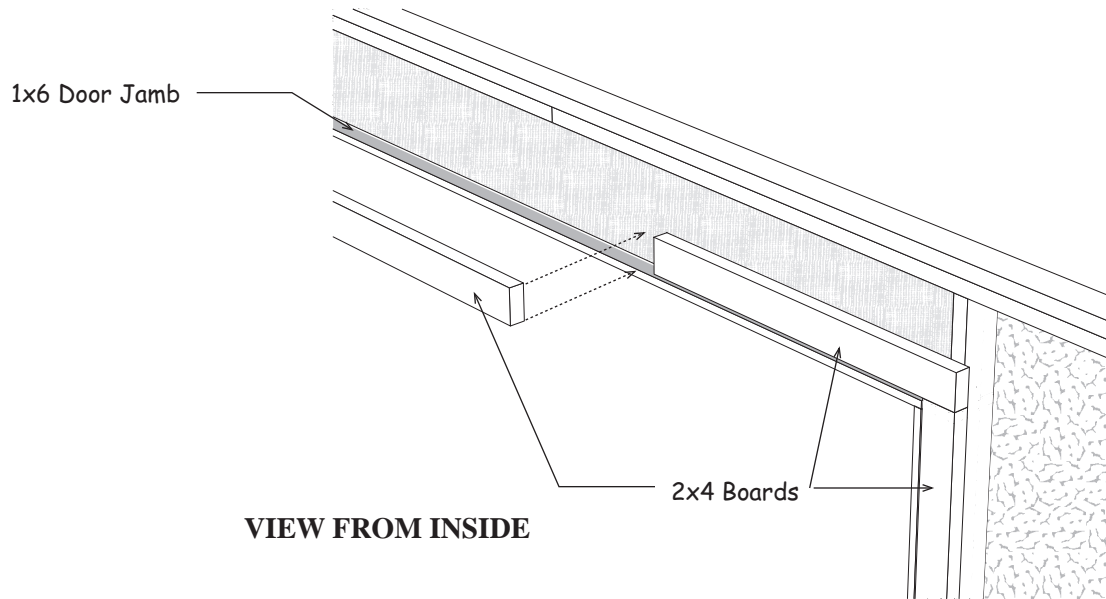

Install Optional Door Sill

If you ordered the optional floor, install the galvanized door sill. Secure sill with pan head screws.

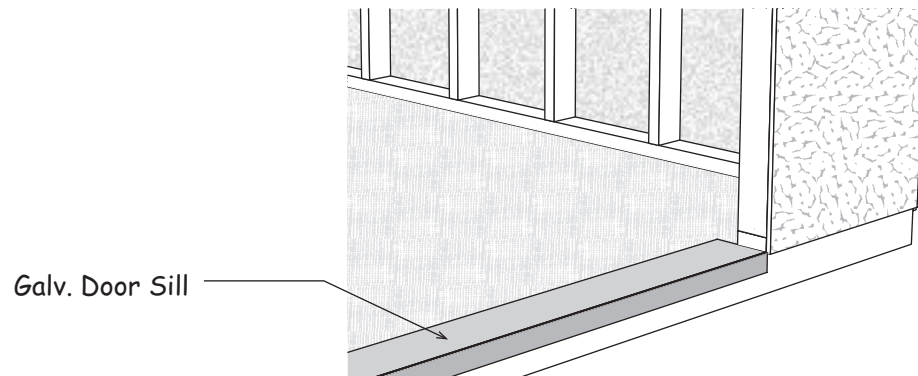

Supplement Details

 This assumes a 92-5/8" long stud length. Adjust accordingly if stud length differs

1. If you purchased a 32"x80" entry door, locate where you want the opening to be and build a 37-1/2" door header. You'll need to cut (4) four 37-1/2" long 2x4s, (3) three 5-5/8" long 2x4s and a 3-1/2"x37-1/2" piece of OSB. If you have a different size door adjust accordingly.
2. Assemble header as shown in Detail 'A'. First assemble (2) two 37-1/2" 2x4s and OSB. Next assemble (1) one 37-1/2" 2x4 and (3) three 5-5/8" 2x4s. Nail this assembly to bottom of previous assembled pieces. Last nail the remaining 2x4 to the 5-5/8" boards. Use 10d sinkers for all.

Detail 'A'

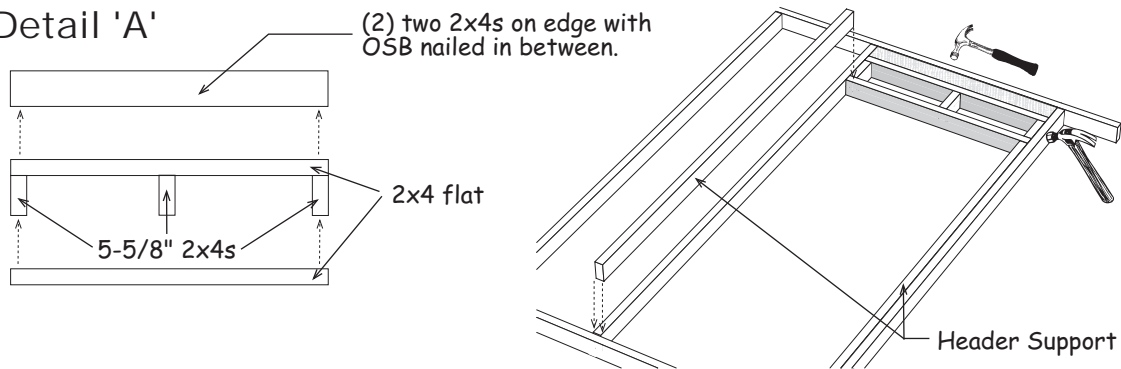

3. Secure the header by nailing through the top plate and wall studs with 10d sinkers.
4. Cut (2) two header supports from pre-cut wall studs and install under the door header.

Install Roofing — Not Supplied in Kit

1. Install metal roof edging along the end walls and the front edge of the roof sheathing.

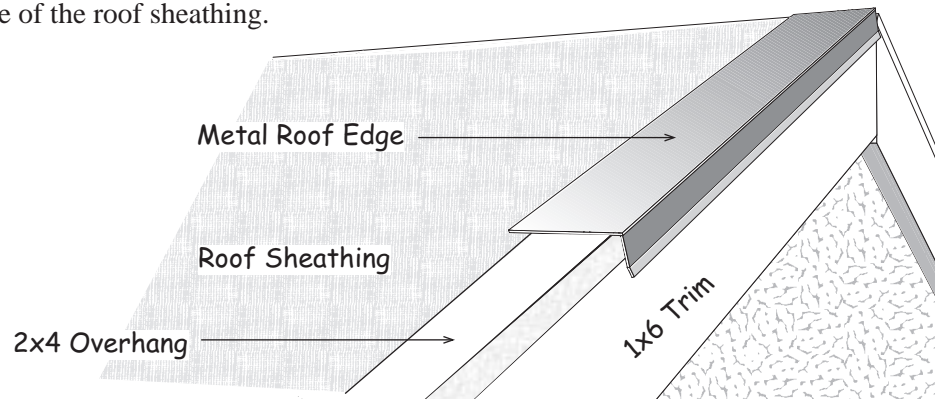

2. Install shingles according to the instructions on the wrapper. If you need more detailed instructions on installing shingles, there are good publications at book stores or newsstands.

Qty.	<i>Material Packaged In Component Kit</i>		Qty.	<i>Material Packaged In Component Kit</i>	
11	Truss Bottom	2x4 144"	20	7/16"	24" x 11" Truss Gussets
26	Truss Rafters	2x4 105-3/4"	40	7/16"	24" x 24" Truss Gussets
12	Wall Plates	2x4 72"	4	7/16"	9-3/4" x 72" Sheathing
4	Gable Studs	2x4 50"	4	7/16"	9-3/4" x 48" Sheathing
4	Gable Studs	2x4 38-3/4"	4	3/8"	Soffit Boards 4' x 10-5/8"
22	Gable & Truss Studs	2x4 16-3/4"	4	3/8"	Soffit Boards 6' x 10-5/8"
11	Truss Blocks	2x4 17-1/2"			
4	White Pine Trim	1x4 72-3/8"	6	3/8"	Filler Boards 4' x 1-1/4"
4	White Pine Wall Trim	1x4 48"	6	lbs.	10d Sinkers
2	White Pine Wall Trim	1x4 144"	6	lbs.	8d Galv. Nails
4	White Pine Corner Trim	1x4 95"	4	lbs.	7d Sinkers
4	White Pine Corner Trim	1x4 96-3/4"	2	lbs.	6d Galv. Nails
4	White Pine Gable Trim	1x6 107"	6	lbs.	6d Common
2	White Pine Fascia	1x6 121-1/2"	1-1/4	lbs.	1-1/2" Hanger Nails
5	White Pine Fascia	1x6 96"	24	2-1/2"	Wood Screws
2	Truss Gauge Blocks	2x3 10-5/8"	18	H11z	Truss Hangers
10	Truss Jig Blocks	2x4 10"	42		Plyclips for Roof Sheathing
2	Soffit Gauge Blocks	7/16" 3" x 8"	22	1x4	Drive-on Metal Plates
			4	16 oz.	Bottles Wood Glue

Qty.	<i>Material Supplied by Local Supplier</i>	
45 pcs.	2x4-Pre-cut Wall Studs	
6 pcs.	2x4-8' Wall & Tie Plates	
6 pcs.	2x4-12' Wall & Tie Plates	
2 pcs.	2x10-10' Door Header	
3 pcs.	1x4-8' Door Trim	
1 pc.	1x4-10' Door Trim	
3 pcs.	1x6-8' Door Jamb	
19 pcs.	Exterior Siding	4x8
10 pcs.	OSB Sheathing	4x8
5 pcs.	OSB Loft Floor	4x8

Optional Roof Covering

13 bdl. Roof Shingles
9 pcs. Roof 'drip' Edge-10'