



2 x 6" BELT AND DISC SANDER



Read carefully and follow all safety rules and operating instructions before first use of this product.

GETTING STARTED

STRUCTURAL REQUIREMENTS

Make sure all supporting structures and load attaching devices are strong enough to hold your intended loads. If in doubt, consult a qualified structural engineer.

ELECTRICAL REQUIREMENTS

The power supply to the Sander needs to be 120 volt/ 3.5 amp, single phase, 60 Hz. The standard allowable voltage variation is plus or minus 10%.

TOOLS NEEDED:

Standard mechanic's hand tool set.

UNPACKING

WARNING: Be careful not to touch overhead power lines, piping, lighting, etc. if lifting equipment is used. Sander weighs approximately 32 lbs, proper tools, equipment and qualified personnel should be employed in all phases of unpacking and installation. Carton should be handled with care to avoid damage from dropping, bumping, etc. Store and unpack carton with correct side up. After unpacking Sander, inspect carefully for any damage that may have occurred during transit. Check for loose, missing or damaged parts. If any damage or loss has occurred, claim must be filed with carrier immediately. Check for completeness. Immediately report missing parts to dealer.

Sander is shipped partially assembled. End user will need to assemble loose parts to machine.

IMPORTANT: The tool has been coated with a protective coating. In order to ensure proper fit and operation, the coating must be removed. Remove coating with mild solvents such as mineral spirits and a soft cloth. Nonflammable solvents are recommended. After cleaning, cover all exposed metal surfaces with a light coating of oil.

CAUTION: Never use highly volatile solvents. Avoid getting cleaning solution on paint as it may tend to deteriorate these finishes. Use soap and water on painted components.

CONTENTS:

- 2 x 6" Belt and Disc Sander (1)
- Disc table (1)
- Abrasive disc (1)
- Meter gauge assembly (1)
- Belt table (1)
- Parts bag (1) includes: work stop; two knobs; one 10-1.5 x 16mm socket head bolt; one 10mm flat washer; two 6mm washers; one each 5, 6 and 8mm hex wrenches and one 12mm open end wrench.
- Operating Instructions and Parts Manual (1)

UNPACK:

• Do not discard packing materials until after machine has been inspected for damage and completeness. Locate loose parts and set aside.

INSPECT:

• After unpacking the unit, carefully inspect for any damage that may have occurred during transit. Check for loose, missing or damaged parts. Shipping damage claims must be filed with the carrier.

- All tools should be visually inspected before use, in addition to regular periodic maintenance inspections.
- Be sure that the voltage labeled on the unit matches your power supply.



SEE GENERAL SAFETY INSTRUCTIONS, CAUTIONS AND WARNINGS AS SHOWN.

SAFETY RULES

WARNING: For your own safety, read all of the instructions and precautions before operating tool.



PROPOSITION 65 WARNING: Some dust created by using power tools contain chemicals known to the state of California to cause cancer, birth defects or other reproductive harm.

Some examples of these chemicals are:

- Lead from lead-based paints.
- Crystalline silica from bricks and cement and other masonry products.
- Arsenic and chromium from chemically-treated lumber.

Your risk from these exposures varies, depending on how often you do this type of work. To reduce your exposure to these chemicals: work in a well ventilated area and work with approved safety equipment. Always wear **OSHA/NIOSH** approved, properly fitting face mask or respirator when using such tools.

WARNING: Always follow proper operating procedures as defined in this manual even if you are familiar with the use of this or similar tools. Remember that being careless for even a fraction of a second can result in severe personal injury.

BE PREPARED FOR JOB

- Wear proper apparel. Do not wear loose clothing, gloves, neckties, rings, bracelets or other jewelry which may get caught in moving parts of machine.
- Wear protective hair covering to contain long hair.
- Wear safety shoes with non-slip soles.
- Wear safety glasses complying with United States ANSI Z87.1. Everyday glasses have only impact resistant lenses. They are **NOT** safety glasses.
- Wear face mask or dust mask if operation is dusty.
- Be alert and think clearly. Never operate power tools when tired, intoxicated or when taking medications that cause drowsiness.

PREPARE WORK AREA FOR JOB

- Keep work area clean. Cluttered work areas invite accidents.
- Do not use power tools in dangerous environments. Do not use power tools in damp or wet locations. Do not expose power tools to rain.
- Work area should be properly lighted.
- Proper electrical receptacle should be available for tool. Three-prong plug should be plugged directly into properly grounded, three-prong receptacle.
- Extension cords should have a grounding prong and the three wires of the extension cord should be of the correct gauge.
- Keep visitors at a safe distance from work area.
- Keep children out of workplace. Make workshop childproof. Use padlocks, master switches or remove switch keys to prevent any unintentional use of power tools.

SAFETY RULES (CONTINUED)

TOOL SHOULD BE MAINTAINED

- Always unplug tool prior to inspection.
- Consult manual for specific maintaining and adjusting procedures.
- Keep tool lubricated and clean for safest operation.
- Remove adjusting tools. Form habit of checking to see that adjusting tools are removed before switching machine on.
- Keep all parts in working order. Check to determine that the guard or other parts will operate properly and perform their intended function.
- Check for damaged parts. Check for alignment of moving parts, binding, breakage, mounting and any other condition that may affect a tool's operation.
- A guard or other part that is damaged should be properly repaired or replaced. Do not perform makeshift repairs. (Use parts list provided to order repair parts.)

KNOW HOW TO USE TOOL

- Use right tool for job. Do not force tool or attachment to do a job for which it was not designed.
- Disconnect tool when changing abrasive belt or disc.
- Avoid accidental start-up. Make sure that the tool is in the OFF position before plugging in.
- Do not force tool. It will work most efficiently at the rate for which it was designed.
- Use of improper accessories may cause risk of injury to persons.
- Handle workpiece correctly. Protect hands from possible injury.
- Turn machine off if it jams. Belt jams when it digs too deeply into workpiece. (Motor force keeps it stuck in the work.)
- Never leave tool running unattended. Turn power off and do not leave tool until it comes to a complete stop.
- Do not overreach. Keep proper footing and balance.
- Never stand on tool. Serious injury could occur if tool is tipped or if belt or disc is unintentionally contacted.
- Keep hands away from moving parts and sanding surfaces.
- Know your tool. Learn its operation, application and specific limitations.
- Support workpiece with miter gauge, work stop or work table.
- Maintain 1/16" maximum clearance between table and sanding belt or disc.

CAUTION: Think safety! Safety is a combination of operator common sense and alertness at all times when tool is being used.

WARNING: Do not attempt to operate tool until it is completely assembled according to instructions.

SPECIFICATIONS

Belt size	2 x 42", 80 grit
Belt platen area	7¼ x 2"
Belt table dimensions	6¾ x 9"
Belt table tilts	0 to 60°
Belt speed	4480 FPM
Disc diameter	6", 80 grit

Disc table dimensions	6½ x 8"
Disc table tilts	0 to 45°
Disc dust collection chute	1½" diameter
Disc speed	3590 RPM
Base dimensions	7⅝ x 9"
Switch	SP, locking rocker
Motor	120V, 3.5 AMPS
Weight	32 lbs
Shipping weight	35 lbs

ASSEMBLY

Refer to Figures 1 through 3.

CAUTION: Do not attempt assembly if parts are missing. Use this manual to order repair parts.

ATTACH ABRASIVE DISC TO ALUMINUM DISC

1. Remove dust chute by loosening screws and bolts.
2. Remove the adhesive cover from the back of the abrasive disc.
3. Center abrasive on aluminum disc and press to paste.
4. Make sure abrasive is pasted evenly on the aluminum disc.
5. Replace dust chute.

ASSEMBLE DISC TABLE

Refer to Figure 1.

1. Slide table onto disc guard as shown.
2. Set the disc table at right angle to the aluminum disc and secure the table position using two knobs and flat washers

ADJUST DISC TABLE ANGLE

Refer to Figure 1.

1. The disc table is adjustable from 0 to 45 degree for beveled work. To adjust disc table, loosen 2 knobs and flat washers and adjust to desired angle
2. Use scale on disc table trunnions to set disc table from 0 to 45 degree to abrasive disc
3. When disc table is at desired angle, lock into position by tightening the knobs

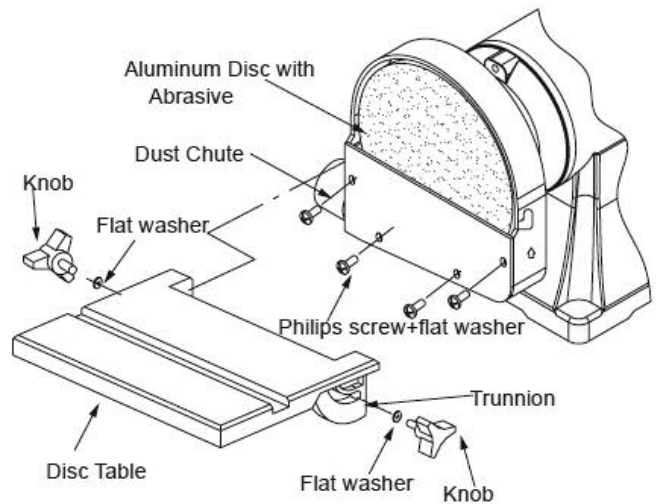

Figure 1 - Assemble and adjust disc table.

ASSEMBLY (CONTINUED)

ASSEMBLE BELT TABLE

Refer to Figure 2.

1. Mount belt table to left side of belt housing using hex socket head screw and flat washer.
2. Set the belt table at right angle to the belt
3. Be sure gap between table and belt is 1/16" or less. Tighten socket head screw to secure table position.

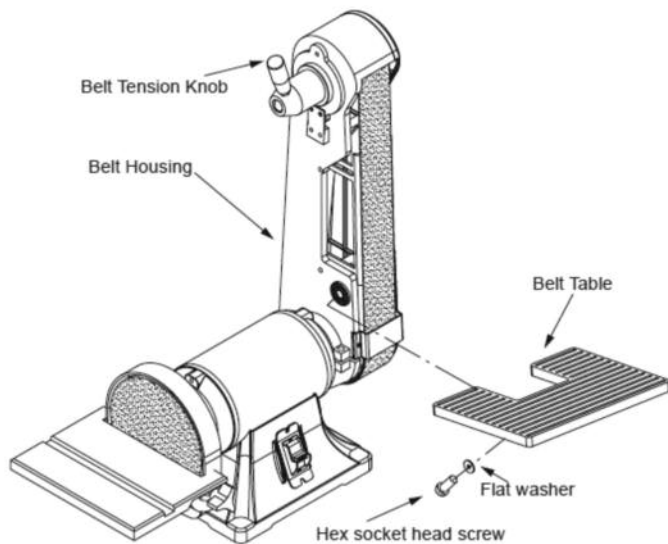

Figure 2 - Assemble belt table.

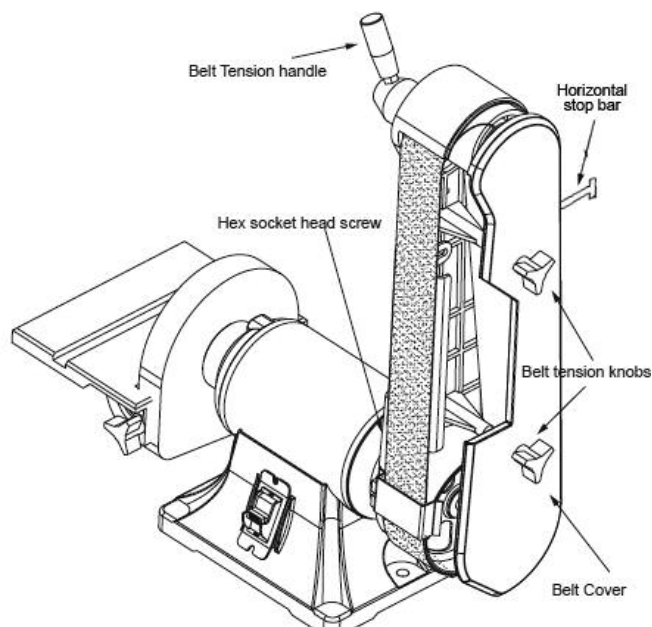

Figure 3 - Horizontal stop bar.

INSTALLATION

Refer to Figures 4 and 5.

WARNING: Operation of any power tool can result in foreign objects being thrown into eyes which can result in severe eye damage. Always wear safety goggles complying with United States ANSI Z87.1 before commencing power tool operation.

ELECTRICAL CONNECTIONS

WARNING: All electrical connections must be performed by a qualified electrician. Make sure tool is off and disconnected from power source while motor is mounted, connected, reconnected or anytime wiring is inspected.

WARNING: All electrical connections must be performed by a qualified electrician.

WARNING: Do not connect sander to the power source until all assembly steps have been completed.

POWER SOURCE

1. The motor is designed for operation on the voltages and frequency specified.
2. Normal loads will be handled safely on voltages not more than 10% above or below the specified voltage.
3. Running the unit on voltages which are not within the range may cause overheating and motor burnout.
4. Heavy loads require the voltage at motor terminals be not less than the voltage specified. Power supply to the motor is controlled by a single pole locking rocker switch. Remove the key to prevent unauthorized use.

GROUNDING INSTRUCTIONS

Refer to Figures 4 and 5.

WARNING: Improper connection of equipment grounding conductor can result in the risk of electrical shock. Equipment should be grounded while in use to protect operator from electrical shock. Check with a qualified electrician if grounding instructions are not understood or if in doubt as to whether the tool is properly grounded.

This equipment is for use on less than 150V, and is equipped with an approved 3-conductor cord and a 3-prong, grounding type plug (see Figure 4) for your protection against shock hazards.

Grounding plug should be plugged directly into a properly installed and grounded 3-prong grounding-type receptacle.

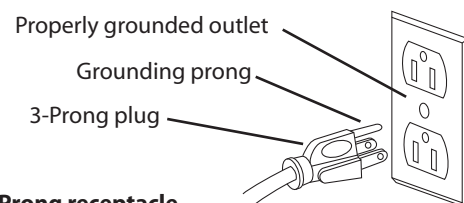

Figure 4 - 3-Prong receptacle

Do not remove or alter grounding prong in any manner. In the event of a malfunction or breakdown, grounding provides a path of least resistance for electrical shock.

WARNING: Do not permit fingers to touch the terminals or plug when installing or removing from outlet.

Plug must be plugged into matching outlet that is properly installed and grounded in accordance with all local codes and ordinances. Do not modify plug provided. If it will not fit in outlet, have proper outlet installed by a qualified electrician.

Inspect tool cords periodically, and if damaged, have repaired by an authorized service facility.

Green (or green and yellow) conductor in cord is the grounding wire. If repair or replacement of the electric cord or plug is necessary do not connect the green (or green and yellow) wire to a live terminal.

Where a 2-prong wall receptacle is encountered, it must be replaced with a properly grounded 3-prong receptacle installed in accordance with National Electric Code and local codes and ordinances.

INSTALLATION (CONTINUED)

WARNING: This work should be performed by a qualified electrician.

A temporary 3-prong to 2-prong grounding adapter (See Figure 5) is available for connecting plugs to a two pole outlet if it is properly grounded.

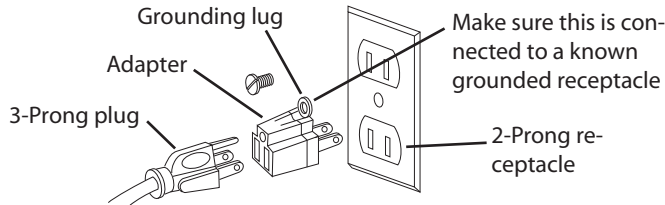

Figure 5 – 2-Prong receptacle with adapter

Do not use a 3-prong to 2-prong grounding adapter unless permitted by local and national codes and ordinances.

(A 3-prong to 2-prong grounding adapter is not permitted in Canada.) Where permitted, the rigid green tab or terminal on the side of the adapter must be securely connected to a permanent electrical ground such as a properly grounded water pipe, a properly grounded outlet box or a properly grounded wire system.

Many cover plate screws, water pipes and outlet boxes are not properly grounded. To ensure proper ground, grounding means must be tested by a qualified electrician.

EXTENSION CORDS

- The use of any extension cord will cause some drop in voltage and loss of power.
- Wires of extension cord must be sufficient in size to carry and maintain adequate voltage.
- Do not use extension cords over 25 ft. Cord must be at least 18 A.W.G.
- Use only 3-wire extension cords having 3-prong grounding type plugs and 3-pole receptacles which accept the tool plug.
- If the extension cord is worn, cut or damaged in any way, replace it immediately.

EXTENSION CORD LENGTH

Wire Size	A.W.G.
Up to 25 ft	18

NOTE: Using extension cords over 25 ft. long is not recommended.

OPERATION

Refer to Figures 6 and 7.

WARNING: Operation of any power tool can result in foreign objects being thrown into eyes which can result in severe eye damage. Always wear safety goggles complying with United States ANSI Z87.1 before commencing power tool operation.

CAUTION: Always observe the following safety precautions:

- Whenever adjusting or replacing any parts on the sander turn power off and remove the plug from power source.
- Recheck table knobs and bolts, they must be tightened securely.
- Make sure all guards are properly attached. All guards should be securely fastened.
- Make sure all moving parts are free and clear of any interference.
- Make sure all fasteners are tight and have not vibrated loose.
- With power disconnected, test operation by hand for clearance and adjust if necessary.

- Always wear eye protection or face shield.
- Make sure abrasive belt tracks properly. Correct tracking gives optimum performance.
- After turning switch on, always allow belt to come up to full speed before sanding or grinding.
- Be sure motor runs clockwise on disc side. Abrasive belt must travel down.
- Avoid kickback by sanding in accordance with the directional arrows.
- Keep your hands clear of abrasive belt, disc and all moving parts.
- For optimum performance do not stall motor or reduce speed. Do not force the work into the abrasive.
- Support workpiece with belt table when sanding with belt, with disc table when sanding with disc.
- Never push a sharp corner of workpiece rapidly against belt or disc. Abrasive backing may tear.
- Replace abrasives when they become loaded (glazed) or frayed.
- When grinding metal, move workpiece across abrasive to prevent heat build-up.
- Never attempt wet sanding. If work-piece becomes too hot to handle, cool it in water.

BELT INSTALLATION

Refer to Figure 6.

Sanding belt should be replaced when worn, torn, or glazed.

1. Release belt tension by pulling down on tension handle. Slide old belt off the drive and tracking wheels.
2. Pull down on the tension handle and slide new belt over the drive and tracking wheels, center belt on wheels.
3. Replace lower guard and tighten bolt.
4. Replace belt cover and knobs.
5. Rotate belt by hand to check tracking, belt should ride centered on drive and tracking wheels. Adjust socket head bolt at top of tracking bracket to track belt properly. Be sure to secure socket head bolt with hex nut.

ADJUST BELT TABLE

Refer to Figure 6.

1. To adjust belt table angle, loosen socket head bolt.
2. Tilt belt table to desired position and secure by tightening socket head bolt.

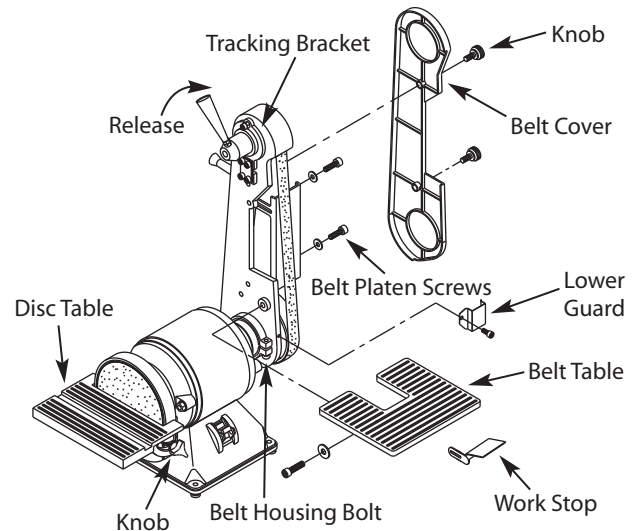

Figure 6 – Operation

OPERATION (CONTINUED)

ADJUST BELT ASSEMBLY POSITION

Refer to Figure 6, page 5.

The sanding belt assembly can be adjusted from vertical to horizontal position.

1. Loosen the belt housing bolt that clamps belt housing to motor assembly.
2. Tilt belt assembly to desired position (from vertical to horizontal). Secure belt assembly position by tightening belt housing bolt.

WORK STOP

Refer to Figure 6, page 5.

The work stop can be used instead of the belt table.

1. Remove socket head bolt and washers holding belt table on sander. Remove belt table.
2. Mount work stop to sander using the socket head bolt and washer.

NOTE: Position work stop properly so gap between work stop and belt is 1/16" or less. Tighten socket head bolt and washers.

CONTOUR SANDING

Refer to Figure 6,, page 5.

1. Belt platen can be removed for contour sanding. Remove belt cover knobs and belt cover.
2. Remove socket head bolts and washers holding platen to belt housing. Remove belt platen.
3. Replace belt cover and belt cover knobs. When contour sanding is complete, replace belt platen. Position belt platen as close to belt as possible so that platen does not contact belt.

ABRASIVE BELT FINISHING

Refer to Figure 7, page 8.

1. Finishing flat surfaces: Hold workpiece firmly with both hands, keep fingers away from abrasive belt.
Use work stop. Work stop is used to position and stabilize work. Keep end butted against workstop and move work evenly across abrasive belt. Use extra caution when finishing very thin pieces.
For finishing long pieces: remove work stop. Apply only enough pressure to allow abrasive belt to remove material.
2. Finishing curved edges: Finish outside curves on flat portion of abrasive belt. Finish inside curves on drive wheel portion of abrasive belt.
3. Finishing end grain: It is more convenient to finish ends of long workpieces with abrasive belt in a vertical position.

REPLACING ABRASIVE DISC

Refer to Figure 7, page 8.

1. Loosen and remove knobs (Ref. No. 28).
2. Gently press down on disc table and slide out disc table.
3. Remove old abrasive disc by peeling it from aluminum disc. Removing aluminum disc from motor shaft is not necessary.
4. Clean aluminum disc if necessary. Select proper abrasive disc and apply to aluminum disc.
5. Replace disc table.

ABRASIVE DISC FINISHING

1. Abrasive disc sanding is well suited for finishing small end surfaces and convex edges.
2. Move workpiece across down side (right) of face of abrasive disc.
3. Abrasive disc moves fastest and removes more material at outer edge.
4. For accuracy, use the miter gauge.

USING MITER GAUGE

Refer to Figure 7, page 8.

1. The miter gauge is used on disc table. Use the miter gauge for securing the work and holding the proper angle while sanding.
2. Adjust the angle by repositioning the protractor scale and locking it into place with knob.
3. Check accuracy of miter gauge scale.
4. Use a combination square to adjust miter gauge square to face of disc. Loosen screw and reposition indicator if necessary.

MAINTENANCE

WARNING: Make certain that the unit is disconnected from power source before attempting to service or remove any component.

CLEANING

1. Keep machine and workshop clean. Do not allow sawdust to accumulate on the belt and disc sander.
2. Keep the wheels clean. Dirt on wheels will cause poor tracking and belt slippage.
3. Operate sander with dust collector to keep dust from accumulating.

WARNING: After sanding wood or non-metallic material, always clean dust collector and guards of sawdust before grinding metal. Sparks could ignite debris and cause a fire.

4. Be certain motor is kept clean and is frequently vacuumed free of dust.
5. Use soap and water to clean painted parts, rubber parts and plastic guards.

LUBRICATION

1. The shielded ball bearings in this sander are permanently lubricated at the factory. They require no further lubrication.
2. When operation seems stiff, a light coat of automobile-type wax applied to the belt table and disc table will make it easier to feed the work while finishing.
3. Do not apply wax to the belt platen. Belt could pick up wax and deposit it on wheels causing belt to slip.

KEEP SANDER IN REPAIR

1. If power cord is worn, cut or damaged, have it replaced immediately.
2. Replace worn abrasives when needed.
3. Replace any damaged or missing parts. Use parts list to order parts.

TROUBLESHOOTING

SYMPTOM	POSSIBLE CAUSE(S)	CORRECTIVE ACTION
Motor will not start	<ol style="list-style-type: none"> 1. Blown line fuse or tripped circuit breaker 2. Low line voltage 3. Defective switch 4. Defective, blown capacitor 	<ol style="list-style-type: none"> 1. If fuse is blown, replace with fuse of proper size. If breaker tripped, reset it 2. Check power supply for voltage and correct as needed 3. Replace switch 4. Replace capacitor
Motor will not start; fuses blown or circuit breakers tripped	<ol style="list-style-type: none"> 1. Overloading due to binding 2. Defective plug 3. Defective cord 4. Defective switch 5. Motor wired for different line voltage 6. Faulty internal wiring 	<ol style="list-style-type: none"> 1. Clean around wheels and shaft and/or replace bearings 2. Replace plug 3. Replace cord 4. Replace switch 5. Rewire motors as per line voltage (See "Electrical Connections," page 4) 6. Contact authorized Dayton Service Center
Motor fails to develop full power (power output of motor decreases rapidly with decrease in voltage at motor terminals)	<ol style="list-style-type: none"> 1. Power line overloaded with lights, appliances and other motors 2. Undersized wires or circuits too long 3. General overloading of power company's facilities 	<ol style="list-style-type: none"> 1. Reduce load on power line 2. Increase wire sizes, or reduce length of wiring 3. Request a voltage check from power company
Motor overheats	Motor overloaded	Reduce load on motor
Motor stalls (resulting in blown fuses or tripped circuit breakers)	<ol style="list-style-type: none"> 1. Short circuit in motor or loose connections 2. Low voltage 3. Motor wired for different line voltage 4. Incorrect fuses or circuit breakers in power line 5. Motor overloaded 	<ol style="list-style-type: none"> 1. Inspect connections in motor for loose or shorted terminals or worn insulation on lead wires 2. Correct the low line voltage conditions 3. Rewire motor as per line voltage 4. Install correct fuses or circuit breakers (See "Electrical Connections," page 4) 5. Reduce load on motor
Machine slows down while operating	Applying too much pressure to workpiece	Ease up on pressure
Abrasive belt runs off top wheel	Not tracking properly	See "Belt Installation," page 5

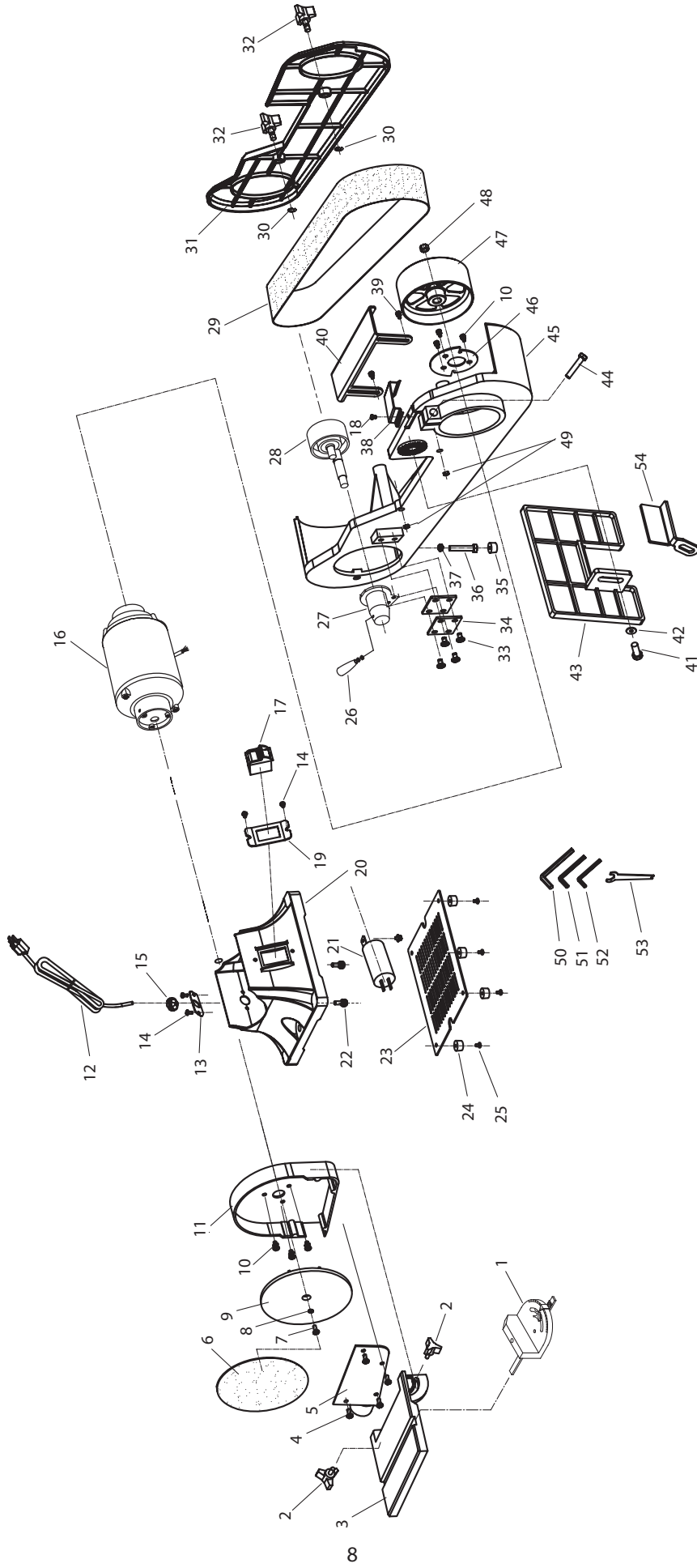

Figure 7 - Parts illustration for 2 x 6" Belt and Disc Sander.

REPLACEMENT PARTS LIST FOR 2 X 6" BELT AND DISC SANDER

Ref. No.	Description	Part No.	Qty.	Ref. No.	Description	Part No.	Qty.
1	Miter gauge assembly	9642315.01	1	29	Belt, abrasive 2 x 42" 80x	9608901.00	1
2	Disc table knob	9642316.01	2	30	Retaining ring	9642334.01	2
3	Disc table	9642317.01	1	31	Belt cover	9642335.01	1
4	Philips screw and flat washer 4 x 6mm	*	4	32	Belt tension knob	9642336.01	2
5	Dust chute	9642318.01	1	33	Philips screw, spring washer and flat washer 5 x 10mm	*	4
6	Disc paper 6" PSA	9603126.00	1	34	Spring plate	9642337.01	4
7	Hex screw	9642319.01	1	35	Support	9642338.01	1
8	Outer toothed washer 6mm dia.	*	1	36	Hex bolt 8 x 90mm	*	1
9	Disc	9642320.01	1	37	Hex nut 8mm	*	1
10	Philips screw and spring washer 5 x 10mm	*	6	38	Belt cover support	9642339.01	1
11	Disc guard	9642321.01	1	39	Hex screw and toothed washer 6 x 16mm	*	2
12	Power cord	9642322.01	1	40	Belt platen	9642340.01	1
13	Cord fixing plate	9642323.01	1	41	Hex screw 10 x 16	*	1
14	Philips screw 5 x 8mm	*	4	42	Flat washer 10mm dia.	*	1
15	Cord clip	9642324.01	1	43	Belt table	9642341.01	1
16	Motor assembly	9642325.01	1	44	Hex screw 8 x 25mm	*	1
17	Locking switch	9642326.01	1	45	Belt housing	9642342.01	1
18	Philips screw 4 x 8mm	*	1	46	Stop bracket	9642343.01	1
19	Switch plate	9642327.01	1	47	Drive wheel	9642344.01	1
20	Base	N/A	1	48	Hex nut 12mm	*	1
21	Capacitor	9642328.01	1	49	Hex nut 6mm	*	2
22	Philips screw and spring washer 6 x 20mm	*	2	50	Hex wrench 5mm	*	1
23	Base plate	9642329.01	1	51	Hex wrench 6mm	*	1
24	Rubber foot	9642330.01	4	52	Hex wrench 8mm	*	1
25	Philips screw and flat washer 4 x 12mm	*	4	53	Wrench	*	1
26	Tension handle	9642331.01	1	54	Work stop	9642345.01	1
27	Tension handle assembly	9642332.01	1	Δ	Operating Instructions & Parts Manual	9631694.01	
28	Eccentric shaft assembly	9642333.01	1				

Δ Not Shown.

* Standard hardware item available locally.

WARRANTY

Palmgren warrants their products to be free of defects in material or workmanship. This warranty does not cover defects due directly or indirectly to misuse, abuse, normal wear and tear, failure to properly maintain the product, heated, ground or otherwise altered, or used for a purpose other than that for which it was intended. The warranty does not cover expendable and/or wear parts (i.e. v-belts, coated screws, abrasives), damage to tools arising from alteration, abuse or use other than their intended purpose, packing and freight. The duration of this warranty is expressly limited to one year parts and labor, unless otherwise noted below beginning from the date of delivery to the original user. The Palmgren products carry the following warranties on parts with a 1 year warranty on labor:

- USA Machine vises – Lifetime
- IQ Machine vises – Lifetime
- Bench vises – Lifetime
- Positioning tables – Lifetime
- Bench grinders & buffers – 3 years
- Tapping machines – 3 years
- Drilling machines – 3 years
- Finishing machines – 3 years
- Band saws – 3 years
- Work stands – Lifetime
- Arbor presses – Lifetime
- Metal forming equipment – 3 years
- Accessories – 1 year

The obligation of Palmgren is limited solely to the repair or replacement, at our option, at its factory or authorized repair agent of any part that should prove deficient. Purchaser must lubricate and maintain the product under normal operating conditions at all times. Prior to operation become familiar with product and the included materials, i.e. warnings, cautions and manuals. **Failure to follow these instructions will void the warranty.**

This warranty is the purchaser's exclusive remedy against Palmgren for any deficiency in its products. Under no circumstances is Palmgren liable for any direct, indirect, incidental, special or consequential damages including lost profits in any way related to the use or inability to use our products. This warranty gives you specific legal rights which may vary from state to state.

SERVICE & REPAIR

1. If a Palmgren product requires a repair or warranty service **DO NOT** return the product to the place of purchase.
2. All warranty related work must be evaluated and approved by Palmgren.
3. Prior to returning any item the user must obtain factory approval and a valid RGA number.
4. For instructions and RGA number call toll free (800) 827-3398.