

# *Cub Cadet.*

## OPERATOR'S MANUAL

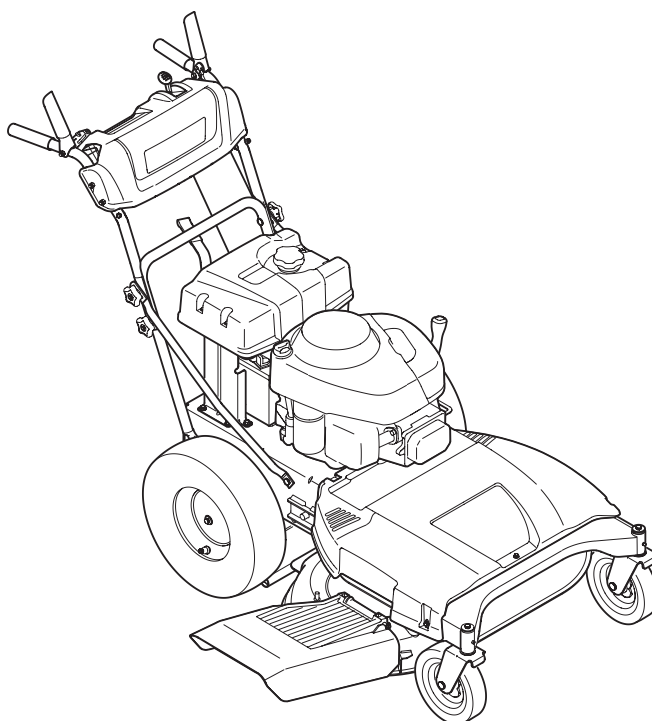

### 33" Wide Cut Mower — CC 760 & CC 760ES

#### **⚠ WARNING**

**READ AND FOLLOW ALL SAFETY RULES AND INSTRUCTIONS IN THIS MANUAL  
BEFORE ATTEMPTING TO OPERATE THIS MACHINE.  
FAILURE TO COMPLY WITH THESE INSTRUCTIONS MAY RESULT IN PERSONAL INJURY.**

---

CUB CADET LLC, P.O. BOX 361131 CLEVELAND, OHIO 44136-0019

---

## Thank You

Thank you for purchasing a Lawn Mower manufactured by Cub Cadet. It was carefully engineered to provide excellent performance when properly operated and maintained.

Please read this entire manual prior to operating the equipment. It instructs you how to safely and easily set up, operate and maintain your machine. Please be sure that you, and any other persons who will operate the machine, carefully follow the recommended safety practices at all times. Failure to do so could result in personal injury or property damage.

All information in this manual is relative to the most recent product information available at the time of printing. Review this manual frequently to familiarize yourself with the machine, its features and operation. Please be aware that this Operator's Manual may cover a range of product specifications for various models. Characteristics and features discussed and/or illustrated in this manual may not be applicable to all models. We reserve the right to change product specifications, designs and equipment without notice and without incurring obligation.

If applicable, the power testing information used to establish the power rating of the engine equipped on this machine can be found at [www.opei.org](http://www.opei.org) or the engine manufacturer's web site.

If you have any problems or questions concerning the machine, phone your local Cub Cadet dealer or contact us directly. Cub Cadet's Customer Support telephone numbers, website address and mailing address can be found on this page. We want to ensure your complete satisfaction at all times.

Throughout this manual, all references to *right* and *left* side of the machine are observed from the operating position.

The engine manufacturer is responsible for all engine-related issues with regards to performance, power-rating, specifications, warranty and service. Please refer to the engine manufacturer's Owner's/Operator's Manual, packed separately with your machine, for more information.

---

## Table of Contents

<b>Safe Operation Practices .....</b>	<b>3</b>	<b>Service .....</b>	<b>23</b>
<b>Assembly &amp; Set-Up .....</b>	<b>9</b>	<b>Troubleshooting .....</b>	<b>27</b>
<b>Controls &amp; Features.....</b>	<b>12</b>	<b>Replacement Parts .....</b>	<b>28</b>
<b>Operation.....</b>	<b>15</b>	<b>Attachments &amp; Accessories .....</b>	<b>30</b>
<b>Maintenance &amp; Adjustment .....</b>	<b>18</b>	<b>Warranty .....</b>	<b>Back Page</b>

---

## Record Product Information

Before setting up and operating your new equipment, please locate the model plate on the equipment and record the information in the provided area to the right. You can locate the model plate on the surface of the frame, on the rear of the machine. This information will be necessary, should you seek technical support via our web site or with your local Cub Cadet dealer.

### MODEL NUMBER

--	--	--	--	--	--	--	--	--	--	--	--

### SERIAL NUMBER

--	--	--	--	--	--	--	--	--	--	--	--

---

## Product Registration and Customer Support

Please register your product on our website, [www.cubcadet.com](http://www.cubcadet.com).

If you have difficulty assembling this product or have any questions regarding the controls, operation, or maintenance of this machine, you can seek help from the experts. Choose from the options below:

- ◇ Visit us on the web at [www.cubcadet.com](http://www.cubcadet.com)



See How-to Maintenance and Parts Installation Videos at [www.cubcadet.com/tutorials](http://www.cubcadet.com/tutorials)

- ◇ Locate your nearest Cub Cadet Dealer at (877) 282-8684
- ◇ Write to Cub Cadet LLC • P.O. Box 361131 • Cleveland, OH • 44136-0019



**WARNING:** This symbol points out important safety instructions which, if not followed, could endanger the personal safety and/or property of yourself and others. Read and follow all instructions in this manual before attempting to operate this machine. Failure to comply with these instructions may result in personal injury.

When you see this symbol. **HEED ITS WARNING!**

## CALIFORNIA PROPOSITION 65



**WARNING:** Engine Exhaust, some of its constituents, and certain vehicle components contain or emit chemicals known to State of California to cause cancer and birth defects or other reproductive harm.



**WARNING:** Battery posts, terminals, and related accessories contain lead and lead compounds, chemicals known to the State of California to cause cancer and reproductive harm. *Wash hands after handling.*



**DANGER:** This machine was built to be operated according to the safe operation practices in this manual. As with any type of power equipment, carelessness or error on the part of the operator can result in serious injury. This machine is capable of amputating fingers, hands, toes and feet and throwing objects. Failure to observe the following safety instructions could result in serious injury or death.

## General Operation

1. Read this operator's manual carefully in its entirety before attempting to assemble this machine. Read, understand, and follow all instructions on the machine and in the manual(s) before operation. Keep this manual in a safe place for future and regular reference and for ordering replacement parts.
2. Be completely familiar with the controls and the proper use of this machine before operating it.
3. This machine is a precision piece of power equipment, not a plaything. Therefore, exercise extreme caution at all times. This machine has been designed to perform one job: to mow grass. Do not use it for any other purpose.
4. Never allow children under 14 years of age to operate this machine. Children 14 and over should read and understand the instructions and safe operation practices in this manual and on the machine and should be trained and supervised by an adult.
5. Only responsible individuals who are familiar with these rules of safe operation should be allowed to use this machine.
6. Thoroughly inspect the area where the equipment is to be used. Remove all stones, sticks, wire, bones, toys and other foreign objects, which could be tripped over or picked up and thrown by the blade. Thrown objects can cause serious personal injury.
7. Plan your mowing pattern to avoid discharge of material toward roads, sidewalks, bystanders and the like. Also, avoid discharging material against a wall or obstruction, which may cause discharged material to ricochet back toward the operator.
8. To help avoid blade contact or a thrown object injury, stay in operator zone behind handles and keep children, bystanders, helpers and pets at least 75 feet from mower while it is in operation. Stop machine if anyone enters area.
9. Always wear safety glasses or safety goggles during operation and while performing an adjustment or repair to protect your eyes. Thrown objects which ricochet can cause serious injury to the eyes.
10. Wear sturdy, rough-soled work shoes and close-fitting slacks and shirts. Shirts and pants that cover the arms and legs and steel-toed shoes are recommended. Never operate this machine in bare feet, sandals, slippery or light-weight (e.g. canvas) shoes.
11. Do not put hands or feet near rotating parts or under the cutting deck. Contact with blade can amputate fingers, hands, toes and feet.

12. A missing or damaged discharge cover can cause blade contact or thrown object injuries.
13. Many injuries occur as a result of the mower being pulled over the foot during a fall caused by slipping or tripping. Do not hold on to the mower if you are falling; release the handle immediately.
14. Never pull the mower back toward you while you are walking. If you must back the mower away from a wall or obstruction first look down and behind to avoid tripping and then follow these steps:
  - a. Step back from mower to fully extend your arms.
  - b. Be sure you are well balanced with sure footing.
  - c. Pull the mower back slowly, no more than half way toward you.
  - d. Repeat these steps as needed.
15. Do not operate the mower while under the influence of alcohol or drugs.
16. Do not engage the self-propelled mechanism on machines so equipped while starting engine.
17. The blade control is a safety device. Never attempt to bypass its operation. Doing so makes the safety device inoperative and may result in personal injury through contact with the rotating blade. The blade control must operate easily in both directions and automatically return to the disengaged position when released.
18. Never operate the mower in wet grass. Always be sure of your footing. A slip and fall can cause serious personal injury. If you feel you are losing your footing, release the blade control handle immediately and the blade will stop rotating within three seconds.
19. Mow only in daylight or good artificial light. Walk, never run.
20. Stop the blade when crossing gravel drives, walks or roads.
21. If the equipment should start to vibrate abnormally, stop the engine and check immediately for the cause. Vibration is generally a warning of trouble.
22. Shut the engine off and wait until the blade comes to a complete stop before removing the grass catcher or unclogging the chute. The cutting blade continues to rotate for a few seconds after the blade control is released. Never place any part of the body in the blade area until you are sure the blade has stopped rotating.
23. Never operate mower without proper trail shield, discharge cover, grass catcher, blade control or other safety protective devices in place and working. Never operate mower with damaged safety devices. Failure to do so can result in personal injury.
24. Muffler and engine become hot and can cause a burn. Do not touch.
25. Never attempt to make a wheel or cutting height adjustment while the engine is running.
26. Only use parts and accessories made for this machine by the manufacturer. Failure to do so can result in personal injury.
27. When starting engine, pull cord slowly until resistance is felt, then pull rapidly. Rapid retraction of starter cord (kickback) will pull hand and arm toward engine faster than you can let go. Broken bones, fractures, bruises or sprains could result.
28. If situations occur which are not covered in this manual, use care and good judgement. Contact Customer Support for assistance or the name of the nearest service dealer.

## Slope Operation

Slopes are a major factor related to slip and fall accidents, which can result in severe injury. Operation on slopes requires extra caution. If you feel uneasy on a slope, do not mow it. For your safety, use the slope gauge included as part of this manual to measure slopes before operating this machine on a sloped or hilly area. If the slope is greater than 15 degrees, do not mow it.

### Do:

1. Mow across the face of slopes; never up and down. Exercise extreme caution when changing direction on slopes.
2. Watch for holes, ruts, rocks, hidden objects, or bumps which can cause you to slip or trip. Tall grass can hide obstacles.
3. Always be sure of your footing. A slip and fall can cause serious personal injury. If you feel you are losing your balance, release the blade control handle immediately and the blade will stop rotating within three (3) seconds.

### Do Not:

1. Do not mow near drop-offs, ditches or embankments, you could lose your footing or balance.
2. Do not mow slopes greater than 15 degrees as shown on the slope gauge.
3. Do not mow on wet grass. Unstable footing could cause slipping.

## Children

Tragic accidents can occur if the operator is not alert to the presence of children. Children are often attracted to the mower and the mowing activity. They do not understand the dangers. Never assume that children will remain where you last saw them.

1. Keep children out of the mowing area and under watchful care of a responsible adult other than the operator.
2. Be alert and turn mower off if a child enters the area.
3. Before and while moving backwards, look behind and down for small children.
4. Use extreme care when approaching blind corners, doorways, shrubs, trees, or other objects that may obscure your vision of a child who may run into the mower.
5. Keep children away from hot or running engines. They can suffer burns from a hot muffler.
6. Never allow children under 14 years of age to operate this machine. Children 14 and over should read and understand the instructions and safe operation practices in this manual and on the machine and be trained and supervised by an adult.

## Service

### Safe Handling Of Gasoline:

1. To avoid personal injury or property damage use extreme care in handling gasoline. Gasoline is extremely flammable and the vapors are explosive. Serious personal injury can occur when gasoline is spilled on yourself or your clothes, which can ignite. Wash your skin and change clothes immediately.
2. Use only an approved gasoline container.
3. Never fill containers inside a vehicle or on a truck or trailer bed with a plastic liner. Always place containers on the ground away from your vehicle before filling.
4. Remove gas-powered equipment from the truck or trailer and refuel it on the ground. If this is not possible, then refuel such equipment on a trailer with a portable container, rather than from a gasoline dispenser nozzle.
5. Keep the nozzle in contact with the rim of the fuel tank or container opening at all times until fueling is complete. Do not use a nozzle lock-open device.
6. Extinguish all cigarettes, cigars, pipes and other sources of ignition.
7. Never fuel machine indoors because flammable vapors will accumulate in the area.
8. Never remove gas cap or add fuel while engine is hot or running. Allow engine to cool at least two minutes before refueling.
9. Never over fill fuel tank. Fill tank to no more than 1 inch below bottom of filler neck to provide for fuel expansion.
10. Replace gasoline cap and tighten securely.
11. If gasoline is spilled, wipe it off the engine and equipment. Move machine to another area. Wait 5 minutes before starting engine.
12. Never store the machine or fuel container near an open flame, spark or pilot light as on a water heater, space heater, furnace, clothes dryer or other gas appliances.
13. To reduce fire hazard, keep machine free of grass, leaves, or other debris build-up. Clean up oil or fuel spillage and remove any fuel soaked debris.
14. Allow machine to cool at least 5 minutes before storing.
3. Check the blade and engine mounting bolts at frequent intervals for proper tightness. Also, visually inspect blade for damage (e.g., bent, cracked, worn) Replace blade with the original equipment manufacturer's (O.E.M.) blade only, listed in this manual. "Use of parts which do not meet the original equipment specifications may lead to improper performance and compromise safety!"
4. Mower blades are sharp and can cut. Wrap the blade or wear gloves, and use extra caution when servicing them.
5. Keep all nuts, bolts, and screws tight to be sure the equipment is in safe working condition.
6. Never tamper with safety devices. Check their proper operation regularly.
7. After striking a foreign object, stop the engine, disconnect the spark plug wire and ground against the engine. Thoroughly inspect the mower for any damage. Repair the damage before starting and operating the mower.
8. Never attempt to make a wheel or cutting height adjustment while the engine is running.
9. Grass catcher components, discharge cover, and trail shield are subject to wear and damage which could expose moving parts or allow objects to be thrown. For safety protection, frequently check components and replace immediately with original equipment manufacturer's (O.E.M.) parts only, listed in this manual. "Use of parts which do not meet the original equipment specifications may lead to improper performance and compromise safety!"
10. Do not change the engine's governor setting or over-speed the engine. The governor controls the maximum safe operating speed of the engine.
11. Check fuel line, tank, cap, and fittings frequently for cracks or leaks. Replace if necessary.
12. Do not crank engine with spark plug removed.
13. Maintain or replace safety and instruction labels, as necessary.
14. Observe proper disposal laws and regulations. Improper disposal of fluids and materials can harm the environment.
15. According to the Consumer Products Safety Commission (CPSC) and the U.S. Environmental Protection Agency (EPA), this product has an *Average Useful Life* of seven (7) years, or 140 hours of operation. At the end of the *Average Useful Life* have the machine inspected annually by an authorized service dealer to ensure that all mechanical and safety systems are working properly and not worn excessively. Failure to do so can result in accidents, injuries or death.

### General Service:

1. Never run an engine indoors or in a poorly ventilated area. Engine exhaust contains carbon monoxide, an odorless and deadly gas.
2. Before cleaning, repairing, or inspecting, make certain the blade and all moving parts have stopped. Disconnect the spark plug wire and ground against the engine to prevent unintended starting.

### Do not modify engine

To avoid serious injury or death, do not modify engine in any way. Tampering with the governor setting can lead to a runaway engine and cause it to operate at unsafe speeds. Never tamper with factory setting of engine governor.

## Notice Regarding Emissions

Engines which are certified to comply with California and federal EPA emission regulations for SORE (Small Off Road Equipment) are certified to operate on regular unleaded gasoline, and may include the following emission control systems: Engine Modification (EM), Oxidizing Catalyst (OC), Secondary Air Injection (SAI) and Three Way Catalyst (TWC) if so equipped.

## Spark Arrestor











**WARNING:** This machine is equipped with an internal combustion engine and should not be used on or near any unimproved forest-covered, brush covered or grass-covered land unless the engine's exhaust system is equipped with a spark arrestor meeting applicable local or state laws (if any).

If a spark arrestor is used, it should be maintained in effective working order by the operator. In the State of California the above is required by law (Section 4442 of the California Public Resources Code). Other states may have similar laws. Federal laws apply on federal lands.

A spark arrestor for the muffler is available through your nearest engine authorized service dealer or contact the service department, P.O. Box 361131 Cleveland, Ohio 44136-0019.

## Safety Symbols

This page depicts and describes safety symbols that may appear on this product. Read, understand, and follow all instructions on the machine before attempting to assemble and operate.

Symbol	Description
	<b>READ THE OPERATOR'S MANUAL(S)</b> Read, understand, and follow all instructions in the manual(s) before attempting to assemble and operate.
	<b>DANGER — ROTATING BLADES</b> To reduce the risk of injury, keep hands and feet away. Do not operate unless discharge cover or grass catcher is in its proper place. If damaged, replace immediately.
	<b>DANGER — BYSTANDERS</b> Do not mow when children or others are around.
	<b>DANGER — HAND/ FOOT CUT</b> Keep hands and feet away from rotating parts.
	<b>DANGER — THROWN DEBRIS</b> Remove objects that can be thrown by the blade in any direction. Wear safety glasses.
	<b>DANGER — SLOPES</b> Use extra caution on slopes. Do not mow slopes greater than 15°.
	<b>WARNING—GASOLINE IS FLAMMABLE</b> Allow the engine to cool at least two minutes before refueling.
	<b>WARNING— CARBON MONOXIDE</b> Never run an engine indoors or in a poorly ventilated area. Engine exhaust contains carbon monoxide, an odorless and deadly gas.
	<b>WARNING— HOT SURFACE</b> Engine parts, especially the muffler, become extremely hot during operation. Allow engine and muffler to cool before touching.



**WARNING:** Your Responsibility—Restrict the use of this power machine to persons who read, understand and follow the warnings and instructions in this manual and on the machine.

**SAVE THESE INSTRUCTIONS!**

## Slope Gauge

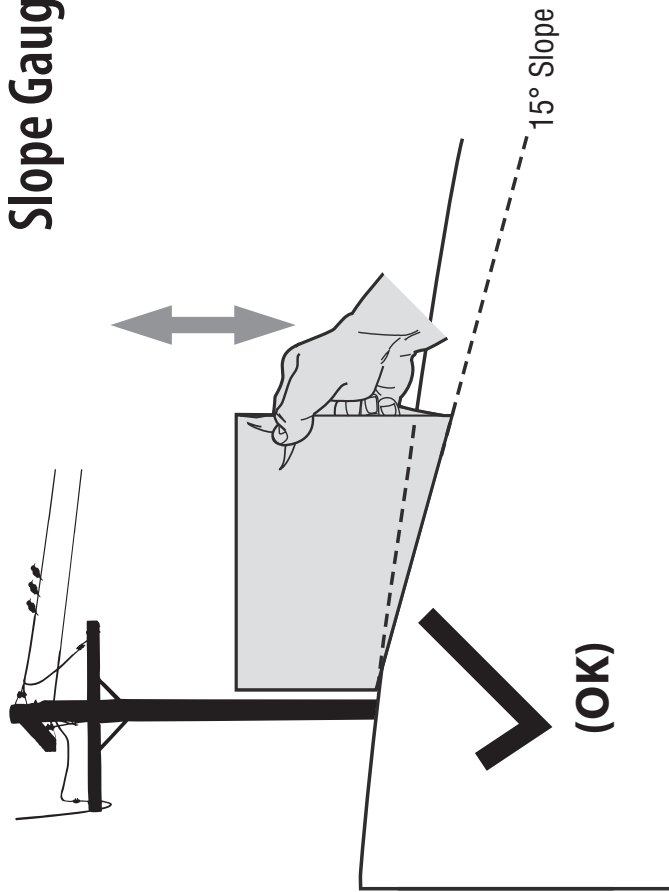

Figure 1

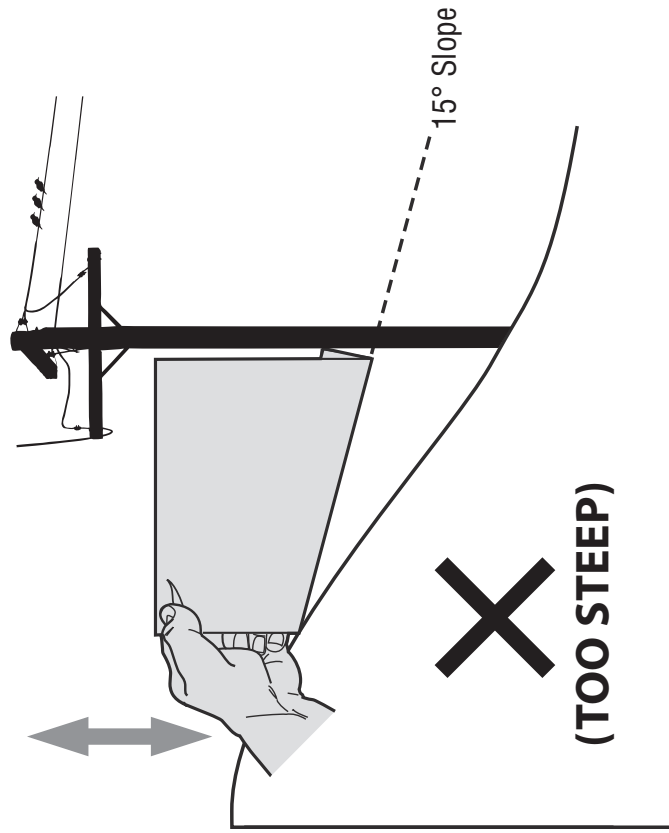

Figure 2

*15° dashed line*

### USE THIS SLOPE GAUGE TO DETERMINE IF A SLOPE IS TOO STEEP FOR SAFE OPERATION!

To check the slope, proceed as follows:

1. Remove this page and fold along the dashed line.
2. Locate a vertical object on or behind the slope (e.g. a pole, building, fence, tree, etc.)
3. Align either side of the slope gauge with the object (See Figure 1 and Figure 2).
4. Adjust gauge up or down until the left corner touches the slope (See Figure 1 and Figure 2).
5. If there is a gap below the gauge, the slope is too steep for safe operation (See Figure 2 above).



**WARNING!** Slopes are a major factor related to tip-over and roll-over accidents which can result in severe injury or death. Do not operate machine on slopes in excess of 15 degrees. All slopes require extra caution.

Always mow across the face of slopes, never up and down slopes.



## Contents of Crate

- One Lawn Mower
- One Oil Drain Tube
- One Deck Wash Hose Coupler
- One Lawn Mower Operator's Manual
- One Engine Operator's Manual

## Mower Set-Up

### Shipping Brace Removal



**WARNING!** Make sure the lawn mower's engine is off. Remove the ignition key (if so equipped) before removing the shipping brace.

1. Locate the shipping brace, if present, found on the right side of the cutting deck. See Figure 3-1.

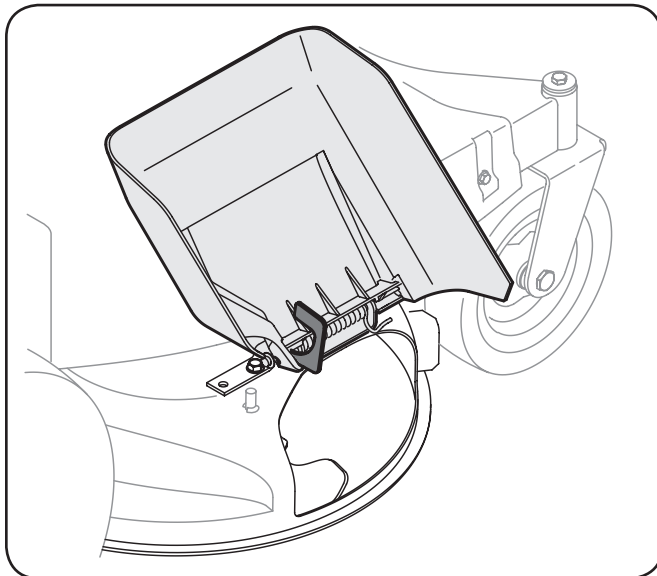

**Figure 3-1**

2. While holding the discharge chute with your left hand, remove the shipping brace with your right hand by grasping it between your thumb and index finger and rotating it clockwise.



**WARNING!** The shipping brace is used for packaging purposes only. Remove and discard the shipping brace before operating your lawn mower.



**WARNING!** The mowing deck is capable of throwing objects. Failure to operate the mower without the discharge cover in the proper operating position could result in serious personal injury and/or property damage.

### Attaching the Battery Cables (for Electric Start Models)

**NOTE:** The positive battery terminal is marked Pos. (+). The negative battery terminal is marked Neg. (-).

1. Attach the red cable to the positive(+) battery terminal and the black cable to the negative(-) battery terminal with the bolts and hex nuts provided. See Figure 3-2.

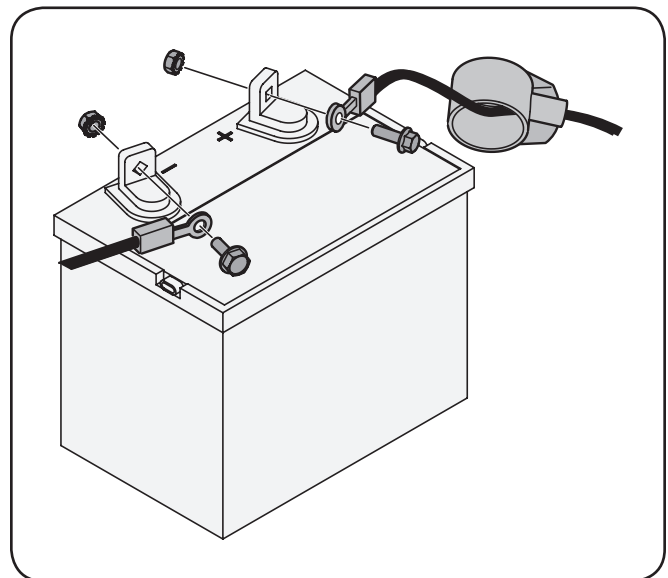

**Figure 3-2**

2. Make certain the hold-down rod is in position over the battery, securing it in place and make certain that the red rubber boot covers the positive battery terminal to help protect it from corrosion.

**NOTE:** If the battery is put into service after the date shown on top/side of battery, charge the battery as instructed in the Maintenance section of this manual prior to operating the mower.

## Unfolding the Handle

1. Remove the star knobs and carriage screws from the lower handle. See Figure 3-3.

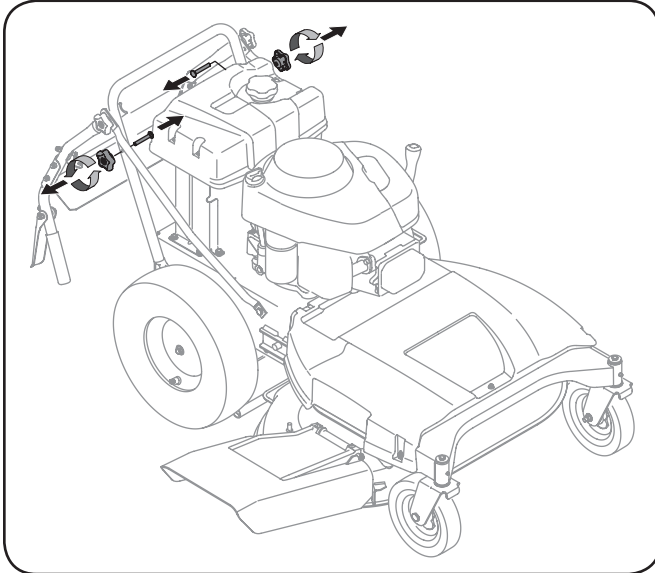

**Figure 3-3**

2. Pivot the upper handle into operating position. Be careful not to crimp cables. See Figure 3-4.

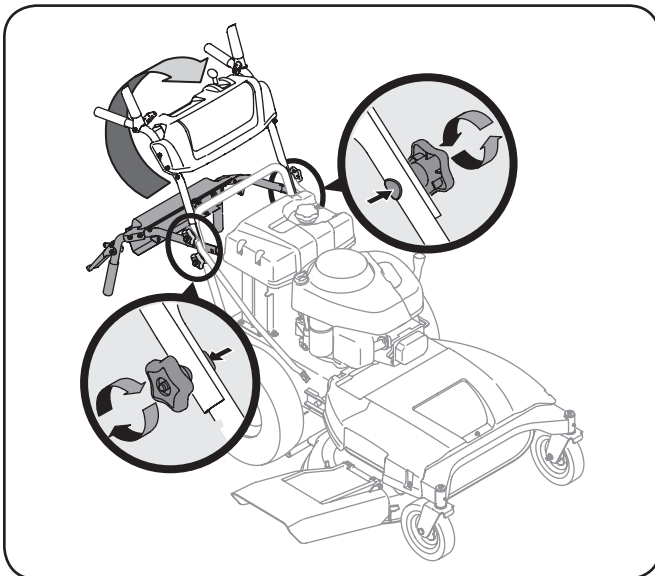
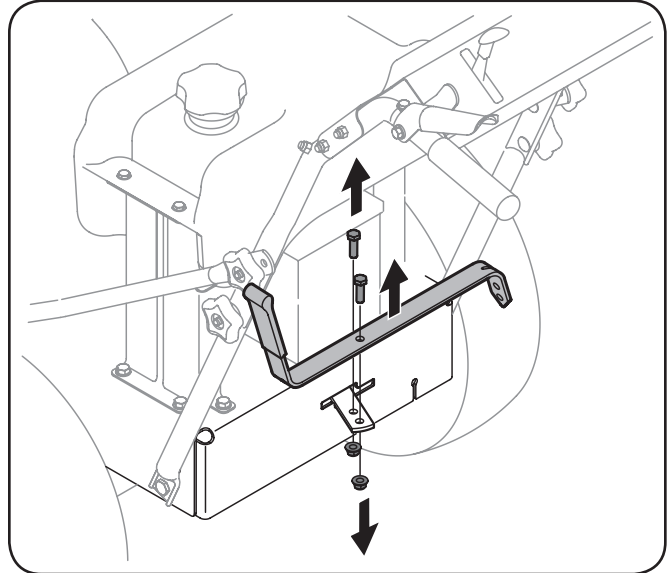

**Figure 3-4**

3. Reinstall the carriage screws and knobs removed earlier.
4. Tighten the upper and lower star knobs and carriage screws to secure the upper handle to the lower handle. See Figure 3-4.
5. The handle height can be adjusted to any of three positions. For instructions, refer to Handle Height in the Maintenance and Adjustments section of this manual.

## Attaching the Shift Lever

1. Remove the screw and the lock nut that secures the shift lever to the shift lever plate. See Figure 3-5.



**Figure 3-5**

2. Remove the remaining screw and nut from the lower shift lever plate. See Figure 3-5.
3. Position the upper shift lever into a vertical position aligning the holes in the lever with the holes in the shift plate. See Figure 3-6.

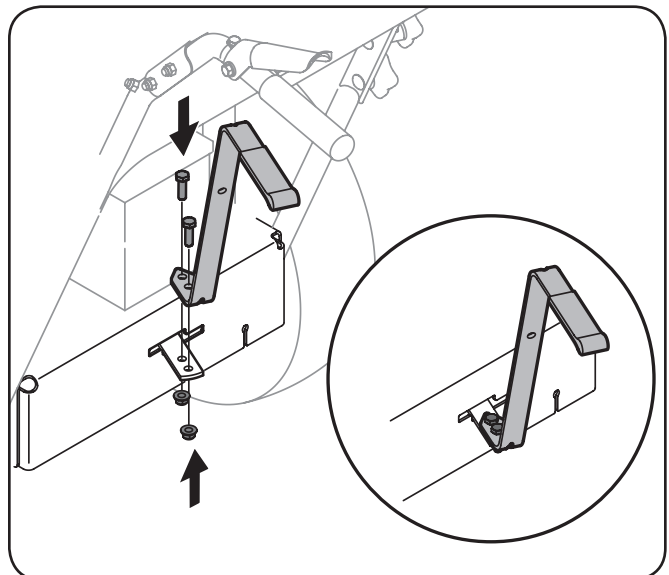

**Figure 3-6**

4. Secure the lever to the plate using the two screws and two nuts removed earlier. See Figure 3-6 inset.

## Checking Tire Pressure



**WARNING!** Under any circumstance do not exceed manufacturer's recommended psi. Equal tire pressure should be maintained at all times. Refer to sidewall of tire for recommended pressure.

The rear tires on your unit may be over-inflated for shipping purposes. Reduce the tire pressure before operating the mower. Refer to the tire side wall for tire manufacturer's recommended psi and deflate (or inflate) the tires as necessary.

## Gas and Oil

The fuel tank has a capacity of two gallons. Remove the fuel cap by turning it counterclockwise. Use only clean, fresh (no more than 30 days old), unleaded gasoline. Fill the tank no higher than four inches below the top of the filler neck to allow space for fuel expansion.



**WARNING!** Use extreme care when handling gasoline. Gasoline is extremely flammable and the vapors are explosive. Never fuel the machine indoors or while the engine is hot or running. Extinguish cigarettes, cigars, pipes and other sources of ignition.

**NOTE:** Your lawn mower is shipped with oil in the engine. However, you **MUST** check the oil level before operating.



**CAUTION:** Always check the engine oil level before each use as instructed in the Engine Owner's Manual. Add oil as necessary. Failure to do so may result in serious damage to your engine.

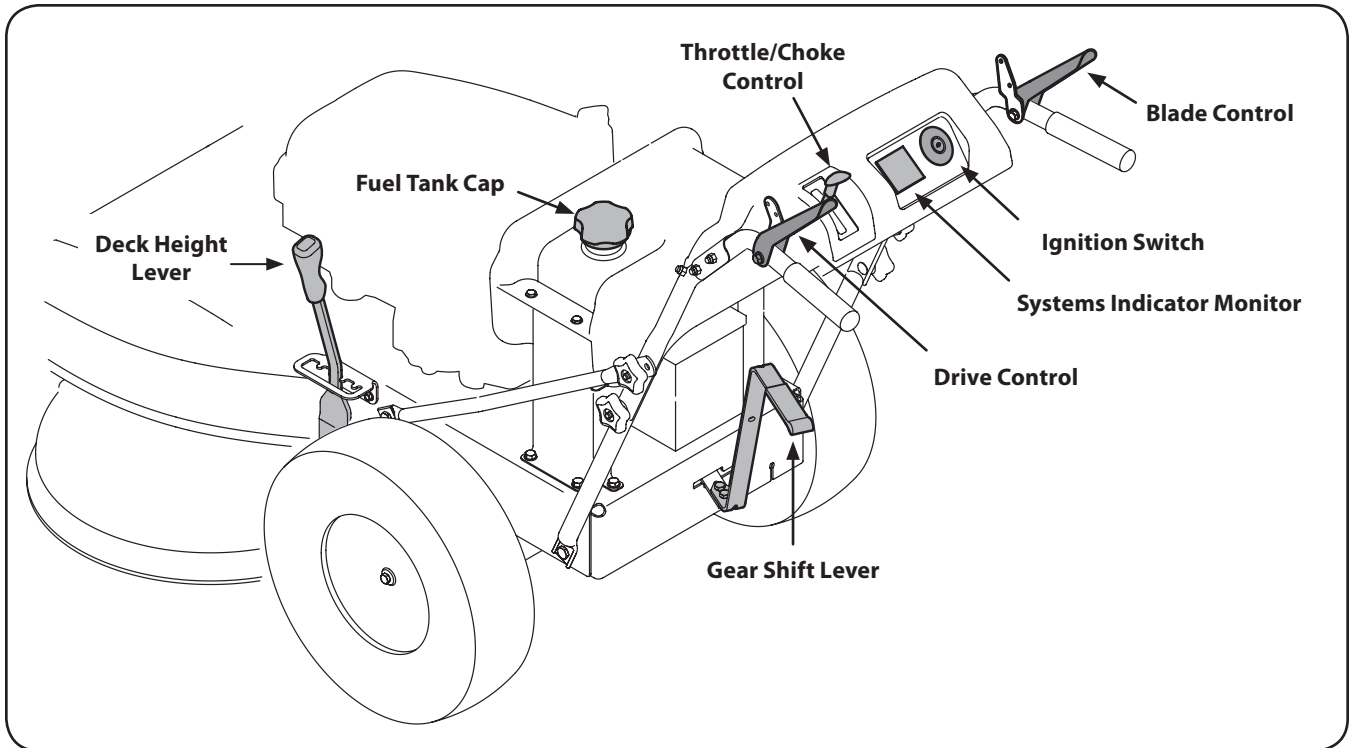

**Figure 4-1**

Lawn Mower controls and features are illustrated in Figure 4-1 and described on the following pages.



**WARNING!** Read and follow all safety rules and instructions in this manual, including the entire Operation section, before attempting to operate this machine. Failure to comply with all safety rules and instructions may result in personal injury.

## Throttle / Choke Control

**Note:** When operating the mower with the cutting deck engaged, be certain that the throttle/choke control is in the fast position.

The throttle / choke control is used to adjust engine speeds, to activate the engine choke and to stop the engine. Always run engine with the throttle / choke control lever in the fast position for best mower performance.

**Choke:** Use when starting a cold engine

**Fast:** Use during mower operation.

**Slow:** Use when idling engine.

**Stop:** Stops the engine. (Non-electric start units only).

Refer to Starting The Engine in the Operation section of this manual for detailed starting instructions.

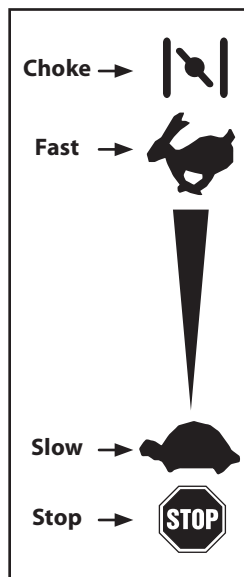

## Engine

Refer to the Engine Owner's Manual for details regarding all engine-related controls and features.

## Deck Height Lever

Use this lever to adjust the mowing deck's cutting height. To use, move the lever to the left, then place the lever in the notch best suited for your application.



## Ignition Switch (Electric Start Models Only)



**WARNING!** Never leave a running machine unattended. Always disengage blades, stop engine and remove key to prevent unintended starting.

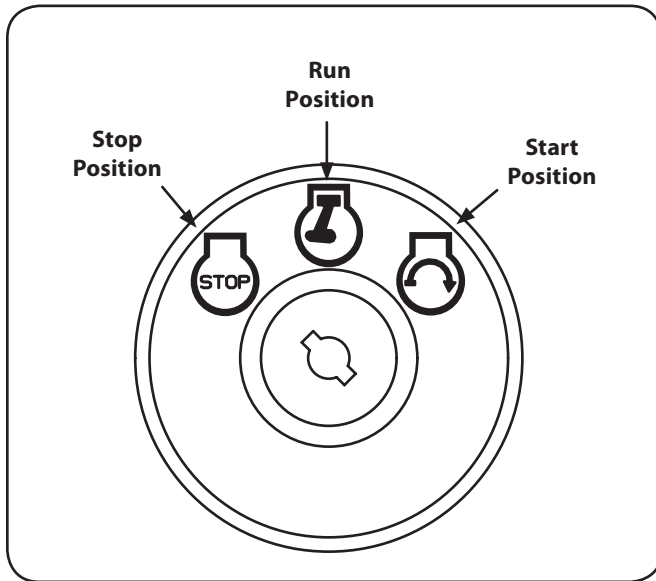

Figure 4-2

The three-position switch is used to start and stop the engine on electric-start models. See Figure 4-2. To start the engine, insert the key into the ignition switch and turn clockwise to the **START** position. Release key into the **RUN** position once the engine has started. Turn the key to **STOP** to stop the engine.



**CAUTION:** Never move the key into the Start position while the engine is running; doing so may cause damage to the engine's starter.

## Drive Control

The drive control is used to engage and disengage drive to the wheels. To engage this control, squeeze the drive control against the handlebar grip. To stop the drive, release the drive control.



**CAUTION:** Always release the drive control before changing speeds. Failure to do so may result in serious damage to your transmission.

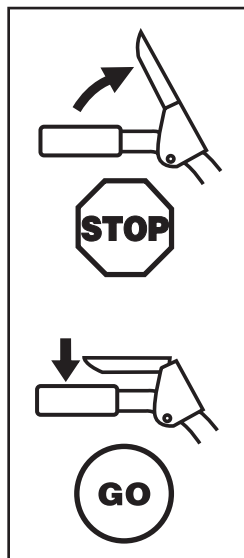

## Blade Control

Located on the right-hand handle, the blade control is used to engage the mowing deck. To operate, press and hold the lever against the handlebar grip. To stop the blades, release the blade control.

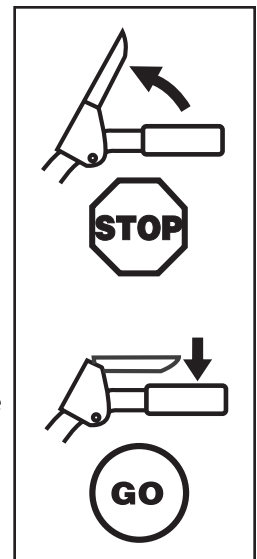

**WARNING!** Never attempt to start the engine with the blade control engaged.



**CAUTION:** Always release the blade control when starting the engine. Failure to do so may result in premature wear to your engine's electric starter.

## Gear Shift Lever

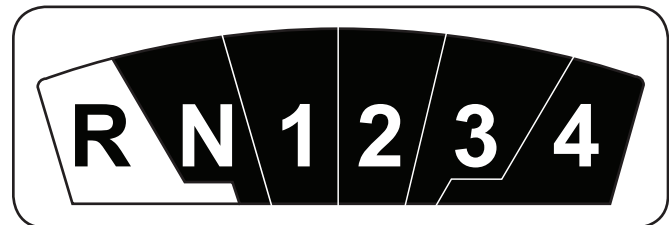

Use this lever to select any of four forward ground speeds, neutral, or reverse.

### Forward

Four forward speeds are available. Position one (1) is the slowest and position four (4) is the fastest.

### Reverse

To select reverse, put the lever in the Reverse (R) position.



**WARNING:** Look behind the mower before and during reverse operation. Stop the mower blades before operating in reverse.

### Neutral

Place the lever in neutral (N) before starting the mower, and when the mower is not in use. In addition, the mower can be manually pushed or pulled by placing the gear shift lever into N (neutral) position and pressing the drive control against the handlebar grip.



**CAUTION:** Always release the drive control before changing speeds. Failure to do so may result in serious damage to your transmission.

## Systems Indicator Monitor / Hour Meter (Electric Start Models Only)

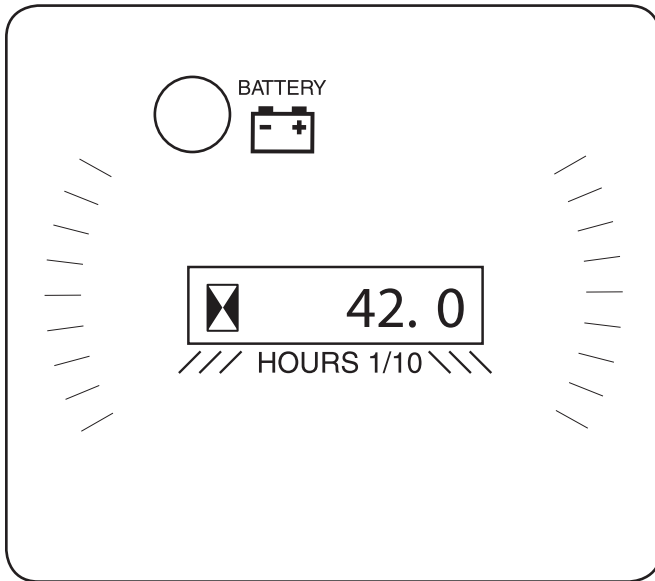

### LCD

When the ignition key is rotated out of the STOP position but not into the START position, the systems indicator monitor displays the battery's output, in volts, on its LCD for approximately five seconds, after which it displays an hour glass and the hours of mower operation. Once the engine is started, the monitor continually displays an hour glass and the hours of mower operation on its LCD.

**NOTE:** Hours of mower operation are recorded any time the ignition key is rotated out of the STOP position, regardless of whether the engine is started.

The Indicator Monitor will also remind the operator of maintenance intervals for changing the engine oil. The LCD will alternately flash the recorded hours, "CHG" and "OIL" for five minutes, after every 50 hours of recorded operation elapse. The maintenance interval lasts for two hours (from 50-52, 100-102, 150-152, etc.). The LCD will also flash as described above for five minutes every time the mower's engine has been started during this maintenance interval. Before the interval expires, change the engine oil as instructed in the Maintenance section of this Operator's Manual.

### Battery (Electric Start Models Only)

It is normal for the Battery light to illuminate while the engine is cranking during start-up, but if it illuminates during operation, while the engine is running, the battery is in need of a charge or the engine's charging system is not generating sufficient amperage. Charge the battery as instructed in the Service section of this manual or have the charging system checked by your Cub Cadet dealer.

## Starting the Engine

### For Mowers Equipped with Electric Start

Refer to the Set-Up and Assembly section of this manual for Gasoline and Oil fill-up instructions.

1. Release all controls on the mower.
2. Move the gear shift lever into the neutral (N) position.
3. Insert the key into the ignition switch.
4. If starting a cold engine, place the throttle/choke control all the way forward, into the CHOKE position. If restarting a warm engine, place the throttle/choke control into the FAST (rabbit) position.
5. Turn the ignition key clockwise to the START position. After the engine starts, release the key. It will return to the RUN position.



**CAUTION:** Do NOT hold the key in the START position for longer than five seconds at a time. Doing so may cause damage to your engine's electric starter.

6. Move the throttle/choke control into the FAST (rabbit) position.

**NOTE:** Never leave the throttle/choke control in the CHOKE while operating the mower. Doing so will result in a "rich" fuel mixture and cause the engine to run poorly.

### For Mowers Equipped with Recoil Start

Refer to the Set-Up and Assembly section of this manual for Gasoline and Oil fill-up instructions.

1. Release all controls on the mower.
2. Move the gear shift lever into the neutral (N) position.
3. Move the throttle/choke control lever fully upward to the CHOKE position to start a cold engine or to FAST (rabbit) position to start a warm engine.
4. Grasp starter rope handle and pull slowly until rope pulls slightly harder. Let rope rewind slowly. Then pull rope with a rapid, full arm stroke. Let rope return slowly. If engine fails to start after three pulls, repeat instructions (try setting throttle at fast setting).
5. Move the throttle/choke control into the FAST (rabbit) position.

**NOTE:** Never leave the throttle/choke control in the CHOKE while operating the mower. Doing so will result in a "rich" fuel mixture and cause the engine to run poorly.

## Stopping the Engine



**WARNING!** If you strike a foreign object, stop the engine and remove the ignition key (if so equipped). Thoroughly inspect the machine for any damage. Repair the damage before restarting and operating.

1. If the blades are engaged, release the Blade Control.
2. Move the throttle/choke control into the STOP position.
3. Turn the ignition key counterclockwise to the STOP position for electric start models.
4. Remove the key from the ignition switch to prevent unintended starting for electric start models.

## Engaging the Drive



**WARNING!** Avoid sudden starts, excessive speed and sudden stops.

1. Start the engine as instructed earlier in this section and move the throttle/choke control into the FAST (rabbit) position.
2. To travel FORWARD:
  - a. Place the gear shift lever in any of the four forward ground speeds. Select a speed appropriate for the conditions and a pace you're comfortable with.
  - b. Slowly squeeze the Drive Control against the left handle grip and the mower will move. Release it and drive motion will stop.

To travel in REVERSE:

- a. Check that the area behind is clear.
- b. Place the gear shift lever in Reverse (R).
- c. Slowly squeeze the Drive Control against the left handle grip and the mower will move. Release it and drive motion will stop.



**CAUTION:** Do NOT attempt to change the direction of travel when the mower is in motion. Always release the drive control and bring the mower to a complete stop before repositioning the gear shift lever from a forward gear into Reverse. Failure to do so may result in serious damage to your transmission.



**WARNING!** Do not leave the operator's position without first releasing the Blade Control. If leaving the mower unattended, also turn the engine off and remove the ignition key (if so equipped).

## Engaging the Blades



**WARNING!** To help avoid blade contact or a thrown object injury, keep bystanders, helpers, children and pets at least 75 feet from the machine while it is in operation. Stop machine if anyone enters the area.

1. Move the throttle/choke control to the FAST (rabbit) position.
2. Slowly squeeze the Blade Control against the right handle grip and the blades will engage. Release it and the blades will stop.

## Operating On Slopes

Refer to the SLOPE GAUGE on page 8 to help determine slopes where you may operate the mower safely.



**WARNING!** Do not mow on inclines with a slope in excess of 15 degrees (a rise of approximately 2-1/2 feet every 10 feet). The mower could overturn and cause serious injury.

- Mow across the face of slopes; never up and down.
- Exercise extreme caution when changing direction on slopes.
- Watch for holes, ruts, rocks, hidden objects, or bumps which can cause you to slip or trip. Tall grass can hide obstacles.
- Always be sure of your footing. A slip and fall can cause serious personal injury. If you feel you are losing your balance, release the blade control handle immediately and the blade will stop rotating within three (3) seconds:
- Do not mow near drop-offs, ditches or embankments, you could lose your footing or balance.
- Do not mow slopes greater than 15 degrees as shown on the slope gauge.
- Do not mow on wet grass. Unstable footing could cause slipping.

## Using the Deck Height Lever

To raise or lower the cutting deck, move the deck height lever to the left, then place it in the notch best suited for your application.

## Mowing

The following information will be helpful when operating your mower.



**WARNING!** Plan your mowing pattern to avoid discharge of materials toward roads, sidewalks, bystanders and the like. Also, avoid discharging material against a wall or obstruction which may cause discharged material to ricochet back toward the operator.

- Do not mow at fast ground speeds, especially if a mulch kit or grass collector is installed.
- Do not cut the grass too short. Short grass is prone to weed growth and yellows quickly in dry weather.
- Always operate the mower with the throttle/choke control in the FAST (rabbit) position while mowing
- For best results, it is recommended that the first two laps be cut with the discharge thrown towards the center. After the first two laps, reverse the direction to throw the discharge to the outside for the balance of cutting. This will give a better appearance to the lawn.
- Do NOT attempt to mow heavy brush and weeds or extremely tall grass. Your mower is designed to mow lawns, NOT clear brush.
- Keep the blades sharp and replace the blades when worn.



**WARNING!** After striking a foreign object, stop the engine, disconnect the spark plug wire and ground against the engine. Thoroughly inspect the mower for any damage. Always inspect the blade timing belt as instructed in the Maintenance section of this manual. Repair the damage before starting and operating the mower.

## Mulching

The Cub Cadet Wide Cut mower is equipped with a mulch kit which incorporates special blades, already standard on your mower, in a process of recirculating grass clippings repeatedly beneath the cutting deck. The ultra-fine clippings are then forced back into the lawn where they act as a natural fertilizer. Observe the following points for the best results when mulching.

- Never attempt to mulch if the lawn is damp. Wet grass tends to stick to the underside of the cutting deck preventing proper mulching of the clippings.
- Do NOT attempt to mulch more than 1/3 the total height of the grass. Doing so will cause the clippings to clump up beneath the deck and not be mulched effectively.
- Maintain a slow ground speed to allow the grass clippings more time to effectively be mulched.
- Always keep the throttle control lever in the FAST (rabbit) position while mowing. Failing to keep the engine at full throttle places strain on the mower's engine and does not allow the blades to properly mulch the grass clippings.



## Installing / Removing Mulch Baffle



**WARNING!** Before installing or removing the mulch plug, disengage blades, stop the engine and remove key if so equipped to prevent unintended starting.

Stop the engine and wait for all parts to stop moving.

### Installing the Mulch Baffle

1. Insert the right-side tab (A) of the baffle into the bracket on the deck. See Figure 5-1.

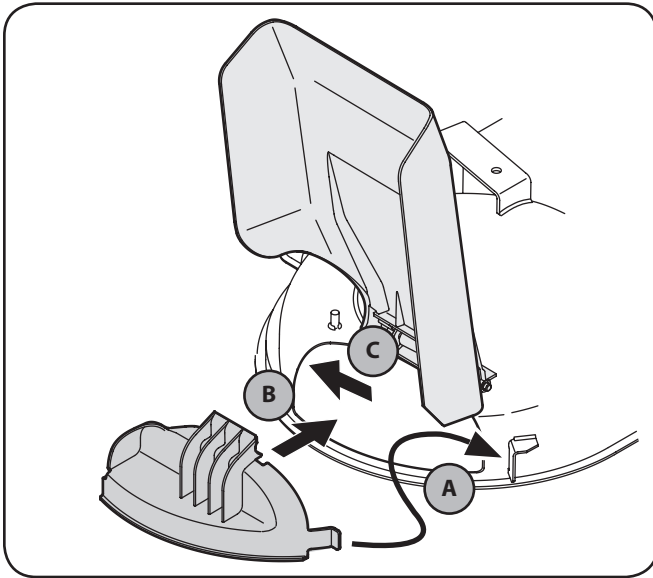

**Figure 5-1**

2. Insert the mulch baffle into the discharge opening (B), See Figure 5-1.
3. Once it's positioned in the deck opening, push the baffle towards the rear of the mower (C) to secure it in place. See Figure 5-1.

### Removing the Mulch Baffle

Slide the baffle to the right (toward the front of the mower) to disengage the slot from the mower deck and then pry the left-side of the baffle outward.

## Maintenance



**WARNING!** Before performing any maintenance or repairs, disengage blades, stop engine and remove key if so equipped to prevent unintended starting.

## Engine

Refer to the Engine Owner's Manual for all engine maintenance procedures and specific instructions pertaining to your engine. For illustrative purposes, the Briggs & Stratton engine is shown in the figures below.

**NOTE:** Maintenance, repair, or replacement of the emission control devices and systems which are being done at owner's expense may be performed by any engine repair establishment or individual. **Warranty repairs must be performed by a Cub Cadet Dealer.**

## Changing the Engine Oil



**WARNING!** If the engine has been recently run, the engine, muffler and surrounding metal surfaces will be hot and can cause burns to the skin. Exercise caution to avoid burns.

1. Run the engine for a few minutes to allow the oil in the crankcase to warm up. Warm oil will flow more freely and carry away more of the engine sediment which may have settled at the bottom of the crankcase. Use care to avoid burns from hot oil.
2. Remove the upper star knob and carriage screw on the right side of the handle. See Figure 6-1.

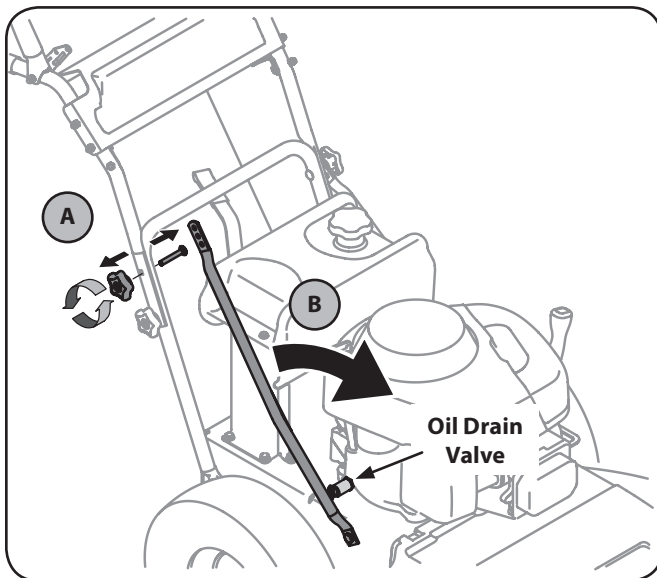

Figure 6-1

3. Pivot the support tube forward to allow room to connect the oil drain hose to the oil drain valve. See Figure 6-1.

4. Pop open the protective cap on the end of the oil drain valve to expose the drain port. See Figure 6-2.

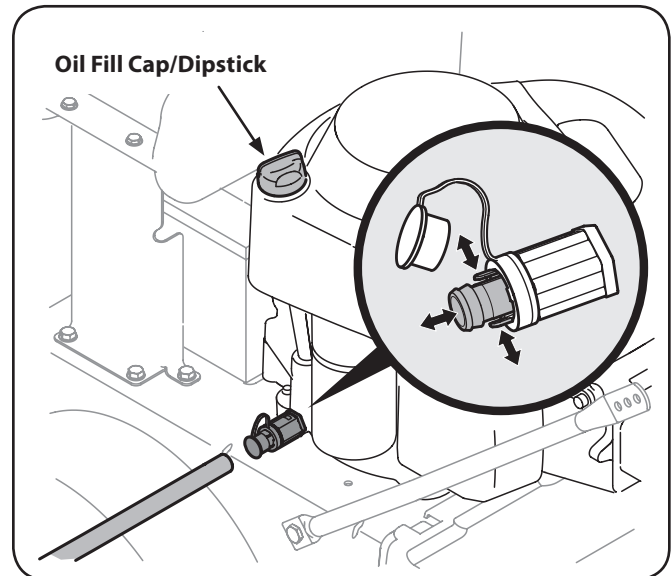

Figure 6-2

5. Remove the oil fill cap/dipstick from the oil fill tube.
6. Push the oil drain hose (packed with this manual) onto the oil drain port. Route the opposite end of the hose into an appropriate oil collection container with at least a 2.5 quart capacity, to collect the used oil.
7. Pinch the tabs on the oil drain valve, then pull outward to begin draining oil. See Figure 6-2.
8. After the oil has finished draining, push the end of the oil drain valve back in, until the tabs click into place. Re-cap the end of the oil drain valve to keep debris from entering the drain port.
9. Refill the engine with new oil. Refer to the Engine Owner's Manual for information regarding the volume and weight of engine oil.

## Air Cleaner

Service the pre-cleaner and cartridge/air cleaner element as instructed in the Engine Owner's Manual.

## Spark Plug

The spark plug should be cleaned and the gap reset once a season. Refer to the Engine Owner's Manual for correct plug type and gap specifications.

## Battery (Electric Start Models Only)



**CALIFORNIA PROPOSITION 65 WARNING!** Battery posts, terminals, and related accessories contain lead and lead compounds, chemicals known to the State of California to cause cancer and reproductive harm. Wash hands after handling.

The battery is sealed and is maintenance-free. Acid levels cannot be checked and fluid can not be added.

- Always keep the battery cables and terminals clean and free of corrosive build-up.
- After cleaning the battery and terminals, apply a light coat of petroleum jelly or grease to both terminals.



**CAUTION:** If removing the battery for cleaning, disconnect the NEGATIVE (Black) wire from its terminal first, followed by the POSITIVE (Red) wire. When reinstalling the battery, always connect the POSITIVE (Red) wire its terminal first, followed by the NEGATIVE (Black) wire. Be certain that the wires are connected to the correct terminals; reversing them could result in serious damage to your engine's alternating system.

## Tire Pressure



**WARNING!** Warning! Under any circumstance do not exceed manufacturer's recommended psi. Equal tire pressure should be maintained at all times. Refer to sidewall of tire for recommended pressure.

Periodically check the pressure on both your mower's rear tires. Uneven tire pressure will cause the cutting deck to mow unevenly and may result in mower to veering to either the left or right during operation. Refer to the tire side wall for tire manufacturer's recommended psi and deflate (or inflate) the tires as necessary.

## Cleaning the Mower

Any fuel or oil spilled on the machine should be wiped off promptly. Do NOT allow debris to accumulate around the cooling fins of the engine, the transmission's cooling fan or on any other part of the machine, especially the belts and pulleys.

### Smart Jet

Your mower's deck is equipped with a water port on its surface as part of its deck wash system.

Use the Smart Jet to rinse grass clippings from the deck's underside and prevent the buildup of corrosive chemicals.

Complete the following steps AFTER EACH MOWING:



**WARNING!** Before using the deck wash system, always disengage the Blade Control, stop engine and remove key to prevent unintended starting.

1. Position the mower on a level, clear spot on your lawn, near enough for your garden hose to reach.



**CAUTION:** Make certain the mower's discharge chute is directed AWAY from your house, garage, parked cars, etc.

2. Thread the hose coupler (packaged with your mower's Operator's Manual) onto the end of your garden hose.
3. Attach the hose coupler to the water port on your deck's surface. See Figure 6-3.

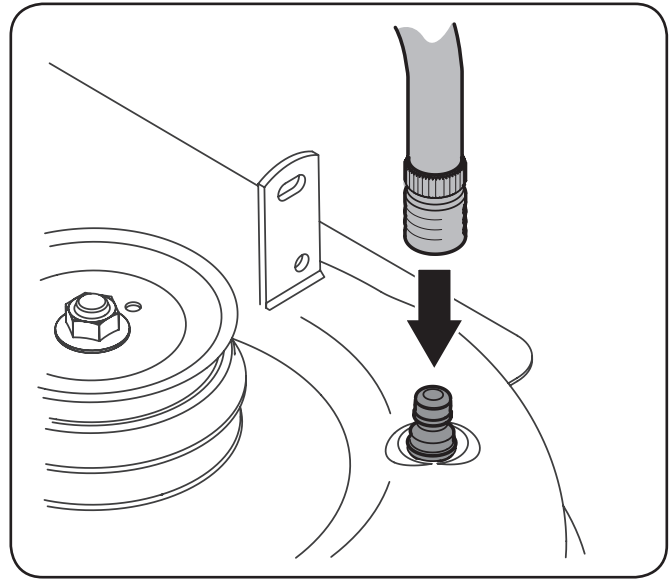

Figure 6-3

4. Turn the water on.
5. Start the engine and place the throttle lever in the FAST (rabbit) position.
6. While in the operator's position behind the mower, move the Blade Control into the ON position.
7. Remain in the operator's position with the cutting deck engaged for a minimum of two minutes, allowing the underside of the cutting deck to thoroughly rinse.
8. Move the Blade Control into the OFF position.
9. Turn the ignition key (for electric start models) to the STOP position to turn the mower's engine off.
10. Turn the water off and detach the hose coupler from the water port on your deck's surface.

After cleaning your deck with the Smart Jet system, start the mower's engine, return to the operator's position and engage the blades. Keep the cutting deck running for a minimum of two minutes, allowing the underside of the cutting deck to thoroughly dry.

## Lubrication



**WARNING!** Before lubricating, repairing, or inspecting, always disengage PTO, set parking brake, stop engine and remove key if so equipped to prevent unintended starting.

### Pivot Points & Linkage

Lubricate all the pivot points on the drive system and lift linkage at least once a season with light oil.

### Rear Wheels

The rear wheels should be removed from the axles once a season. Lubricate the axles and rim hubs well with an all-purpose grease before reinstalling them.

### Front Wheels

Each of the front wheel axles and casters is equipped with a grease fitting. See Figure 6-4. Lubricate with a No. 2 multi-purpose grease applied with a grease gun after every 25 hours of mower operation.

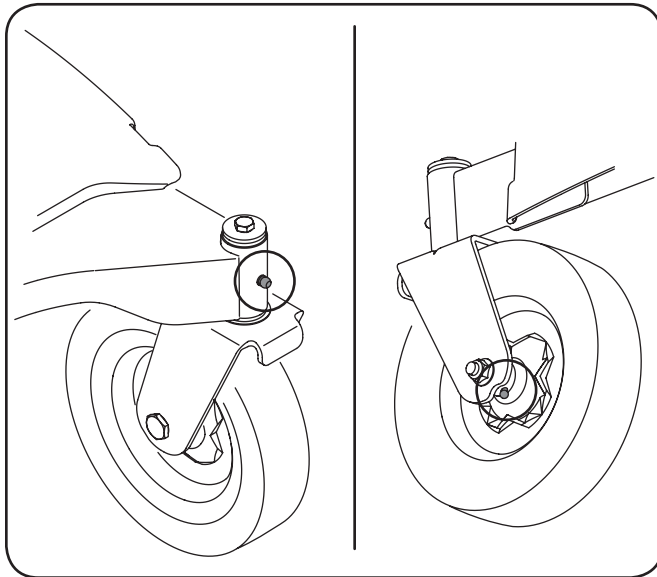

Figure 6-4

## Blade Timing Belt

The cutting deck spindles are driven by timing (cogged) belt, assuring that the deck blades are always perpendicular to each other. At least once a season, or after striking any foreign object, check the timing belt as follows:

1. Remove the belt cover by removing the three screws and washers which secure it to the frame. See Figure 6-5.

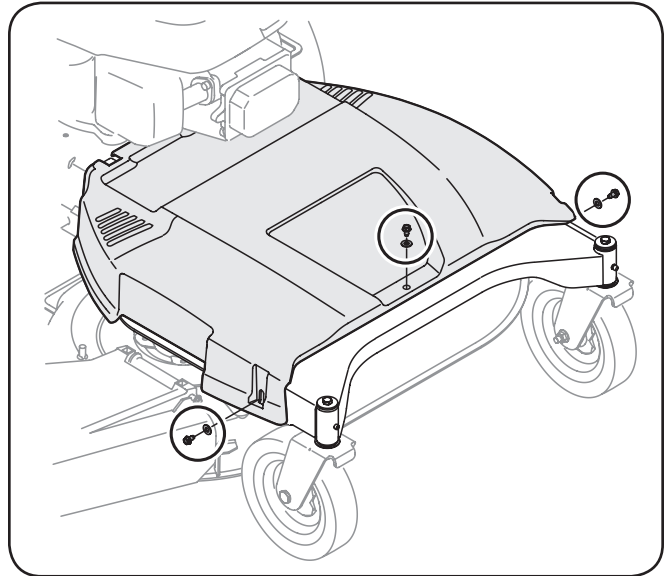
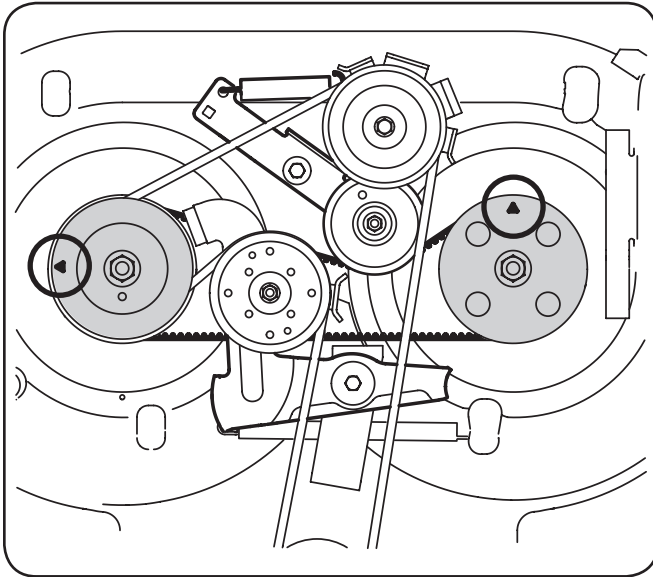

Figure 6-5



**WARNING!** Do not operate mower without the belt cover installed. Failure to follow this instruction could result in personal injury or property damage.

- The top of each spindle pulley is marked with an arrow. See Figure 6-6. The arrows should be perpendicular (at a 90° angle) to each other.



**Figure 6-6**

- If the arrows on the surface of each spindle pulley are not perpendicular (at a 90° angle) to each other, see your Cub Cadet dealer to have the deck's timing belt reset.



**WARNING!** Do not operate the machine without the deck's timing belt properly set. Failure to follow this instruction could result in personal injury or property damage.

## Adjustments



**WARNING!** Shut the engine off and remove the ignition key (if so equipped) before making adjustments.

### Handle Height

The upper handle is secured to two support bars that can be adjusted to raise or lower the handle height. Adjust if necessary as follows:

- Remove the upper star knob and carriage screw on the right side of the handle and the left side of the handle. See Figure 6-7.

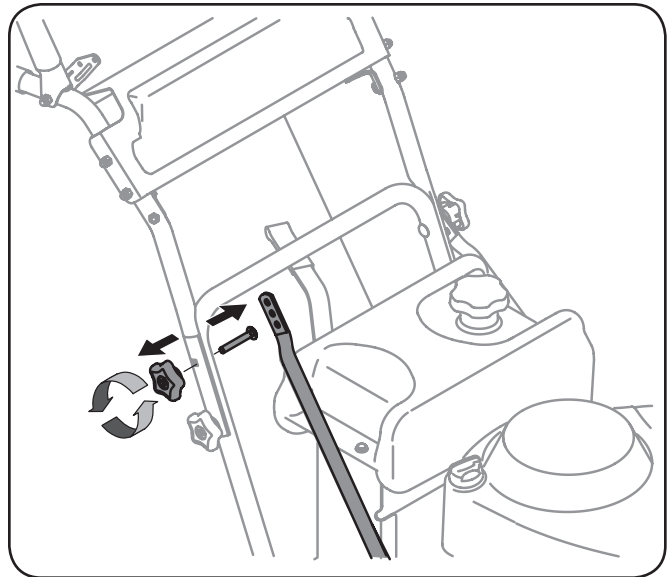

**Figure 6-7**

- Pivot the handle forward or rearward to align one of the three holes on each support bar with the holes on the handle.
- Reinstall the upper star knob and carriage screw on the right side of the handle and the left side of the handle when a comfortable height is achieved.

## Maintenance Schedule

	Each use or every 5-10 Hrs.	Every 10 Hours	Every season or 25 Hours	Every season or 50 Hours	Every season or 100 Hours	Prior to Storing
Clean Mower	✓					✓
Check Engine Oil Level	✓					
Check Air Filter	✓					
Replace Air Filter Element †					✓	
Change Engine Oil ††				✓		
Clean Battery Terminals		✓				✓
Clean Engine Cooling Fins			✓			✓
Clean Finger Guard and around Muffler	✓					
Lube Front Wheels and Casters			✓			✓
Lube Pivot Points		✓				✓
Check Spark Plug Condition & Gap			✓			
Replace Spark Plug					✓	
Replace Fuel Filter					✓	

† Service more frequently when used in dusty areas.

†† Every season or 25 hours if operating under heavy load or high ambient temperature.

## Cutting Deck Removal



**WARNING!** Before performing any maintenance or repairs, disengage blades, stop engine and remove key if so equipped to prevent unintended starting.

To remove the cutting deck, proceed as follows:

1. Remove the belt cover by removing the three screws and washers which secure it to the frame. See Figure 7-1.



**WARNING:** Do not operate mower without the belt cover installed. Failure to follow this instruction could result in personal injury or property damage.

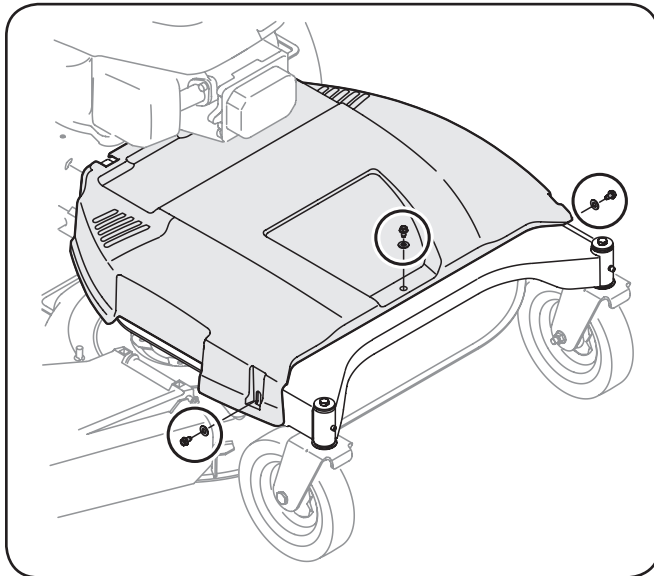

Figure 7-1

2. Place the deck height lever in its highest position.
3. Position wood blocks at various places under the deck's edge. These will temporarily support the deck as you unmount it.
4. Use the deck height lever to lower the deck, so that it rests on the wood blocks.
5. Remove the screw and flange nut which secures the belt keeper rod to the left side of the mower's frame. See Figure 7-2.

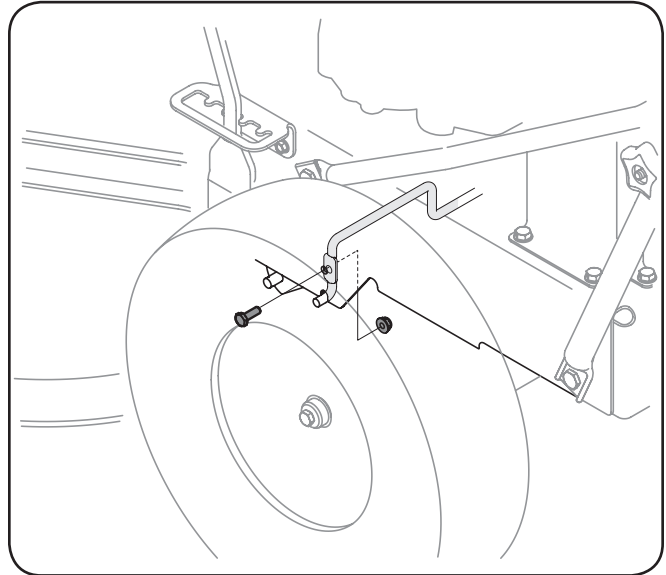

Figure 7-2

6. Remove the belt keeper rod and remove the deck belt from around the mower's engine pulley.
7. Looking at the cutting deck from the left side, locate and carefully remove the hairpin clips that secure the deck supports on the rear left side and front left side of the deck. See Figure 7-3.

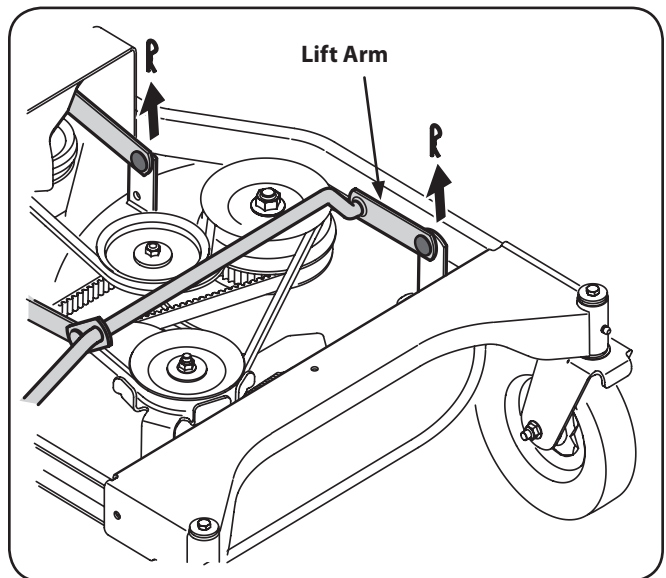
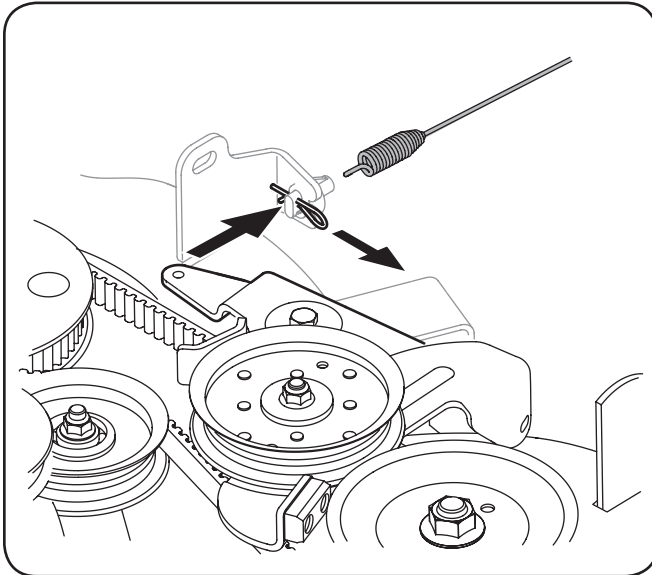

Figure 7-3

8. Repeat the previous step on the mower's right side.
9. Carefully remove the front deck supports from the deck lift arms. See Figure 7-3.

10. Carefully unhook the mower's lift assembly from the rear deck supports.
11. Use the deck height lever to raise the lift assembly to its highest position.
12. Remove the wooden blocks from under the deck and gently slide the cutting deck toward the rear of the machine.
13. Pull the click pin out and unhook the drive spring cable from the idler arm assembly. See Figure 7-4.



**Figure 7-4**

14. Gently slide the cutting deck to the right, out from beneath the mower.

To install the cutting deck, follow the above steps in reverse order to reattach deck and belt cover

## Cutting Blades



**WARNING!** Shut the engine off and remove ignition key (if so equipped) before removing the cutting blade(s) for sharpening or replacement. Protect your hands by using heavy gloves when grasping the blades.



**WARNING!** Periodically inspect the blade and/or spindle for cracks or damage, especially after you've struck a foreign object. Do not operate the machine until damaged components are replaced.

To remove the blades, proceed as follows:

1. Remove the deck from beneath the mower (refer to Cutting Deck Removal earlier in this section), then gently flip the deck over to expose its underside.

2. Place a block of wood between the center deck housing baffle and the cutting blade to act as a stabilizer. See Figure 7-5.

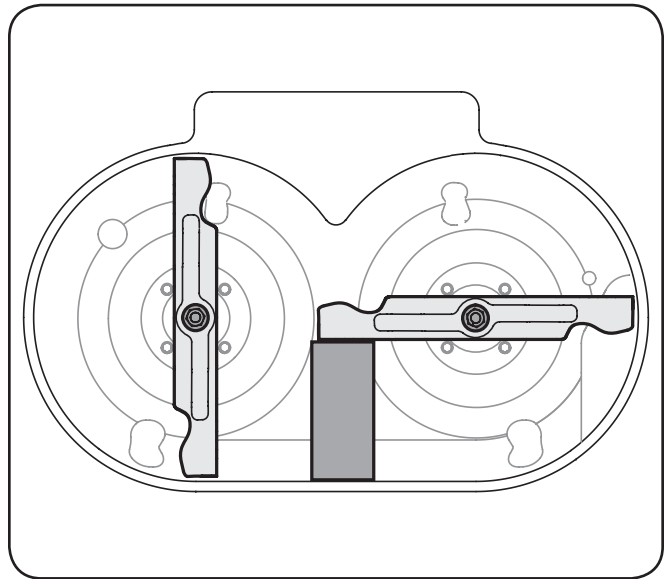

**Figure 7-5**

3. Remove the hex flange nut that secures the blade to the spindle assembly. See Figure 7-5.
4. To properly sharpen the cutting blades, remove equal amounts of metal from both ends of the blades along the cutting edges, parallel to the trailing edge, at a 25° to 30° angle. Always grind each cutting blade edge equally to maintain proper blade balance. See Figure 7-6.

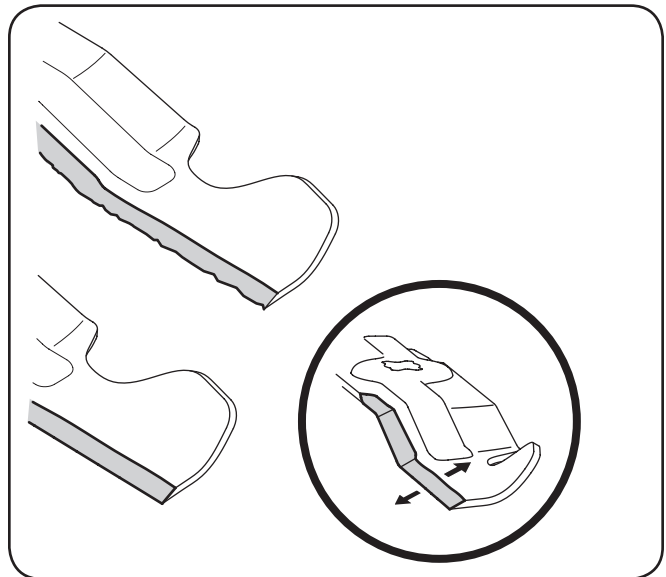

**Figure 7-6**



**CAUTION:** If the cutting edge of the blade has previously been sharpened, or if any metal separation is present, replace the blades with new ones.





**WARNING!** A poorly balanced blade will cause excessive vibration, may damage the mower and/or result in personal injury.

5. Test the blade's balance using a blade balancer. Grind metal from the heavy side until it balances evenly.

**NOTE:** When replacing the blade, be sure to install the blade with the side of the blade marked "Bottom" (or with a part number stamped in it) facing the ground when the mower is in the operating position.



**CAUTION:** Use a torque wrench to tighten the blade spindle hex flange nut to between 70 ft-lbs and 90 ft-lbs.



**CAUTION:** The cutting blades **must** be installed perpendicular to each other. If the blades cannot be installed perpendicular to each other, the blade timing belt must be reset. See your Cub Cadet dealer to have the deck's timing belt reset.

## Trail Shield



**WARNING!** Never operate the mower without the trail shield in place and working. Failure to do so can result in personal injury.

To replace the trail shield, proceed as follows:

1. Remove the screw which secures the trail shield to the right side of the mower. See Figure 7-7.

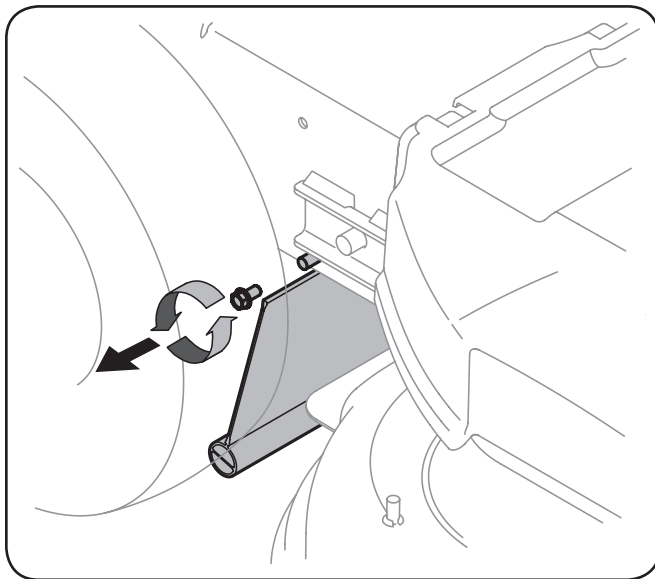

**Figure 7-7**

2. Bow the trail shield inward on each side to release it from the mower frame.
3. Install the replacement trail shield by following the steps above in reverse order.

## Battery (Electric Start Models Only)



**CALIFORNIA PROPOSITION 65 WARNING:** Battery posts, terminals, and related accessories contain lead and lead compounds, chemicals known to the State of California to cause cancer and reproductive harm. Wash hands after handling.



**CAUTION:** If removing the battery, disconnect the NEGATIVE (Black) wire from its terminal first, followed by the POSITIVE (Red) wire. When re-installing the battery, always connect the POSITIVE (Red) wire its terminal first, followed by the NEGATIVE (Black) wire.

## Jump Starting



**WARNING!** Never jump start a damaged or frozen battery. Be certain the vehicles do not touch, and ignitions are off. Do not allow cable clamps to touch.

1. Connect positive (+) cable to positive post (+) of your mower's discharged battery.
2. Connect the other end of the cable to the positive (+) post of the jumper battery.
3. Connect the second cable negative (-) to the other post of the jumper battery.
4. Make the final connection on the engine block of the mower, away from the battery. Attach to an unpainted part to assure a good connection.



**CAUTION:** If the jumper battery is installed on a vehicle (i.e. car, truck), do NOT start the vehicle's engine when jump starting your mower.

5. Start the mower (as instructed in the Operation section of this manual).
6. Remove the jumper cables in reverse order of connection.

## Charging



**WARNING!** Batteries give off an explosive gas while charging. Charge the battery in a well ventilated area and keep away from an open flame or pilot light as on a water heater, space heater, furnace, clothes dryer or other gas appliances.



**CAUTION:** When charging your mower's battery, use only a charger designed for 12V lead-acid batteries. Read your battery charger's Owner's Manual prior to charging your mower's battery. Always follow its instructions and heed its warnings.

If your mower has not been put into use for an extended period of time, set your battery charger to deliver a max of 10 amperes before charging battery.

If your battery charger is automatic, charge the battery until the charger indicates that charging is complete. If the charger is not automatic, charge for no fewer than eight hours.

## Changing the Deck Engagement Belt



**WARNING!** Shut the engine off and remove key if so equipped before removing the cutting blade(s) for sharpening or replacement. Protect your hands by using heavy gloves when grasping blades and pulleys.



**WARNING!** The V-belts found on your mower are specially designed to engage and disengage safely. A substitute (non-OEM) V-belt can be dangerous by not disengaging completely. For a proper working machine, use factory approved belts.

All belts on your mower are subject to wear and should be replaced if any signs of wear are present. To change or replace the deck engagement belt on your mower, proceed as follows:

1. Remove the cutting deck from the mower as instructed earlier in this section.



**WARNING!** Avoid pinching injuries. Never place your fingers on the idler spring or between the belt and a pulley while removing the belt

2. Remove the belt cover as instructed earlier in this section. See Figure 7-1.
3. Remove the belt keeper as instructed earlier in this section. See Figure 7-2.
4. Loosen, but not remove, the nut and bolt which secures each deck idler pulley. See Figure 7-8.

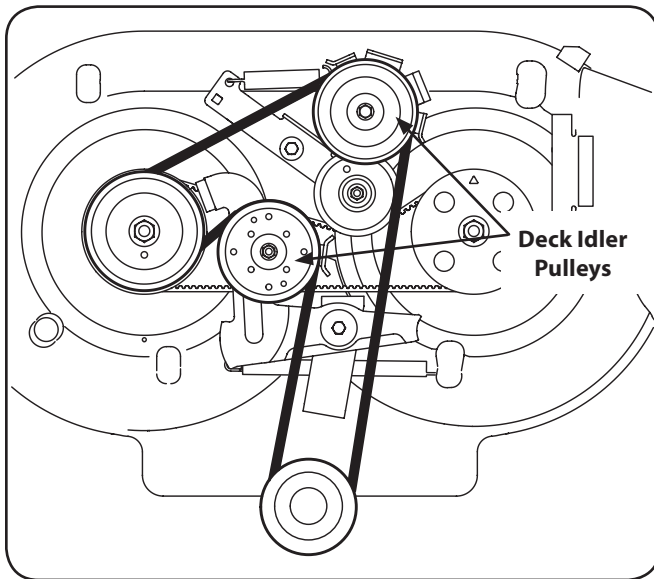

**Figure 7-8**

5. Remove the belt from around all pulleys.
6. Route the new belt as illustrated in Figure 7-8.
7. Retighten the nuts and bolts which secure each idler pulley.
8. Reattach the belt keeper and belt cover.

## Changing the Deck Timing Belt

Several components must be removed and special tools used in order to change the mower deck's timing belt. See your Cub Cadet dealer to have the deck's timing belt replaced.

## Changing the Transmission Drive Belt

Several components must be removed and special tools used in order to change the mower's transmission drive belt. See your Cub Cadet dealer to have the transmission drive belt replaced.

## Fuse (Electric Start Models Only)



**WARNING!** Before servicing, repairing, or inspecting, always disengage blades, stop engine and remove key to prevent unintended starting.



A fuse is installed in your mower's wiring harness to protect the mower's electrical system from damage caused by excessive amperage.

If the electrical system does not function, or your mower's engine will not crank, first check to be certain that the fuse has not blown. It is located near the battery.



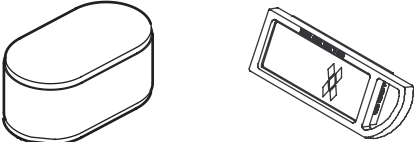

**CAUTION:** Always use a replacement fuse with the same amperage capacity as the blown fuse.

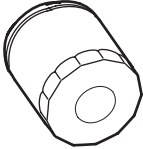
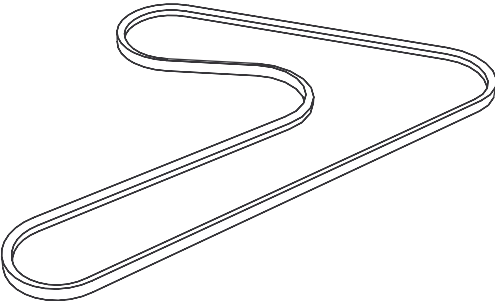
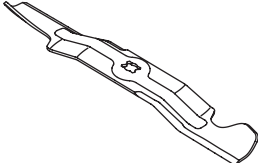
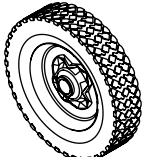
Problem	Cause	Remedy
Engine fails to start	<ol style="list-style-type: none"> <li>1. Choke not activated.</li> <li>2. Fuel tank empty, or stale fuel.</li> <li>3. Blocked fuel line.</li> <li>4. Faulty spark plug.</li> <li>5. Engine flooded.</li> <li>6. Dead battery (electric start models only).</li> <li>7. Blown fuse.</li> </ol>	<ol style="list-style-type: none"> <li>1. Place throttle/choke control in CHOKE position.</li> <li>2. Fill tank with clean, fresh (less than 30 days old) gas.</li> <li>3. Clean fuel line and replace fuel filter.</li> <li>4. Clean, adjust gap or replace plug.</li> <li>5. Crank engine with throttle in FAST position.</li> <li>6. Recharge battery.</li> <li>7. Replace blown fuse.</li> </ol>
Engine runs erratically	<ol style="list-style-type: none"> <li>1. Engine running with CHOKE activated.</li> <li>2. Spark plug wire(s) loose.</li> <li>3. Blocked fuel line or stale fuel.</li> <li>4. Vent in gas cap plugged.</li> <li>5. Water or dirt in fuel system.</li> <li>6. Dirty air cleaner.</li> </ol>	<ol style="list-style-type: none"> <li>1. Move throttle/choke control out of CHOKE position.</li> <li>2. Connect spark plug wire(s).</li> <li>3. Clean fuel line; fill tank with clean, fresh gasoline and replace fuel filter.</li> <li>4. Clear vent or replace cap if damaged.</li> <li>5. Drain fuel tank. Refill with clean, fresh gasoline.</li> <li>6. Replace air cleaner paper element.</li> </ol>
Engine overheats	<ol style="list-style-type: none"> <li>1. Engine oil level low.</li> <li>2. Air flow restricted.</li> </ol>	<ol style="list-style-type: none"> <li>1. Fill crankcase with proper amount and weight of oil.</li> <li>2. Clean grass clippings and debris from around the engine's cooling fins and blower housing.</li> </ol>
Engine hesitates at high RPM	<ol style="list-style-type: none"> <li>1. Spark plug gap too close.</li> </ol>	<ol style="list-style-type: none"> <li>1. Remove spark plug and reset the gap.</li> </ol>
Engine Idles poorly	<ol style="list-style-type: none"> <li>1. Spark plug fouled, faulty or gap too wide.</li> <li>2. Dirty air cleaner.</li> </ol>	<ol style="list-style-type: none"> <li>1. Replace spark plug. Set plug gap.</li> <li>2. Replace air cleaner element and/or clean pre-cleaner.</li> </ol>
Excessive vibration	<ol style="list-style-type: none"> <li>1. Cutting blade loose or unbalanced.</li> <li>2. Damaged or bent cutting blade.</li> </ol>	<ol style="list-style-type: none"> <li>1. Tighten blade and spindle.</li> <li>2. Replace blade.</li> </ol>
Mower will not mulch grass	<ol style="list-style-type: none"> <li>1. Engine speed too low.</li> <li>2. Wet grass.</li> <li>3. Excessively high grass.</li> <li>4. Dull blade.</li> </ol>	<ol style="list-style-type: none"> <li>1. Place throttle in FAST (rabbit) position.</li> <li>2. Do not mulch when grass is wet.</li> <li>3. Mow once at a high cutting height, then mow again at desired height or make a narrower cutting swath.</li> <li>4. Sharpen or replace blade.</li> </ol>
Uneven cut	<ol style="list-style-type: none"> <li>1. Deck not leveled properly.</li> <li>2. Dull blade.</li> <li>3. Uneven tire pressure.</li> </ol>	<ol style="list-style-type: none"> <li>1. Perform side-to-side deck adjustment.</li> <li>2. Sharpen or replace blade.</li> <li>3. Check tire pressure in rear tires.</li> </ol>

Component	Part Number and Description
	951-10292 Spark Plug (MTD) BS-491055S Spark Plug (Briggs) (Champion RC12YC)
	951-12260 Air Filter Cartridge (MTD) 951-12256 Pre-Cleaner (MTD) BS-797007 Air Filter Cartridge (Briggs & Stratton)
	951-12182 Fuel Cap
	951-3013 Fuel Filter (MTD) BS-394358S Fuel Filter (Briggs & Stratton)
	751-11501 Oil Filter (MTD) BS-492932S Oil Filter (Briggs & Stratton)
	954-04139 Belt (Mowing Deck Engagement)
	942-04154A Deck Blade
	634-04345 Wheel (Front) 634-04349 Wheel (Rear)

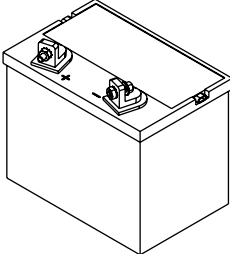
Phone (800) 965-4CUB to order replacement parts or a complete Parts Manual (have your full model number and serial number ready). Parts Manual downloads are also available free of charge at [www.cubcadet.com](http://www.cubcadet.com).

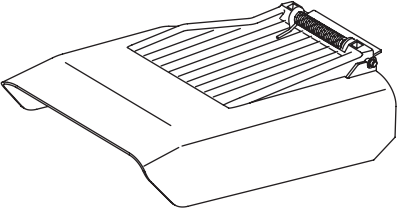
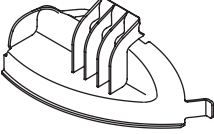
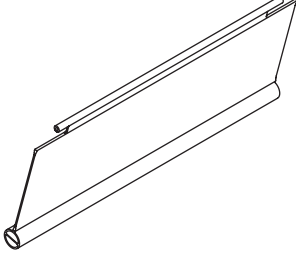
Component	Part Number and Description
	925-1707D† Battery
	946-04604 Throttle/Choke Control (Cable)
	925-2054A† Ignition Key
	931-04244 Discharge Chute Assembly
	631-04252 Mulch Baffle
	731-05766 Trail Shield

† If Equipped

Phone (800) 965-4CUB to order replacement parts or a complete Parts Manual (have your full model number and serial number ready). Parts Manual downloads are also available free of charge at [www.cubcadet.com](http://www.cubcadet.com).

The following attachments and accessories are compatible for the Cub Cadet Wide Cut Mower. See your Cub Cadet dealer or the retailer from which you purchased your mower for information regarding price and availability.

<b>Model Number</b>	<b>Description</b>
19A20001100	Grass Collector, 33" Mower

---



---



---



---



---



---



---



---



---



---



---



---



---



---



---



---



---



---



---



---



---



---



---



---

---

**FEDERAL and/or CALIFORNIA EMISSION CONTROL WARRANTY STATEMENT**  
**YOUR WARRANTY RIGHTS AND OBLIGATIONS**

MTD Consumer Group Inc, the United States Environmental Protection Agency (EPA), and, for those products certified for sale in the state of California, the California Air Resources Board (CARB) are pleased to explain the emission (evaporative and/or exhaust) control system (ECS) warranty on your outdoor 2006 and later small off-road spark-ignited engine and equipment (outdoor equipment engine) In California, new outdoor equipment engines must be designed, built and equipped to meet the State's stringent anti-smog standards (in other states, 1997 and later model year equipment must be designed, built, and equipped to meet the U.S. EPA small off-road, spark ignition engine regulations. MTD Consumer Group Inc must warrant the ECS on your outdoor equipment engine for the period of time listed below provided there has been no abuse, neglect or improper maintenance of outdoor equipment engine.

Your ECS may include parts such as the carburetor, fuel-injection system, the ignition system, catalytic converter, fuel tanks, fuel lines, fuel caps, valves, canisters, filters, vapor hoses, clamps, connectors, and other associated emission-related components.

Where a warrantable condition exists, MTD Consumer Group Inc will repair your outdoor equipment engine at no cost to you including diagnosis, parts and labor.

**MANUFACTURER'S WARRANTY COVERAGE:**

This emission control system is warranted for two years. If any emission-related part on your outdoor equipment engine is defective, the part will be repaired or replaced by MTD CONSUMER GROUP INC.

**OWNER'S WARRANTY RESPONSIBILITIES:**

As the outdoor equipment engine owner, you are responsible for performance of the required maintenance listed in your owner's manual. MTD Consumer Group Inc recommends that you retain all receipts covering maintenance on your outdoor equipment engine, but MTD Consumer Group Inc cannot deny warranty solely for the lack of receipts.

As the outdoor equipment engine owner, you should however be aware that MTD Consumer Group Inc may deny you warranty coverage if your outdoor equipment engine or a part has failed due to abuse, neglect, or improper maintenance or unapproved modifications.

You are responsible for presenting your outdoor equipment engine to MTD Consumer Group Inc's distribution center or service center as soon as the problem exists. The warranty repairs should be completed in a reasonable amount of time, not to exceed 30 days. If you have a question regarding your warranty coverage, you should contact the MTD Consumer Group Inc Service Department at 1-800-800-7310 or via email at <http://support.mtdproducts.com>

**GENERAL EMISSIONS WARRANTY COVERAGE:**

MTD Consumer Group Inc warrants to the ultimate purchaser and each subsequent purchaser that the outdoor equipment engine is: Designed, built and equipped so as to conform with all applicable regulations; and free from defects in materials and workmanship that cause the failure of a warranted part to be identical in all material respects to that part as described in MTD Consumer Group Inc's application for certification.

The warranty period begins on the date the outdoor equipment engine is delivered to an ultimate purchaser or first placed into service. The warranty period is two years.

Subject to certain conditions and exclusions as stated below, the warranty on emission-related parts is as follows:

1. Any warranted part that is not scheduled for replacement as required maintenance in the written instructions supplied, is warranted for the warranty period stated above. If the part fails during the period of warranty coverage, the part will be repaired or replaced by MTD Consumer Group Inc according to subsection (4) below. Any such part repaired or replaced under warranty will be warranted for the remainder of the period.
  2. Any warranted part that is scheduled only for regular inspection in the written instructions supplied is warranted for the warranty period stated above. Any such part repaired or replaced under warranty will be warranted for the remaining warranty period.
  3. Any warranted part that is scheduled for replacement as required maintenance in the written instructions supplied is warranted for the period of time before the first scheduled replacement date for that part. If the part fails before the first scheduled replacement, the part will be repaired or replaced by MTD Consumer Group Inc according to subsection (4) below. Any such part repaired or replaced under warranty will be warranted for the remainder of the period prior to the first scheduled replacement point for the part.
  4. Repair or replacement of any warranted part under the warranty provisions herein must be performed at a warranty station at no charge to the owner.
  5. Notwithstanding the provisions herein, warranty services or repairs will be provided at all of our distribution centers that are franchised to service the subject engines or equipment.
  6. The outdoor equipment engine owner will not be charged for diagnostic labor that is directly associated with diagnosis of a defective, emission-related warranted part, provided that such diagnostic work is performed at a warranty station.
  7. MTD Consumer Group Inc is liable for damages to other engine or equipment components proximately caused by a failure under warranty of any warranted part.
  8. Throughout the off-road engine and equipment warranty period stated above, MTD Consumer Group Inc will maintain a supply of warranted parts sufficient to meet the expected demand for such parts.
  9. Any replacement part may be used in the performance of any warranty maintenance or repairs and must be provided without charge to the owner. Such use will not reduce the warranty obligations of MTD Consumer Group Inc.
-



- 
10. Add-on or modified parts that are not exempted by the Air Resources Board may not be used. The use of any non-exempted add-on or modified parts by the ultimate purchaser will be grounds for disallowing a warranty claims. MTD Consumer Group Inc will not be liable to warrant failures of warranted parts caused by the use of a non-exempted add-on or modified part.

### **WARRANTED PARTS:**

The repair or replacement of any warranted part otherwise eligible for warranty coverage may be excluded from such warranty coverage if MTD Consumer Group Inc demonstrates that the outdoor equipment engine has been abused, neglected, or improperly maintained, and that such abuse, neglect, or improper maintenance was the direct cause of the need for repair or replacement of the part. That notwithstanding, any adjustment of a component that has a factory installed, and properly operating, adjustment limiting device is still eligible for warranty coverage. Further, the coverage under this warranty extends only to parts that were present on the off-road engine and equipment purchased.

The following emission warranty parts are covered (if applicable):

1. Fuel Metering System
  - Cold start enrichment system (soft choke)
  - Carburetor and internal parts (or fuel injection system)
  - Fuel pump
  - Fuel tank
2. Air Induction System
  - Air cleaner
  - Intake manifold
3. Ignition System
  - Spark plug(s)
  - Magneto ignition system
4. Exhaust System
  - Catalytic converter
  - SAI (Reed valve)
5. Miscellaneous Items Used in Above System
  - Vacuum, temperature, position, time sensitive valves and switches
  - Connectors and assemblies
6. Evaporative Control
  - Fuel hose
  - Fuel hose clamps
  - Tethered fuel cap
  - Carbon canister
  - Vapor lines

---

---

---

---

---

---

---

---

---

---

---

---

---

---

---

---

---

---

---

---

---

---

---

---

A series of 22 horizontal lines, evenly spaced, covering the majority of the page's vertical space, intended for writing or drawing.

# CUB CADET LLC

## MANUFACTURER'S LIMITED WARRANTY FOR

### 33-INCH WIDE CUT MOWER

**IMPORTANT:** To obtain warranty coverage owner must present an original proof of purchase and applicable maintenance records to the servicing dealer. Please see the operator's manual for information on required maintenance and service intervals.

The limited warranty set forth below is given by Cub Cadet LLC with respect to new merchandise purchased or leased and used in the United States and/or its territories and possessions, and by MTD Products Limited with respect to new merchandise purchased or leased and used in Canada and/or its territories and possessions (either entity respectively, "Cub Cadet").

This warranty is in addition to any applicable emissions warranty provided with your product.

Cub Cadet warrants this product (excluding its *Normal Wear Parts* and *Battery*, as described below) against defects in material and workmanship for a period of three (3) years or one hundred twenty (120) operation hours, whichever comes first, commencing on the date of original retail purchase or lease and will, at its option, repair or replace, free of charge, any part found to be defective in materials or workmanship.

*Normal Wear Parts* are warranted to be free from defects in material and workmanship for a period of thirty (30) days from the date of original purchase or lease. Normal wear parts include, but are not limited to items such as: belts, blades, blade adapters, grass bags, wheels and tires.

*Batteries* have a one-year prorated limited warranty against defects in material and workmanship, with 100% replacement during the first three months. After three months, the battery replacement credit is based on the months remaining in the twelve (12) month period dating back to the original date of original sale or lease. Any replacement battery will be warranted only for the remainder of the original warranty period.

This limited warranty shall only apply if this product has been operated and maintained in accordance with the Operator's Manual furnished with the product, and has not been subject to misuse, abuse, neglect, accident, improper maintenance, alteration, vandalism, theft, fire, water, or damage because of other peril or natural disaster. Damage resulting from the installation or use of any part, accessory or attachment not approved by Cub Cadet for use with the product(s) covered by this manual will void your warranty as to any resulting damage. In addition, Cub Cadet may deny warranty coverage if the hour meter, or any part thereof, is altered, modified, disconnected or otherwise tampered with.

**HOW TO OBTAIN SERVICE:** Warranty service is available, WITH PROOF OF PURCHASE AND APPLICABLE MAINTENANCE RECORDS, through your local authorized service dealer. To locate the dealer in your area:

#### **In the U.S.A.**

Check your Yellow Pages, or contact Cub Cadet LLC at P.O. Box 361131, Cleveland, Ohio 44136-0019, call 1-877-282-8684 or log on to our website at [www.cubcadet.com](http://www.cubcadet.com).

#### **In Canada**

Contact MTD Products Limited, Kitchener, ON N2G 4J1, call 1-800-668-1238 or log on to our website at [www.mtdcanada.com](http://www.mtdcanada.com).

Without limiting the foregoing, this limited warranty does **not** provide coverage in the following cases:

- a. The engine or component parts thereof. These items may carry a separate manufacturer's warranty. Refer to applicable manufacturer's warranty for terms and conditions.
- b. Routine maintenance items such as lubricants, filters, blade sharpening, tune-ups, brake adjustments, clutch adjustments, deck adjustments, and normal deterioration of the exterior finish due to use or exposure.
- c. Service completed by someone other than an authorized service dealer.
- d. Cub Cadet does not extend any warranty for products sold or exported outside of the United States and/or Canada, and their respective possessions and territories, except those sold through Cub Cadet's authorized channels of export distribution.
- e. Replacement parts and/or accessories that are not genuine Cub Cadet parts.
- f. Transportation charges and service calls.

**There are no implied warranties, including without limitation any implied warranty of merchantability or fitness for a particular purpose. No warranties shall apply after the applicable period of express written warranty above. No other express warranties beyond those mentioned above, given by any person or entity, including a dealer or retailer, with respect to any product, shall bind Cub Cadet. The exclusive remedy is repair or replacement of the product as set forth above.**

**The terms of this warranty provide the sole and exclusive remedy arising from the sale and/or lease of the products covered hereby. Cub Cadet shall not be liable for any incidental or consequential loss or damage including, without limitation, expenses incurred for substitute or replacement lawn care services or for rental expenses to temporarily replace a warranted product.**

Some jurisdictions do not allow the exclusion or limitation of incidental or consequential damages, or limitations on how long an implied warranty lasts, so the above exclusions or limitations may not apply to you.

In no event shall recovery of any kind be greater than the amount of the purchase price of the product sold. **Alteration of safety features of the product shall void this warranty.** You assume the risk and liability for loss, damage, or injury to you and your property and/or to others and their property arising out of the misuse or inability to use the product.

This limited warranty shall not extend to anyone other than the original purchaser or to the person for whom it was purchased as a gift.

**HOW LOCAL LAWS RELATE TO THIS WARRANTY:** This limited warranty gives you specific legal rights, and you may also have other rights that vary in different jurisdictions.

**Cub Cadet LLC, P.O. BOX 361131 CLEVELAND, OHIO 44136-0019, Phone: 1-877-282-8684**  
**MTD Products Limited, Kitchener, ON N2G 4J1, Phone: 1-800-668-1238**