

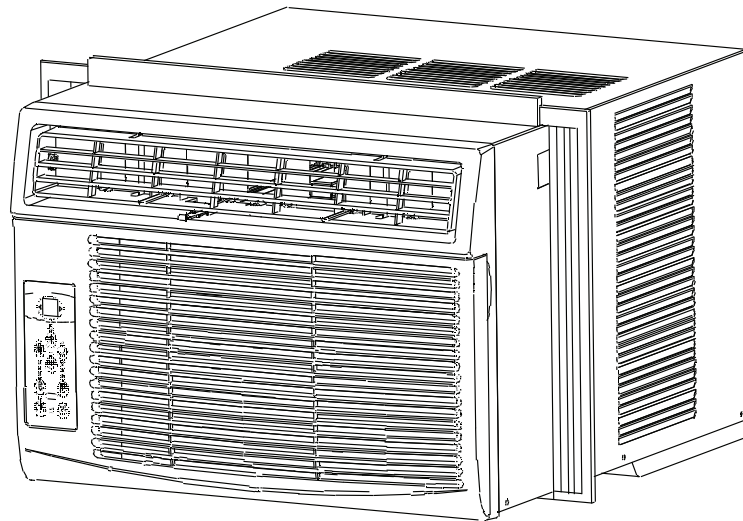

USER'S MANUAL

WINDOW AIR CONDITIONER

WA-60FMS1: 6,000 BTU
WA-80FMS1: 8,000 BTU
WA-10FMS1: 10,000 BTU
WA-12FMS1: 12,000 BTU



MULTI-STEP SPEED ELECTRONIC CONTROL

TABLE OF CONTENTS

Important Safety Instructions	1-3	Air Conditioner Features.....	10-11
Installation Instructions	4-8	Care and Cleaning	11-12
Normal Sounds	9	Remote Control	12-15
		Troubleshooting Tip.....	16





Before using your air conditioner, please read this manual carefully and keep it for future reference.

IMPORTANT SAFETY INSTRUCTIONS

READ THIS MANUAL

Inside you will find many helpful hints on how to use and maintain your air conditioner properly. Just a little preventive care on your part can save you a great deal of time and money over the life of your air conditioner. You'll find many answers to common problems in the chart of troubleshooting tips. If you review our chart of Troubleshooting Tips first, you may not need to call for service at all.

To prevent injury to the user or other people and property damage, the following instructions must be followed. Incorrect operation due to ignoring of instructions may cause harm or damage. The seriousness is classified by the following indications.

 WARNING	This symbol indicates the possibility of death or serious injury.		
 CAUTION	This symbol indicates the possibility of injury or damage to property.		
	Never do this.		Always do this.

WARNING

<p> Plug in power plug properly.</p> <ul style="list-style-type: none"> ● Otherwise, it may cause electric shock or fire due to excess heat generation. 	<p> Do not operate or stop the unit by inserting or removing the power plug.</p> <ul style="list-style-type: none"> ● It may cause electric shock or fire due to heat generation. 	<p> Do not damage or use an unspecified power cord.</p> <ul style="list-style-type: none"> ● It may cause electric shock or fire. ● If the power cord is damaged, it must be replaced by the manufacturer or an authorised service centre or a similarly qualified person in order to avoid a hazard.
<p> Always install circuit breaker and a dedicated power circuit.</p> <ul style="list-style-type: none"> ● Incorrect installation may cause fire and electric shock. 	<p> Do not operate with wet hands or in damp environment.</p> <ul style="list-style-type: none"> ● It may cause electric shock. 	<p> Do not direct airflow directly at room occupants</p> <ul style="list-style-type: none"> ● This is not beneficial to one's health.
<p> Always ensure proper grounding.</p> <ul style="list-style-type: none"> ● Incorrect grounding may cause electric shock. 	<p> Do not allow water to run into electric parts.</p> <ul style="list-style-type: none"> ● It may cause failure of machine or electric shock. 	<p> Do not modify power cord length or share the outlet with other appliances.</p> <ul style="list-style-type: none"> ● It may cause electric shock or fire due to heat generation.
<p> Do not open the unit during operation.</p> <ul style="list-style-type: none"> ● It may cause electric shock. 	<p> Do not use the socket if it is loose or damaged.</p> <ul style="list-style-type: none"> ● It may cause fire and electric 	<p> Unplug the unit immediately if strange sound, smell or smoke is emitting from unit.</p> <ul style="list-style-type: none"> ● It may cause fire and electric shock.
<p> Keep firearms away.</p> <ul style="list-style-type: none"> ● It may cause fire. 	<p> Keep power cord away from heat sources.</p> <ul style="list-style-type: none"> ● It may cause fire and electric shock. 	<p> Do not use the power cord near flammable gas or combustibles, such as gasoline, benzene, thinner, etc.</p> <ul style="list-style-type: none"> ● It may cause an explosion or fire.
<p> If there was a gas leak from another appliance, ventilate the room thoroughly before operating the unit.</p> <ul style="list-style-type: none"> ● It may cause explosion, fire and, burns. 	<p> Do not disassemble or modify the unit.</p> <ul style="list-style-type: none"> ● It may cause failure and electric shock. 	

IMPORTANT SAFETY INSTRUCTIONS

CAUTION

⊖ When removing and cleaning the filter, be cautious of sharp edges and corners.

- It may cause an injury.

⊖ Do not use strong detergent such as wax or thinner to clean the unit.

- Appearance may be deteriorated due to change of product color or scratching of its surface.

⊖ Stop operation and close the window in storm or hurricane.

- Opened window may lead to interior damage of furniture, floor and others.

⊖ Clean filters once every two weeks. Be sure filter is installed properly.

- Operation without filters may cause failure.

⊖ Do not block air inlets and outlets.

- It may cause failure of appliance or accident.

⊖ Use caution when unpacking and installing. Sharp edges could cause injury.

⊖ Do not situate a pet or house plant where it will be exposed to direct air flow.

- This could injure the pet or plant.

⊖ Do not clean the air conditioner with water or spray bottle.

- Water may enter the unit and degrade the insulation. It may cause an electric shock.

⊖ Before cleaning and maintenance, be sure power is turned off and plug disconnected.

- Do not clean unit while operating. May cause fire, electric shock or injury.

⊖ Remove plug from outlet by grasping the plug, never pull on the cord.

- It may cause electric shock and damage.

⊖ Do not place heavy object on the power cord and ensure that the cord is not compressed.

- There is danger of fire or electric shock.

⊖ If water enters the unit, turn the unit off and unplug from power source. Contact a qualified service technician.

⊖ Keep room well ventilated if used within the same room with a stove, etc.

- An oxygen shortage may occur.

⊖ Not intended for special purposes.

- Do not use this air conditioner to preserve precision devices, food, pets, plants, and art objects. It may cause deterioration of quality, etc.

⊖ Inspect brackets frequently to ensure no damages occurred due to prolonged exposure to elements.

- If bracket is damaged, there is concern of the unit falling off.

⊖ Unplug from power source if unit is not to be used for a long time.

- It may cause failure of product or fire.

⊖ Do not consume the water drained from air conditioner.

- It contains contaminants and could make you sick.

CAUTION

- This appliance is not intended for use by persons (including children) with reduced physical, sensory or mental capabilities or lack of experience and knowledge, unless they have been given supervision or instruction concerning use of the appliance by a person responsible for their safety.
- Children should be supervised to ensure that they do not play with the appliance.
- If the supply cord is damaged, it must be replaced by the manufacturer, its service agent or similarly qualified persons in order to avoid a hazard.

- The appliance shall be installed in accordance with national wiring regulations.
- Do not operate your air conditioner in a wet room such as a bathroom or laundry room.
- The appliance with electric heater shall have at least 1 meter space to combustible materials.
- Contact an authorized service technician for repair or maintenance of this unit.
- Contact the manufacturer or an installer if you have questions regarding installation of this unit.

IMPORTANT SAFETY INSTRUCTIONS

NOTE:

The power supply cord with this air conditioner contains a current detection device designed to reduce the risk of fire. Please refer to the section Operation of Current Device for details. In the event that the power supply cord is damaged, it cannot be repaired-it must be replaced with a cord from the manufacturer.

WARNING

Avoid fire hazard or electric shock. Do not use an extension cord or an adaptor plug. Do not remove any prong from the power cord.

Grounding type wall receptacle

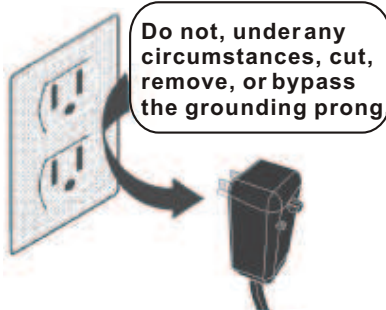

Power supply cord with 3-prong grounding plug and current detection device

WARNING

For Your Safety

Do not store or use gasoline or other flammable vapors and liquids in the vicinity of this or any other appliance.

WARNING

Prevent Accidents

To reduce the risk of fire, electrical shock, or injury to persons when using your air conditioner, follow basic precautions, including the following:

- Be sure the electrical service is adequate for the model you have chosen. This information can be found on the serial plate, which is located on the side of the cabinet and behind the grille.
- If the air conditioner is to be installed in a window, you will probably want to clean both sides of the glass first. If the window is a triple-track type with a screen panel included, remove the screen completely before installation.
- Be sure the air conditioner has been securely and correctly installed according to the installation instructions in this manual. Save this manual for possible future use in removing or installing this unit.
- When handling the air conditioner, be careful to avoid cuts from sharp metal fins (front and rear coils).

WARNING

Electrical Information

The complete electrical rating of your new room air conditioner is stated on the serial plate. Refer to the rating when checking the electrical requirements.

- Be sure the air conditioner is properly grounded. To minimize shock and fire hazards, proper grounding is important. The power cord is equipped with a three-prong grounding plug for protection against shock hazards.
- Your air conditioner must be used in a properly grounded wall receptacle. If the wall receptacle you intend to use is not adequately grounded or protected by a time delay fuse or circuit breaker, have a qualified electrician install the proper receptacle. Ensure the receptacle is accessible after the unit installation.
- Do not run air conditioner without side protective cover in place. This could result in mechanical damage within the air conditioner.
- **Do not use an extension cord or an adapter plug.**

Operation of Current Device

(Applicable to the unit adopts current detection device only)

The power supply cord contains a current device that senses damage to the power cord. To test your power supply cord do the following:

1. Plug in the Air Conditioner.
2. The power supply cord will have TWO buttons on the plug head. Press the TEST button, you will notice a click as the RESET button pops out.
3. Press the RESET button, again you will notice a click as the button engages.
4. The power supply cord is now supplying electricity to the unit. (On some products this it also indicated by a light on the plug head.)

NOTE:

- Do not use this device to turn the unit on or off.
- Always make sure the RESET button is pushed in for correct operation.
- The power supply must be replaced if it fails to reset when TEST button is pushed or when it cannot be reset. A new one can be obtained from the manufacturer.
- If power supply cord is damaged, it cannot be repaired. It MUST be replaced by one obtained from the manufacturer.

NOTE: This air conditioner is designed to be operated under the following conditions:

Cooling	Outdoor temp:	64-109°F/18-43°C
	Indoor temp:	62-90°F/17-32°C

Note: Performance may be reduced outside of these operating temperatures.

INSTALLATION INSTRUCTIONS

STOP BEFORE YOU BEGIN

Read these instructions completely and carefully.

IMPORTANT- Save these instructions for local inspector's use.

IMPORTANT- Observe all governing codes and ordinances.

Note to Installer- Be sure to leave these instructions with the Consumer.

Note to Consumer- Keep these instructions for future reference.

Skill level- Installation of this appliance requires basic mechanical skills.

Completion time- Approximately 1 hour. We recommend that two people install this product.

Proper installation is the responsibility of the installer.

Product failure due to improper installation is not covered under the Warranty.

You **MUST** use all supplied parts and use proper installation procedures as described in these instructions when installing this air conditioner.

! WINDOW REQUIREMENTS

Your air conditioner is designed to install in standard double hung windows with opening widths of 23 to 36 inches (584mm to 914mm).

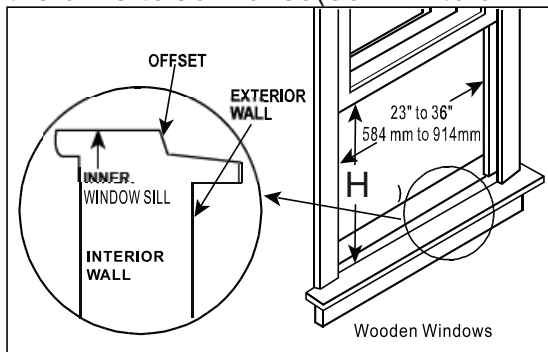

Model	WA-60FMS1 WA-80FMS1	WA-10FMS1 WA-12FMS1
Min vertical opening	14" (356mm)	15.5" (394mm)

Table 1

! CAUTION

Do not, under any circumstances, cut or remove the third (ground) prong from the power cord.

Do not change the plug on the power cord of the air conditioner.

Aluminum house wiring may present special problems- consult a qualified electrician.

When handling unit, be careful to avoid cuts from sharp metal edges and aluminum fins located on the front and rear coils.

TOOLS YOU WILL NEED

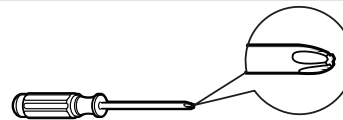

Phillips
Screwdriver



Leveler

TOOLS YOU MAY USE



Slotted Screwdriver



Pencil

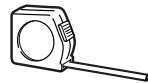

Ruler or tape measure



Scissors or knife

! NOTE:

Save Carton and these Installation Instructions for future reference. The carton is the best way to store unit during winter or when not in use.

INSTALLATION INSTRUCTIONS

1 PREPARE THE WINDOW

Side and rear of unit needs to be clear of obstacles to allow airflow through condenser. The rear of the unit must be outdoors, not inside a building or garage.

Mounting Hardware

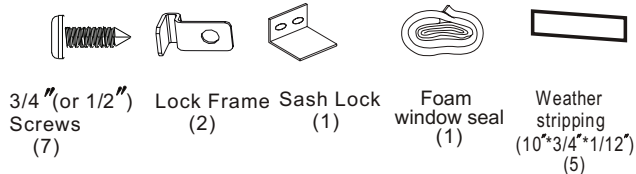

2 PREPARE AIR CONDITIONER

A: Remove the air conditioner from packaging and place on a flat surface.

B: Remove top rail and R1 hardware from packaging material as shown in Fig. A.

NOTE: Top rail hardware and installation is only applicable to models WA-60FMS1 and WA-80FMS1.

Top Rail Hardware

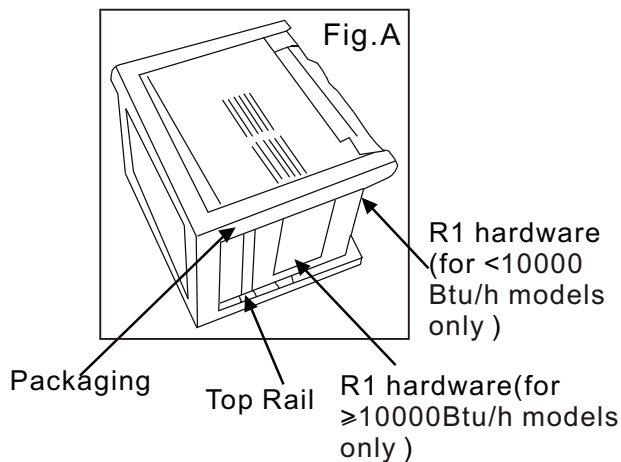
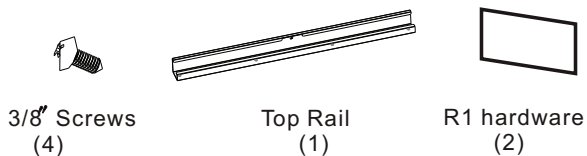

C: Align screw openings on the top rail to those on the top of the unit. Fig. B

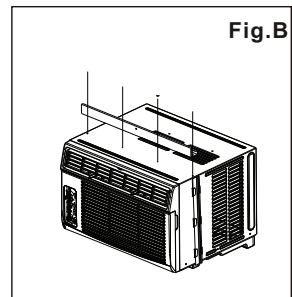

D: Secure top rail to the unit with the 3/8" Screws. Fig. C.

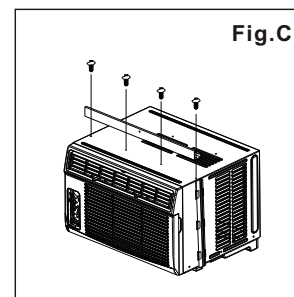

NOTE: For safety reasons, all four (4) screws MUST be securely fastened.

NOTE: The top rail must be assembled before installing the unit.

3 INSTALL THE ACCORDION PANELS

NOTE: Top rail and side panels at each side are offset to provide the proper pitch to the rear of (5/16"). This is necessary for proper condensed water utilization and drainage. If the side panels are not used, this pitch still needs to be maintained.

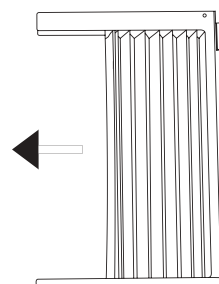

A. Place unit on floor or sturdy table. Hold the accordion side panel in one hand and gently pull back the center to free the open end. See Fig. 1

INSTALLATION INSTRUCTIONS

- B. Slide the free end "I" section of the panel directly into the cabinet as shown in Fig. 2. Slide the panel down. Be sure to leave enough space to slip the top and bottom of the frame into the rails on the cabinet.

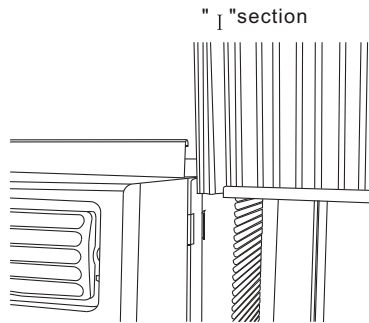

Fig.2

- C. Once installed, check to make sure panel sits securely inside the frame channel by making slight adjustments. Slide the top and bottom ends of the frame into the top and bottom rails of the cabinet. Fig. 3.

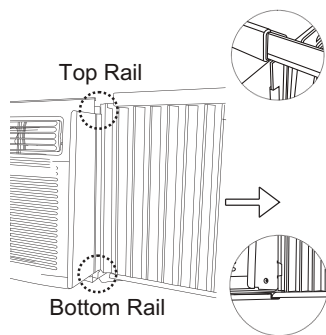

Fig.3

- D. Slide the panel all the way in and repeat on the other side.

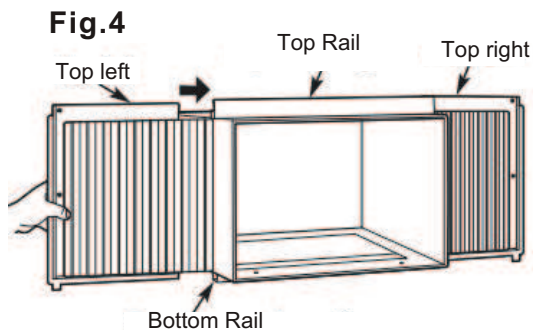

Fig.4

NOTE: If storm window blocks AC, see Fig. 11.

4 SECURE THE ACCORDION PANELS

- A. With a firm grip on the air conditioner, carefully place the unit into the window opening. The bottom of the air conditioner frame should sit against the window sill (Fig.5). Carefully bring the window down behind the top rail.

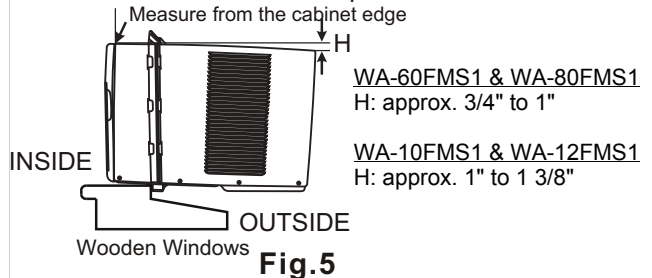

Fig.5

NOTE: Check that air conditioner is tilted back within the indicated "H" measurement (Fig.5), approximately 3° to 4° downwards to the outside. With proper installation, condensate will drain from the drain hole during normal use.

- B. Extend the side panels out against the window frame (Fig.6).

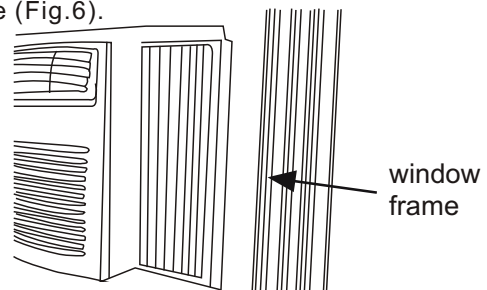

Fig.6

5 INSTALL SUPPORT BRACKET

- A. Place the frame lock between the frame extensions and the window sill as shown in Fig 7. Drive 3/4" (19mm) or 1/2" (12.7mm) locking screws through the frame lock and into the sill.

NOTE: To prevent window sill from splitting, drill 1/8" (3mm) pilot holes before driving screws.

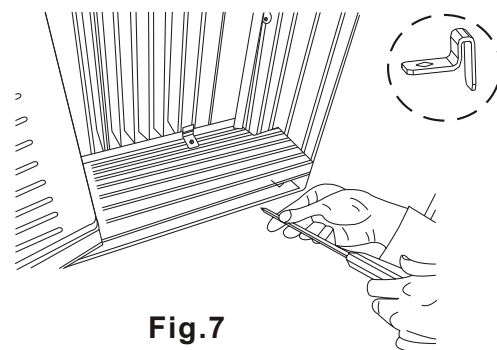

Fig.7

INSTALLATION INSTRUCTIONS

B. Drive 3/4" (19mm) or 1/2" (12.7mm) locking screws through frame holes into window sash (Fig.8).

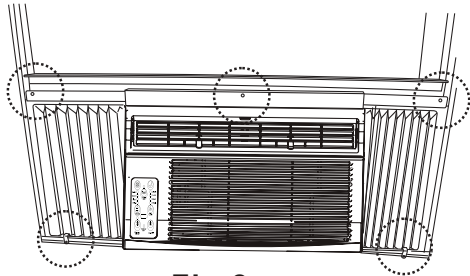

Fig.8

C. To secure lower sash in place, attach right angle sash lock with 3/4" (19mm) or 1/2" (12.7mm) screw as shown in Fig. 9.



Fig.9

D. Cut foam window seal and insert it into the space between the upper and lower sashes. Fig. 10.

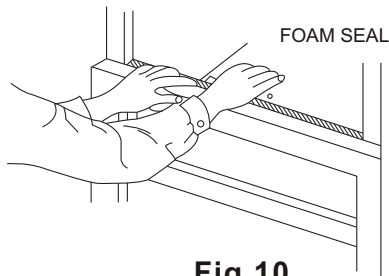

Fig.10

6 INSTALL R1 HARDWARE

In order to minimize air leaks and ensure optimal insulation, it is necessary to install the included R1 hardware to the side curtain.

Step 1. After the unit is installed to the window, measure the inner width of the side curtain as shown in Fig.11.

Step 2. Mark the width measured in Step 1, less 1/8" onto the R1 insulation panel. Draw a line at this measurement and cut the panel along this line. Fig. 12.

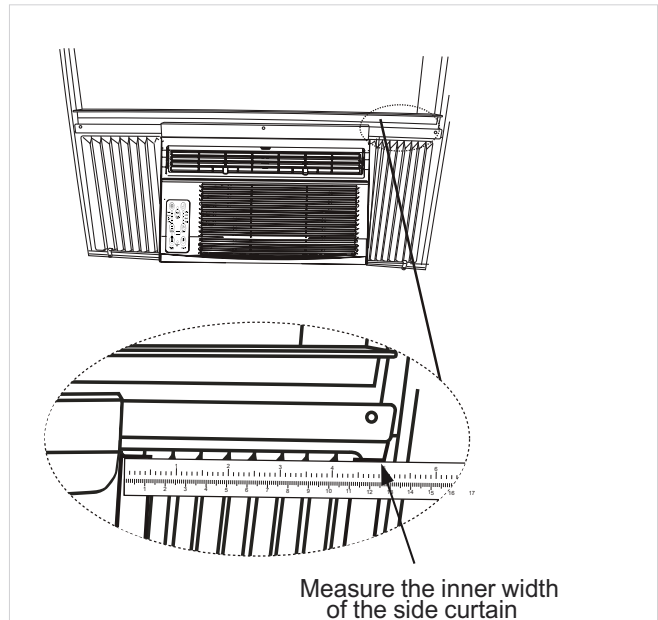

Fig.11

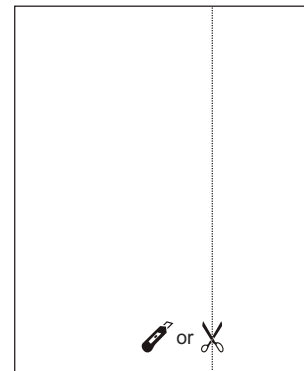

Fig.12

Step 3. Slide the R1 insulation panel into the side curtain. The patterned side faces indoors. Fig.13.

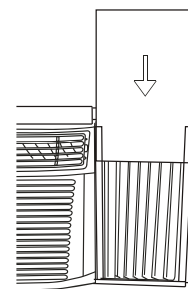

Fig.13

Step 4. Repeat on the other side.

INSTALLATION INSTRUCTIONS

7 INSTALL WEATHER STRIPPING

Installing the weather strip will minimize air leaks between the air conditioner and window opening. Trim the weather strip to the proper length, peel off the protective backing and insert into any gaps and openings. Fig 14.

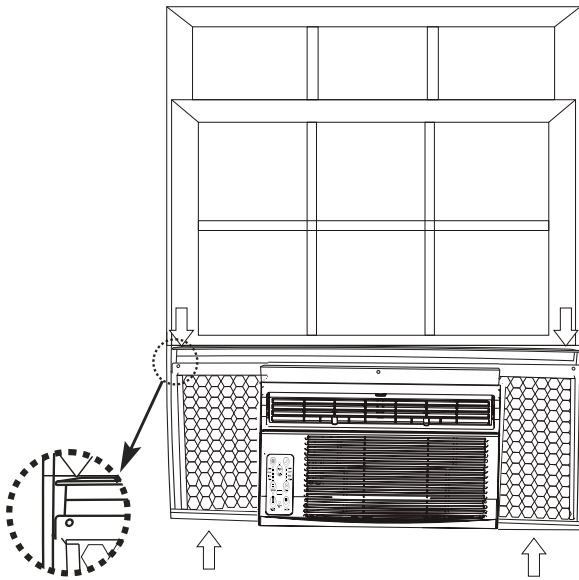

Fig.14

If AC is Blocked by Storm Window

Add wood as shown in Fig.15, or remove storm window before air conditioner is installed.

If Storm Window Frame must remain, be sure the drain holes or slots are not caulked or painted shut. Accumulated rain water or condensation must be allowed to drain out.

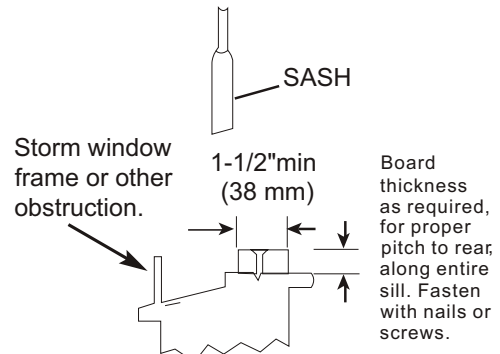
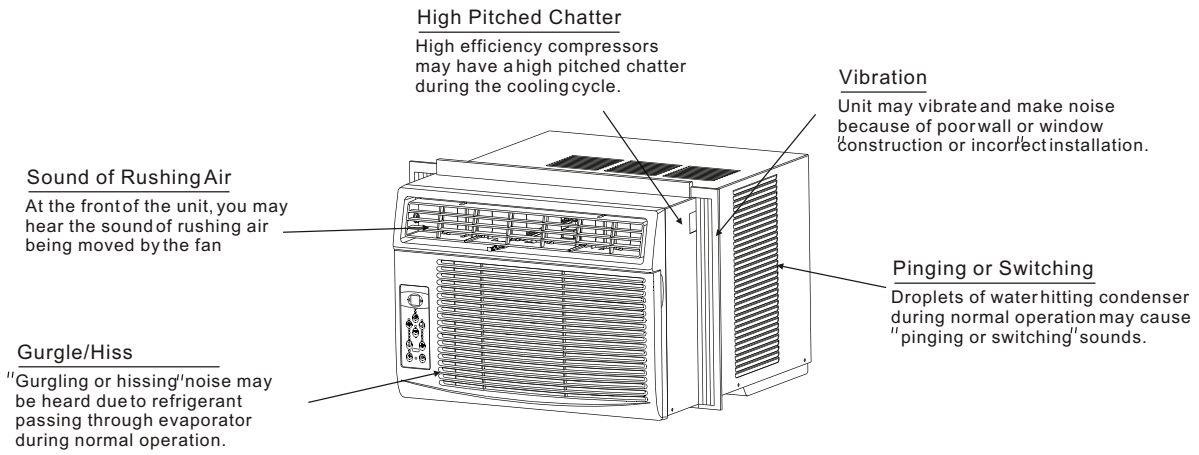

Fig.15

Removing AC From Window

- Turn AC off and disconnect power cord.
- Remove sash seal from between windows, and unscrew safety sash lock.
- Remove screws installed through frame and frame-lock.
- Remove the R1 Panel and close (slide) side panels into frame.
- Keeping a firm grip on air conditioner, raise sash and carefully remove.
- Be carefully not to spill any remaining water while lifting unit from window. Store parts WITH air conditioner.

NORMAL SOUNDS



NOTE:

All the illustrations in this manual are for explanation purpose only. Your air conditioner may be slightly different. The actual shape shall prevail.

AIR CONDITIONER FEATURES

ELECTRONIC CONTROL OPERATING INSTRUCTIONS

Before you begin, thoroughly familiarize yourself with the control panel as shown below and all its functions, then follow the symbol for the functions you desire. **The unit can be controlled by the unit control alone or with the remote.**

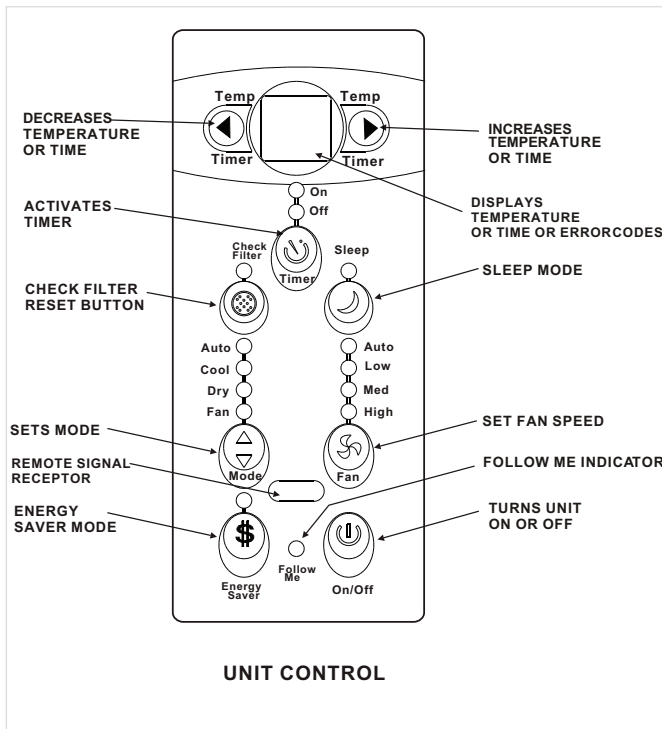

TO TURN UNIT ON OR OFF:

Press **ON/OFF** button to turn unit on or off.

NOTE: The unit will automatically initiate energy Saver function under Cool, Dry and Auto modes.

TO CHANGE TEMPERATURE SETTING:

Press **LEFT/RIGHT** button to change temperature setting.

NOTE: Press or hold either Right (▶) or Left (◀) button until the desired temperature is seen on the display. This temperature will be automatically maintained (between 62°F/17°C to 86°F/30°C). If you want the display to show the actual room temperature, refer to "Operate on Fan Only" section.

CHECK FILTER FEATURE:

Press **Check filter** button to initiate this feature. This feature is a reminder to clean the Air Filter for more efficient operation. The LED light will illuminate after 250 hours of operation. Once filter has been cleaned, press this button to reset.

AIR CONDITIONER FEATURES

SLEEP FEATURE:

Press  Sleep button to initiate the sleep mode. The unit will operate at the set temperature for 30 minutes and proceed to increase temperature by 2°F. After another 30 minutes, unit will again increase temperature by 2°F. This new temperature will be maintained for 6 hours then return to the originally set temperature. This ends the Sleep mode and unit will continue to operate as originally programmed. Sleep mode can be cancelled at anytime during operation by pressing the Sleep button again.

ENERGY SAVER FEATURE:

Press  Energy saver button to initiate this function. This function is available for COOL, DRY and AUTO modes. When the set temperature has been reached and compressor shuts off, fan will continue to run for another 3 minutes, then cycles on for 2 minutes at 10-minute intervals until the room temperature is above the set temperature, at which point the compressor turns back on and cooling resumes.

FOLLOW ME FEATURE:

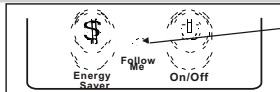

Light flashing

This feature can be ONLY be activated from the remote control. The remote control's thermostat serves as the temperature control point.

To activate the Follow Me feature, point the remote control towards the unit and press the Follow Me button. The remote will display ambient temperature of its current location. The remote control will send signal to the air conditioner every 3 minutes until Follow Me feature is turned off. If the unit does not receive the Follow Me signal for 7 minutes, unit will beep and end the Follow Me feature.

TIMER: AUTO START/STOP FEATURE:

- Press the  TIMER button to program Auto-On or Auto-Off. The corresponding indicator light will illuminate.
- Use the Left/Right arrow buttons to program. each press is in increment of 0.5 hours up to 10 hours, then in increments of 1 hour up to 24 hours. the control will count down the remaining time.
- Unit will register timer setting after 5 seconds. If unit is on, display will revert back to previous temperature setting or room temperature. If unit is off, there will be no display.
- Turning the unit on or off or adjusting the timer to 0.0 will cancel the timer program.

TO SELECT THE OPERATING MODE:

To choose operating mode, press  Mode button. With each press of the button, the mode will cycle through the following sequence: Auto, Cool, Dry and Fan. The indicator light next to each corresponding model will illuminate.

Note: unit will automatically initiate the Energy Saver function under Cool, Dry and Auto modes.

AUTO mode:

- When the air conditioner is set in AUTO mode, unit will automatically select cooling or fan operation, based on set and ambient temperature.
- Unit engages COOL mode when ambient temperature is 4°F above set temperature. When ambient temperature falls 2°F below set temperature, unit will switch to Fan.
- Fan speed cannot be adjusted in AUTO mode.

COOL mode:

Unit begins cooling when ambient temperature is 2°F above set temperature. When set temperature has been reached, cooling stops and unit switches to Fan.

DRY mode:

In this mode, unit will generally operate in the form of a dehumidifier. Since the conditioned space is closed or seals area, some degree of cooling will occur.

FAN mode:

- Use this function when cooling is not desired, such as for air circulation or to exhaust stale air. Best to open windows when operating in Fan mode but remember to close windows in Cool mode for maximum cooling efficiency.
- Fan speed can be adjusted.
- Display will show ambient room temperature.
- Temperature cannot be set or adjusted.

TO ADJUST FAN SPEEDS:

Press  to select the Fan Speed in four steps-Auto, Low, Med or High. Each time the button is pressed, the fan speed mode is shifted. On Dry mode, the fan speed is controlled at Low automatically.

AUTO RESTART FEATURE:

If the unit breaks off unexpectedly due to the power cut, it will restart at the previous function/setting automatically when the power resumes.

AIR CONDITIONER FEATURES

DISPLAYS:

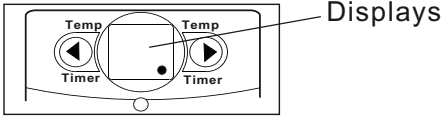

DISPLAYS:

- COOL mode: shows the set temperature in °C or °F and Auto-timer settings.
- FAN mode: shows ambient room temperature.

ERROR CODES

- "AS" = room temperature sensor error.
NOTE: In Fan mode, display will be "LO" or "HI".
 - ". ." = Evaporator temperature sensor error.
 - "HS" = electric sensor error.
- Unplug unit, wait 3 minutes and plug it back in. If error persists, call for service.

ADDITIONAL THINGS YOU SHOULD KNOW

Now that you have mastered the operating procedure, here are more features in your control that you should become familiar with.

- The Cool circuit has an automatic 3 minute time delay when unit is turned off and on quickly. This protects the compressor from overheating and possible circuit breaker tripping. The fan will continue to run during this time.
- The LCD is capable of displaying temperature in Fahrenheit or Celsius. To convert from one to the other, press and hold the Left and Right buttons simultaneously for 3 seconds.

Air Directional Louvers

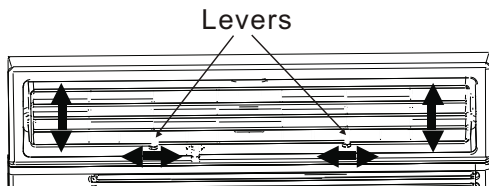

Air Direction

Directional louvers can be adjusted Left or Right and Up or Down (not all models). Pivot the louvers until desired direction is obtained.

Fresh Air Vent Control

(WA-10FMS1 and WA-12FMS1 only):

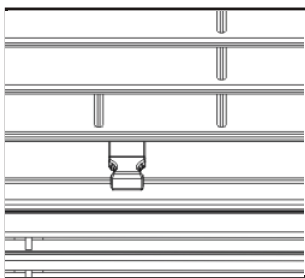

Fig. A (VENT CLOSED)
Circulates indoor air

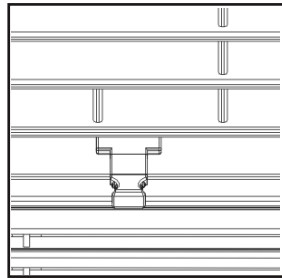

Fig. B (VENT OPEN)
Draws fresh air into the room

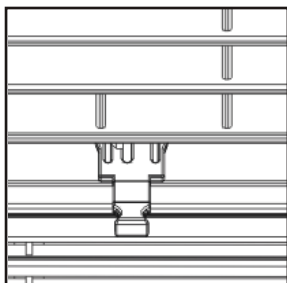

Fig. C (VENT & EXHAUST OPEN)
Indoor and outdoor air exchange

CARE AND CLEANING

⚠ CAUTION

Clean your air conditioner occasionally to keep it looking new. **Be sure to unplug the unit before cleaning to prevent shock or fire hazards.**

Air Filter Cleaning

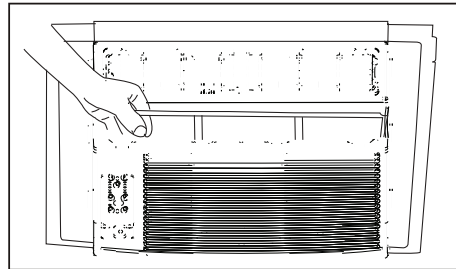

The air filter should be checked at least once a month to see if cleaning is necessary. Trapped particles filter can build up and cause an accumulation of frost on the cooling coils:

- Push the vent handle to the Closed position (where applicable). Open the front panel.
- Grasp the filter by the center and pull up and out.
- Wash the filter using liquid dishwashing detergent and warm water. Rinse filter thoroughly.
- Gently shake excess water from the filter. Be sure filter is thoroughly dry before replacing.
- Instead of washing you may also vacuum the filter.

NOTE: never use hot water over 40°C/104°F to clean the air filter. Never attempt to operate the unit without filter.

CARE AND CLEANING

Cabinet Cleaning

- Be sure to unplug the unit to prevent shock or firehazard. The cabinet and front may be dusted with an oil-free cloth or wipe with a cloth dampened in a warm water and mild detergent solution. Wipe clean and dry thoroughly. Never use harsh cleaners, wax or polish on the cabinet front.
- Be sure to wring excess water from the cloth before wiping the controls. Water in or around the controls may cause damage to the air conditioner.

Winter Storage

If you plan to store the air conditioner during the winter, remove it carefully from the window according to the installation instructions. Cover it with plastic or return it to the original carton.

REMOTE CONTROLLER

Handling the Remote Controller

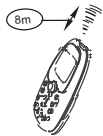

Location of the remote controller.

- Keep the remote controller where its signals can reach the unit's receiver (a distance of 8m is allowed).
- When you set timer operation, the remote controller automatically transmits a signal to the unit at the specified time. If the remote is kept in a position where signal is hindered, a time lag of up to 15 minutes may occur.

CAUTIONS

- The air conditioner will not operate if curtains, doors or other materials block the signals from the remote controller to the indoor unit.
- Prevent any liquid from falling onto the remote controller. Do not expose the remote controller to direct sunlight or heat.
- If the infrared signal receiver on the indoor unit is exposed to direct sunlight, the air conditioner may not function properly. Use curtains to prevent the sunlight from falling on the receiver.
- If other electrical appliances react to the remote controller, either move these appliances or consult your local dealer.

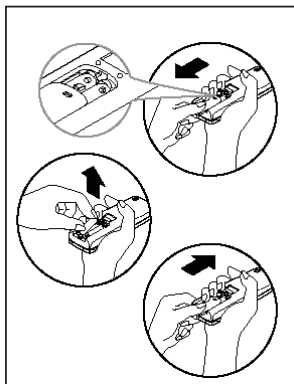

Replacing batteries

- The remote controller uses two AAA batteries (not included)
- (1) Slide the cover of the battery compartment off according to the arrow direction, then replace the old batteries with new ones.
 - (2) Insert new batteries with the (+) and (-) placed correctly.
 - (3) Replace the cover by sliding it back into position.
- After replacing batteries, set the remote controller clock.

Cautions

1. When replacing batteries, do not use old batteries or different type batteries. Otherwise it may cause the remote controller to malfunction.
2. If remote controller is not to be used for a few weeks or more, remove batteries to prevent battery leakage that may damage the remote.
3. The average battery life during normal use is approximately half a year. Replace the batteries when there is no receiving beep from the indoor unit or if the transmission indicator on the remote controller fails to light.
4. Be sure there are no barriers between the remote controller and the receiver of indoor unit.
5. Keep the Remote Controller away from all liquids.
6. Protect the Remote Controller from high temperatures and exposure to radiation.
7. Use curtains to prevent direct sunlight on the indoor receiver.
8. Keep controller away from EMI (Electro-Magnetic Interference) supplied by other household appliances.

NOTE:

- Buttons design is based on typical model and might be slightly different from the actual one you purchased, the actual shape shall prevail.
- When there are wide differences between Remote controller Illustration and USERS MANUAL on function description, the description on USERS MANUAL shall prevail.
- The device could comply with the local national regulations. In Canada, it should comply with CAN ICES-3(B)/NMB-3(B). In USA, this device complies with part 15 of the FCC Rules. Operation is subject to the following two conditions: (1) This device may not cause harmful interference, and (2) this device must accept any interference received, including interference that may cause undesired operation.
- This equipment has been tested and found to comply with the limits for a Class B digital device, pursuant to part 15 of the FCC Rules. These limits are designed to provide reasonable protection against harmful interference in a residential installation. This equipment generates, uses and can radiate radio frequency energy and, if not installed and used in accordance with the instructions, may cause harmful interference to radio communications. However, there is no guarantee that interference will not occur in a particular installation. If this equipment does cause harmful interference to radio or television reception, which can be determined by turning the equipment off and on, the user is encouraged to try to correct the interference by one or more of the following measures:
 - Reorient or relocate the receiving antenna.
 - Increase the separation between the equipment and receiver.
 - Connect the equipment into an outlet on a circuit different from that to which the receiver is connected.
 - Consult the dealer or an experienced radio/TV technician for help.
 - Changes or modifications not approved by the party responsible for compliance could void users authority to operate the equipment.

SPECIFICATIONS

Rated voltage: 3.0V (dry batteries R03/LR03 x 2)
Lowest voltage of CPU emitting signal: 2.0V
Transmission distance: 8m
Environment: -5°C/-41°F ~ 60°C/140°F

Features of remote control

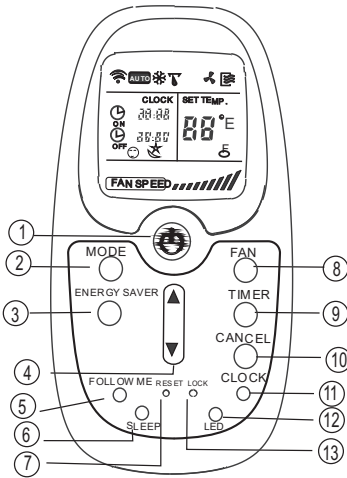

1. ON/OFF Button: Push this button to start operation, push again to stop operation.

NOTE: unit automatically initiates Energy Saver function when operating under Cool, Dry and AUTO modes.

2. MODE Select Button: Press to select desired operation mode: AUTO - COOL - DRY - FAN.

3. ENERGY SAVER Button: Press to activate the Energy Saver feature. Press again to stop the function. Refer to page 10 for details.

4. TEMP/TIME Button \blacktriangle : Push the \blacktriangle button to increase temperature setting or to adjust the TIMER in a clockwise direction. Push the \blacktriangledown button to decrease temperature setting or to adjust TIMER in a counter-clockwise direction.

NOTE: Press and hold \blacktriangle and \blacktriangledown buttons simultaneously for 3 seconds will change temperature scale display between °C and °F.

5. FOLLOW ME Button: Push to start or stop the Follow Me feature. Refer to page 10 for details.

6. SLEEP Button: Press to active SLEEP mode. this function is available for COOL or AUTO modes only. Refer to page 10 for details.

NOTE: SLEEP function will be cancelled if any of these buttons is pressed: ON/OFF, FAN SPEED, SLEEP or MODE.

7. RESET Button: This is a recessed button. Once pressed, all current settings will be cancelled and returns to default.

8. FAN Button: Used to select Fan Speed: AUTO, LOW, MED or HIGH.

9. TIMER Button: Push to activate the Auto-Start or Auto-Stop program.

10. CANCEL Button

(a) If TIMER ON, TIMER ON-OFF or TIMER OFF-ON is set, press CANCEL will override Timer program and turn off the unit.

(b) If TIMER OFF is set, press CANCEL will cancel timer setting and turn on the unit.

(c) If there are no timer settings, pressing this button will have no action.

11. CLOCK Button: Used to set the time.

12. LED Button: Press this button to clear the display on the air conditioner, press again to activate.

13. LOCK Button: Press to lock all current settings, prevents accidental changes. When locked, all buttons except LOCK are invalid. Press again to cancel lock mode.

Indicators on the Remote Controller

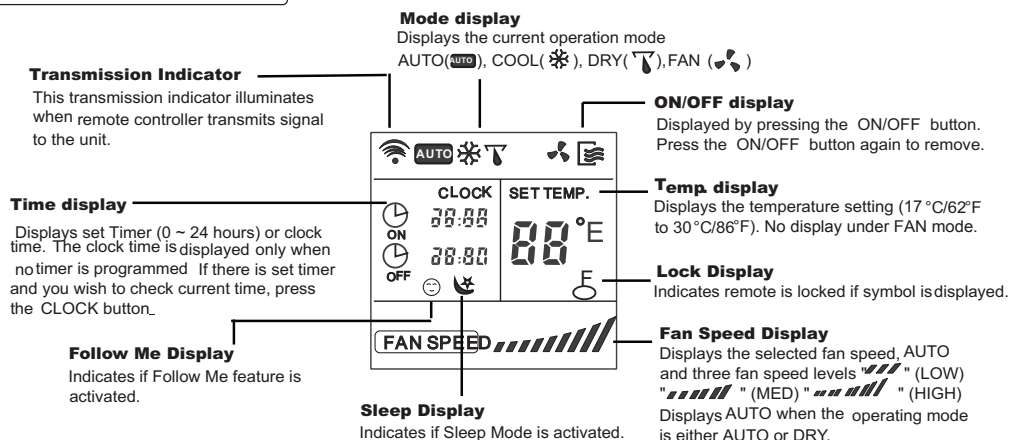

Note:
All displays on the remote controller are shown for illustration purposes only

Using the Remote Controller

SETTING THE CLOCK

Before you start operating the air conditioner, set the clock on the remote controller. The clock panel on the remote controller will display time regardless if air conditioner is in use or not.

Initial Setting of the Clock

After batteries are inserted in the remote controller, the clock panel will display "12:00". Press and hold the CLOCK button for 3 seconds, display will begin to flash.

1. Press UP/DOWN buttons to set time. Each press is in increment of one minute. Press and hold to set in 10 minute increments.
2. **CLOCK button:** Once the correct time is achieved. Press the CLOCK button or release the UP/DOWN buttons and wait 5 seconds. Clock is registered and stops flashing.
3. To readjust the Clock: Press and hold the CLOCK button on the remote controller for 3 seconds, the clock display time will start to flash. Repeat steps 1 and 2.

Note: Clock time must be set before any timer can be programmed. If clock is adjusted after programming timer, the remote controller will send the readjusted timer information to the unit.

* Clock accuracy is within 15 seconds per day.

▲ CAUTIONS

Static electricity or other factors (in case of extremely high voltage) can cause clock to initialize. If this occurs (flashing "12:00"), readjust the clock before you start operation.

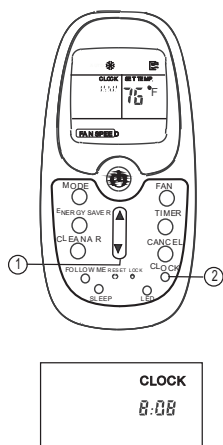

AUTO MODE

When the air conditioner is set in AUTO mode, it will automatically select cooling or fan operation depending on the set temperature and the ambient room temperature.

This unit is equipped with microcomputer memory. Once set, these operating conditions are saved and unit will operate at these conditions when you simply push the ON/OFF button of the remote controller.

Start

Ensure the unit is plugged in and power is available. The OPERATION indicator on the display panel of the unit is flashing.

1. Press MODE button to select AUTO.
2. Press the UP/DOWN button to set desired temperature. Suggested temperature range is 21°C/70°F to 28°C/82°F.
3. If the remote controller is off, push ON/OFF button to start the unit.

Stop

Push ON/OFF button to stop the unit.

Note:

If AUTO mode is not comfortable for you, select the desired mode and set temperature manually. In Auto mode, fan speed cannot be changed.

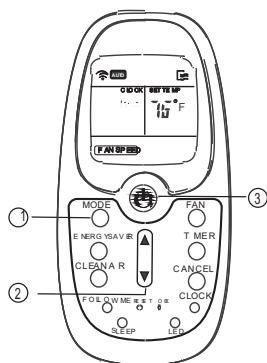

COOLING & FAN MODE

Ensure unit is plugged in and power is available.

1. Press MODE button to select COOL or FAN.
2. Press the UP/DOWN button to set desired temperature. Most comfortable temperature range is between 21°C/70°F to 28°C/82°F.
3. Press FAN to set fan speed: AUTO, LOW, MED or HIGH.
4. If the remote controller is off, push ON/OFF to start the air conditioner.

Note:

- In Fan mode, temperature setting is not available, only steps 1,3 and 4 can be performed.

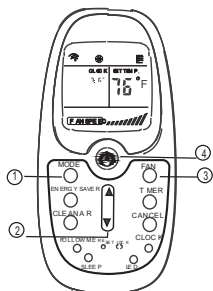

DRY MODE

Ensure unit is plugged in and power is available.

1. Press MODE button to select DRY.
2. Press the UP/DOWN button to set desired temperature. Most comfortable temperature range is between 21°C/70°F to 28°C/82°F.
3. If the remote controller is off, push ON/OFF to start the air conditioner.

Note:

- Fan speed cannot be adjusted under Dry mode.

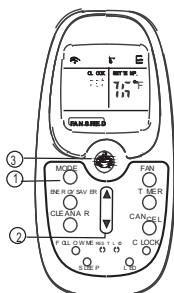

TIMER OPERATION

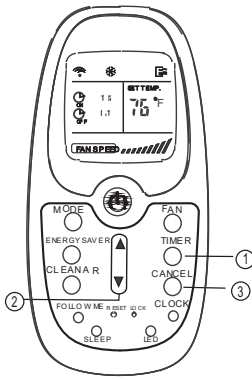

1. Press TIMER button and remote will display 0.0 and either TIMER ON or TIMER OFF indicator will flash.
2. Press the UP/DOWN button to set desired time.
Press or hold the button to set time in 0.5 hour increments, up to 10 hours; then in 1 hour increments up to 24 hours.
The set time will register 3 seconds after setting.
Once set, the TIMER ON or TIMER OFF indicator on the display panel will be illuminated.

- Canceling
3. Press CANCEL to cancel any timer setting

Note: Perform steps 1 and 2 to make changes.

▲ CAUTION

- When timer is set, the remote controller transmits the timer signal to the unit at a specified time. Keep the remote controller in a location from which it can transmit the signal properly.
- Timer setting is limited to 24 hours.
- The time will register within a 3 second period (after releasing UP/DOWN button), keep pressing until the desired time is established. Otherwise, you must repeat the steps again.

TIMER ON (To program auto start):

1. Press the TIMER button and TIMER ON indicator is displayed with time flashing.
2. Use UP/DOWN button to set the time for unit to turn on.
3. Wait 3 seconds, the time will register and stop flashing.

TIMER OFF (To program auto stop):

1. Press the TIMER button until TIMER OFF indicator is displayed with time flashing.
2. Use UP/DOWN button to set the time for unit to turn off.
3. Wait 3 seconds, the time will register and stop flashing.

COMBINED TIMER (Setting both ON and OFF timers simultaneously)

TIMER OFF → TIMER ON (unit currently running → stop → start)

This feature is useful when you want to stop the air conditioner after you go to bed or leave the house and start it again when you wake up or when you return home.

Example

- To stop the air conditioner after 2 hours and start it again in 10 hours.
1. Press the TIMER button until the TIMER OFF indicator is displayed and display time flashing.
 2. Use the UP/DOWN button to set "2.0" hours.
 3. Press the TIMER button again until TIMER ON is displayed.
 4. Use the UP/DOWN button to set "10" hours.
 5. Wait for 3 seconds for program to be registered and display time stops flashing.

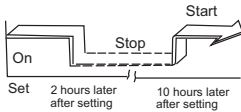

TIMER ON → TIMER OFF (unit currently off → start → stop)

This feature is useful when you want to start the air conditioner before you wake up and stop it after you leave the house.

Example

- To start the air conditioner in 5 hours and stop it after 8 hours:
1. Press the TIMER button until the TIMER ON indicator is displayed and time is flashing.
 2. Use the UP/DOWN button to set "5.0" hours.
 3. Press the TIMER button again until TIMER OFF is displayed.
 4. Use the UP/DOWN button to set "8" hours.
 5. Wait for 3 seconds for program to be registered and display time stops flashing.

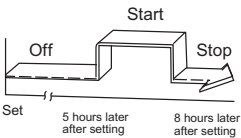
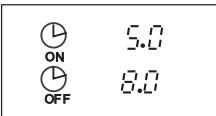

TROUBLESHOOTING TIPS

Before calling for service, review this list. It may save your time and expense. This list includes common occurrences that are not the result of defective workman-ship or materials in this appliance.

Problem	Solution
Air conditioner does not start	<p>Wall plug disconnected. Push plug firmly into wall outlet.</p> <p>Blown fuse/tripped circuit breaker. Replace fuse with time delay type/reset circuit breaker.</p> <p>Plug's current device tripped. Press the RESET button.</p> <p>Power is OFF. Turn unit ON and set to desired setting.</p>
Air from unit does not feel cold enough	<p>Room temperature is below 62°F(17°C). Unit's lowest temperature range is at 62°F(17°C).</p> <p>Temperature sensor (located behind air filter) is touching the cooling coil. Gently bend the element away from the coil.</p> <p>Set temperature has been reached, lower the set temperature.</p> <p>Compressor stopped due to mode change. Wait 3 minutes for compressor to restart.</p>
Air conditioner cooling but room is too warm - ice on the coils	<p>Outdoor temperature is below 64°F(18°C). To defrost the coil, set FAN ONLY mode.</p> <p>Air filter may be dirty, clean filter. Refer to Care and Cleaning section.</p> <p>Thermostat set too cold for nighttime cooling, set at a higher temperature.</p> <p>To defrost coil, set to FAN only mode.</p>
Air conditioner cooling, but room is too warm - NO ice on the coils.	<p>Air filter is dirty and restricting air flow. Clean air filter.</p> <ul style="list-style-type: none"> · Directional louvers positioned improperly. Position louvers for better air distribution. · Temperature is set too high, set to a lower temperature setting. · Front of unit is blocked by drapes, blinds, furniture, etc. - restricting air flow, clear blockage. · Door and/or windows are open, allowing cold air to escape. Close door and windows. <p>Unit recently turned on in a warm room, allow additional time to remove "stored heat" from walls, ceiling, floor and furniture.</p>
Unit turns on and off rapidly	<p>Dirty air filter restricting airflow. Clean air filter.</p> <p>Outside temperature is extremely hot. Set FAN speed to a higher setting to bring air past cooling coils more frequently.</p>
Noise when unit is cooling	<ul style="list-style-type: none"> · Air movement sound. This is normal . If too loud, set to a slower FAN setting. · Window vibration - poor installation. Refer to installation guide or check with installer.
Water dripping INSIDE when unit is cooling.	<ul style="list-style-type: none"> · Improper installation. Tilt air conditioner slightly to the outside to allow water drainage. Refer to installation instructions or check with installer.
Water dripping OUTSIDE when unit is cooling.	<ul style="list-style-type: none"> · Unit removing large amount of moisture from humid room. This is normal during excessively humid days.
Remote Sensor Deactivating Prematurely	<ul style="list-style-type: none"> · Remote not used within range. Use remote within 20 feet and 180° radius to front of unit. · Remote signal obstructed. Remove obstruction. · Check battery.
Room too cold	<ul style="list-style-type: none"> · Set temperature is too low. Increase set temperature.



Your Guarantee

If this product is found to be faulty as a result of faulty materials or workmanship within one year from date of purchase, it will be repaired free of charge.

This guarantee is subject to the following terms:

- Sunpentown must be notified of the fault.
- Proof of purchase must be presented to Sunpentown's nominated representative.
- The warranty will be void if the product is modified, misused or repaired by an unauthorized person.
- The warranty after repair will not be extended beyond the original one-year period.
- All replacement parts will be new or reconditioned.
- Parts, which are replaced, become the property of Sunpentown.
- The warranty applies for the use of the product in the USA only

What is NOT COVERED:

- Warranty does not include freight charges.
- Damage due to installation error, product abuse and/or misuse.
- Incidental or consequential damage caused by possible defects with this product.
- Labor cost incurred for the installation and/or removal of a possible defective unit.
- Damage to product caused by improper power supply voltage, accident, fire, floods or acts of nature.
- Failure of product resulting from unauthorized modifications to the product.
- Improper installation or failure to perform the necessary maintenance.
- Normal wear and tear on parts or replacement of parts designed to be replaced.
- Damage to personal property from use of product.
- Replacement or repair of household fuses, circuit breakers, wiring or plumbing.

This GUARANTEE is in addition to your Statutory Rights

SUNPENTOWN INTERNATIONAL INC.
14625 Clark Ave. City of Industry, CA 91745
Tel: 800-330-0388
service@sunpentown.com
www.sunpentown.com