

CATSKILL

C R A F T S M E N , I N C .

Assembly Instructions Model 15445 Heart of the Kitchen Island with Drop Leaf



READ ME FIRST!!!

You have purchased a fine piece of domestic hardwood furniture with finely matched non-warping hardwood veneer panels and shelves. Because this is a quality product, we have engineered all parts for a near-perfect fit. All parts are secured with positive fastening hardware.

At first blush when you see all of the parts and pieces of hardware, you may feel that assembly is very difficult. In fact, assembly is very easy if you follow the instructions step by step in order. A partner will cut assembly time considerably.

Here are a few general rules to keep in mind:

- 1) Because we sell to a large cross-section of the populace, we encounter people with various assembly skills and abilities. For this reason, we try to over simplify some steps; however, should you encounter any assembly difficulty, please give us a call at (607) 652-7321 Mon.-Fri. 8am - 4:30 pm EST and someone will help you. What's easy for us may not be easy for you!
- 2) Our basic assembly hardware is called bastion hardware which consists of a post that is screwed into the wooden parts; a barrel nut that has holes thru the sides and an open threaded end that accepts a set screw. Pins hold panels in place and keep braces from turning. Bastion fasteners join the front/back panel assemblies. Heads on set screws sometimes vary.
- 3) TOOLS NEEDED: Medium-sized flat blade screwdriver, a medium-sized and small Phillips screwdriver, a hammer, and a small amount of vegetable oil or liquid soap to ease screwing screws wherever hardwood is involved. A tape measure will help you identify the parts. We include an allen wrench when set screws have hex heads. A power screwdriver with flat/phillips heads will speed assembly on most applications except drawer glides and magnets/plates.
- 4) All Parts are described as if you were facing the front side of assembled unit!

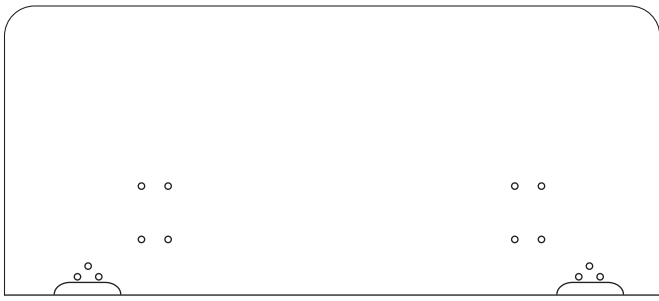

Table Top (1)
34" x 18" x 3/4"



Drop Leaf (1)
34" x 11" x 3/4"



Back Panel (1)
20 7/16" x 15 1/16" x 7/16"

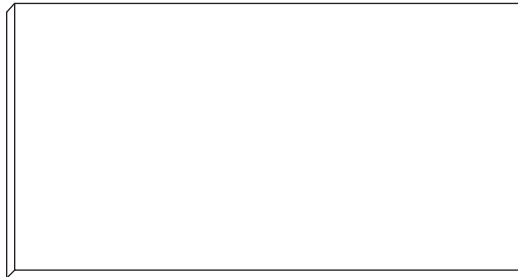

Bottom & Middle Shelf (2)
28 7/16" x 14 1/4" x 7/16"

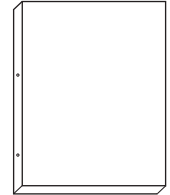

Side Panel (2)
16 5/8" x 14 5/10" x 7/10"



Bottom Front, Top Back, Middle Back,
& Bottom Back Braces (4)
20 1/2" x 2" x 3/4"

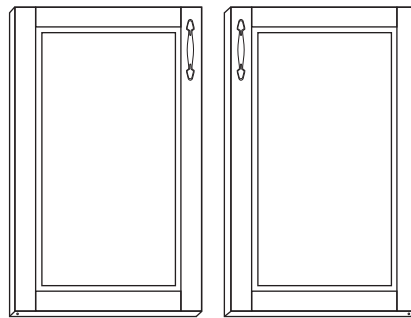

Left Door (1)
15" x 10" x 3/4"

Right Door (1)
15" x 10" x 3/4"

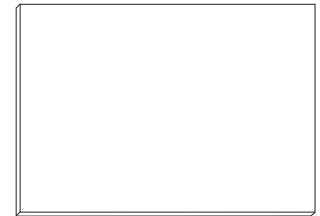

Drawer Bottom (1)
18 3/4" x 12 3/4" x 1/4"

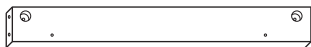

Bottom Side Brace (2)
14 3/8" x 2" x 3/4"

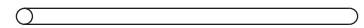

Nickel Side Rods (6)
15" x 3/8" Diameter

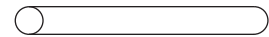

Polished Nickel Towel Bar (2)
8 7/8" x 3/8" Diameter

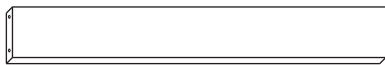

Middle Side Brace (2)
14 3/8" x 2" x 3/4"

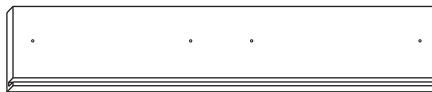

Drawer Front (1)
20 5/16" x 4 1/2" x 3/4"

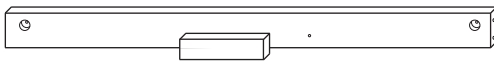

Middle Front Brace (1)
20 1/2" x 2" x 3/4"



Drawer Back (1)
19 9/16" x 3 1/2" x 3/4"

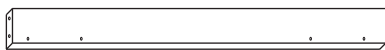

Glide Support Brace (2)
14 3/8" x 1 1/2" x 3/4"



Drawer Side Right (1)
12 1/4" x 3 1/2" x 3/4"



Drawer Side Left (1)
12 1/4" x 3 1/2" x 3/4"



Top Side Brace (2)
14 3/8" x 4 5/8" x 3/4"

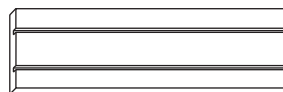

Side Shelf (2)
14 5/16" x 4" x 3/4"

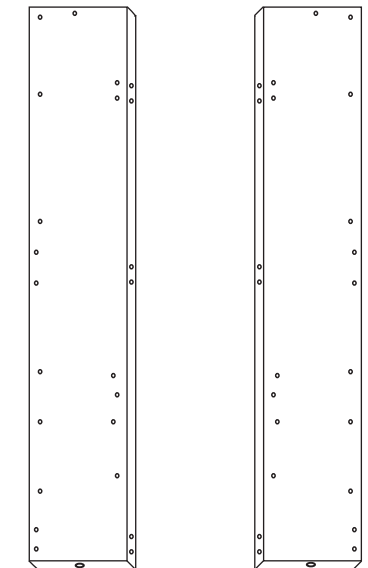



Left Back/
Right Front (2)
31" x 5" x 3/4"

Right Back/
Left Front (2)
31" x 5" x 3/4"

NOT TO SCALE

 (Drawer back)
1 1/4" Phillips Flat Head #8 Screw (4)

 (Drop Leaf Hinges)
5/8" Phillips Flat Head #8 Screw (20)

 (Brace ends)
3/4" Long 3/16" DIA. Steel Pin (46)

 (Shelf supports)
1" Long 3/16" DIA. Steel Pin (14)

 (Doors)
1 1/2" Long 3/16" DIA. Steel Pin (4)

 (Drawer Front)
Cam Posts (2)

 (Drawer handle)
1" Truss Head Machine Screw (2)



 (Door Handles)
7/8" Truss Head Machine Screw (4)

 (For "L" Brackets & Attach Glides to Cabinet)
5/8" Phillips Flat Head #7 Screw (12)
Note: 8 are loose packed, 4 are with the glide pack

 (Drawer Sides)
5/8" Phillips Flat Head #5 Screw (4)

 (Attach Handle)
1" Phillips Flat Head #6 Screw (4)

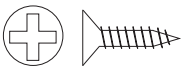
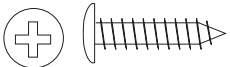
Magnet Pack

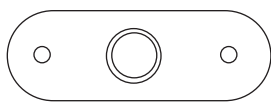
 1/2" Phillips Flat Head #4 Screw (2)	 5/8" Pan Head #6 Screw (4)
 Magnet (2)	 Magnet Plate (2)

 (18)

 (18)

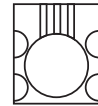

3/16" Flat Washer (2)
(Under Door Pins)

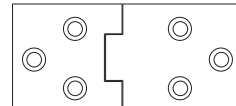
Bastion Barrel Nut (18)

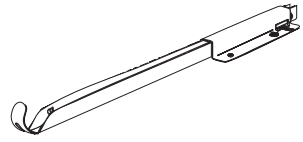

Hinge (2)

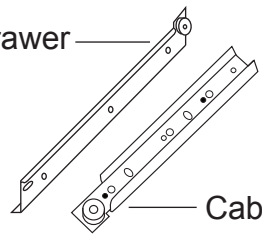
Drop Leaf Support (2)



Towel Bar Post (4)

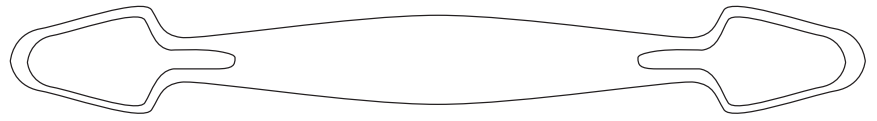

Drawer
Cabinet
14" Drawer Glide (2 Sets - 4 pcs.)

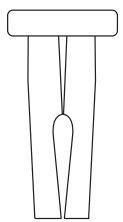

Cam (2)

Door/Drawer Handle (3)

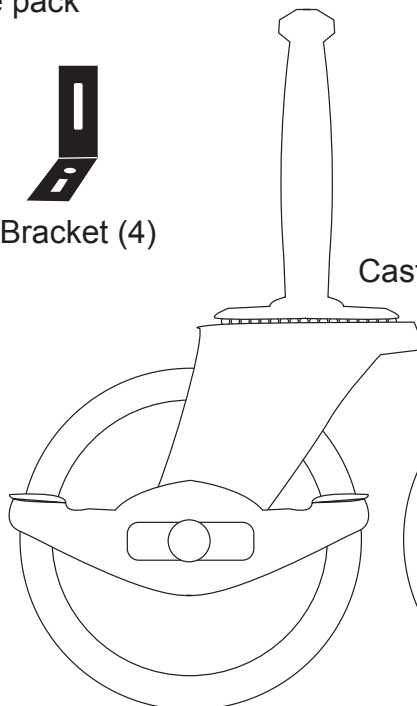
"L" Bracket (4)

Caster Socket (4)

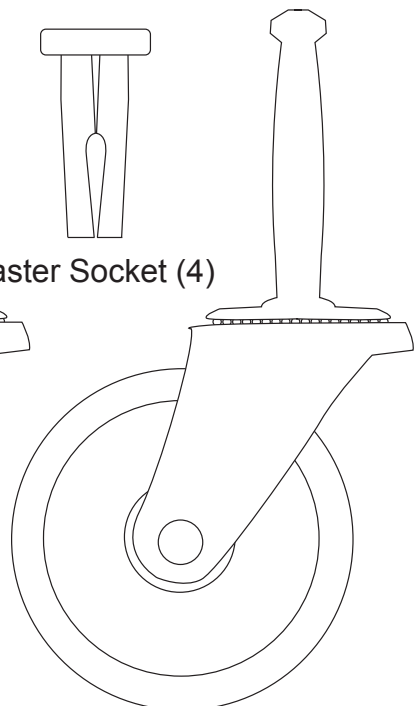
Locking Wheel Caster (2)

Non-Locking Wheel Caster (2)

STEP 1

Drawer Assembly

A. Attach the Drawer Back to the Drawer Sides with four 1 1/4" #8 screws. There are left and right sides. Make sure the slots that run the length of the Slides are aligned with the slot in the Drawer Back to accept the Drawer Bottom.

B. Slide in Drawer Bottom, best side up, to inside of drawer.

C. Screw the cam posts into the two outside holes on the inside face of the drawer front until seated. Only 3/8" of this post goes into the wood, leaving the 4 larger guide rings/head exposed. See illustration 1C. Visit our website www.catskillcraftsmen.com for a video on cams.

D. Insert the posts into holes in the drawer sides until seated against the front ends of the drawer sides. Insert cams so that the arrow on the outside face of the cam points to the post. The slot in the cam fits over the post. Turn with Phillips screwdriver until seated. Don't over-torque!! See Illustration 1C. See our video online at www.catskillcraftsmen.com

E. Attach the drawer handle with one 7/8" Truss head machine screws.

F. Attach the drawer glides (left and right) to the Drawer Sides using two 5/8" #5 screws per side. (packed separately) Wheels go toward Drawer Back and are up. Glides are flush with front ends of drawer sides and stick out about 3/4" in back.

FOR TIPS ON HOW THE CAM SYSTEM WORKS SEE LAST PAGE or visit us online at www.catskillcraftsmen.com and view our video.

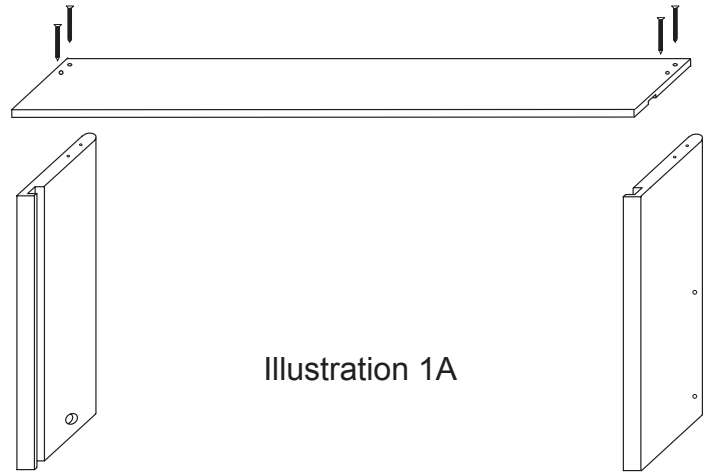

Illustration 1A



Illustration 1B

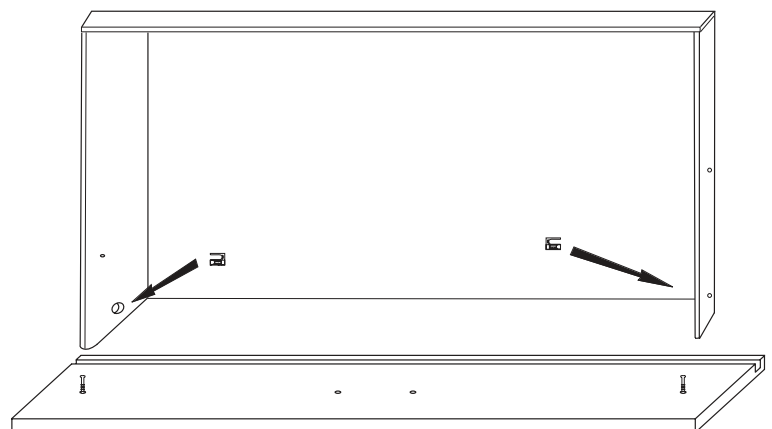

Illustration 1C

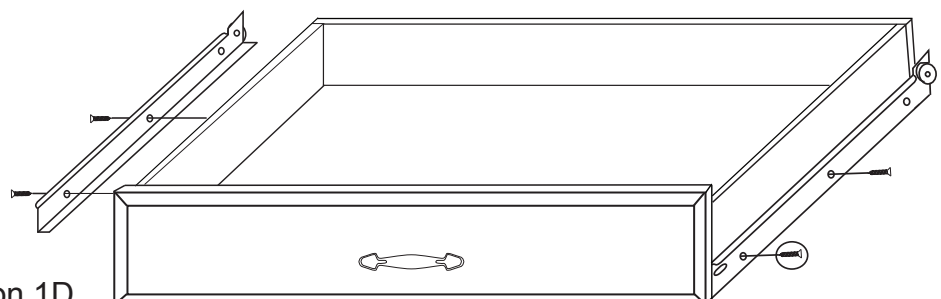

Illustration 1D

STEP 2

Attach Posts to Legs

A. There are 2 Right Legs and 2 Left Legs. Diagonal legs are the same (Example: Right Front/Left Back). For identification purposes look at illustration 2 which shows the inside view of a pair of legs.

B. Take all 4 legs and lay out in pairs as in illustration 2. The posts will go inside edge hole #1 (top), hole #3 down from top, and hole #6 (last). **On the front legs use holes #3 and #6 only.** Put a few drops of vegetable oil into these holes or dip post threads to ease screwing of posts into place.

C. Attach two posts to the inside flat face of each leg, using the top and bottom outside holes as illustrated.

FOR TIPS ON HOW THE BASTION FASTENING SYSTEM WORKS SEE LAST PAGE!!!

NOTE: The holes in the posts on the inside edges will be perpendicular to the long edges of the leg when properly seated, as pictured in illustration 2. The holes in the posts on the flat surfaces will be parallel with the short edges of the legs when properly seated

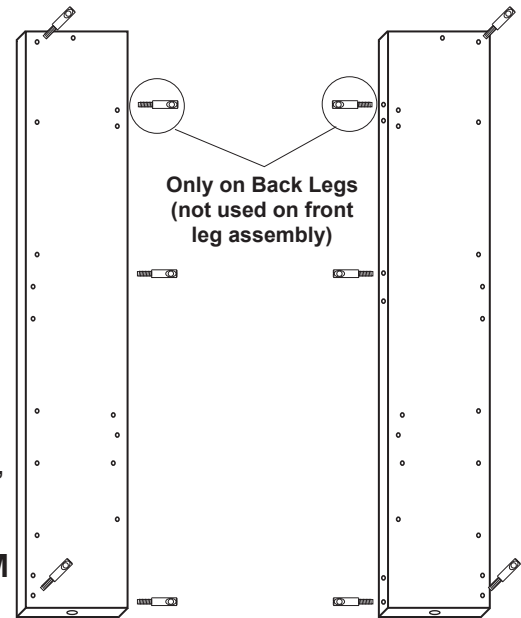

Left Back/Right Front Right Back/Left Front

STEP 3

Brace Guide

Identify and group like braces together.

A. The Middle Front, Bottom Front, Middle Back and Bottom Back Braces are exactly the same, except the Middle Front Brace has a magnet block attached. Brace size 20 1/2" long x 2" wide.

B. The Top Side Braces are 14 3/8" long x 4 5/8" wide. The Middle Side Braces are identical, are 14 3/8" long x 2" wide with no holes on the flat surfaces. The Bottom Side Braces are identical, are 14 3/8" long x 2" wide but have pin holes and nut access holes on inside flat face. The Glide Support Braces are 14 3/8" x 1 1/2" wide with 2 pin holes on each end & 4 holes on bottom inside.

C. Insert/tap 3/4" steel pins into the ends of ALL braces. If tight, DON'T OVERDRIVE PINS. About 3/8" of pin will stick out when seated. Since the diameter of holes/pins vary from time to time, some pins will be looser than others. This is not a problem!

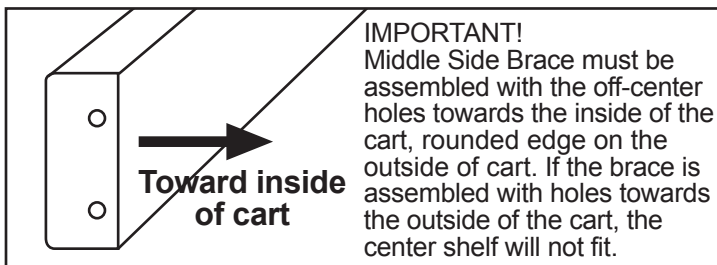
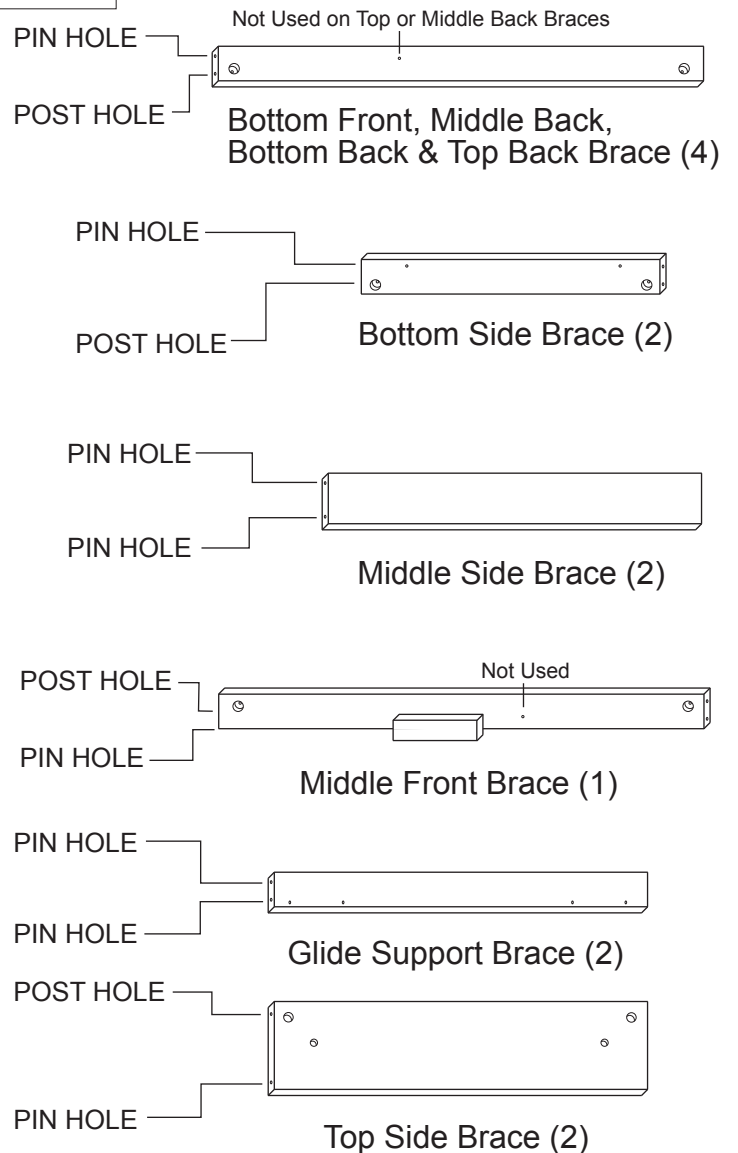

Illustration 3

Illustration 2



STEP 4

Assemble Cabinet Sides – (We recommend using a second person to help with alignment)

A. Lay a Right Back/Left Front Leg on its back and attach the Top Side Brace to the upper left corner using the bastion posts and steel pins. Also attach the Middle Side Brace and Bottom Side brace in like manner. Now slip in the Side Rods into the big holes and fit in the Glide Support Brace into the upper right side so the holes are down and toward the bottom of the brace. Then fit the side panel on the right side of the back leg using 3/4" pins. Make sure that the holes in the braces face the side panel and glide support. This should now look like illustration 4A.

B. Now take a Left Back/Right Front Leg and fit it onto the assembled unit using bastion post/pins. Now it should look like illustration 4B.

C. Assemble the other side by repeating steps A & B.

Note: Some people find it easier to place the leg flat on its face with the holes up. See assembly video.

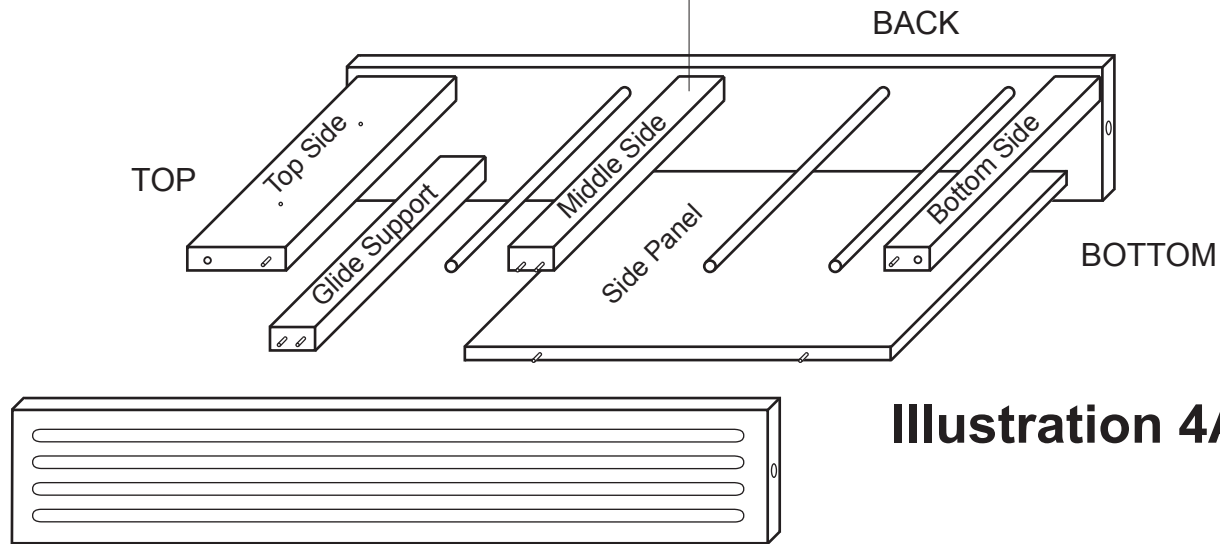
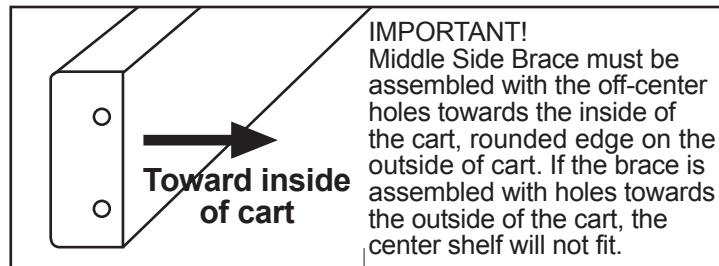
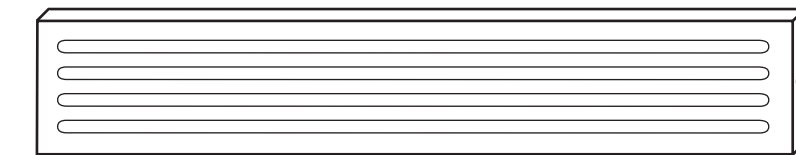

Illustration 4A



FRONT

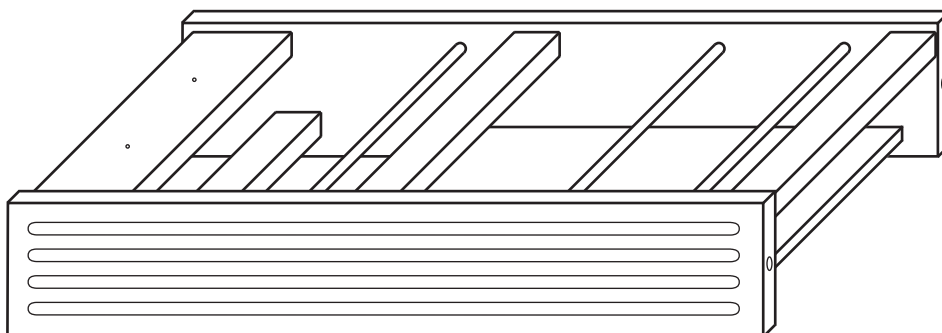

Illustration 4B

STEP 5

Back Assembly

A. Lay the left side unit as in illustration 5 and attach the top Back Brace using the bastion post/pins. Now fit the Back Panel between the Bottom Back Brace and Middle Back Brace using 3/4" steel pins, and then attach it to the side unit using bastion posts/pins. See illustration 5

B. Attach the Left Cabinet Glide to the Glide Support Brace with 5/8" #7 flat head screws. The glides look almost alike however, the right glide (as you face the cart) has a rolled lip at the top of the glide that keeps the drawer glide wheel in place. Line up the holes in the the glides so that the end with the wheel comes flush with the edge of the leg.

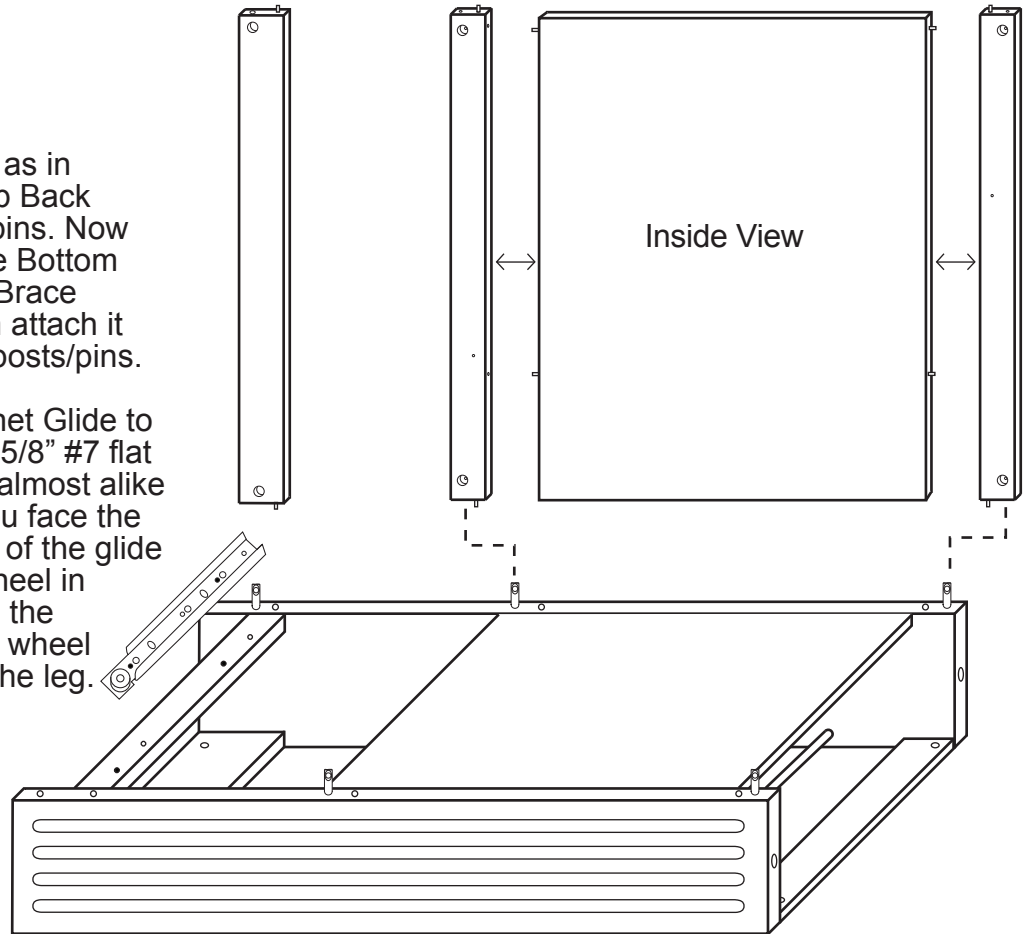

Illustration 5

STEP 6

Front Assembly

A. Tap 1 1/2" pins into the ends of the doors and fit both doors between the Middle Front Brace and Bottom Front Brace using pins as shown in illustration 5 but put washers on pins on the bottom of the doors.

B. Now attach the braces to the side unit using bastion posts/pins as in illustration 5/6.

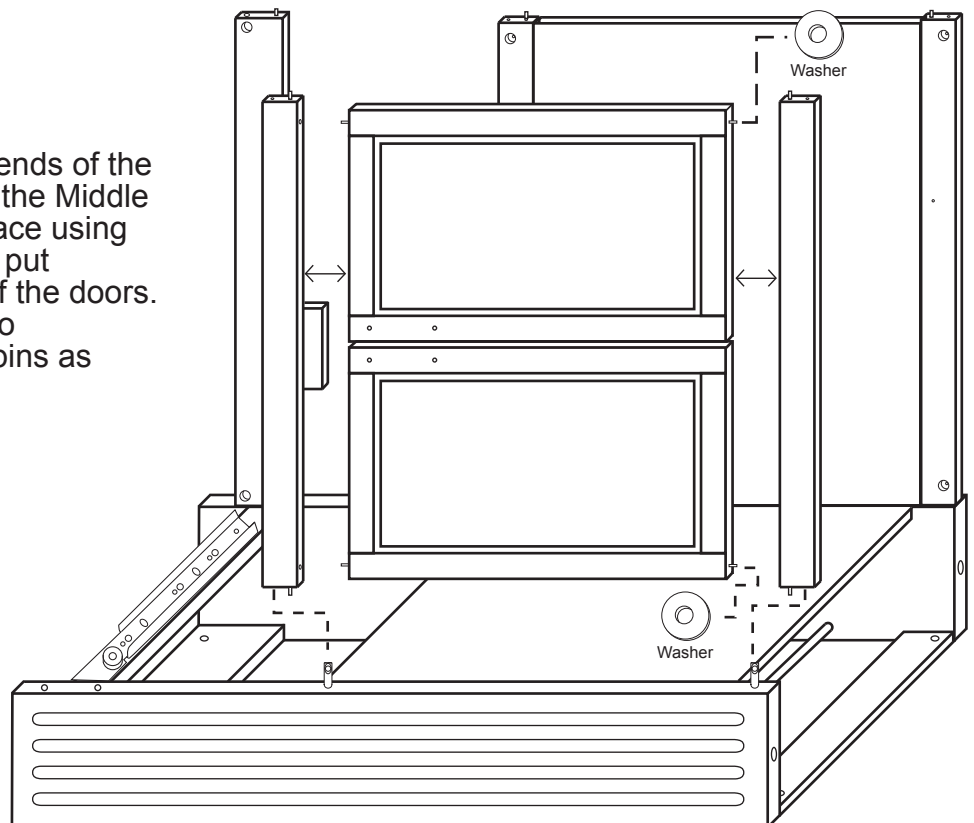

Illustration 6

STEP 7

Main Assembly

A. Attach the right cabinet glide to the glide support brace on the right side unit using the same holes as in step 5B.

B. Take the right side assembly and attach it to the main unit using the bastion system.

NOTE: There are 3 posts in the back legs, only 2 in the front legs (top holes not used on front legs)

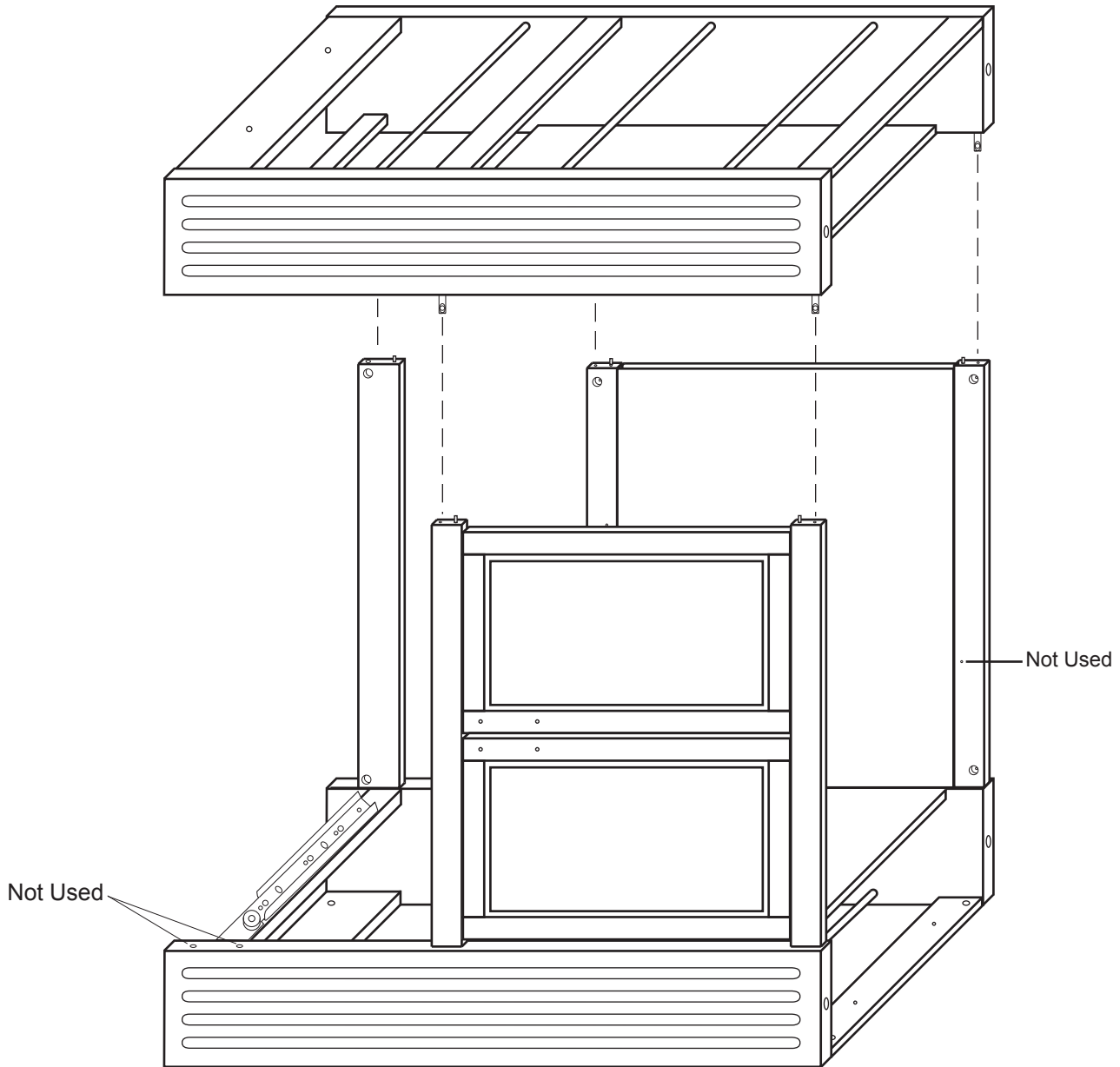

Illustration 7

STEP 8

Bottom Assembly

A. With unit still on its side place bottom shelf into the bottom of the cart as in illustration 8. Secure by tapping 1" pins (6), 2 in each bottom side brace and 1 each for the front/back bottom braces.

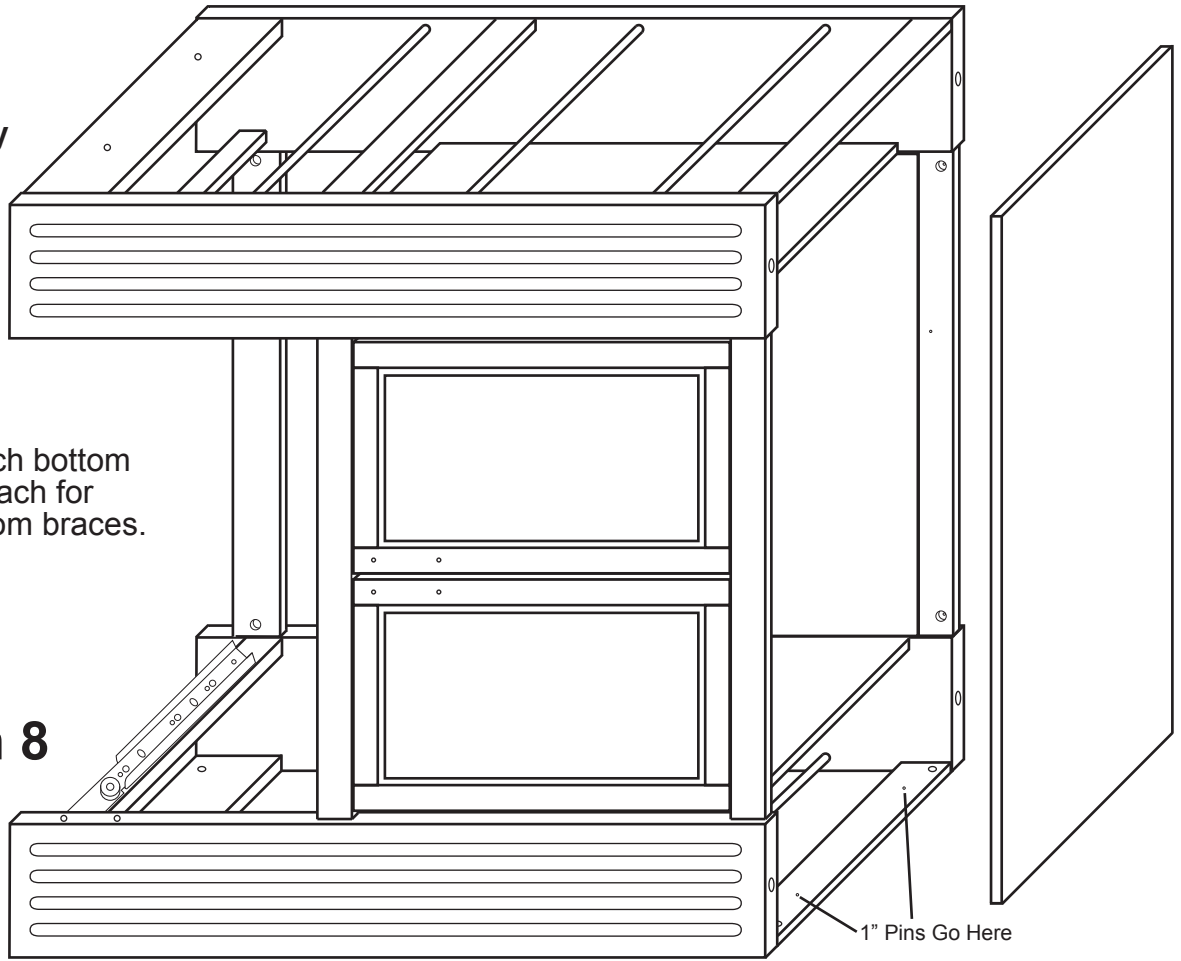

Illustration 8

STEP 9

Caster/Towel Bar Assembly

A. Tap wheel sockets into 3/8" holes in leg bottoms. Hammer until socket is seated.

B. Locking wheels in front, tap in wheels with a hammer, hitting on solid fixed metal until wheel is seated. See illustration 9.

C. Upright and attach the handle/Towel bars to the Top Side Braces using 1" #8 screws from inside the Top Side Brace.

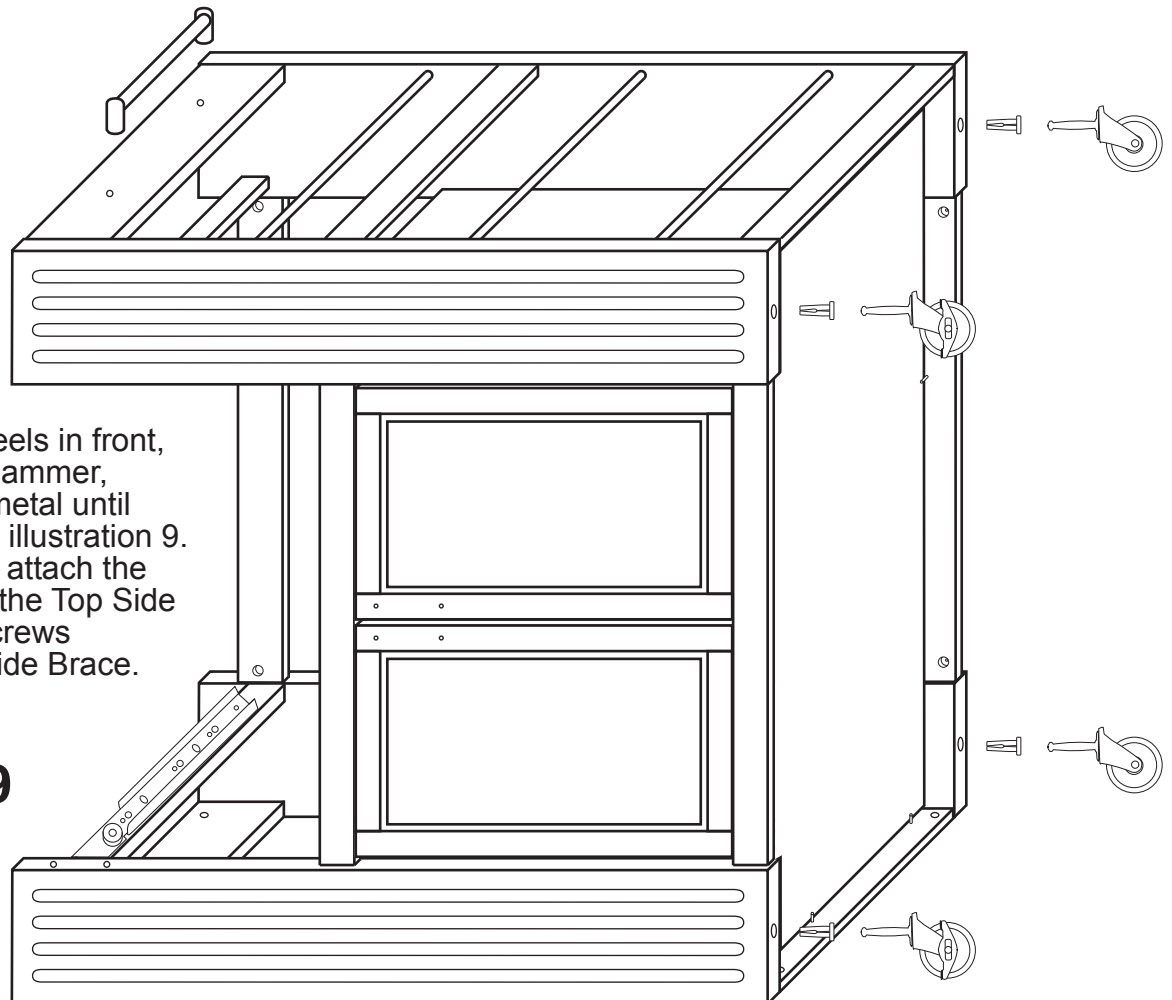
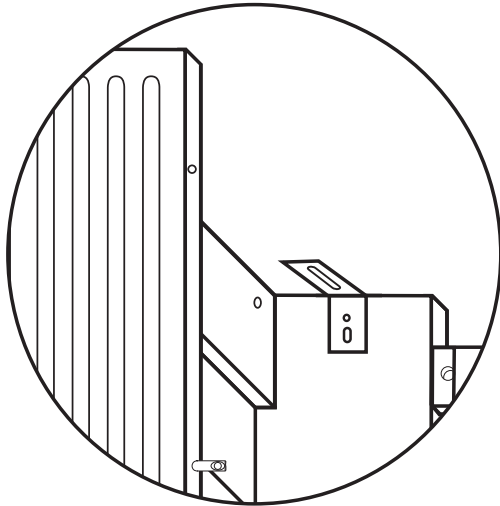

Illustration 9

STEP 10

Top Assembly

- A. Upright unit and attach an "L" Bracket to the top inside of each leg using 5/8" #7 Phillips head screws. The screws go through the round hole in the "L" Bracket.
- b. Attach the drop leaf supports and hinges to the Table Top and Drop Leaf using 5/8" #8 screws.



Brace and glide removed in illustration 10A to show placement of "L" Bracket

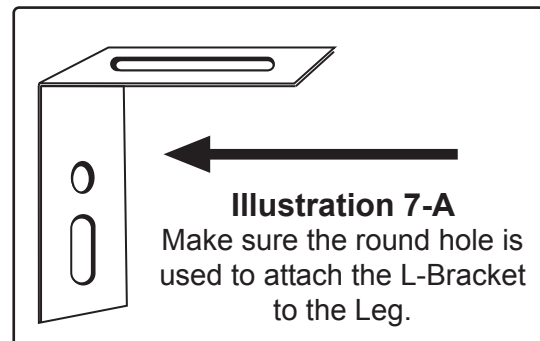

Illustration 10A

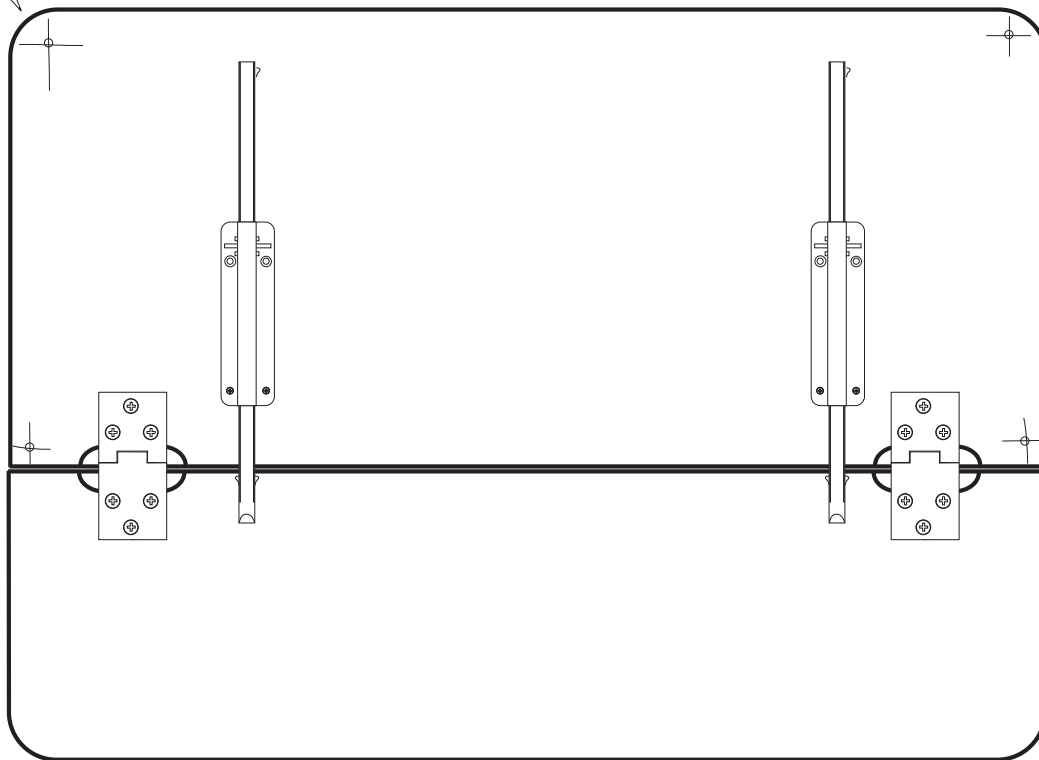

Illustration 10B

- A. Mark a cross over the pilot holes as illustrated in Illustration 10B. This helps to line up the pilot holes when placing the top on the cabinet.

STEP 11 (This step can also be accomplished without the unit upright)

Top Assembly

- A. Invert cabinet onto top and secure cabinet to the top using 5/8" #7 screws through the "L" brackets on the legs, or place cart top on top of cabinet as in illustration 11.
- B. Insert/tap 1" pins into legs and drop side shelves onto pins, 4 pins for each side shelf.
- C. Slide middle shelf into place on top of side panels though one side. Insert drawer.

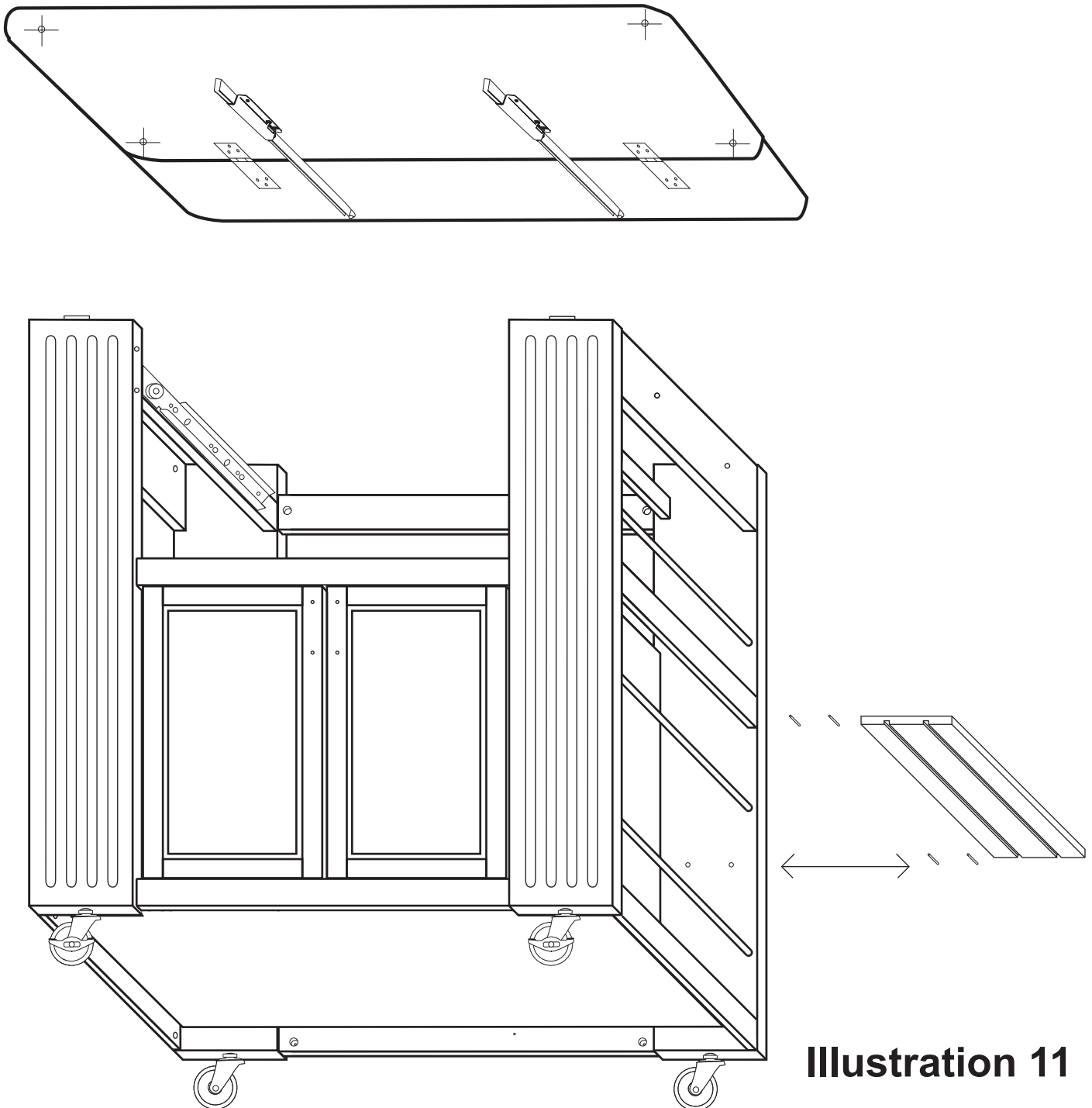

Illustration 11

STEP 12

Magnet Block Assembly

A. Attach the magnet plates (may be stuck to magnet!) with 1/2" Phillips flat head #4 screws to the inside top of both doors. The countersunk hole in the plate faces out/bumps go toward wood. See illustration 12B.

B. Attach metal door handles with 1 8/32" truss head machine screws as in illustration 12A.

C. Stick magnet to magnet plate on right door.

D. With left door open, close the right door. The magnet should be positioned over the wooden block on the bottom of the Top Front Brace. Hold the magnet in place with your thumb, and open the right door. The magnet will be in the correct position on the block.

E. Secure magnet with the two round head screws in the magnet packet as in illustration 12 C. Center screws in the slots in the magnets. This will allow adjustment later, if needed. There are no pilot holes as blocks are soft wood.

F. Repeat with left door.

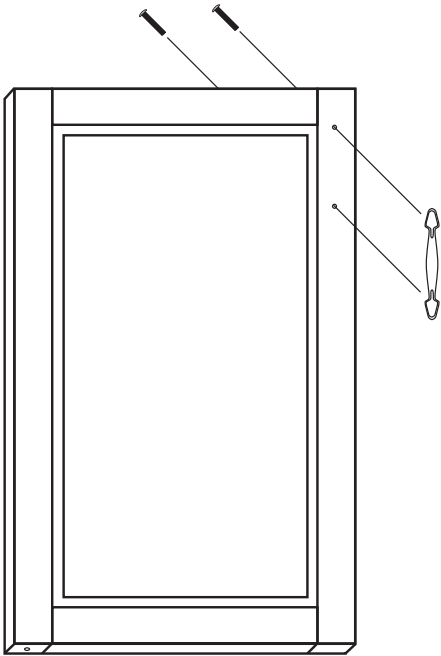

Illustration 12A

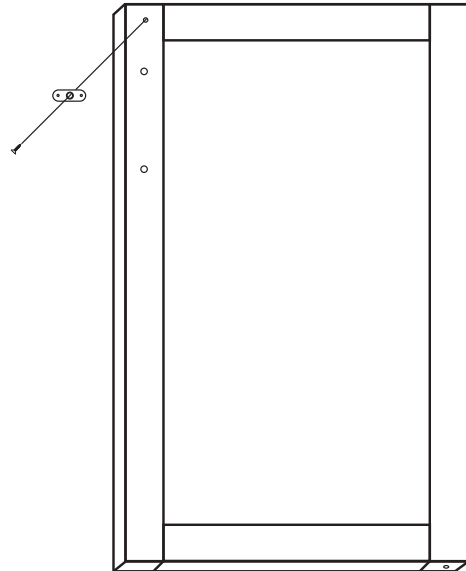

Illustration 12B

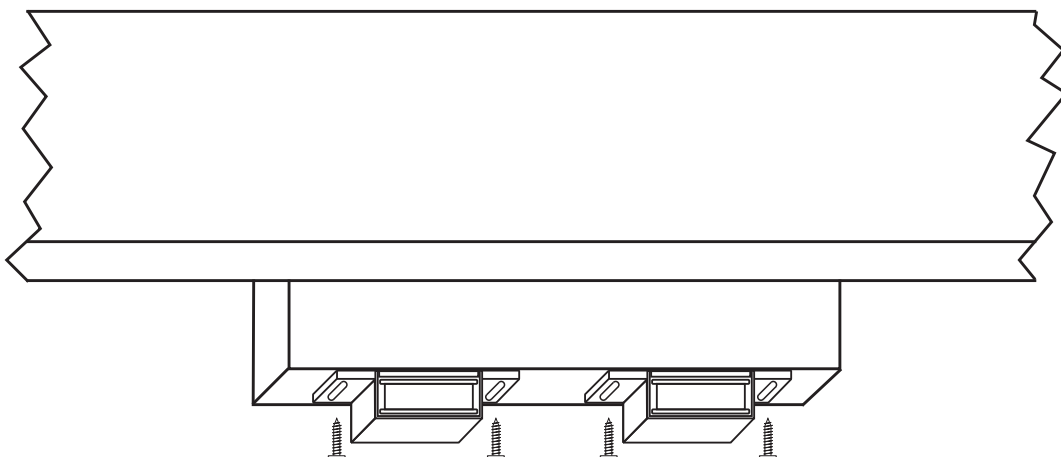

Illustration 12C



For continued beauty and long life of your Catskill Craftsmen cart, we recommend Catskill Craftsmen's Butcher Block Oil.

If you would like to purchase Butcher Block Oil directly from Catskill Craftsmen's factory, we offer a reduced price. For one eight ounce (8 fl. oz.) bottle, which is sufficient for two applications, simply send \$6.95 along with the completed coupon to the address below or visit us online at www.catskillcraftsmen.com for other ordering options.



Catskill Craftsmen, Inc.
15 West End Ave.
Stamford, NY 12167-1296

CATSKILL
CRAFTSMEN, INC.

BUTCHER BLOCK OIL COUPON

Please send me _____ # of bottle(s) of the Catskill Craftsmen Butcher Block Oil at \$6.95. My Check or Money Order is enclosed for a total of \$_____.

Item Code: 15445

NAME _____

ADDRESS _____

CITY _____

STATE _____ ZIP _____

Please make checks payable to: Catskill Craftsmen Inc.
15 West End Ave. Stamford, NY 12167-1296

TIPS ON HOW THE BASTION FASTENING SYSTEM WORKS

1. The Bastion fastening system consists of a steel post (threaded on one end with a hole through the shaft on the other end); a Barrel Nut (cylindrical barrel-shaped with threaded open end & holes through the sides); and a Set Screw (Phillips slot on one end, pointed on the other)

2. To attach Posts: A) Dip threads of Post in vegetable oil. B) Align threaded end of Post with hole in wood, tap on slotted end with hard hammer until threads enter, then tighten down using a flat head screw driver or the provided allen wrench (See the Illus. Bas. 3 for alternate seating methods). **DO NOT TRY TO HAMMER THE POST ALL THE WAY IN AS IT WILL STRIP THE POST HOLE.** C) When solid shaft of Post hits wood, back out approximately ½ turn until the hole in the posts is properly aligned as per step by step directions. For example: the holes in the posts on the inside of the drawer front will be parallel with the long length of the drawer front when properly seated.

3. A) Place a Barrel Nut into the nut access hole, so that the threads in the nut face out. The small notches on either side of the nut opening, indicate the location of the holes through the sides of the nut. B) Insert the posts through the end of the braces (or drawer sides); through the holes in the sides of the nut. When properly aligned, you will see the hole in the post inside the barrel nut. Post hole should be slightly off-center toward the wood.

4. Insert the Set Screw into the threaded end of the nut and tighten down. The tip of the Set Screw will seek the center of the hole in the Post as it is tightened down, forcing the Nut toward the main shaft of the Post. This is what tightens the wooden parts together. Set screws should thread easily – **DON'T CROSS THREAD!** If Set Screw doesn't thread easily, check position of the hole in Post.

5. If the wooden parts are not tight against each other, the Post needs to be screwed a half turn at a time until wood joints are tight.

Illustration Bas. 1

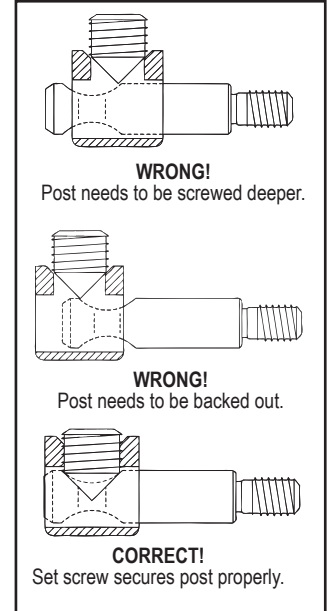
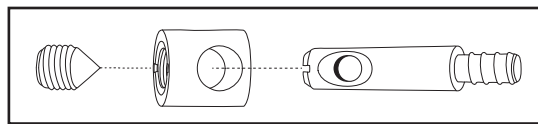
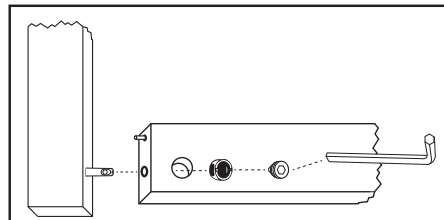

Illustration Bas. 2



Step 2



Allen Wrench Provided

Step 1

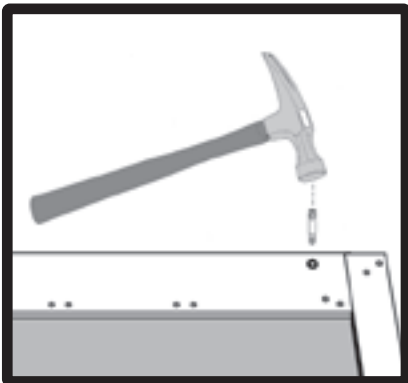
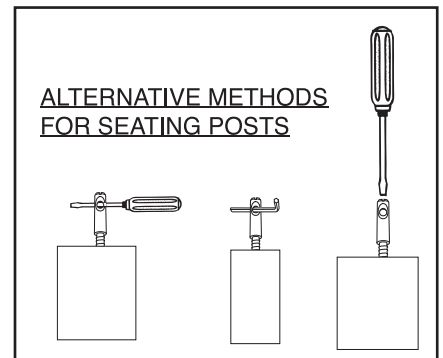

Illustration Bas. 3



See video on our website!

If you have any questions regarding assembly or missing or damage parts, call our customer support number:

607-652-7321 or 888-732-7321.

Customer Support Hours are 8am-5pm Mon. - Fri. Eastern Time zone.