

Recommended Maximum Weight

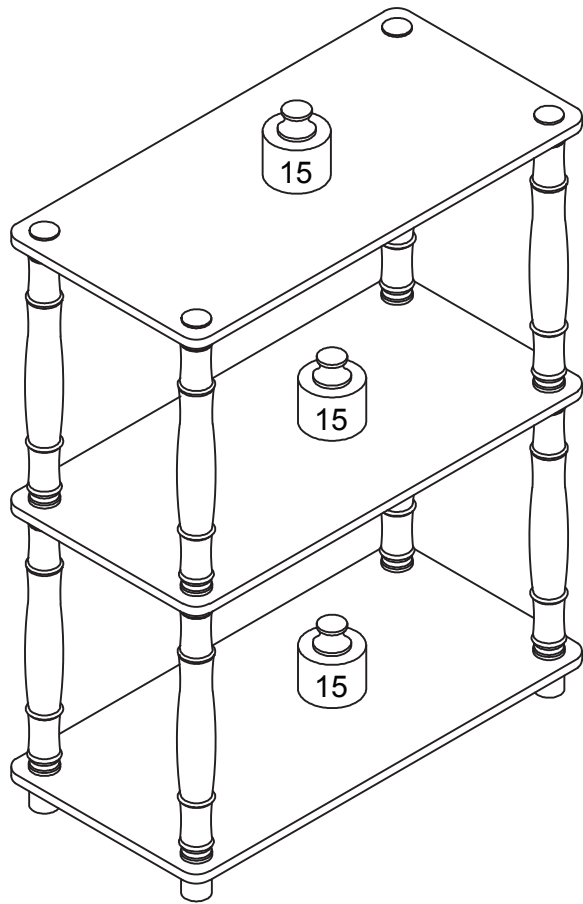

**WARNING:**

>This unit has been designed to support the maximum loads shown. Exceeding these load limits could cause sagging, instability, product collapse, and/or serious injury.

>DO NOT allow children to climb on unit.

>Put heavier items on lower shelves.



**Assembly Instruction**

Furinno 3-Tier Compact Multipurpose Tube Shelf Display Rack

MODEL : 18029

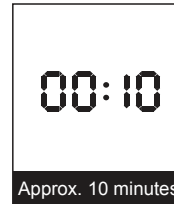

Approx. 10 minutes

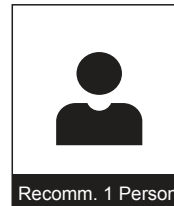

Recomm. 1 Person

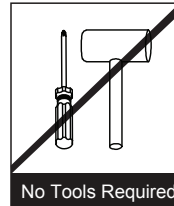

No Tools Required

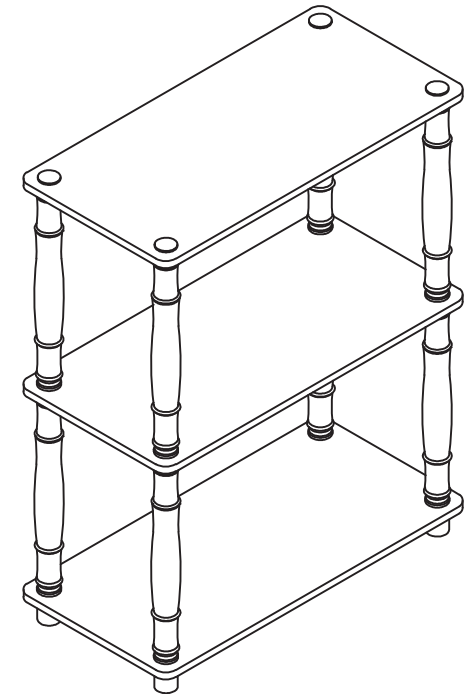





**Customer Support**

**NEED HELP?** For replacement requests or product inquiries, please contact our Customer Service Team by emailing us at [support@furinno.com](mailto:support@furinno.com). Thank you for selecting Furinno!

[www.furinno.com](http://www.furinno.com)



No	Hardware List	Qty
1	Pole 	8pcs
2	Cap 	4pcs
3	Round Leg 	4pcs

No	Parts List	Qty
A	Shelf 	3pcs

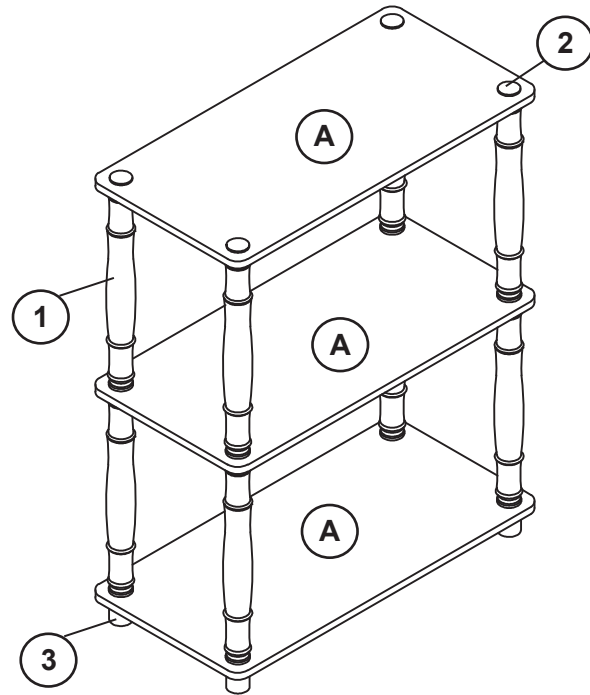

**USEFUL HINTS BEFORE YOU START:**

1. Read each step carefully before starting.
2. It is important that each step is performed in correct order to avoid difficulties.
3. Identify, sort and count the parts before assembly.
4. Assemble your furniture on packaging cardboard to prevent scratch or damage.
5. Clean the product with mild cleanser using soft damped cloth. Do not use harsh or abrasive cleanser.
6. Using incompatible hardware might cause damage to product.

**STEP 1**

- 1.1 Attach Round Leg (3) to the bottom of Shelf (A) and tighten with Pole (1), as shown.
- 1.2 Attach center Shelf (A) and tighten with Pole (1).

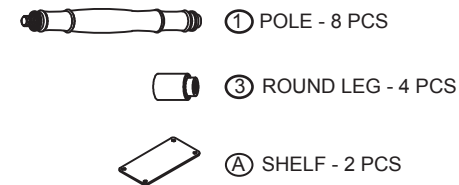
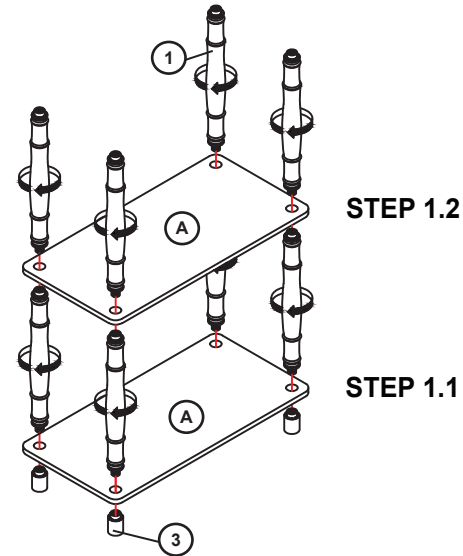

**STEP 2**

- Tighten Cap (2) on the top Shelf (A), as shown.

