

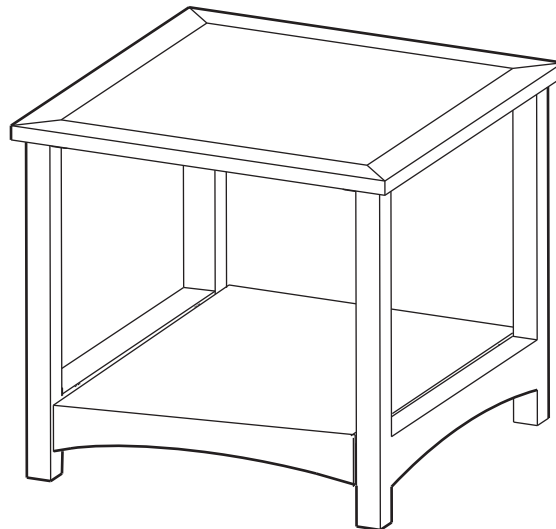

Item #635-614
Model #143-002-22ET-V2

USE AND CARE GUIDE

MILL VALLEY 22 in. GLASS TOP END TABLE



Questions, problems, missing parts? Before returning to the store,
call Hampton Bay Customer Service
8.00 a.m. - 6.00 p.m., EST, Monday - Friday

1-855-HD-HAMPTON

HAMPTONBAY.COM

THANK YOU

We appreciate the trust and confidence you have placed in Hampton Bay through the purchase of this end table. We strive to continually create quality products designed to enhance your home. Visit us online to see our full line of products available for your home improvement needs. Thank you for choosing Hampton Bay!

Table of Contents

Table of Contents.....	2	Pre-Assembly	3
Safety Information.....	2	Planning Assembly	3
Warranty	2	Hardware Included.....	3
2 Year Frame and Weave Limited Warranty.....	2	Package Contents	4
What Is Covered	2	Assembly	5
What Is Not Covered	2		
Care Instructions	2		

Safety Information



DANGER: Please keep children out of the assembly area during assembly.



WARNING: Do not stand or sit on the table. Do not put heavy objects on the table.



CAUTION: Use the table on flat ground only. Handle with care as glass top is fragile.

Warranty

TWO YEAR FRAME AND WEAWE LIMITED WARRANTY

WHAT IS COVERED

We warrant the frame and weave to be free of manufacturing defects to the original purchaser for two years.

WHAT IS NOT COVERED

It remains the customer's responsibility for freight and packaging charges to and from our service center. This warranty does not cover commercial use, hardware, acts of nature, fire, freezing and abusive use. In addition, purchased parts are not covered under this warranty. We reserve the right to make substitutions with similar merchandise, if the model in question is no longer in production.

Care Instructions

Before using, wipe with a clean, dry cloth. Do not use bleach or solvents. Treat the frame with a one-step liquid wax for maximum protection light and salty, damp air. When not in use, store the furniture in a cool, dry place. When cleaning the tabletop make sure to use a soft, clean cloth that doesn't bleed color as well.

You may contact our customer service department with any questions by phone at 1-855-HD-HAMPTON or visit www.hamptonbay.com.

Pre-Assembly

PLANNING ASSEMBLY

It will take one person about 15 minutes to complete the assembly process.

HARDWARE INCLUDED



NOTE: Hardware not shown to actual size.

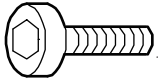

AA

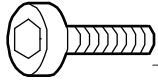

BB

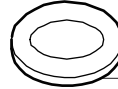

CC

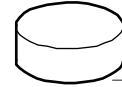

DD



EE

Part	Description	Quantity
AA	Bolt (M6x20)	8
BB	Bolt (M6x35)	4
CC	Washer	12
DD	Bolt cap	12
EE	Hex wrench	1

Pre-Assembly (continued)

PACKAGE CONTENTS

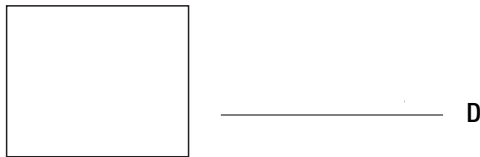
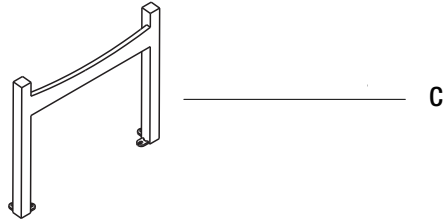
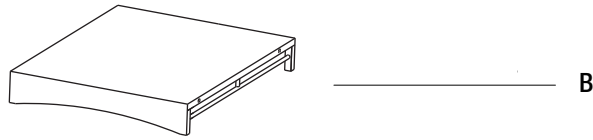
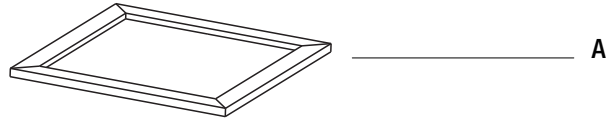

Part	Description	Quantity
A	Table rim	1
B	Apron	1
C	Table leg	2
D	Glass	1

Assembly

1 Attaching the table legs

- Place the glass top (D) aside from the table rim (A).
- Place the table rim (A) upside down on a flat, smooth surface.
- Attach the table legs (C) to the table rim (A) with washers (CC) and bolts (AA), using the hex wrench (EE).

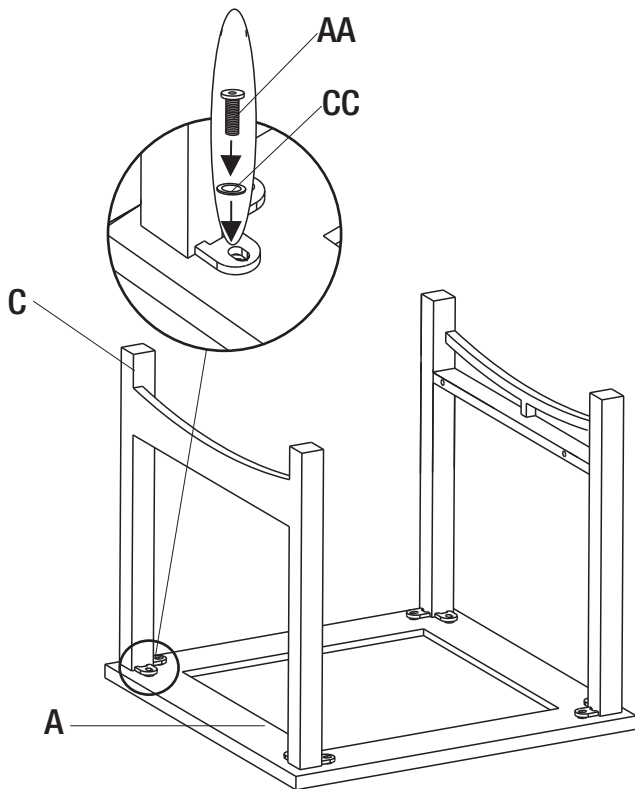

2 Attaching the apron

- Align the apron (B) among two table legs (C).
- Secure the apron (B) to table legs with washers (CC) and bolts (BB) using hex wrench (EE).
- Fully tighten all bolts (AA, BB) and cover them with bolt caps (DD).

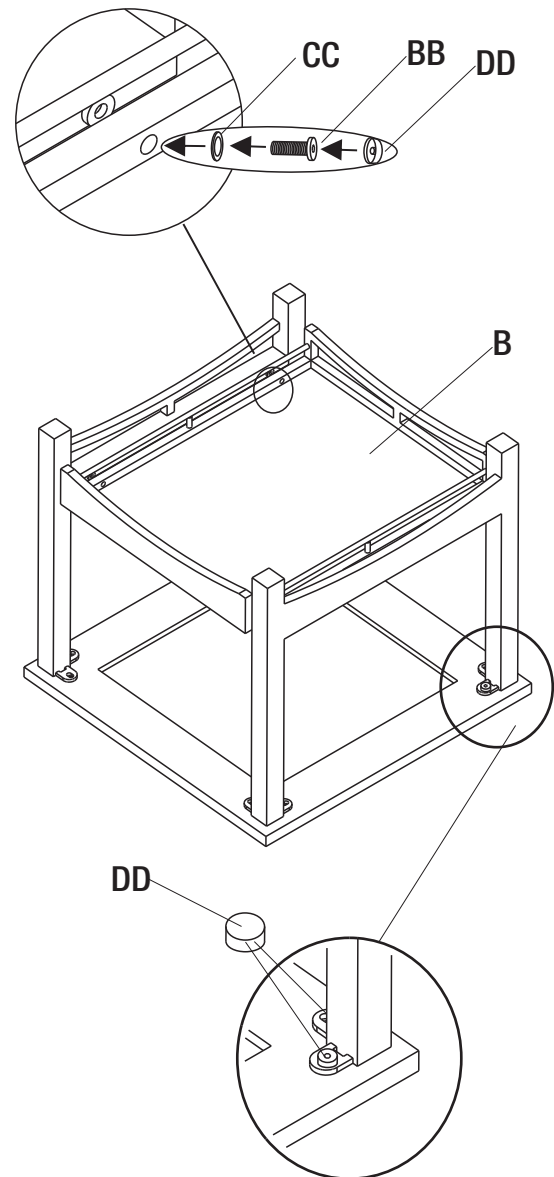

Assembly (continued)

3 Attching the glass top

- Turn over the table frame to upright position.
- Inset the glass (D) into the table rim (A).

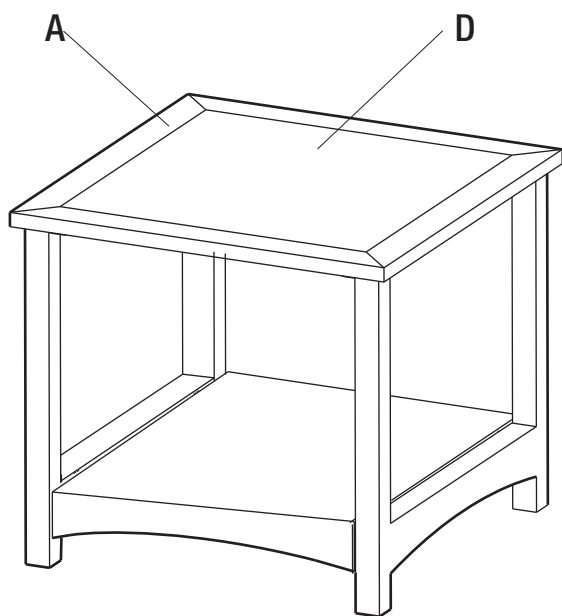



Questions, problems, missing parts? Before returning to the store,
call Hampton Bay Customer Service
8.00 a.m. – 6.00 p.m., EST, Monday-Friday

1-855-HD-HAMPTON

HAMPTONBAY.COM

Retain this manual for future use.