

HOME DECORATORS COLLECTION

SK17030 SHUTTER SHOE STORAGE 36"Hx35"Wx14"D

INV#11580

ASSEMBLY INSTRUCTIONS

Made In China

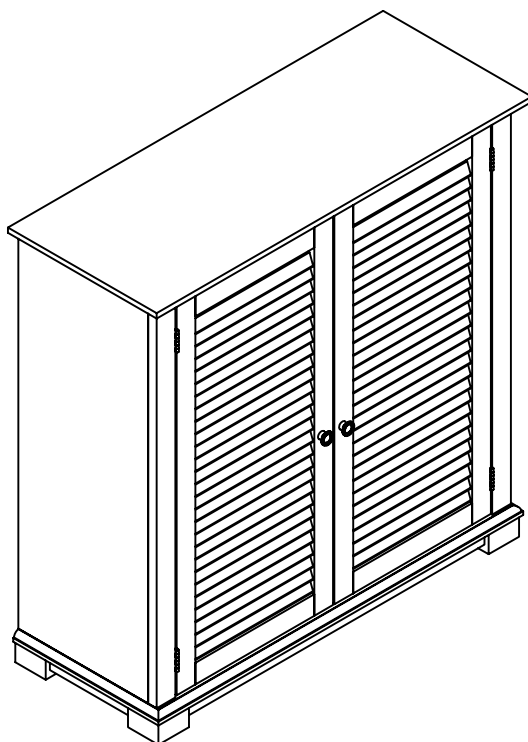

Thank you for purchasing this quality product. Be sure to check all packing material carefully for small parts, which may have come loose inside the carton during shipment. Count all parts and material hardware, then compare with parts list to be sure all parts are present. If any parts are missing or damaged, phone, fax, or mail to our Customer Service Department for efficient and speedy service. Please indicate the model number and code letter of part(s) needed.

IMPORTANT NOTE: Follow instructions listed below in proper sequence as numbered to assure fast, easy and correct assembly.

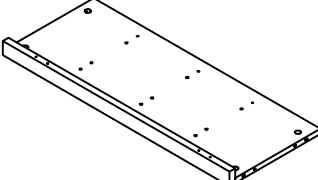
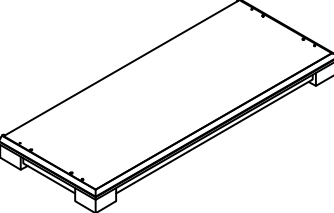
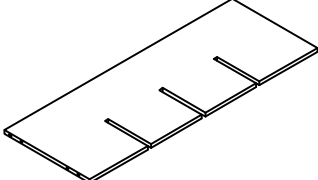
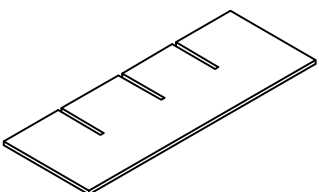
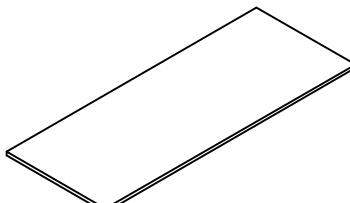
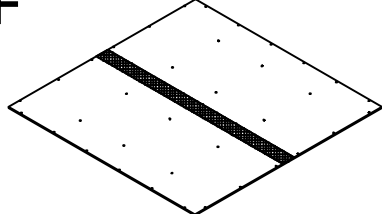
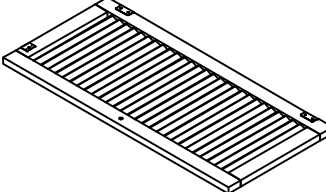
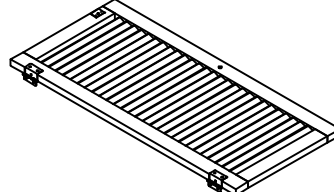
PARTS LIST		
A 	B 	C 
SIDE PANEL-2PCS	BOTTOM PANEL-1PC	FIXED SHELF-3PCS
D 	E 	F 
DIVIDER-3PCS	TOP PANEL-1PC	BACK PANEL-1PC
G 	H 	
LEFT DOOR-1PC	RIGHT DOOR-1PC	

a



WOOD DOWEL-20PCS

b

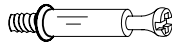

CAM LOCK BOLT-20PCS

c



CAM LOCK-20PCS

d



ROUND HEAD SCREW-40PCS

e



PLASTIC COVER-8PCS

f



KNOB-2PCS

g



KNOB BOLT-2PCS

i



MAGNET-2PCS

j



FLAT HEAD SCREW-8PCS

NOTE:THE SURFACE WITH THE STICKER IS THE BACK SIDE

NOTE: • UPON OPENING, THOROUGHLY CLEAN ALL WOOD SURFACES TO REMOVE DUST AND DIRT THAT MAY HAVE SETTLED ONTO THE FINISH DURING SHIPMENT. IN ORDER TO PREVENT DAMAGE DURING ASSEMBLY. PLEASE ASSEMBLE THIS ITEM WITH AT LEAST TWO PEOPLE.

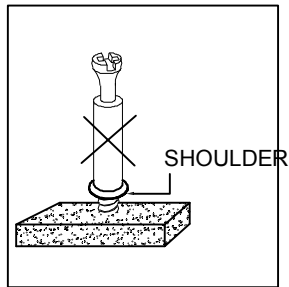
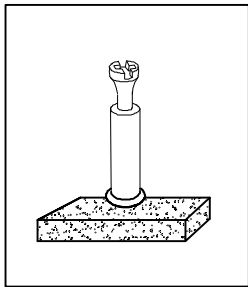

NOTE: TURN THE CAM-BOLT SCREWS UNTIL THEY ARE TIGHT, THE SHOULDER SHOULD BE AGAINST THE SURFACE OF THE PART.

HOW TO USE THE CAM-TOOL

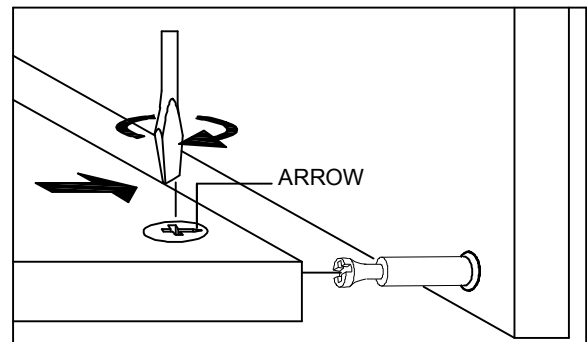
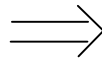
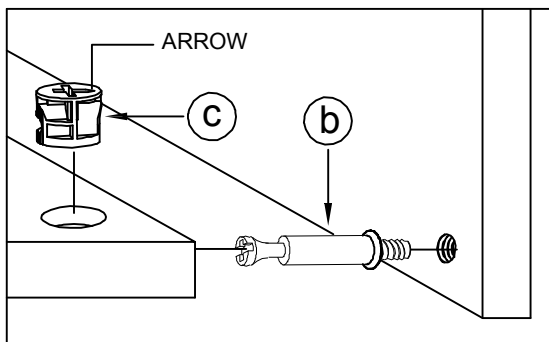

NOTE: • THE ARROWS ON THE HIDDEN CAM-LOCKS SHOULD POINT TO THE CAM-BOLTS.

FIG 1

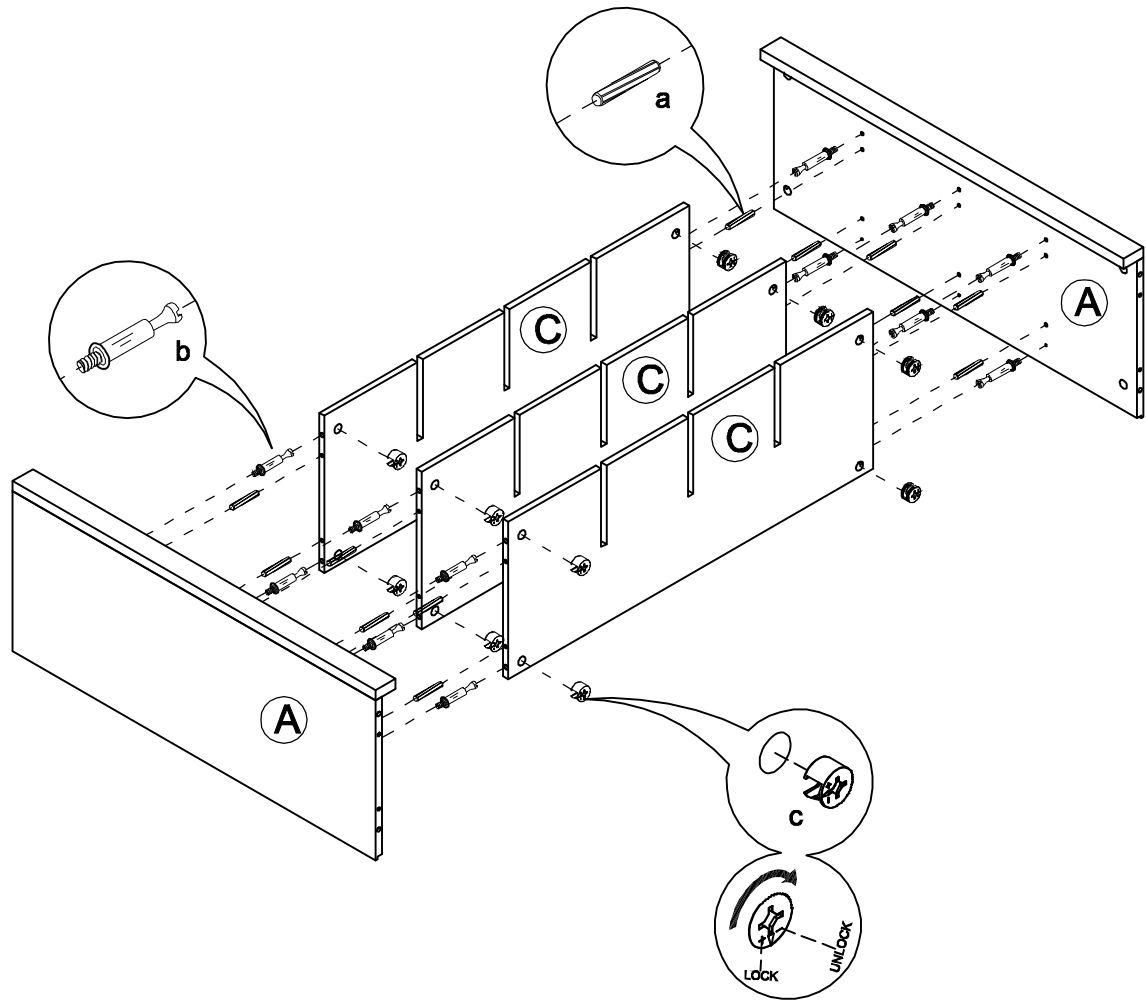

- INSTALL THE WOOD DOWEL (a) AND THE CAM LOCK BOLT (b) INTO THE SIDE PANEL (A).
- JOIN THE SIDE PANEL (A) TO THE FIXED SHELF (C) BY USING THE WOOD DOWEL (a) FIRST.
- ONCE JOINED, TIGHTEN CAM LOCK (c) ONTO BOLT (b) USING PRE-DRILLED HOLES.

FIG 2

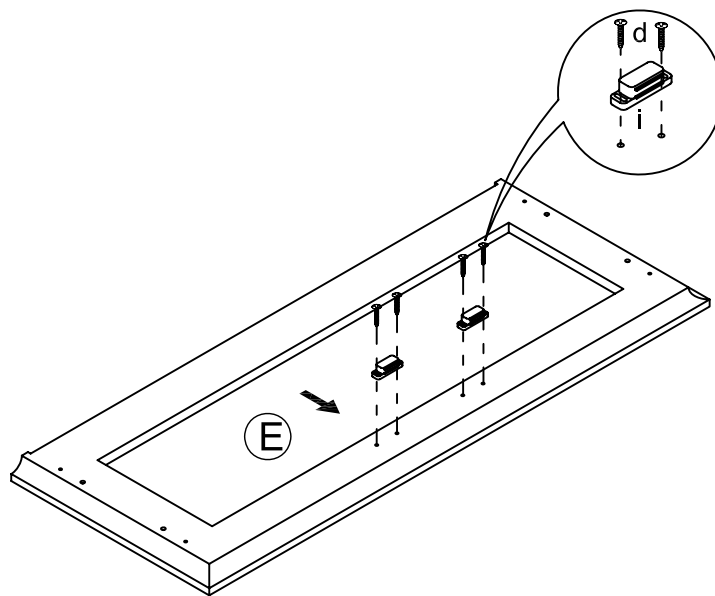

- TIGHTEN THE MAGNET (i) TO THE TOP PANEL (E) BY USING THE ROUND HEAD SCREW (d).

FIG 3

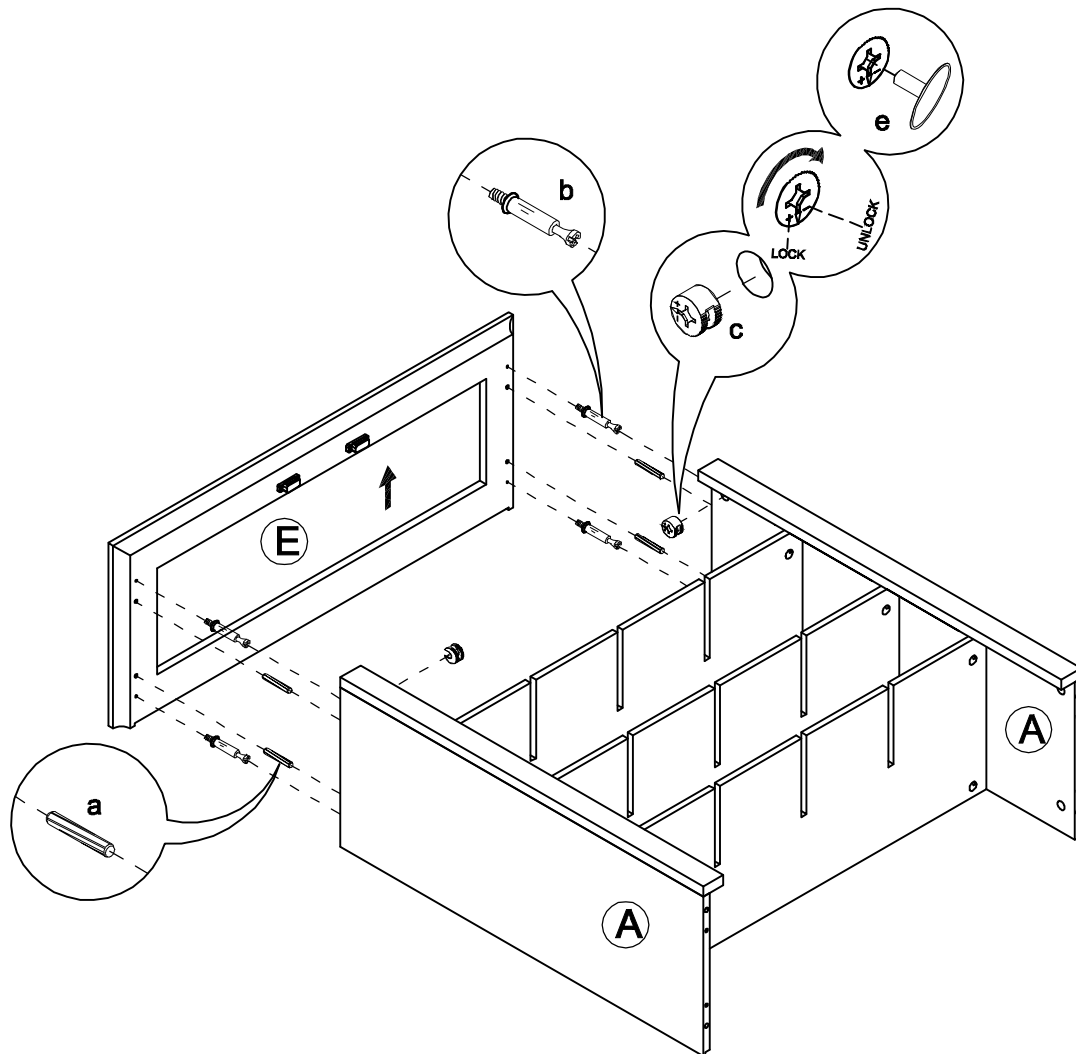

- INSTALL THE WOOD DOWEL (a) AND THE CAM LOCK BOLT (b) INTO THE TOP PANEL (E).
- JOIN THE TOP PANEL (E) TO THE ASSEMBLED PART BY USING THE WOOD DOWEL (a) FIRST.
- ONCE JOINED, TIGHTEN CAM LOCK (c) ONTO BOLT (b) USING PRE-DRILLED HOLES.
- COVER CAM HOLES WITH THE PLASTIC COVER (e).

FIG 4

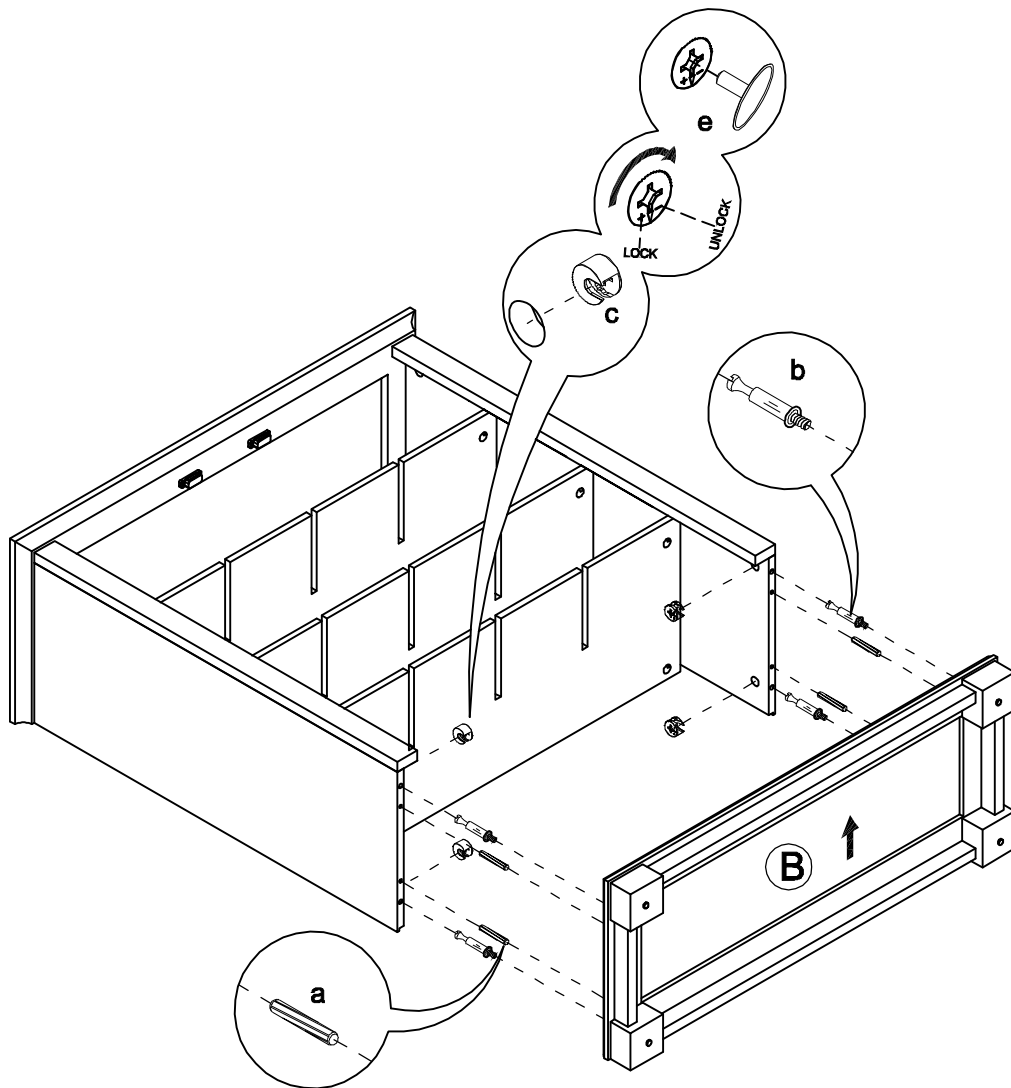

- INSTALL THE WOOD DOWEL (a) AND THE CAM LOCK BOLT (b) INTO THE BOTTOM PANEL (B).
- JOIN THE BOTTOM PANEL (B) TO THE ASSEMBLED PART BY USING THE WOOD DOWEL (a) FIRST.
- ONCE JOINED, TIGHTEN CAM LOCK (c) ONTO BOLT (b) USING PRE-DRILLED HOLES.
- COVER CAM HOLES WITH THE PLASTIC COVER (e).

FIG 5

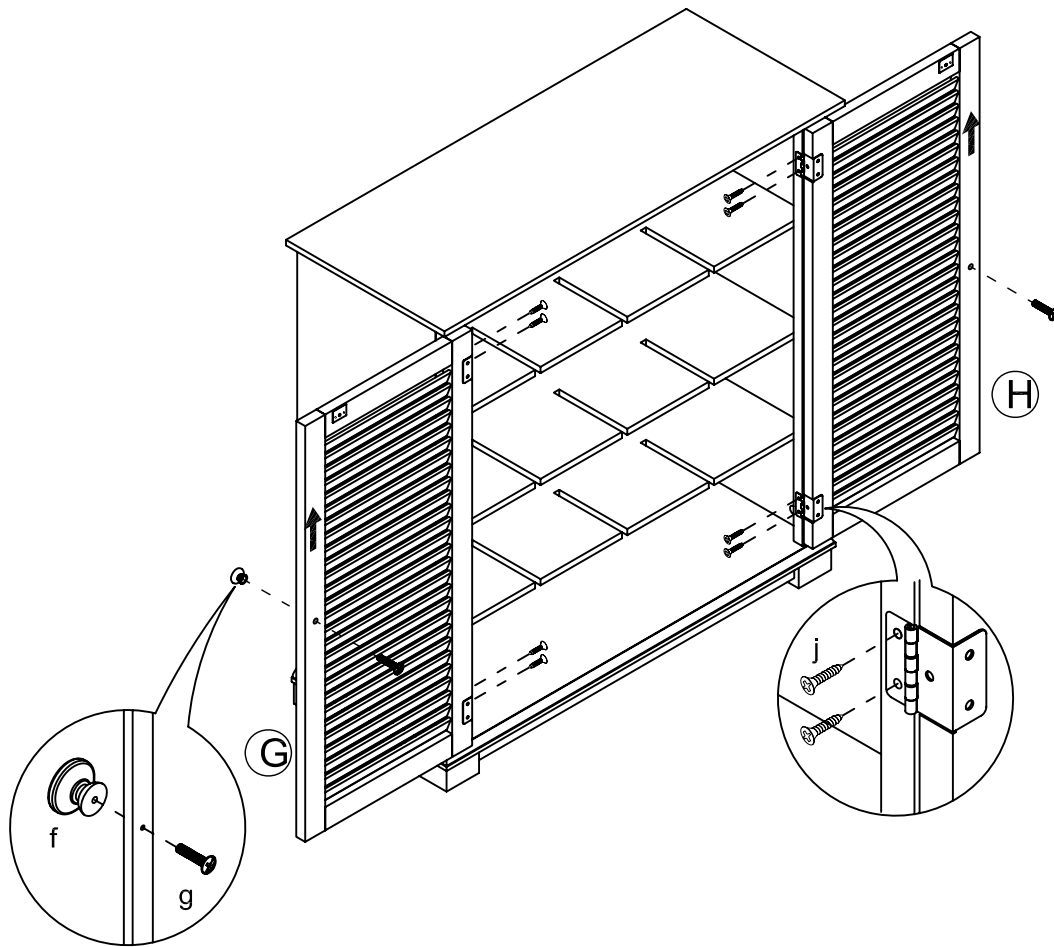

- ATTACH THE LEFT DOOR (G) AND THE RIGHT DOOR (H) TO THE ASSEMBLED PART BY USING THE FLAT HEAD SCREW (j).
- TIGHTEN THE KNOB (f) BY ONTO THE LEFT SIDE DOOR (G) AND THE RIGHT SIDE DOOR (H) BY USING THE KNOB BOLT (g).

FIG 6

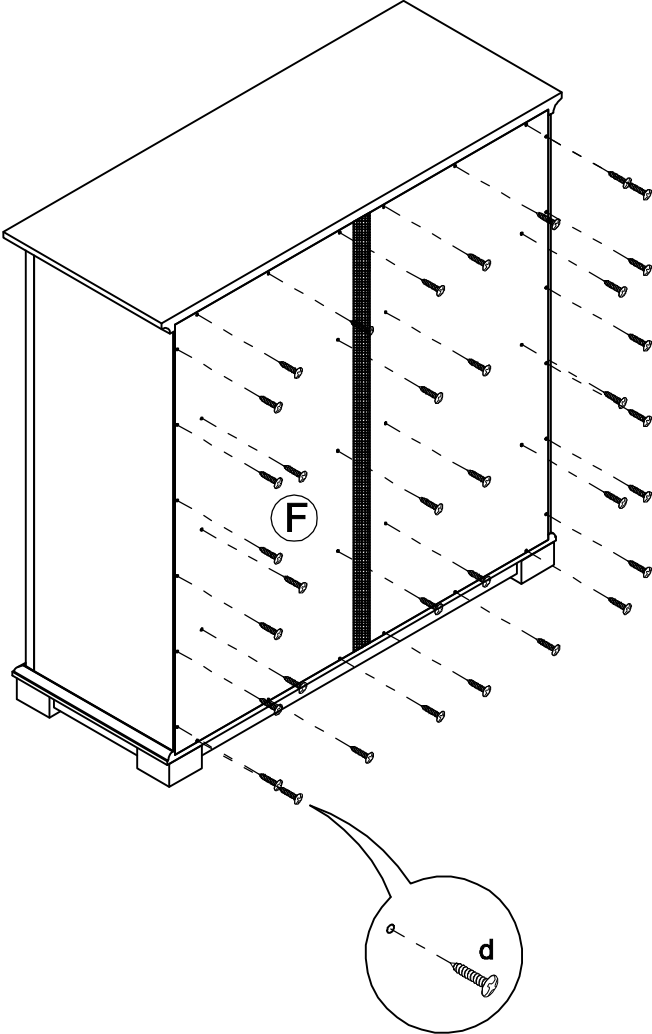

● TIGHTEN THE BACK PANEL (F) TO THE ASSEMBLED PART BY USING THE ROUND HEAD SCREW (d).

FIG 7

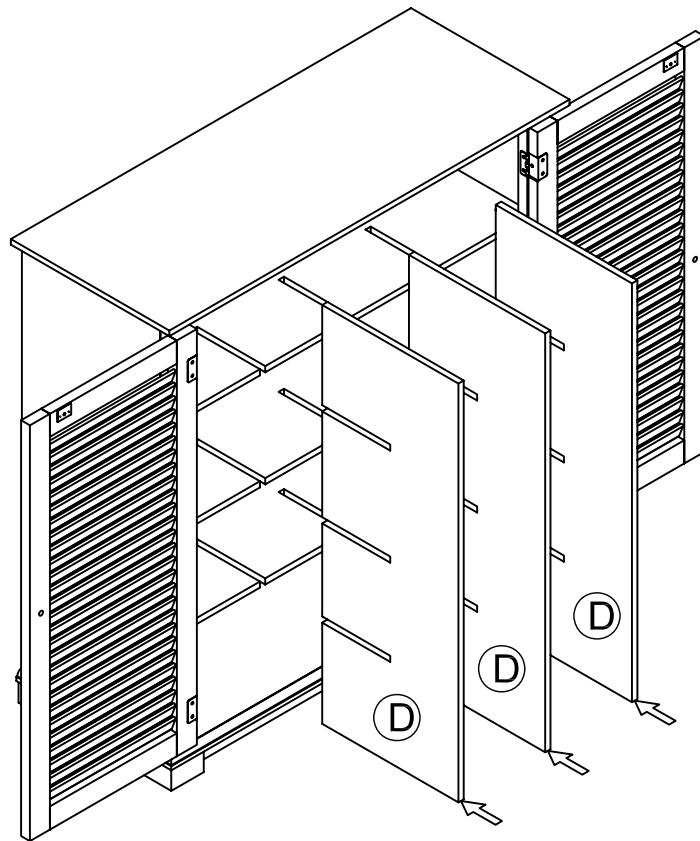

- SLIDE THE DIVIDER (D) VERTICALLY TO THE PROPER POSITION AGAINST THE FIXED SHELF (C).