

SINGULAIR® BIO-KINETIC®

WASTEWATER TREATMENT SYSTEM

Dear Owner:

When you purchased your Norweco Singulair Bio-Kinetic wastewater treatment system, a three year limited warranty and lifetime exchange program were included in the purchase price. The purchase price also provided for a two year service inspection program at no additional cost to you.

We are pleased to be able to offer a continuing service program similar to the one originally included with your system, now that your initial service program and limited warranty have expired. Our continuing policy ranges all the way from routine inspections and emergency service to owner limitation on labor costs. We have enclosed a complete copy of our renewable service contract, with costs for your system, for your review and consideration.

We would be happy to answer any questions regarding the renewable service program or any other questions you may have regarding operation and maintenance of your Singulair wastewater treatment system. Please take the time to review and consider the advantages of the service contract we have enclosed. As in the past, our company also continues to offer service and repair for systems on an "as needed" basis in the area we serve. Thank you.

Sincerely yours,

Your Local Licensed Norweco Distributor

NORWECO, INC. - NORWALK, OHIO - U.S.A.

SINGULAIR®

OWNER PROTECTION SERVICE PROGRAM

AT NO ADDITIONAL
OWNER EXPENSE

POSSIBLE
EXPENSE

A. Regular service inspections conducted at six month intervals throughout the year.

B. Special service inspections as requested by owner.

C. Labor and transportation expenses for travel on regular service inspections.

D. Labor and transportation expenses for travel on special service inspections.

E. Singulair plant maintenance including Bio-Kinetic system service, visual inspection of effluent quality and cleaning of hopper section using squeegee scraper in clarification tank (where applicable).

F. Inspection of outlet line or disposal system (where accessible).

G. Singulair mechanical aerator maintenance including cleaning of the stainless steel aspirator shaft, power consumption check, noise check, and visual inspection for vibration of the unit while in operation.

H. Visual check of Service Pro control center for Singulair unit (when accessible).

I. Labor expenses required at the site to service or repair, or to remove any part of the control center or Singulair mechanical aerator to be returned for factory repair.

J. Labor required at the site to service, repair or reinstall any part of the Service Pro control center or Singulair mechanical aerator returned from factory repair.

K. Service Pro remote monitoring service (where applicable).

L. Freight costs to and from the factory and lifetime exchange program costs when factory repairs are needed.

M. Costs for replacing missing parts or repairing equipment not eligible for the lifetime exchange program.

CONTRACT FEE \$ _____

(To Be Paid In Advance By Owner)

OWNER ACCEPTANCE

NAME: _____

ADDRESS: _____

EMAIL: _____

DATE: _____

NORWECO SINGULAIR DISTRIBUTOR

NAME: _____

BY: _____

DATE: _____

COMPLETE AND RETURN TO YOUR LOCAL NORWECO DISTRIBUTOR



To:

Local Dist.

Place Stamp
Here
Post Office Will
Not Deliver
Without Proper
Postage

norweco® SINGULAIR® SERVICE CONTRACT

OWNER NAME: _____

ADDRESS: _____ EFFECTIVE DATE: _____ 20 _____
(street)

_____ EXPIRATION DATE: _____ 20 _____
(city) (state) (zip)

TELEPHONE NO.: (____) _____ SYSTEM INSTALLED ON: _____ 20 _____

DIRECTIONS: _____

This one year service contract for the Singulair Bio-Kinetic wastewater treatment system located at the site described above, is intended to enable the owner to economically obtain regular service inspections for the Singulair unit, as well as non-scheduled or special service that may be required by a qualified technician. When this contract is in force, the owner will not be charged for any routine service labor. Under the terms of this service agreement, a technician will regularly inspect the plant at six month intervals. It will also be inspected following each special owner service request within a 48-hour period. If improper system operation cannot be remedied at time of inspection, the owner will be notified in writing of an estimated date of correction. The contract shall remain in effect for a period of one year, as specified in the effective and expiration dates listed above.

norweco® SERVICE PRO®

CONTROL CENTER WITH MCD TECHNOLOGY

TIME CLOCK SETTING AND SERVICE INSTRUCTIONS

The design of the Singulair system incorporates 48 hour retention and non-mechanical flow equalization to provide continuous treatment. The performance of the Singulair system has been tested and certified with the aerator operating on a minimum run cycle of 30 minutes per hour and no adjustment should be made to the factory preset time clock setting without following the detailed steps outlined in these instructions.

INTRODUCTION

The biological processes in the aeration chamber of the Singulair system convert wastewater to microorganisms, carbon dioxide and water. The Singulair system is designed so that the aerator will operate 30 minutes out of each hour. Under typical organic loading conditions, this run cycle will maintain a balance between organic loading and the level of microorganisms in the aeration chamber. If an increase in organic loading occurs, increasing the aerator run time will result in additional aerobic digestion and allow the biological balance to be maintained. Prior to adjusting the aerator run cycle, a complete Singulair system service inspection, including pretreatment chamber evaluation, aerator service and measurement of air delivery must be performed. Whenever the pretreatment chamber is pumped, the system should be given time to achieve a biological balance before considering time cycle adjustment. Adjustments to the aerator run cycle should not be made within one week of any other system process changes, including system pump out or extended vacation.

NITRIFICATION AND DENITRIFICATION

Nitrification is the oxidation of nitrogen compounds (primarily ammonia) that results in the production of nitrates. This process improves the quality of the effluent returned to the environment and is an important step in wastewater treatment. Nitrification is routinely performed by the Singulair system and the level of performance is directly linked to biological balance within the system.

Denitrification will only occur if nitrification has already taken place. Denitrification is the process of breaking down nitrates into oxygen and nitrogen. The Bio-Static sludge return prevents denitrification (sludge bulking) in the clarification chamber by continuously returning solids to the aeration chamber. Denitrification will occur in the aeration chamber if the aerator time cycle is properly adjusted. To accomplish denitrification, the aerator off cycle must be long enough to allow the aerobic bacteria to consume the available dissolved oxygen and the nitrate bound oxygen, thereby returning the nitrogen to its natural state. It is important that the aerator have a long enough off cycle to deplete dissolved oxygen levels in the aeration chamber in order to achieve partial or total denitrification.

SETTLABLE SOLIDS TEST

To determine if an adjustment to the aerator run cycle is required, a Settleable Solids Test must be conducted. See Singulair Tank Pumping Instructions for details on performing this test. Too much air being introduced to the system (overaeration) will negatively affect operating characteristics. This condition is indicated by finely divided particles and/or crisp, white foam floating in the Settleable Solids Test or aeration chamber. The supernatant will be turbid (cloudy) with fine suspended particles (pin floc). Solids will be lighter brown, almost white, in color. Overaeration will not allow proper settling of the treated wastewater and may adversely affect system performance. Likewise, too little air being introduced to the system (underaeration) will cause the system to operate at less than its maximum efficiency. Underaeration is indicated by darker and more coarse solids in the Settleable Solids Test or aeration chamber and may have a dark, thick foam or scum layer

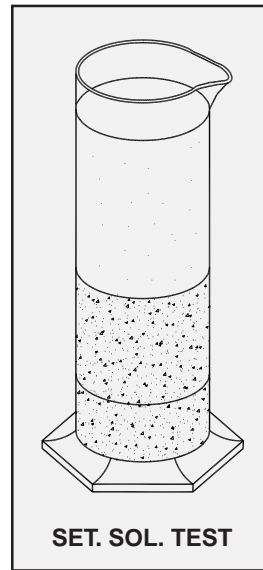

on the top. This condition is similar in appearance to organic overloading and the system may have a foul or septic odor. The supernatant will have a grey, almost dishwater, appearance. Solids will have a grainy appearance and will settle more compactly due to their thickness and greater density.

To check for nitrification during the Settleable Solids Test, allow the sample to sit undisturbed for 2 to 3 hours. The nitrogen (fine bubbles) being released should cause all or a portion of the solids to float to the top. This process is called sludge bulking and is actually denitrification occurring in the sample container. The solids may then break up and settle to the bottom of the sample. For Singulair systems with more than one aerator, the Settleable Solids Test should be conducted on a sample from each aeration chamber. The results of all tests should be averaged to evaluate system operation.

TIME CLOCK SETTING AND SERVICE INSTRUCTIONS (Cont.)

The results of the Settleable Solids Test should be evaluated using the following chart:

Settleable Solids Test Result			Condition Indicated	Adjustment Required
Color of Solids and Liquids	Settled Solids Volume	Additional Observations		
Very light brown solids with gray cloudy liquid.	Less than 25%.	Some surface foam. Poor separation and settling of solids.	Hydraulic overloading, organic underloading, or system has not yet reached process maturity.	No adjustment until process maturity is reached. If mature and properly loaded, decrease aerator run time. DO NOT decrease run time to less than 30 minutes per hour.
Light to medium chocolate brown solids with clear liquid.	25% to 50%.	No foam.	Proper operation.	None.
Medium to dark chocolate brown solids with clear liquid.	50% to 75%.	No foam.	Proper operation.	None.
Very dark brown solids with cloudy brown liquid.	Greater than 75%.	Dense sludge with rapid settling.	Organic overloading.	Evaluate pretreatment chamber. Increase aerator run time if required.
Black solids with gray liquid.	In any volume.	Foul odor and finely divided particles.	Toxic material in influent.	Evaluate system per Singulair Service Manual. Review Owner's Manual with owner.

DISSOLVED OXYGEN TEST

A dissolved oxygen (DO) test can be conducted on the aeration chamber contents to confirm overaeration or underaeration. The DO test can be performed on site using a properly calibrated portable DO meter with probe. The DO level can also be accurately determined through the use of an inexpensive colorimetric test performed on a properly filtered sample from the aeration chamber. DO in the aeration chamber typically ranges from 0.5 mg/L to 9.5 mg/L and fluctuates according to cycle time and other factors including temperature and solids level. Comparison samples must be taken at the same point during the aerator run cycle because DO levels will vary according to cycle time. DO levels in the aeration chamber must be greater than 2.0 mg/L at the end of the aerator run cycle to accomplish nitrification and less than 0.5 mg/L at the end of the aerator off cycle to accomplish denitrification. A properly balanced system will have more than sufficient air during the run cycle to allow nitrification to take place and will deplete DO during the off cycle sufficiently to allow partial or complete denitrification.

Some areas have specific DO requirements for effluent returned to the environment and the same tests can be conducted on final effluent samples. The treatment processes of the Singulair system will cause effluent DO to differ from aeration chamber DO levels. Typical effluent DO will range from 1.0 mg/L to 6.0 mg/L depending on location, temperature and time of year.

HYDRAULIC OVERLOADING

Hydraulic overloading of the Singulair system is an indication that too much liquid is coming into the plant. This situation can adversely affect biological treatment and should be corrected immediately. Leak testing should be performed on toilets, faucets and other fixtures that discharge into the domestic wastewater plumbing to be sure that they shut off completely when not in use. Confirm that roofing down spouts, sump pump piping and other improper connections are not discharging into the Singulair system. Crushed or leaking influent sewer lines can cause groundwater to enter the system and should be thoroughly checked by a qualified contractor.

ORGANIC OVERLOADING

The Singulair system is designed to handle typical domestic waste. Occasionally, a specific application may result in excessive organic loading to the system. If you encounter an organic overload, the aerator run cycle can be adjusted in five minute increments up to continuous run. Instruct the owner regarding proper use of the system as described in the Singulair Owner's Manual.

MANUFACTURED BY

norweco[®]

Engineering the future of water
and wastewater treatment

**NORWECO, INC.
NORWALK, OHIO
U.S.A. 44857**

www.norweco.com

SERVICE PRO®

CONTROL CENTER WITH MCD TECHNOLOGY

TIME CLOCK SETTING AND SERVICE INSTRUCTIONS (Cont.)

HIGH ALTITUDE INSTALLATIONS

The Singlair aerator delivers more than 150% of the air required by nationally recognized wastewater treatment design standards. This abundant supply of air allows the Singlair system to be installed at high elevations without special consideration. At an elevation of 6,500 feet above sea level, the available oxygen is approximately 23% less than at sea level. In high altitude installations, adjustment to the aerator run cycle should be made based on the same evaluation procedures used for all Singlair systems.

INTERMITTENT USAGE

When the Singlair system is to be used intermittently (one day per week or a few days per month), the aerator run cycle should be adjusted to the minimum setting. When low usage or non-use periods are expected, precautions should be taken to insure the protection of system components. If an extended period of non-use (four months) is anticipated, the distributor should suggest complete system shut down and removal of components. This may only be done with the full knowledge and approval of the local regulatory agency. The final decision to shut down the system rests with the owner. The decision should be based on the same criteria as other seasonal or non-occupancy arrangements, such as care of hot water tanks, water pipes, refrigerators or freezers. The owner should arrange for the local distributor to remove and store the aerator and chemical feed tube(s) after vacancy. The service technician should place the control center selector switch in the "off" position. Arrangements must be made for the distributor to re-install Singlair system components before the site is to be re-occupied. Normal installation procedures, as outlined in the Singlair Service Manual, should be followed by the distributor when re-starting a system.

COMPLIANCE WITH REGULATIONS

Local regulatory officials must be informed whenever a time cycle adjustment is made. Regulatory agencies should participate in the adjustment decision and standard procedures should include consultation with regulators before any adjustment is made. Norweco distributors and service personnel should attempt to build and maintain a close relationship with regulatory officials. Consulting with regulators and owners before adjusting a Singlair time clock should strengthen communication and keep all parties properly informed. In instances where a close working relationship already exists with local regulatory officials, regulators may allow service personnel to submit notification after an adjustment has been made. Such a practice should only occur when a strong relationship exists between distributor and regulator and with the full knowledge and approval of the regulatory agency.

PRIOR TO SYSTEM ADJUSTMENT

The Service Pro control center is designed and manufactured to provide an aerator run cycle of at least 30 minutes per hour. The aerator run cycle can be adjusted, but in no case can the aerator operate less than 30 minutes per hour.

Use the Singlair flowmeter to determine that the proper amount of air is being introduced into the system. If the

flowmeter confirms that the Singlair aerator is infusing the proper amount of air, proceed with the Settleable Solids test. Should the Settleable Solids or Dissolved Oxygen tests indicate that a time cycle increase is desirable, turn the Service Pro control center time clock dial to the "continuous" position. Allow the system to operate on "continuous" run for a few weeks until the service technician is available to check the system and speak with the owner. If the system has not returned to normal operation, the system is experiencing a problem other than with the time cycle and

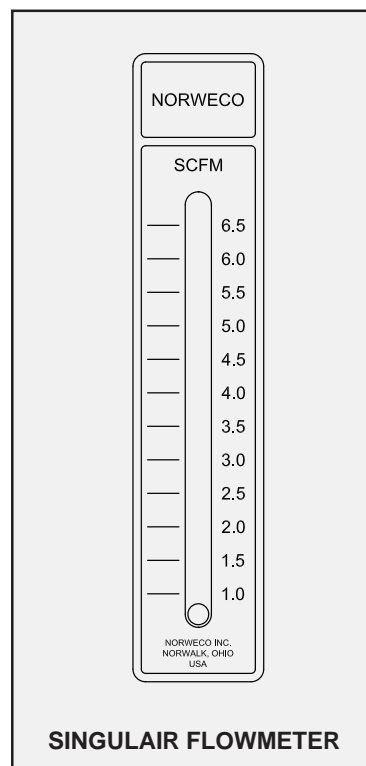

alternatives must be investigated. Refer to the "Hydraulic Overloading" and "Organic Overloading" sections of these instructions.

If the change to "continuous" run has solved the operational problem, the time clock should be adjusted to bring the system into biological balance. When the service technician returns to the site, and operation has returned to normal, the technician should adjust the time clock to reflect the deviation in loading from the original time clock setting. Adjust the aerator run cycle to half way between "continuous" run and the original time clock setting (e.g. if the original setting was 30 minutes, adjust the time cycle to 45 minutes out of each hour). Instruct the owner to monitor the system and notify you of any problems. After at least one month, when a service technician is available and in the geographic area, check the system again. Additional adjustments may be necessary to completely balance the system.

TIME CLOCK SETTING AND SERVICE INSTRUCTIONS (Cont.)

TIME CLOCK ADJUSTMENT

NOTE: Use a small blade screwdriver to rotate the time clock dial to the desired position. Do not use excessive force when turning the time clock dial.

Singulair systems with more than one aerator must have all control centers set for the aerators to operate on identical run cycles. Follow these steps to adjust the time clock:

1. Open the control center enclosure and place the selector switch in the "off" position.
2. Rotate the time clock dial clockwise until the arrow molded into in the dial is aligned with the desired run time setting.
3. Place the selector switch in the "on" position.

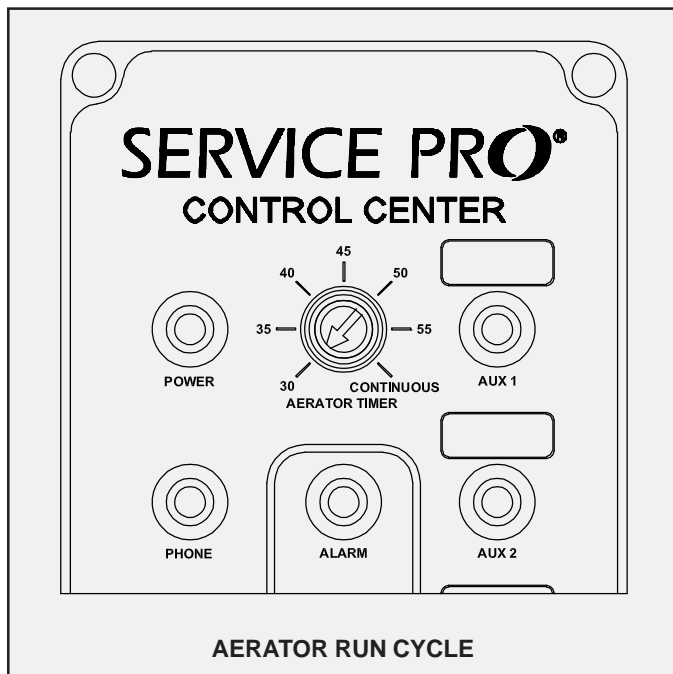

4. Close the control center cover and secure it with a tamper evident seal.
5. Record the new aerator run cycle on the Service Inspection Card.

SERVICE INSTRUCTIONS

The operation of the Service Pro control center can be verified on site through a series of tests. Before testing the Service Pro control center operation, insure the aerator is installed in the Singulair tank and the watertight electrical connector is plugged into the aerator power cord. To restart the aerator time clock cycle, place the selector switch in the control panel momentarily in the "off" position. Return the selector switch to the "on" position. The aerator should now be operating.

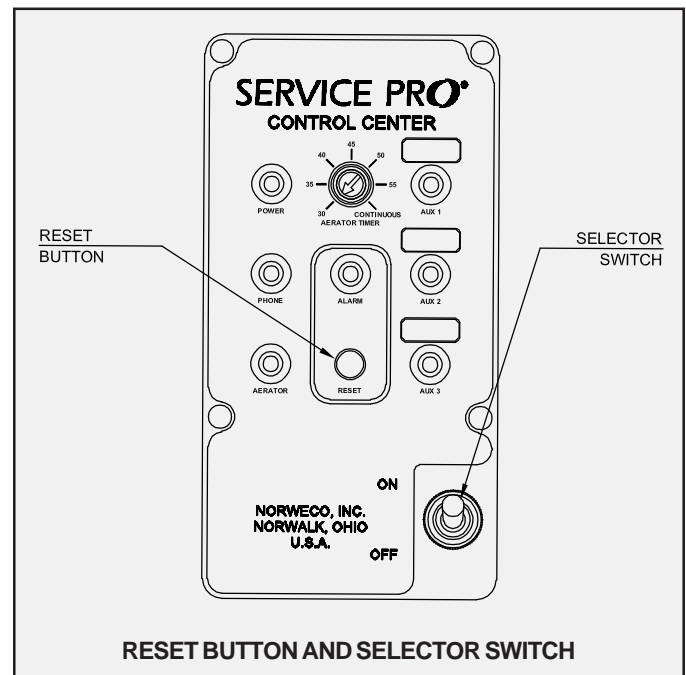

Allow the aerator to operate for 60 seconds before proceeding. If the aerator turns off or the alarms on the control center activate, an aerator over current condition has been detected or a problem has been detected in the Service Pro control center.

To test the aerator under current detection feature, simply unplug the watertight electrical connector from the aerator power cord. The visual alarm indicator on the control center should begin to flash within five seconds. Plug the electrical connector into the aerator power cord. The aerator should resume normal operation within five minutes and the visual alarm indicator on the control center will turn off.

To test the audible and visual alarms, hold the reset button in for five seconds. The alarms will activate for a five second period and then turn off.

Should the Service Pro control center require any service, replace the entire control center insert.

CAUTION: Be sure to shut off the Singulair circuit breaker in the main electrical service panel before any repairs are made. Confirm that the incoming electrical service reads zero volts before proceeding with control center insert replacement. Refer to Control Center Wiring and Installation Instructions for details on replacement of the control center insert.





SINGULAIR GREEN® BIO-KINETIC® WASTEWATER TREATMENT SYSTEM

SINGULAIR® AERATOR SERVICE

The Singulair aerator has been specifically designed for use in the Singulair Green system and is the only electro-mechanical component. It provides maximum air introduction, thorough mixing and assures reliable, economical wastewater treatment. The Singulair aerator is factory lubricated for the life of the unit. No service inside the aerator is required. Unauthorized disassembly will void the warranty. If a problem is suspected with the aerator, return it to Norweco for warranty replacement or exchange.

CAUTION: Any time an aerator or test equipment is connected or disconnected, first shut "off" the selector switch in the control center. Failure to do so could result in personal injury or equipment damage.

1. Open the control center and push the reset button on the Service Pro panel.
2. As you approach the Singulair Green tank, listen for excessive noise before removing the vented cover.
3. Remove the vented access cover located above the aeration chamber and place it aside. The aerator should be operating normally.
4. Make sure the debris screens are in place in the air intake ports. Manually check the aerator brackets for excessive vibration.
5. Check the aeration chamber for odor. A musty odor indicates the presence of aerobic conditions essential for good treatment. A septic odor indicates inadequate aeration, suggesting that the passage of air into the tank contents has been restricted.
6. Carefully remove the debris screens from the air intake ports. Wipe the aerator air intake ports with a damp cloth being careful not to allow dirt or debris to enter the intake openings.
7. Using the Singulair flowmeter, check the air delivery. It should read approximately 3 CFM. Refer to the Singulair Aerator Flowmeter instruction sheet for complete details.
8. Inspect the outside of the electrical connector assembly for worn spots. Uncouple the connector and check for any evidence of moisture inside. Secure the closure cap over the female half of the connector to keep it clean and dry while you work.
9. Within 2-3 minutes after turning off the aerator, perform a settleable solids test of the aeration chamber contents. Refer to Singulair Green Tank Pumping instructions for details.
10. Remove the aerator from the mounting riser. BE CAREFUL when removing the aerator to see that the aspirator shaft does not come in contact with the mounting riser. The aspirator shaft is straightened to a critical tolerance before it is shipped from the factory. It must retain this straightness tolerance or vibration may result. Excessive vibration can greatly shorten aerator life and could also cause the unit to consume more electrical power than necessary.
11. Check the rubber shock absorbers on each bracket for wear. Replace any that are missing or worn.
12. Check the power cord from the moisture resistant electrical connector to the aerator. Be sure it is free of nicks or worn spots.
13. Lay the aerator on its side against the aerator mounting riser or vented cover. Check to see if there is a water mark on the outside of the aerator and notify the owner if one is found. The aerator is flood proof and mechanically designed so that it can return to normal operation unharmed after being subjected to intermittent high water. However, a high water mark on the outside of the aerator does indicate there is a problem in the effluent disposal line, disposal field or elsewhere in the installation. If the problem is left uncorrected, wastewater could back up into the tank, void the aerator warranty and eventually flood the facility.

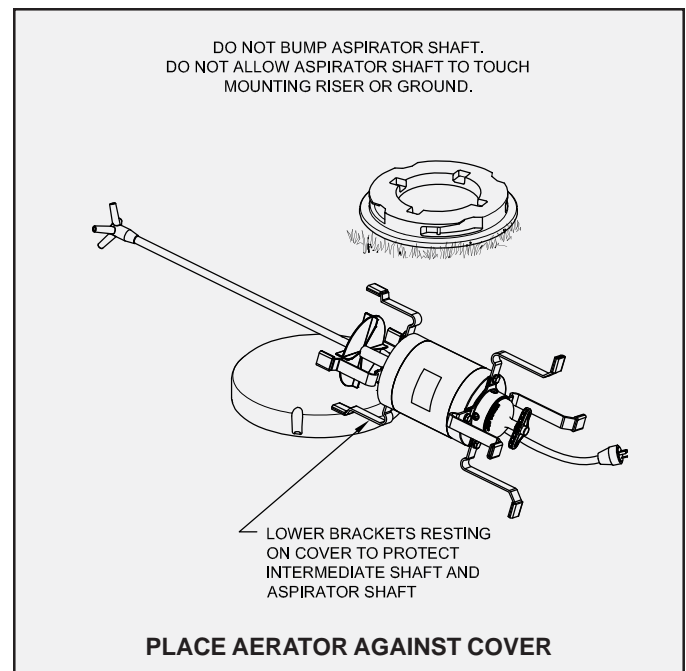

SINGULAIR® AERATOR SERVICE (Cont.)

14. Carefully loosen the two stainless steel set screws on the bottom of the intermediate shaft and remove the aspirator shaft. Remove any internal deposits from the four aspirator orifices with the aspirator shaft cleaning tool. Connect the aspirator shaft to the shaft cleaning hose and outside water faucet to flush the inside of the aspirator shaft clean. Use full water pressure. Remove the shaft from the cleaning hose and inspect the bore to see that it is clean.
15. Push the stainless steel brush with extension handle through the stainless steel intermediate shaft and hollow motor shaft to dislodge any residue that may have accumulated. **NOTE:** Do not flush the motor shaft with water. Remove any debris from the air intake openings.
16. Thoroughly clean both the bottom and the top surfaces of the foam restrictor.
17. Reinstall the aspirator shaft into the intermediate shaft. Match the permanent alignment marks on the aspirator and intermediate shafts to maintain the original factory balance. Tighten the set screws with a tee-handle allen wrench, finger tight only. Too much pressure may dish the side of the aspirator shaft and compromise the straightness tolerance.
18. Clean or replace the four air intake debris screens. Make sure one screen is placed in each intake opening to prevent debris from entering the aerator.
19. Visually check the aeration chamber surface for the presence of grease or oil. An accumulation of these materials indicates the pretreatment chamber should be evaluated. Refer to Singulair Green Tank Pumping instructions for details.
20. Check the aeration chamber for the presence of non-biodegradable materials, paper, mop fibers, hair, grease or oil. A significant accumulation of these materials in the aeration chamber indicates the pretreatment chamber should be evaluated. Refer to Singulair Green Tank Pumping instructions for details.
21. Inspect the underground power cable in the aerator mounting riser for breaks or scars in the insulation. Examine the inside of the mounting riser for evidence of ground water entry.
22. Carefully reinstall the aerator in the mounting riser. Do not allow the aspirator shaft to touch the mounting riser side walls. Make sure the weight of the aerator is evenly distributed on the upper end of all four mounting brackets.
23. Using a multi-meter, check the voltage at the electrical connector. The meter should read 115 volts \pm 5% when the selector switch in the Service Pro control center has been placed in the "on" position. Record the voltage on the Service Inspection Card.
24. Wipe the aerator electrical connector with a clean, dry cloth to remove moisture or dirt accumulated during service. Plug the electrical test pigtail in between the male and female electrical connectors and check the amperage of the newly serviced aerator. The aerator should not draw more than 4.2 amps. Record the amperage on the Service Inspection Card. **NOTE:** When the aerator is started for the first time, the break-in period may cause the amp draw to be as high as 4.4 amps for the first 48 hours of operation.
25. Inspect the perimeter vent area in the aerator access cover and clear the fresh air openings of any debris to insure unrestricted passage of air. Reinstall the access cover on the mounting riser.
26. Make the appropriate notations regarding the aerator, the results of the settleable solids test and related items on the Service Inspection Card.
27. Proceed with clarification chamber service as outlined in the Clarification Chamber and Bio-Kinetic Service instructions. When the routine service is complete, return to the Service Pro control center and confirm that the selector switch has been returned to the "on" position. Close the control center cover and secure it with a new tamper evident seal.

IF AN AERATOR MUST BE REMOVED

The service technician should be able to restore most installations to full operation during the initial service call. If the aerator is no longer eligible for the three-year limited warranty, the aerator should be removed and replaced with a remanufactured and fully warranted exchange unit from your rotating stock. This will become the permanent aerator in service at the facility and your company's service records should be updated to reflect the new aerator serial number. If the serial number portion of the Warranty Registration Card is still attached to the control center, be sure to fill in the new serial number for the owner. When you have accumulated several aerators requiring factory service, return them to Norweco. This reduces administrative time and the cost of shipment per unit. When remanufactured aerators are returned to you, add them to your rotating stock. In this way, the installation is restored to full service with a fully warranted unit in only one service trip.

EXCHANGE AERATOR COSTS

You may compute exact costs for exchange aerators during your service inspection since the cost is determined by system age, regardless of condition. Exchange rates are given on the Singulair Warranty and Exchange Program data sheet. In cases where the aerator has failed under warranty, you should replace it with a loaner unit to insure continued operation of the system and protect effluent quality. Return the warranted unit to the factory immediately for replacement and schedule reinstallation with the owner at the earliest possible convenience when it is returned to you.

MANUFACTURED BY

norweco®

Engineering the future of water
and wastewater treatment

**NORWECO, INC.
NORWALK, OHIO
U.S.A. 44857**

www.norweco.com



SINGULAIR GREEN® BIO-KINETIC® WASTEWATER TREATMENT SYSTEM CLARIFICATION CHAMBER AND BIO-KINETIC® SERVICE

Check operation of the Service Pro control center and complete all Singulair Aerator Service instructions to the point of aerator reinstallation before proceeding with clarification chamber service. Do not reinstall the aerator in the mounting riser until the Bio-Kinetic system has been removed from the Singulair Green tank. The aerator must be reinstalled prior to cleaning the clarifier walls to insure the return of settled solids to the aeration chamber by hydraulic currents flowing through the sludge return.

CAUTION: Anytime an aerator or service pump is connected or disconnected, first shut off the selector switch in the control center. Failure to do so could result in personal injury or equipment damage.

1. Move the Singulair field service cart with exchange Bio-Kinetic system and Tool Kaddy near the clarification chamber access cover. Remove the service container from the field service cart, unscrew the wing nuts holding the service container cover and set them aside. Remove the service container cover and place it upside down along side the clarification chamber access riser. Remove the exchange Bio-Kinetic system from the service container and set it aside. Remove the universal tool from the front of the Tool Kaddy and open the doors.

Bio-Kinetic system and the liquids in the tank for color and odor. Note the condition of the system on the Service Inspection Card.

NOTE: Attached to the Bio-Kinetic system service cover is a red tag listing the Singulair Green system model number, classification and daily treatment capacity. This service cover and tag must remain with the installation and be reinstalled after exchanging the Bio-Kinetic system.

CAUTION: Chemicals or liquids from the Bio-Kinetic system feed tubes should not be allowed to contact skin or clothing. Refer to the Blue Crystal and Bio-Neutralizer handling instructions and container labels for safety procedures and first aid. Liquids or chemicals from the feed tubes may cause grass or landscaping to discolor.

3. To prevent loss of liquid from the Singulair Green system during service, use the Bio-Kinetic system outlet sealing tool. Thoroughly lubricate both sides of the tool below the tabs to the rounded end with Bio-Kinetic lubricant. With the tabs facing toward the Bio-Kinetic system, insert the tool in between the Bio-Kinetic outlet flange and the receiving flange of the tank. Completely insert the tool to the bottom of the outlet coupling.
4. Using the disassembly tool, remove the internal components from the Bio-Kinetic system. The internal components should be set aside while the remainder of the Bio-Kinetic system is removed.
5. The Bio-Kinetic system is equipped with a drain valve and a fill valve to allow for easy removal and reinstallation during service. The locking lugs must be disengaged to allow for removal. Using the locking lug tool, rotate each of the four round black locking lugs clockwise from the locking slots in the access riser. Insert the universal tool lifting handle into the upper lip of the Bio-Kinetic system outer chamber bucket.

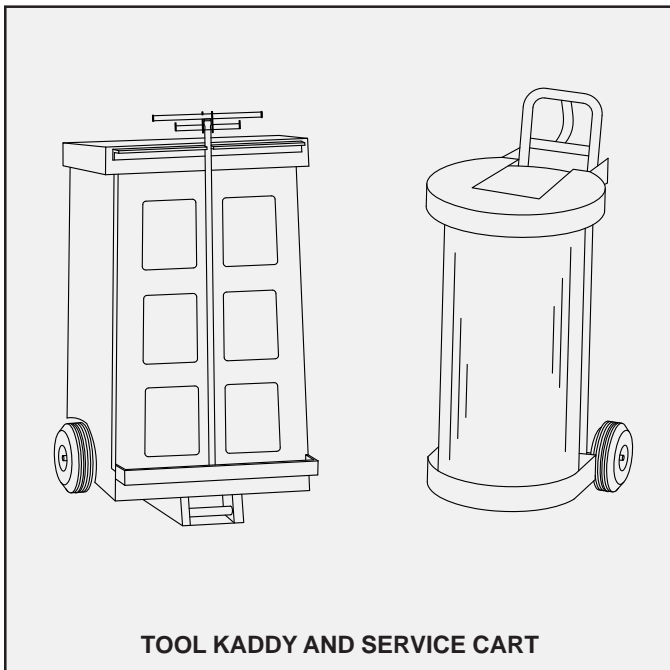

TOOL KADDY AND SERVICE CART

2. Remove the polypropylene clarification chamber access cover and turn it upside down near the access riser. If the unit is equipped with Blue Crystal or Bio-Neutralizer feed tubes, carefully remove each feed tube, one tube at a time. Lay each feed tube down on the access cover. Remove the Bio-Kinetic system service cover and check the condition of the

CLARIFICATION AND BIO-KINETIC® SERVICE (Page 2 of 6)

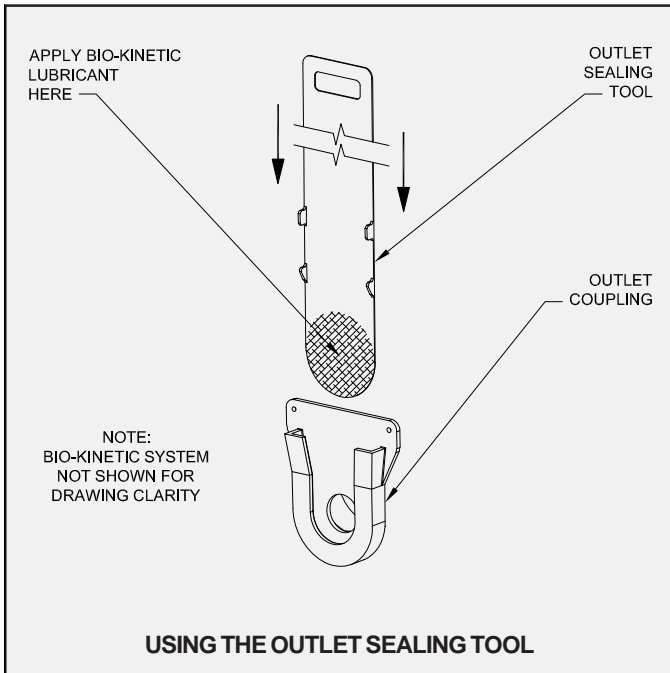

6. While standing over the riser, begin lifting the system from the tank. The self drain valve will automatically open as the system is lifted out of the riser. Continue lifting until the majority of the water has drained out of the system. Remove the Bio-Kinetic system from the mounting riser. Set the Bio-Kinetic system on the upside down lid of the service container
7. Record the color and condition of the Bio-Kinetic system on the Service Inspection Card and on the "Supplementary Service" section of the Owner's Manual. Make appropriate notations on the condition of the clarification chamber. Also note the liquid level on the filter media. The peak flow filter media should

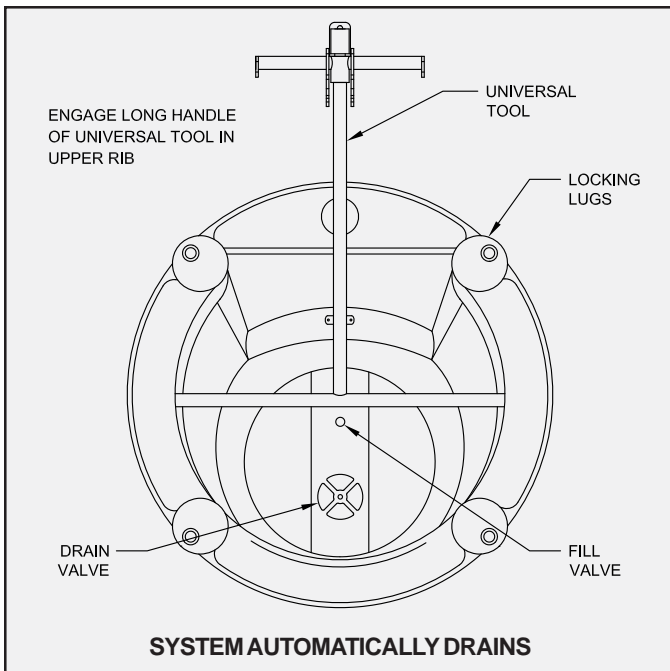

be clean in appearance if the hydraulic loading has never been great enough to cause the liquid level in the clarification chamber to rise above the design flow filter media. If a temporary hydraulic surge has occurred, a dark line will be visible on the peak flow filter media. Note the system water level on the Service Inspection Card.

8. Unscrew the discharge flange assembly and remove both pieces. It may be necessary to hold the inside threaded flange to unscrew the two pieces. After both pieces of the discharge flange are removed, place the internal components back into the Bio-Kinetic system.

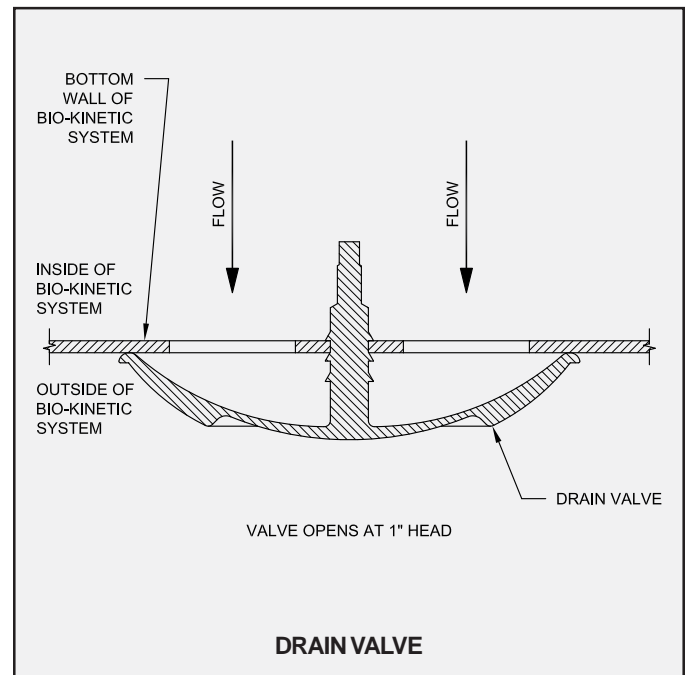

9. Place the Bio-Kinetic system into the service container. The outlet of the Bio-Kinetic system must align with the flat panel in the container. Thread the discharge flange assembly together and place it on the flow deck. Now put the service container cover in place.
10. Reinstall the Singulair aerator as outlined in the Aerator Installation instructions. The aerator must be in operation while the remaining clarification chamber service is performed.
11. Check the surface of the clarification chamber for grease or biologically untreatable material. A significant accumulation of these materials indicates

MANUFACTURED BY

norweco®

Engineering the future of water
and wastewater treatment

NORWECO, INC.
NORWALK, OHIO
U.S.A. 44857

www.norweco.com

SINGULAIR GREEN® BIO-KINETIC®

WASTEWATER TREATMENT SYSTEM

CLARIFICATION AND BIO-KINETIC® SERVICE (Page 3 of 6)

the pretreatment chamber should be evaluated to determine if pumping is required. With the aerator running, use the hopper scraping tool to gently scrape all areas of the clarification chamber hopper side walls. Scrape all the way down to the bottom of the chamber, below the discharge of the Bio-Static sludge return. Then scrape the small flat area at the bottom of the hopper, pushing toward the aeration chamber as far as possible.

is a problem with drainage. Improper drainage will lead to flooding of the Singulair Green Bio-Kinetic wastewater treatment system and must be reported to the owner. Examine the inside of the access riser for evidence of surface water entry.

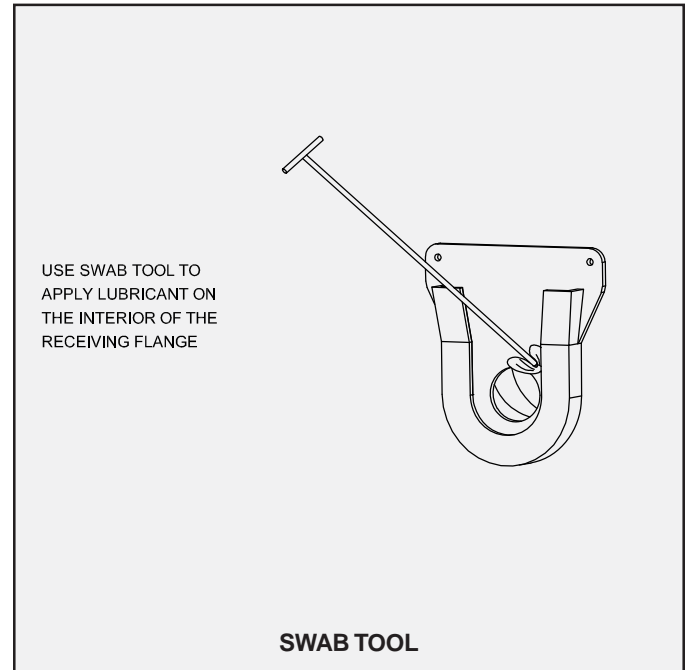
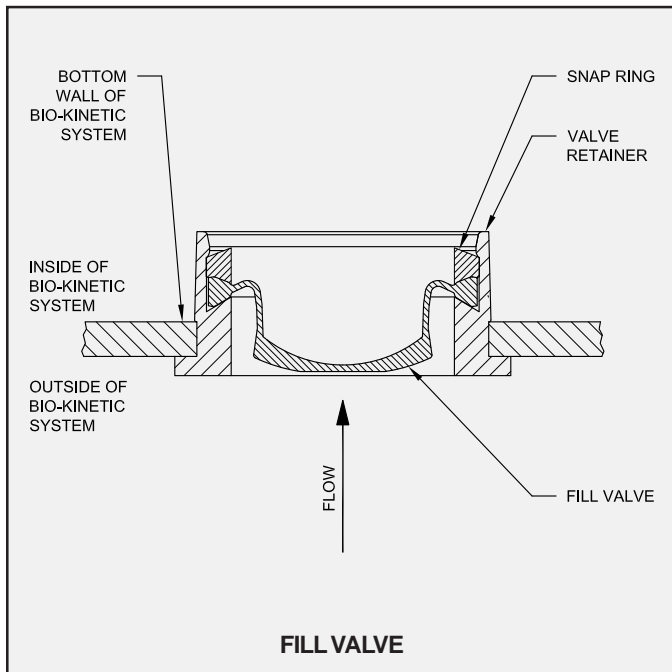

12. If the Singulair Green tank is pumped during system service, the pressure sensitive fill valve will fill the Bio-Kinetic system automatically as the tank refills.

NOTE: It is important that the clarification chamber side walls be cleaned only after the aerator has been serviced and reinstalled. The aerator must be operating so that settled sludge will be fully returned to the aeration chamber by the hydraulic currents flowing through the Bio-Static sludge return.

13. Visually check the Bio-Static sludge return to insure that it is securely engaged in the aeration/clarification chamber wall.
14. If necessary, use water to wash away any sludge from the inside of the system mounting riser, grade riser, cover and surrounding grass or landscaping.
15. Note the liquid level in the clarification chamber. If the liquid level is above the flow line of the outlet coupling, consult the troubleshooting guide to determine if there

16. Examine the condition of the Singulair Green tank receiving flange. Any debris that has accumulated in the grooves of the receiving flange must be removed. Wipe the face of the receiving flange and the internal surface of the grooves clean. Using the swab tool, apply a liberal amount of Bio-Kinetic lubricant to the entire face of the receiving flange and the inside of the grooves. Apply the lubricant evenly until all interior surfaces of the receiving flange and grooves are thoroughly coated.

CAUTION: Bio-Kinetic lubricant has been specially formulated. Use of other lubricants, especially petroleum based lubricants, can cause degradation of the rubber components and will void the warranty.

17. Remove the discharge flange assembly and internal components from the exchange Bio-Kinetic system. Lubricate the grommet in the outlet opening of the Bio-Kinetic system. From the inside of the contact chamber, insert the male threaded flange through the grommet. Reinstall the gasketed discharge flange on the Bio-Kinetic system by turning it clockwise until tight. Reinstall the flow deck and internal components into the contact chamber. Apply lubricant to the exterior surfaces of the gasketed discharge flange.

CLARIFICATION AND BIO-KINETIC® SERVICE (Page 4 of 6)

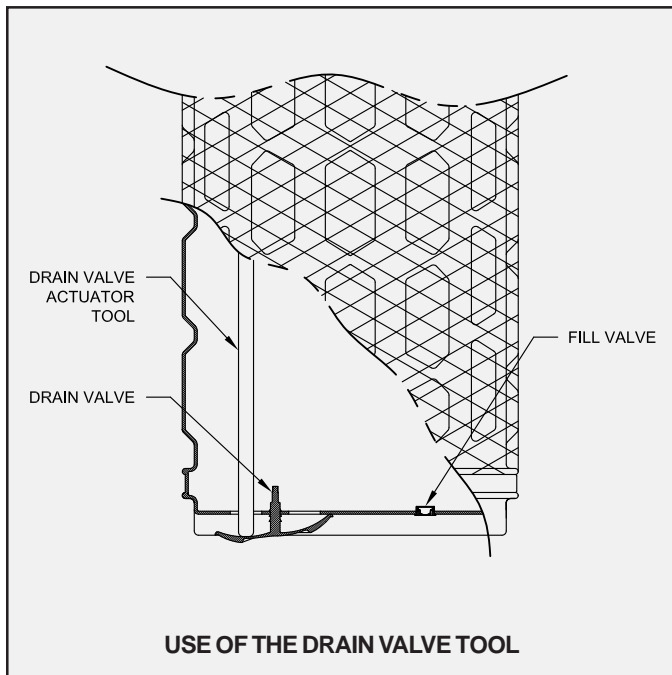

NOTE: Leveling of the flow distribution deck is essential for proper operation of the flow equalization ports, chemical feed tubes and effluent weir within the Bio-Kinetic system.

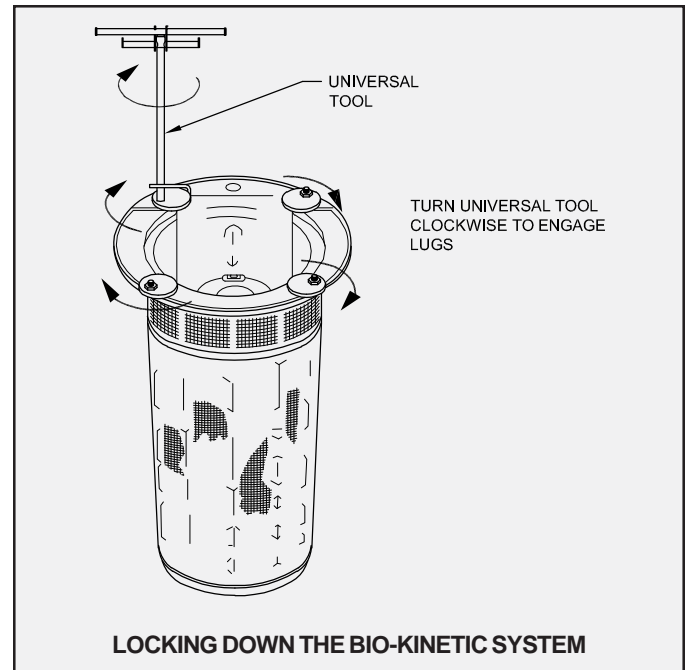

18. Remove the internal components from the replacement Bio-Kinetic system and set aside. Use the universal tool to lower the exchange Bio-Kinetic system outer chamber into the mounting riser. Carefully insert the tip of the drain valve actuating tool through the drain valve located in the bottom of the outer chamber of the Bio-Kinetic system. This will allow the Bio-Kinetic system to fill with water as it is lowered into position. If allowed to tilt, the Bio-Kinetic system could rub the edge of the access opening and damage the filter media. Align the discharge flange with the receiving flange. As the chamber is set into position on the ledge of the access opening, the Bio-Kinetic system discharge flange must engage the top of the receiving flange before proceeding.
19. Once in the proper position, carefully remove both the drain valve actuating tool and the universal tool. This will allow the drain valve to seal against the exterior bottom of the Bio-Kinetic system. Use the locking lug tool to twist each of the round, black locking lugs clockwise so that each of the lugs is rotated to the furthest extension point possible and is engaged in the molded locking slots of the mounting riser.
20. Reinsert the internal components from the replacement Bio-Kinetic system. Locate the level indicator mounted above the outlet of the Bio-Kinetic system flow distribution deck. The bubble should be resting squarely between the two lines in the clear plastic case. If the location of the bubble indicates the system is not installed in a level position, the flow deck should be leveled using the four adjustment lugs provided for this purpose. With the ratchet drive, extension and $\frac{7}{16}$ " socket from the Tool Kaddy, turn each of the adjustment lugs until the bubble comes to rest squarely between the two lines in the clear plastic case.

21. Remove the Bio-Kinetic system outlet sealing tool from in between the system outlet flange and the receiving flange of the Singulair Green tank.
22. The system service cover with information tag from the originally installed Bio-Kinetic system must be reinstalled in the tank. Install the cover, handle side up, by aligning the four holes in the cover with the four locking lug bolts. Be sure the optional chlorination and dechlorination feed tube access openings are in the proper position. The cover will come to rest on the collar of the Bio-Kinetic system. There is no need to add fasteners to the locking lug bolts.
23. If the installation requires effluent disinfection, the chlorine feed tube opening in the service cover must be positioned on the inlet side of the system nearest the aerator mounting riser. The Bio-Kinetic system chlorine feed tube should be filled with Norweco Blue Crystal disinfecting tablets. Blue Crystal tablets have been specially formulated for use in the Bio-Kinetic system, other disinfecting chemicals will not provide the same results. Before handling Blue Crystal disinfecting tablets, carefully read the container

MANUFACTURED BY

norweco®

Engineering the future of water
and wastewater treatment

**NORWECO, INC.
NORWALK, OHIO
U.S.A. 44857**

www.norweco.com

SINGULAIR GREEN® BIO-KINETIC®

WASTEWATER TREATMENT SYSTEM

CLARIFICATION AND BIO-KINETIC® SERVICE (Page 5 of 6)

label and the "Warning" section of these instructions. To fill the chlorine feed tube, remove the cap, hold the tube open end down with one hand and insert Blue Crystal disinfecting tablets, one tablet at a time, until the tube is filled. The tube holds approximately a six-month supply and each tablet must lie flat in the stack. When the tube has been completely filled, replace the cap. Install the feed tube, slotted end down, through the plastic collar molded into the top of the Bio-Kinetic system service cover. The feed tube will begin to engage the round recess in the flow distribution deck. Rotate the tube clockwise until it locks into position.

either safety goggles or a face shield when handling Blue Crystal disinfecting tablets or working with the chlorine feed tube. Keep tablets out of the reach of children, as they can cause skin and eye damage, be irritating to the nose and throat, and may be fatal if swallowed. Avoid breathing dust and do not allow contact with eyes, skin or clothing. Contaminated clothing should be removed and washed before reuse. If tablets or residue contact skin, wash with plenty of soap and water for fifteen minutes. If irritation continues, call a physician. If swallowed, immediately drink large quantities of water, do not induce vomiting, avoid alcohol and get medical attention immediately. If inhaled, immediately remove victim to fresh air. In case of fire, apply liberal quantities of water. It is a violation of Federal law to use Blue Crystal disinfecting tablets in a manner inconsistent with the instructions printed on the storage container label.

24. If the installation requires effluent dechlorination, the Bio-Kinetic system will be supplied with a dechlorination feed tube. To fill the dechlorination feed tube, remove the cap, hold the tube open end down with

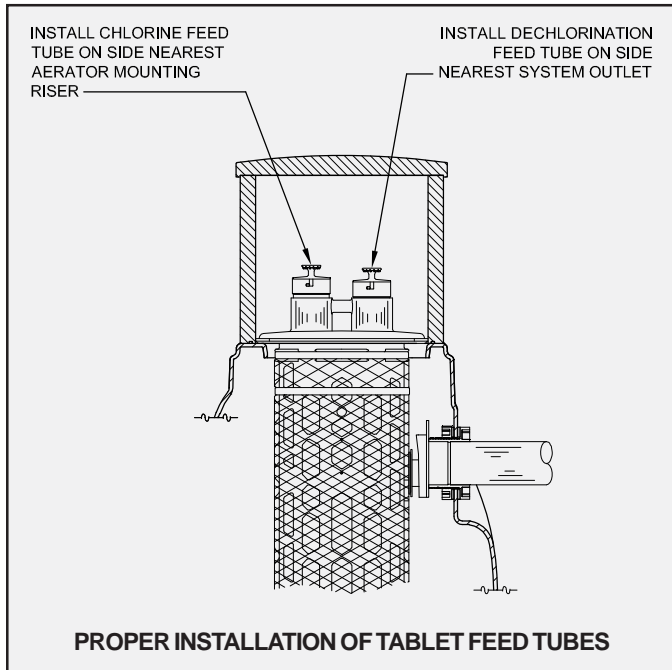

NOTE: The chlorine feed tube must always be installed through the mounting collar nearest the aerator mounting riser. If the installation requires disinfection and dechlorination, there will be two feed tube mounting collars molded into the protective cover. The dechlorination feed tube must be installed nearest the system outlet.

WARNING

Blue Crystal disinfecting tablets are a strong oxidizing agent and highly corrosive. Tablets should be stored in a cool, dry, well-ventilated area away from combustible materials such as paper, petroleum products, chemicals, rags or cardboard. Tablets should be mixed only with water. Contact with other liquids or chemicals may cause fire. Wear rubber gloves and

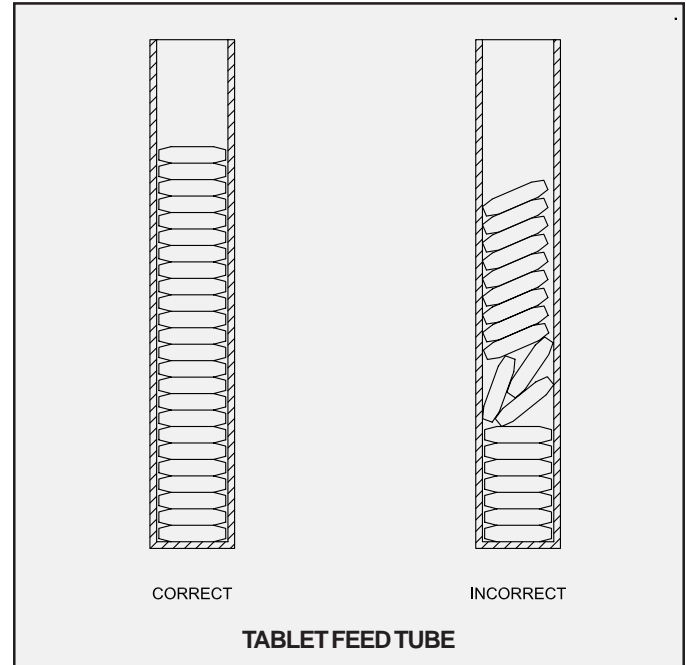

one hand and insert the Bio-Neutralizer dechlorination tablets, one tablet at a time, until the tube is filled. The tube holds approximately a six-month supply of tablets and each tablet must lie flat in the stack. When the tube has been completely filled, replace the cap and insert the dechlorination feed tube, slotted end down, into the mounting collar closest to the system outlet. The bottom of the tube must come to rest evenly on the floor of the flow distribution deck.

CLARIFICATION AND BIO-KINETIC® SERVICE (Page 6 of 6)

WARNING

Bio-Neutralizer dechlorination tablets must be stored in a cool, dry place away from acids and oxidizers. Do not allow Bio-Neutralizer tablets to come into contact with chlorine tablets. Although not rated a hazardous material by the USEPA, exercise caution when handling and wash skin thoroughly with soap and water if contact occurs.

25. Reinstall the clarification chamber access cover. If the installation requires effluent disinfection and/or dechlorination, note the quantity of tablets installed on the Service Inspection Card in order to properly invoice the customer for the appropriate chemical tablets. Clean and store all tools and supplies.
26. When the service is complete, confirm the selector switch in the control center is in the "on" position. Close the cover of the control center enclosure and secure it with a new tamper evident seal.

EFFLUENT DISPOSAL SYSTEM CHECK

1. Determine if the effluent from the Singulair Green system is being carried to an outlet for surface and/or subsurface discharge, or if it is being disposed of on lot. Inspect the condition of the effluent disposal system and make appropriate notations on the Service Inspection Card.
2. Although the Singulair Green system effluent may be discharged and/or disposed of in several acceptable fashions, there should always be a ground water relief point installed in the effluent line. It should be located at a point no higher than the outlet invert of the Singulair Green tank. It will prevent flooding in cases where the disposal line is submerged or saturated with ground water. Locate the ground water relief point and be sure that it is free of obstructions.
3. Locate the point of discharge closest to the Singulair Green system outlet. A free-falling "grab" sample of effluent can be collected after the point of discharge has been thoroughly cleaned. Take note of effluent color, odor and the presence or absence of suspended particles. Accumulation of mud in the effluent disposal line or at its outlet can be a sign of a crushed or broken effluent line and should be reported to the owner. Foaming, odor or particulate sediment indicates that the Singulair Green system has not been providing adequate treatment. Recheck the entire system by using the Singulair Green Troubleshooting guide.

NOTE: An effluent "grab" sample allows a visual assessment and should only be used in conjunction with routine service and/or troubleshooting procedures to accurately evaluate system operation. A "composite"

sample, collected over 24 hours of system operation, preserved and transported using USEPA established procedures, is necessary if laboratory analysis of the effluent is to be performed. Laboratory analysis of an effluent "grab" sample can lead to misleading conclusions about system operation and should not be conducted. For further information regarding proper evaluation techniques for sampling onsite systems, refer to the Norweco Technical Bulletin EFFLUENT SAMPLING TECHNIQUES FOR RESIDENTIAL TREATMENT SYSTEMS.

4. Make appropriate notations on the condition of the plant effluent and disposal system on the Service Inspection Card.

BEFORE YOU LEAVE THE FACILITY...

1. Make sure that both sides of all three Service Inspection Cards are properly and completely filled out, including any specific notes or special services that your inspection indicates are needed.
2. Leave the top section of the Service Inspection Card with the owner and provide a brief verbal explanation of the condition of the system. Advise when to expect your next routine visit and provide your business card with office phone number, should the owner have any questions.
3. Point out the advantages of a continued service policy with your company if the warranty or current service policy is nearing expiration.
4. Explain that the Singulair aerator is set to operate on a time cycle and should not be turned off even during extended periods of non-use. Explain also that the Service Pro control center contains no user-serviceable parts and that the cover is secured with a tamper evident seal both for owner protection and protection of component parts.
5. Review the operation of the red warning light and audible alarm on the Service Pro control center with the owner. Inform the owner that the control center should be checked daily to insure proper system operation. Explain that if the light flashes and the alarm sounds, it could be due to temporary high water or electrical power fluctuation and that the reset button should be pushed to see if normal operation is resumed before requesting special service.

MANUFACTURED BY

norweco®

Engineering the future of water
and wastewater treatment

**NORWECO, INC.
NORWALK, OHIO
U.S.A. 44857**

www.norweco.com