

# PARTS LIST AND REFERENCE

## EXPLODED VIEW

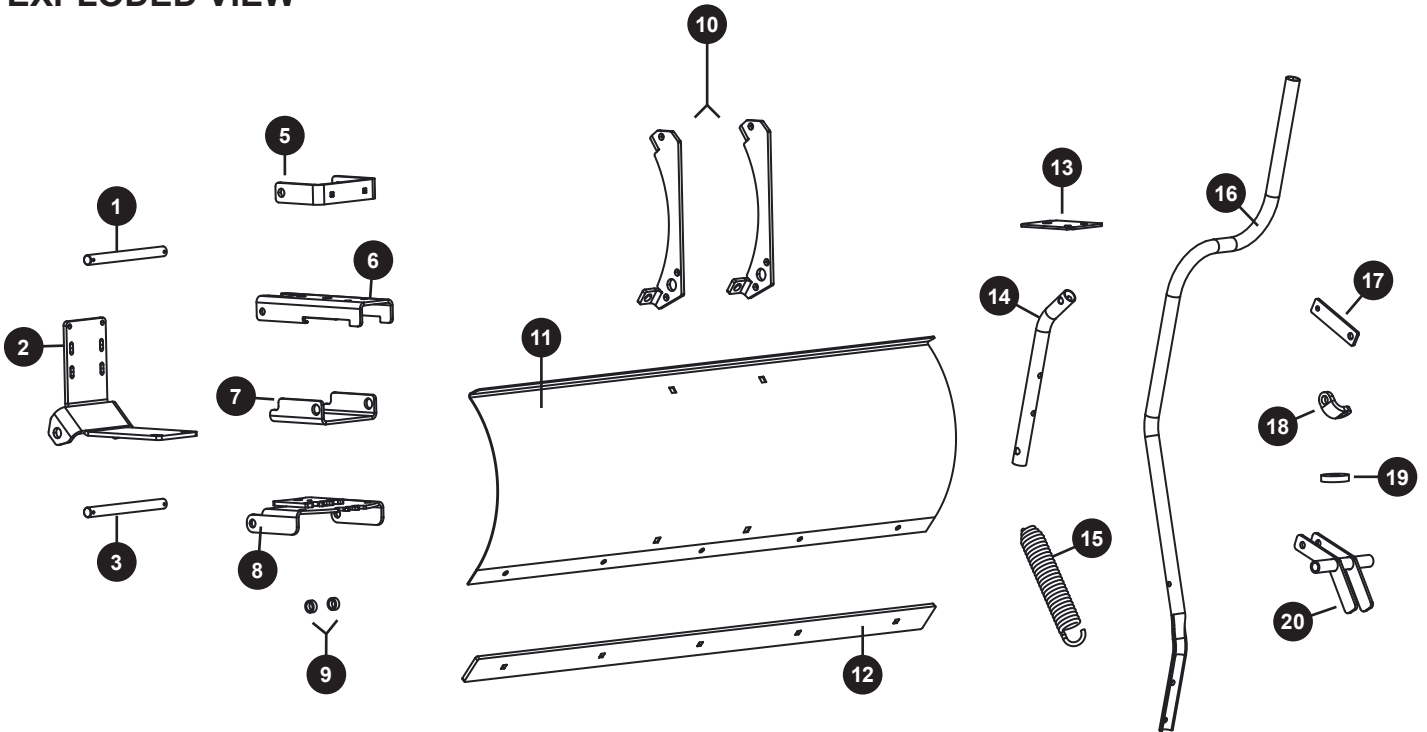

REF	PART NO.	DESCRIPTION	QTY	REF	PART NO.	DESCRIPTION	QTY
1	1017741-01	Rod, Hinge Plated	1	11	1018347	Blade, 42"	1
2	1017835-10	Painted Mount, Front	1	12	1018118-10	Wear Bar, 42" Painted	1
3	1018092-01	Rod, Transport Plated	1	13	1018119-10	Painted Plate, Bottom	1
4	1018104	Hardware Bag *	1	14	1018120-10	Painted Tube, Raise	1
	1018352	Parts Bag *	1	15	1018121	Trip Spring	1
5	1018105-10	Painted Bracket, Pivot	1	16	1018122-10	Painted Tube, Handle	1
6	1018109-10	Painted Bracket, Lower PV	1	17	1018123-10	Painted Plate, Handle	1
7	1018110-10	Painted, Bracket Up Pivot	1	18	B-7215-10	Spring Bracket	1
8	1018111-10	Painted, Hinge Weldment	1	19	B-723P-01	Thick Washer, 3/8"	1
9	1018115-01	Tube, Pivot Plated	2	20	1018106-10	Painted Cam Weldment	1
10	1018116-10	Ribs, Painted	2				

\* Not shown



### Tools Required for Assembly:

- 3/4" Socket & Wrench
- 9/16" Socket & Wrench
- 1/2" Socket & Wrench
- 7/16" Socket & Wrench
- 12 mm Wrench
- Ratchet Wrench
- Pliers
- Gloves

# PARTS LIST AND REFERENCE

## EXPLODED VIEW - HARDWARE BAG

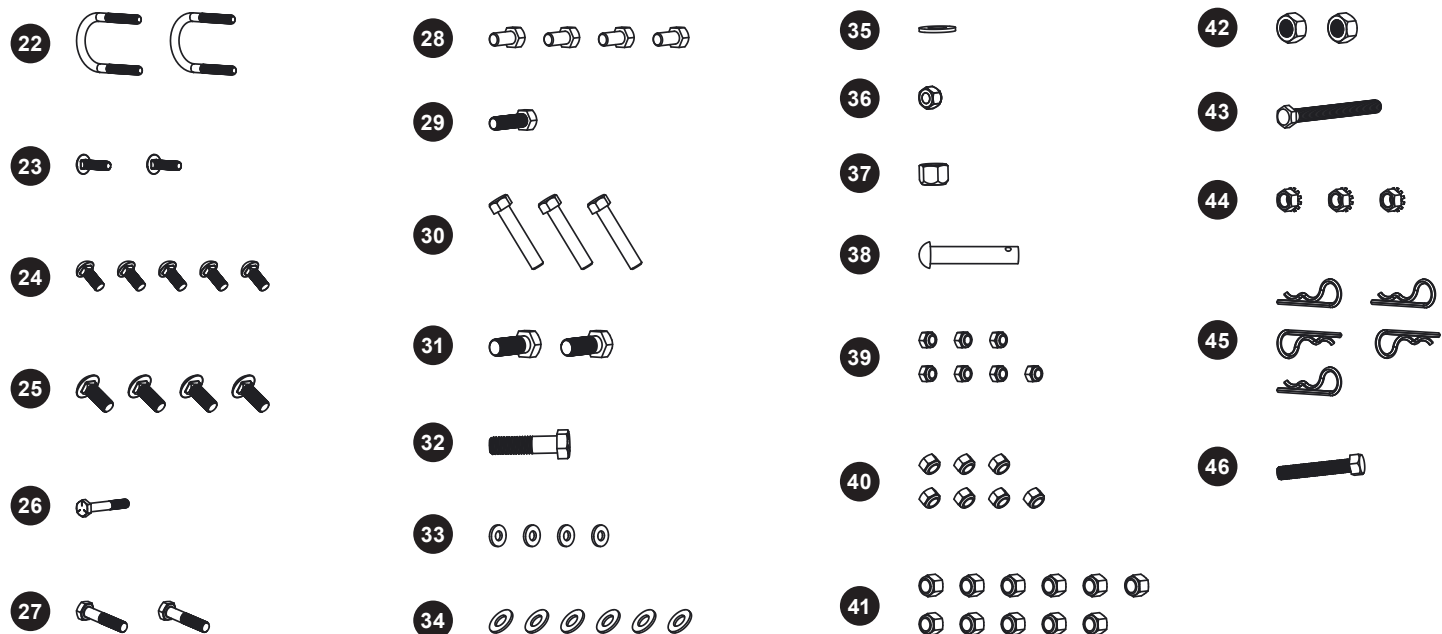

REF	PART NO.	DESCRIPTION	QTY	REF	PART NO.	DESCRIPTION	QTY
21	1000225	Handle Grip *	1	35	45M1717P	Washer, Flat 1/2"	1
22	1017742	U-bolt	2	36	B-1675P	Nut, Hex Lock, 3/8"-16	2
23	11M0816P	Bolt, Carriage 1/4" x 1"	2	37	B-1677P	Nut, Hex Lock, 1/2"-13	1
24	11M1012P	Bolt, Carriage 5/16 x 3/4	5	38	B-3861	Pin, Hitch 1/2" X 2-1/2"	1
25	11M1216P	Bolt, Carriage 3/8 x 1	4	39	B-4785	Nut, Nylon Lock 1/4-20	7
26	2M0828P	Bolt, Hex Head 1/4 x 1-3/4	1	40	B-4786	Nut, Nylon Lock 5/16-18	7
27	2M1024P	Bolt, Hex Head 5/16 x 1-1/2	2	41	B-4820	Nut, Nylon Lock, 3/8"-16	11
28	2M1212P	Bolt, Hex Head 3/8 x 3/4	4	42	B-5096Y	Nut, Nylon Lock, 1/2"-13	2
29	2M1220P	Bolt, Hex Head 3/8 x 1-1/4	1	43	B-6298	Bolt, Hex Hd 3/8 x 3-3/4	1
30	2M1232P	Bolt, Hex Head 3/8 x 2	3	44	B-6299	Nut, Keps Hex, 3/8-16	3
31	2M1620P	Bolt, Hex Head 1/2 x 1-1/4	2	45	D-146P	Hairpin Cotter, 1/8", #211	5
32	2M1632P	Bolt, Hex Head 1/2 x 2	1	46	B-7291	Bolt, 3/8 x 2-1/2	1
33	45M0909P	Washer, SAE Flat, 1/4"	4				
34	45M1313P	Washer, SAE Flat-3/8	6				

\* Not shown

Each spread of the assembly has a guide to help with hardware identification.

**THIS SECTION CAN BE USED TO IDENTIFY BOLTS:**

Check the bolt size by placing the head or the threaded end over the matching diagrams to the left.



Example =  
Hex Head Bolt  
1/4" x 1"

**THIS SECTION CAN ALSO ASSIST WITH IDENTIFYING WASHERS:**

Exterior circumference of washers can vary. *These dimensions are a measurement of the internal diameter of the washer.*

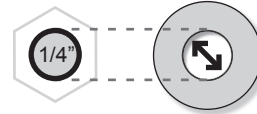

Example =  
1/4" Washer

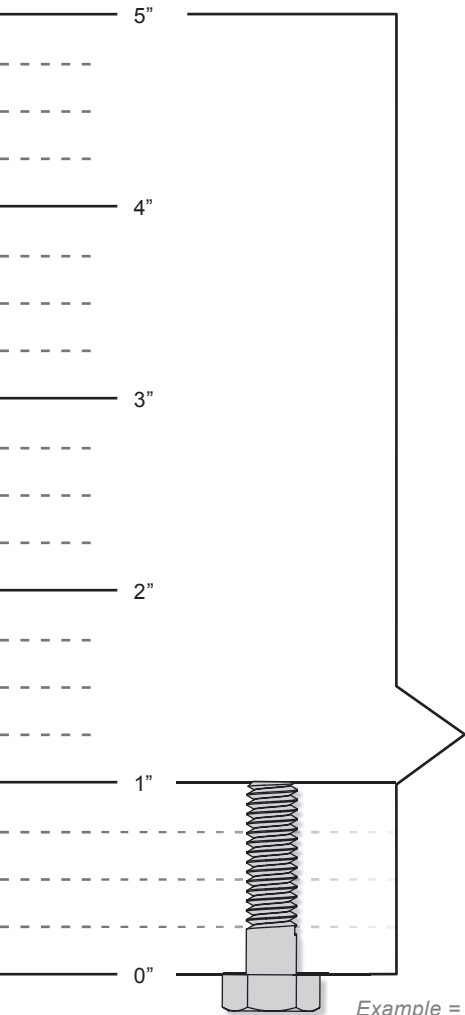
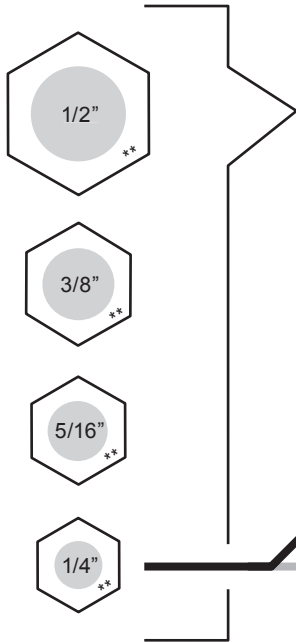

**THIS SECTION CAN BE USED TO IDENTIFY BOLTS:**

Check the bolt length by measuring the length of each bolt with this ruler.

Example =  
Hex Head Bolt  
1/4" x 1"