

# Eoslift

CE

High Lift Pallet Truck Hand operated  
Operating Instructions  
I10D I15D

---

Before use, Always read Instructions And procedures Carefully for safe operation

---



**High Lift Pallet Truck  
Hand operated**

I10D I15D

**Eoslift Automation Technology Corp.  
No.99, Yanjia Road, Yuantong Town, Haiyan, Zhejiang**

**Year of Manufacture: 2016**



Part No.	DESCRIPTION	QTY	Part No.	DESCRIPTION	QTY
162	Ball	1	163	Snap Ring	1
164	Washer	1	170	Bush	2
171	Piston	1	172	Screw	1
173	Axle	1	174	Gasket	1
175	Lock Screw	1	176	Rubber Sleeve	1
177	Washer	1	178	Washer	5
180	Adjusting Screw	1	181	Handle Base	1
182	Adjusting Washer	1	183	Rubber Sleeve	1
184	Spring Guide	1	185	Screw	3
186	Spring Washer	3	189	Spacer	2
190	Copper Piston	1	191	Snap Ring	1
192	Snap Ring	2	301	Bush	1
302	Back-Up ring	1	303	Y-Ring	1
304	Bush	1	305	Snap Ring	1
306	Piston Rod	1	307	Cylinder Head	1
308	Lifting Ram	1			
300	<p style="text-align: center;">Pump unit</p> (incls.71,72,73,74,75,104,105,111,112,117,118,119,120,121,122,123,124,125,126,127,128,129,130,131,132,133,134,135,136,137,138,139,140,141,142,143,144,145,146,147,148,149,150,153,155,157,158,159,160,163,164,170,171,172,173,174,175,176,177,180,181,182,183,184,185,186,190,191,192,301,302,303,304,305,306,307,308)				1
50	<p style="text-align: center;">Handle assembly</p> (incls.101,102,103,106,107,108,109,110,113,114,115,116,178,187,188,189,193,194,195)				1

\* VERSION THREE  
2012-12-20

## Specifications

Model	I10D		I15D	
Rated lifting capacity	1000 kg		1500 kg	
Max. Fork height	800 mm		800 mm	
Min. Fork height	85 ±2 mm		85 ±2 mm	
Fork length	1140 mm		1100 mm	
Fork width (outside)	520 mm	680 mm	520 mm	680 mm
Fork width (inside)	196 mm	356 mm	196 mm	356 mm
Lifting speed	9 mm/stroke			
Descending speed	∠ 0.1 mm/second			
N.W.	105 kg	112 kg	118 kg	125 kg

## Safety Instructions

- The truck shall be used in accordance with instructions handbook.
- Don't put the hand & foot under the fork at any time.
- Don't work on the slope surface.
- Quick lifting is prohibited for loads of more than 300 kgs. Any manipulation of the pressure relief valve is strictly prohibited. All assembling, adjusting and maintenance shall only be done by industrial mechanics trained people. These people must be familiar with all safety regulations of European and national where the item is in use relating to the operation and maintenance of pedestrian controlled industrial trucks.
- Load should be put on the fork center. Side-load is strictly prohibited.
- The truck shall not be used to transport persons.
- It is recommended to the driver to wear security shoes.
- No modifications shall be carried out which adversely affect the compliance of the truck with prEN 1757-4.

## Installation & Adjustment

### 1. Screw(part No.158)

- To prevent oil-leaking from oil tank during transportation, Air Screw (part No.158) is replaced with Oil-sealing Screw in the factory. But it has to be replaced back when you put this truck in use.
- How to change: Screw out Oil-sealing Screw, then screw in Air Screw With which the Pump housing(No.160) is hung, thus keep oil tank always connecting with atmosphere.

### 2. Handle

During transportation, the handle is disassembled from the truck and packed separately. It has to be assembled back and adjusted properly and carefully before use.

### A Handle installation:

- Take 3 pieces of M10 Nut (No.185) & Spring washer from spare parts bag.  
Select handle to match the truck with the same fitting numbers.
- Assemble the handle on the Handle Base (No.181) with 3 pieces of M10 Nut & Spring Washer tightly.
- Put the chain's Eye Bolt (No.110) in the slot at the front end of Pendulum Arm (No.112).

### B Handle adjustment

- There are 3 different positions with different functions for the Release Lever (part No.46).  
See picture 1

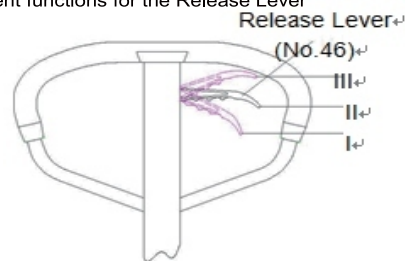

Position I: Quick lifting for fork.

Position II: Slow lifting for fork.

Position III: Descending for fork.

- **Test different functions by putting the Release Lever in 3 different positions respectively.**

If it does not function properly, then adjusting

Lock Nut (No.113) by following process. See picture 2

Problems	Turning direction of Lock Nut
Fork not lifted up	- (counter-clockwise)
Fork not lowering down	+ (clockwise)
Slow lifting no function	+ (clockwise)
Quick lifting no function	- (counter-clockwise)

- **Function of Adjusting Screw (No.187) for Release Lever (see picture 1)**

To fix release lever (No.46) into its 3 positions properly by adjusting the screw, you can adjust the operating force of the release lever.

To prevent accidental touch of the Release Lever which could cause sudden sliding down of the fork. You can tighten the Screw (No.187) in the position I or II of the Release Lever (No.46).

See picture 1

## Parts list

Part No.	DESCRIPTION	QTY	Part No.	DESCRIPTION	QTY
71	Washer	1	72	Spring	1
73	Bush	2	74	Washer	1
75	Gasket	1	101	Locknut	1
102	Handle	1	103	Screw	1
104	Pin	1	105	Roller	1
106	Release Lever	1	107	Release Rod	1
108	Chain Connector	3	109	Chain	1
110	Eye Bolt	1	※ 111	Washer	1
112	Pendulum Arm	1	113	Pendulum Arm Nut	1
114	Positioner	1	115	Screw	5
116	Washer	2	117	Pin	1
118	Valve Insert	1	119	Seat	1
120	Screw	2	121	Gasket	2
122	Spring	2	123	Release Valve	2
124	Ball	2	125	Valve Insert	1
126	O-Ring	8	127	Spring	1
※ 128	O-Ring	1	129	Release Indicator	1
※ 130	Screw	1	131	Pump Piston	1
132	Guide Ring	1	133	Y-Ring	1
134	Washer	1	135	Snap Ring	1
136	Scraper Ring	2	137	O-Ring	2
138	Y-Ring	2	139	Pump Cylinder	1
140	O-Ring	1	141	Spring	1
142	Hi-pressure Piston	1	143	O-Ring	1
144	Ball	1	145	Spring	1
146	Adjusting Screw	1	147	Sealing Screw	1
148	Screw	1	149	Snap Ring	2
150	O-Ring	2	153	O-Ring	1
155	O-Ring	1	157	Screw	1
158	Air Screw	1	159	Cylinder	1
160	Pump Housing	1	161	Thrust Bearing	1

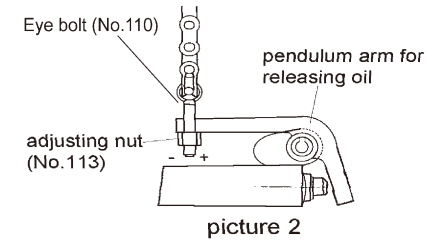
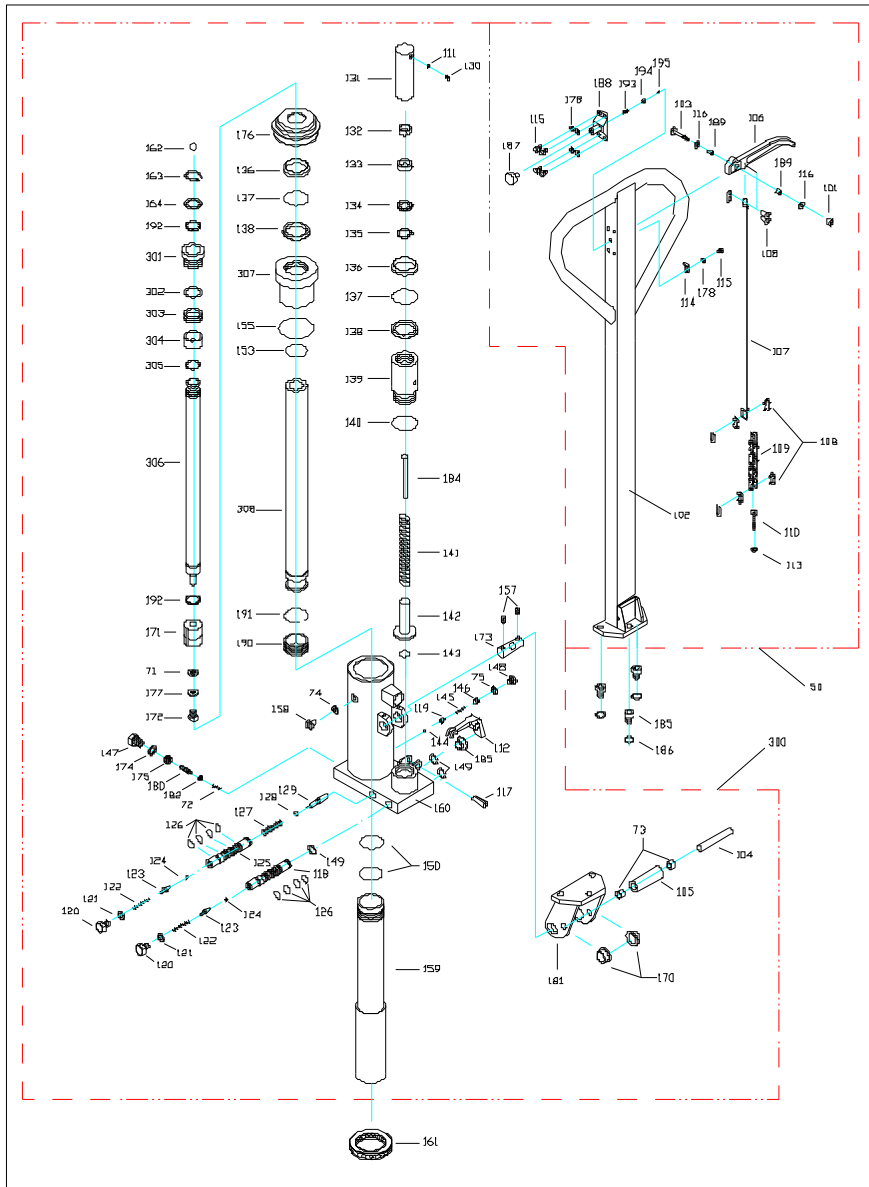

● **How to release the air from the pump.**

See picture 3

When pushing the handle down, the fork can't be lifted instantly. Please loosen the Screw (No.130) on the pump while pushing the handle down slowly to release the air from the pump. Then tighten the screw.

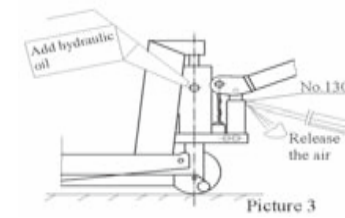

● **When to add oil**

See Picture 3

If the fork can't be pumped up to its rated highest position, you may have to add hydraulic oil into the oil tank. The hydraulic fluid to be used must have a quality of ISO VG22 or equivalence. Mixing of different fluids is prohibited!

## TROUBLE SHOOTING GUIDE

ms	Symptom	Possible cause	Aliments
1	Fork can not be pumped up	1. Low oil level in oil tank. 2. Exist air in the hydraulic system. 3. Adjusting nut is not adjusted properly.	1. Add proper hydraulic oil. 2. Fast operating the handle for several times. Bleed the system. 3. Adjust adjusting nut. (see picture 2)
2	Fork can't be released down	1. Fork blocked. 2. Adjusting nut not adjusted properly.	1. Check and remove the block. 2. Adjust adjusting nut properly. (see picture 2)
3	Fork can't be pumped up to rated highest position.	Oil is not enough.	Add hydraulic oil. (see picture 3)
4	Fork lifting speed has no difference between position I and position II of release lever.	Adjusting nut is not adjusted properly.	Adjust adjusting nut. (see picture 2)

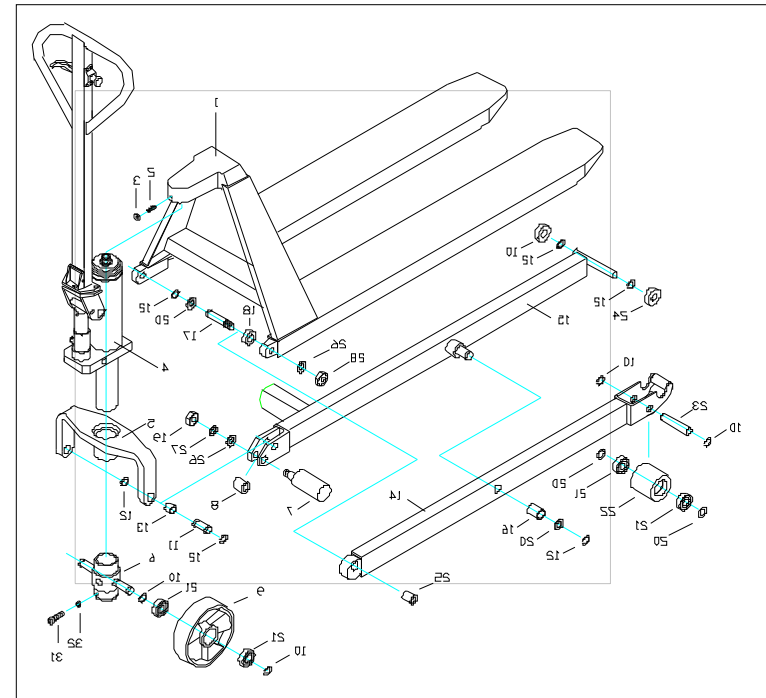

### Parts List

No.	Description	Qt'y	No.	Description	Qt'y
1	Fork	1	18	Washer	2
2	Screw	1	19	Nut	2
3	Nut	1	20	Washer	8
4	Power Unit	1	21	Ball Bearing	8
5	Hold Yoke	1	22	Front Wheel	2
6	Wheel Yoke	1	23	Wheel Axle	2
7	Centrifugal Axle	2	24	Roller	4
8	Spacer	2	25	Bush	2
9	Steering Wheel	2	26	Washer	4
10	Snap Ring	8	27	Spring Washer	2
11	Pin	2	28	Nut	2
12	Snap Ring	12	31	Screw	1
13	Bush	2	32	Nut	1
14	Leg	2	30	Steering Wheel Assembly (incls.6,9,10,21、 31、 32)	1
15	Leg	1			
16	Bush	2			
17	Pin	2			