

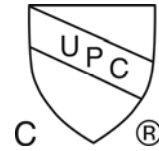

MFF-VCNRT



Installation/Installation/Instalación

VINCENNES

Roman Tub with Hand Shower
Robinet pour bain romain sans douche
Tina romana con ducha



Tools You Will Need / Outils dont vous aurez besoin / Herramientas necesarias



Adjustable Wrench
Clé à molette
Llave ajustable



Groove join pliers
Pince multiprise
Pinzas ajustables

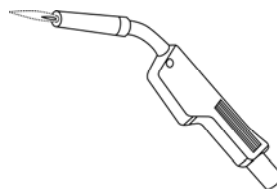

Welding Torch
chalumeau (soudeur)
Pistola

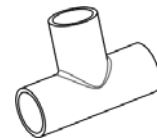

Tee
"T"
Raccord en T

SAFETY TIPS

- If you use soldering for the installation of the faucet, the seats, cartridges and washers will have to be removed before using flame. Otherwise, warranty will be void on those parts.
- Cover your drain to avoid losing parts.

CONSIGNES DE SÉCURITÉ

- Si vous posez le robinet par brasage, il est essentiel de retirer les sièges, les cartouches et les rondelles avant d'appliquer la flamme, faute de quoi la garantie sur ces pièces sera annulée.
- Couvrez le drain pour ne pas perdre des pièces.

CONSEJOS DE SEGURIDAD

- En el caso de utilizar soldadura para instalar el grifo, remueva los asientos, cartuchos y arandelas antes de usar la llama. De lo contrario, se anulará la garantía para esos componentes.
- Tape la boca del desagüe para prevenir la pérdida de piezas pequeñas.

Installation/Installation/Instalación

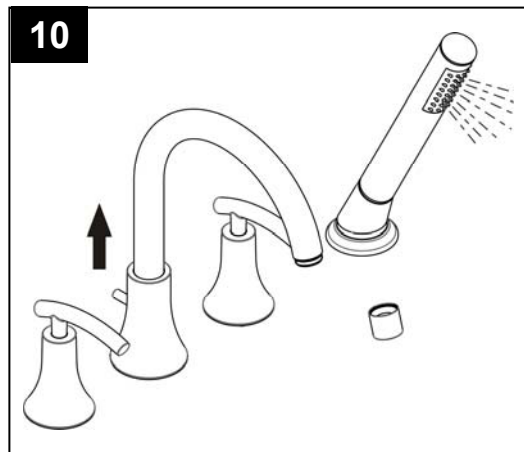
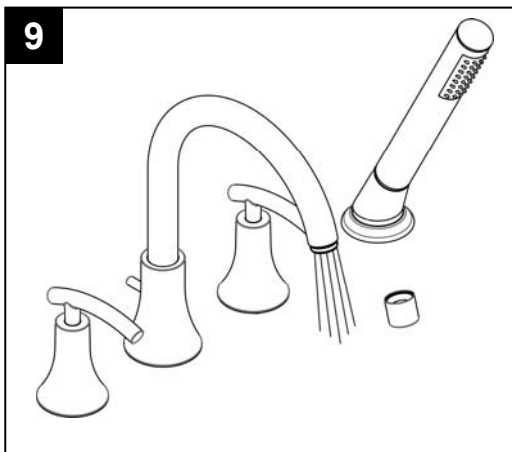
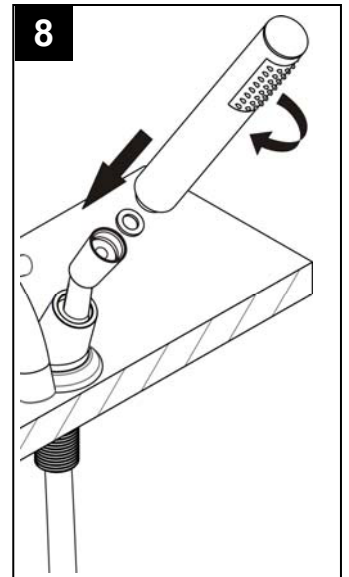
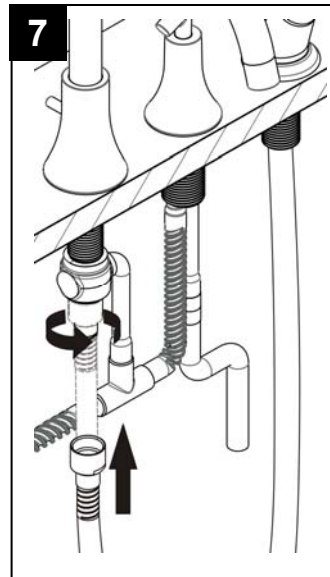
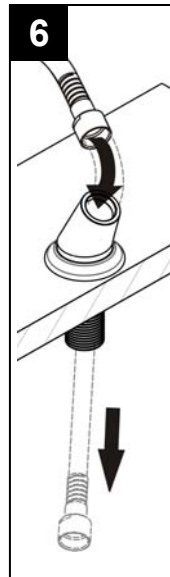
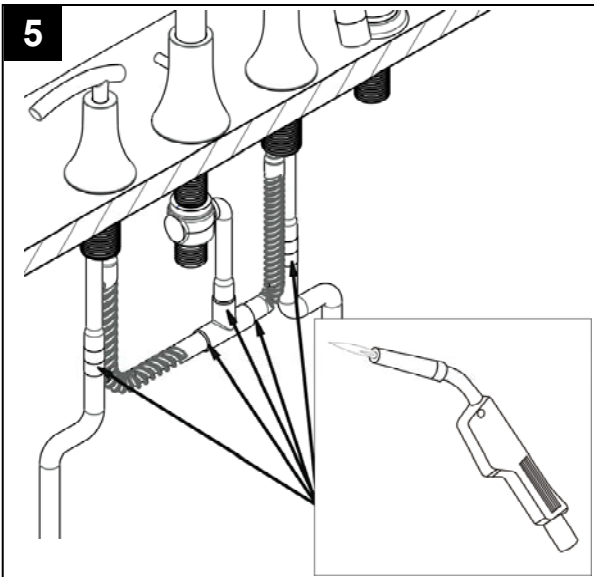
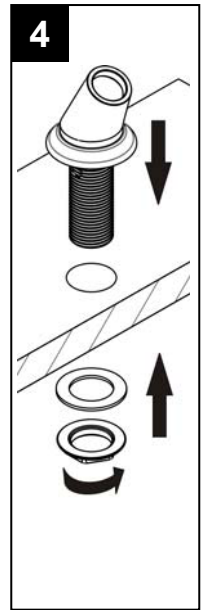
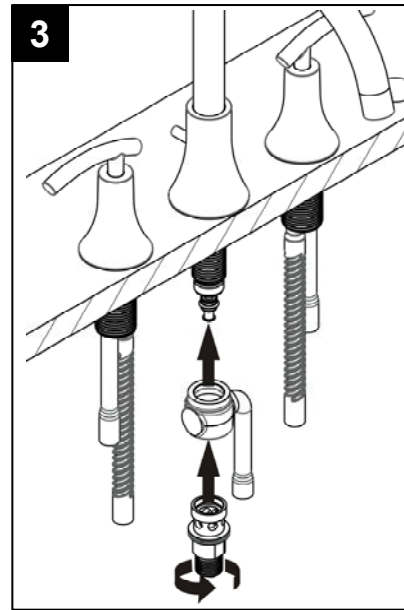
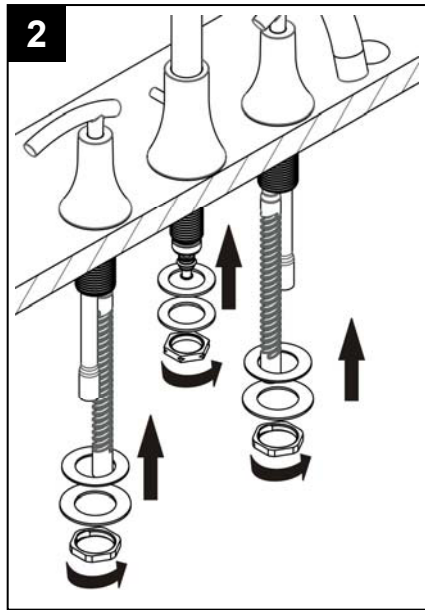
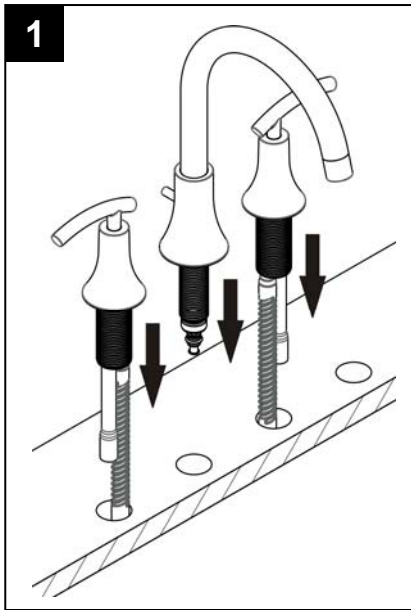

Please keep aerator wrench to allow for removal and cleaning of aerator.

Garder la clé pour brise-jet pour retirer l'aérateur afin de le nettoyer.

Conserve la llave para aireador para quitar y limpiar el aireador.

Trouble-Shooting / Dépannage / Guía de solucionar problemas

If you've followed the instructions carefully and your faucet still does not work properly, take these corrective steps.

Si vous avez suivi attentivement les instructions et que votre robinet ne fonctionne toujours pas correctement, apporter les correctifs suivants.

Si usted ha seguido las instrucciones cuidadosamente y su grifo todavía no funciona correctamente, siga estos pasos correctivos.

Problem/Problème/Problema	Cause/Cause/Causa	Action/Correctif/Solución
Leaks underneath handle.	Retainer nut has come loose. O-ring is dirty or damaged.	Tighten the retainer nut. Clean or replace O-ring.
Fuites sous la manette.	L'écrou de fixation s'est desserré. Le joint torique est sale ou endommagé.	Serrer l'écrou de fixation. Nettoyer ou remplacer le joint torique.
Goteo debajo de la manija.	La tuerca de ajuste se ha aflojado. La arandela circular está sucia o dañada.	Apriete la tuerca de ajuste. Limpie o reemplace la arandela circular.
Aerator leaks or has an inconsistent water flow pattern.	Aerator is dirty or misfitted.	Unscrew aerator, remove any debris, check seating of rubber seal then re-assemble aerator.
Le brise-jet fuit ou la diffusion des jets qui s'en écoulent n'est pas uniforme.	Le brise-jet est mal ajusté ou sale.	Dévisser le brise-jet, le nettoyer, vérifier l'assise de la garniture en caoutchouc et remonter le brise-jet.
El aireador gotea o el chorro de agua está irregular.	El aireador está sucio o mal puesto.	Destornille el aireador, límpielo, revise el asiento del empaque de goma, y vuelva a ensamblar el aireador.

Replacement Parts / Pièces de rechange / Repuestos

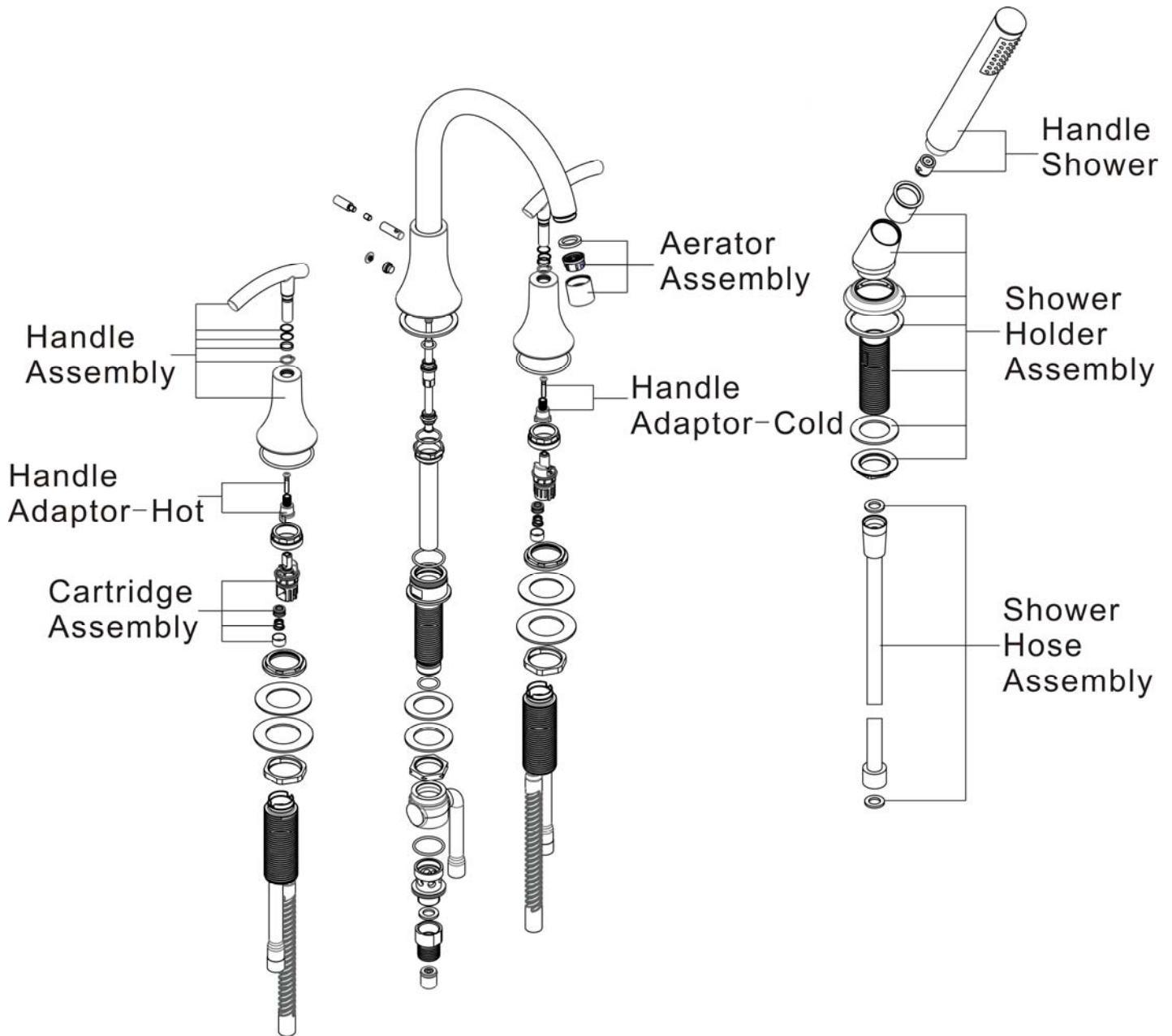

Limited Lifetime Warranty

Italia Faucets, Inc. warrants to the original purchaser that its products will be free from defects in workmanship and materials. All Italia faucets are provided with a limited lifetime warranty. This warranty does not cover any other labor or service charges associated with the removal, repair, or reinstallation of Italia Faucets products. This express warranty does not apply to products that have been damaged as a result of misuse, abuse, negligence, accident, faulty installation or maintenance practices and/or used in any manner contrary to those recommended by the manufacturer.

Need help? Please call our toll-free customer service line at 1-877-482-5422 for additional assistance or service.

Besoin d'aide? Veuillez communiquer avec notre service à la clientèle au numéro gratuit 1-877-482-5422 pour tous renseignements ou services complémentaires.

¿Requiere asistencia? Llame a nuestro Servicio al Cliente, sin costo, al 1-877-482-5422 para asistencia adicional o servicio.