

Item #1001 486 696
Model #0045-0BZ-01FJ

Use and Care Guide

Solar Powered LED Bronze Spotlight

PACKAGE CONTENTS

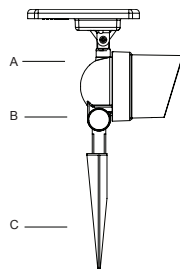

| Part | Description | Quantity |
|------|-------------------|----------|
| A | Solar Top Housing | 1 |
| B | Screw | 1 |
| C | Ground Stake | 1 |

Installation

1 CHOOSING THE RIGHT LOCATION

- Your solar lights should be installed in an area that gets **DIRECT SUNLIGHT**. Your solar lights will produce more hours of operation when installed in an area which is free from cover, shade, or shadowing.

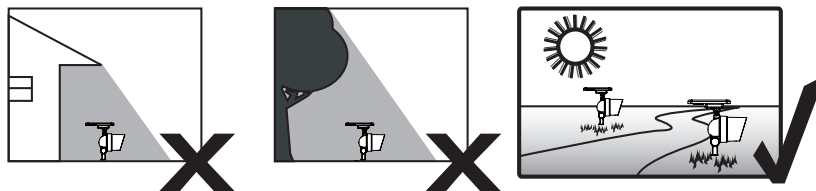

2 ATTACHING THE GROUND STAKE

- Align the ground stake (C) to the screw (B) on the solar top housing (A).
- Tighten the screw (B) using a clockwise motion.

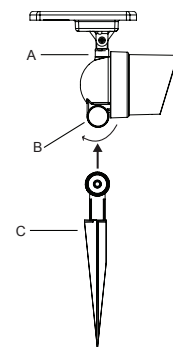

3 TURNING THE SWITCH TO "AUTO"

- Put the switch, located under the solar panel, to the **AUTO** position.

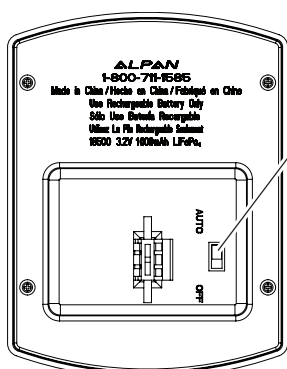

"AUTO/OFF"
Switch

4 INSERTING THE SPOTLIGHT INTO THE GROUND

- Push the spotlight into the ground. Do not push down on the solar panel as this could damage the light.

CAUTION: Do not use hammer. If ground is hard, use water to soften.

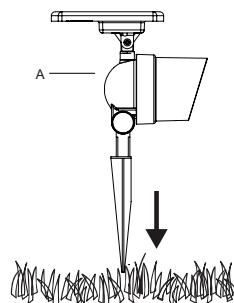

5 YOUR SPOTLIGHT IS READY!

- The more sunlight received during the day, the longer the light will operate that night. Therefore, operating times will vary by specific location, daily weather conditions, and season.

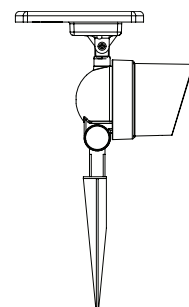

Safety Information

Please note the following important safety notes:

1. The ground stake is sharp. Handle with care to avoid injury.
2. Clean the solar panel with a damp cloth. Do not use any chemicals or abrasives.
3. Keep the solar panel free of dirt and debris.
4. Do not dispose of battery in fire. Dispose of batteries in accordance all local, state and federal regulations.

WARNING: Do not use hammer. If ground is hard, use water to soften.

DANGER: Ground stake is sharp. Handle with care.

IMPORTANT: Dispose of batteries in accordance with all local, state and federal regulations.



HAMPTONBAY.com

Please contact 1-855-HD-HAMPTON for further assistance.

Replacing the Battery

1 REPLACING THE BATTERY

- Remove the solar top assembly (A) from the ground stake (C) by loosening the screw (B) with a counterclockwise motion.

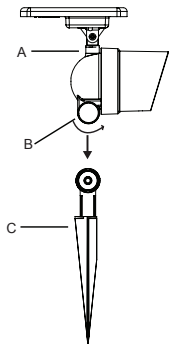

2 REPLACING THE BATTERY (CONTINUED)

- Remove the screws from the bottom of the solar panel (A) using a screwdriver (not included.)

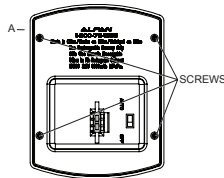

CAUTION: Dispose of battery in accordance with local, state and federal regulations.

DANGER: Do not dispose of battery in fire.

3 REPLACING THE BATTERY (CONTINUED)

- Remove the battery cover (1) on the bottom of the solar panel.
- Remove the battery.



NOTE: Use only Lithium Phosphate 18500 (3.2V 1000mAh) rechargeable batteries.

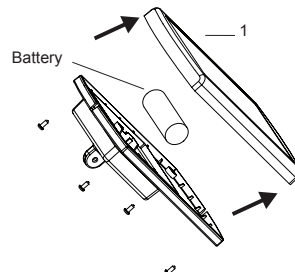

4 REPLACING THE BATTERY (CONTINUED)

- Replace the battery, paying attention to match the correct polarity.
- Reattach the battery cover (1).

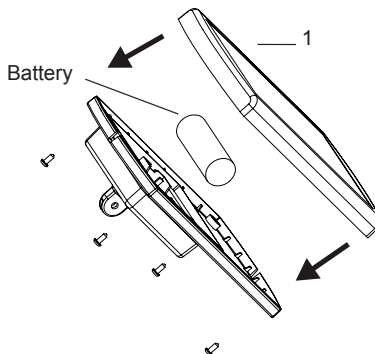

Troubleshooting

| Problem | Solution |
|--|--|
| Light stops working after a period of working properly: | <ul style="list-style-type: none"> -The battery is not adequately charged. Place the unit in direct sunlight for three sunny days. -The lights are located in an area that does not provide enough sunlight. If a tree, house, or other object is shading the solar light, move the light to a sunnier location. Also note that lighting times will always be shorter on overcast days. -The light level is too high for the solar spotlight to turn on. The solar spotlight is designed to turn on when it is dark outside. Make sure the solar top housing is not under any direct light source when testing. -The battery may be weak or can no longer produce a charge. Replace the battery. |
| The light only operates for a short duration in the evening: | <ul style="list-style-type: none"> -The lights are located in an area that does not provide enough sunlight. If a tree, house, or other object is shading the solar light, move the light to a sunnier location. Also note that lighting times will always be shorter on overcast days. -The battery may be weak or can no longer produce a charge. Replace the battery. |

Manufacturer's Limited Two-Year Warranty

WHAT IS COVERED

Manufacturer warrants this product to be free for two (2) years against any defects that are due to faulty materials or workmanship. Manufacturer shall promptly correct such defects by repair or replacement, at its option. This warranty covers only product defects and shall expire one year after the date of purchase by the original purchaser. Proof of Purchase (Sales Receipt) is required.

WHAT IS NOT COVERED

This warranty does not apply to (1) bulbs and batteries or (2) defects caused by and resulting from misuse, neglect, accident or improper operation, maintenance, storage, transportation handling of the product. The warranty does not cover any transportation costs for return of the product or for reshipment of any repaired or replaced product, or cost associated with installation, removal or reinstallation of the product. This warranty extends to the original purchaser only and is not transferable or assignable to subsequent purchasers. This warranty does not cover surface scratches or weathering as this is considered normal wear.

Manufacturer shall have no responsibility for damage to persons or property or other loss or injury resulting from a defect in the product or from improper use or installation. UNDER NO CIRCUMSTANCES SHALL MANUFACTURER BE LIABLE SPECIAL OR CONSEQUENTIAL DAMAGES. ANY WARRANTIES IMPLIED BY LAW, INCLUDING THOSE OF MERCHANTABILITY AND CIRCUMSTANCES SHALL MANUFACTURER BE LIABLE SPECIAL OR CONSEQUENTIAL DAMAGES. ANY WARRANTIES IMPLIED BY LAW, INCLUDING THOSE OF MERCHANTABILITY AND warranty exceed the cost of repair or replacing such defective product, and Manufacturer's maximum liability under any warranty is in lieu of all other warranties expressed or implied.

Some states do not allow the exclusion or limitation of special or consequential damages or allow limitations on how long an implied warranty lasts, so the above limitation may not apply to you. This warranty gives you specific legal rights, and you may have rights that vary from state to state. If you feel you have a claim under this warranty, contact consumer service for advice on handling the claim. Written notice of any defects must be given to Manufacturer upon discovery.

