



Material Safety Data Sheet

Client	SHENZHEN BIYATE ENERGY CO., LTD
Add. of Client	4F, Bldg B-14B, The First Industrial Zone, Baihua Community, Guangming New District, Shenzhen, China
Description	POLYMER LI-ION BATTERY
Model /Type	401121
Manufacturer	SHENZHEN BIYATE ENERGY CO., LTD
Add. of Manufacturer	4F, Bldg B-14B, The First Industrial Zone, Baihua Community, Guangming New District, Shenzhen, China
Nominal Voltage	3.7V, 55mAh, 0.204Wh
Date of Receipt	2015-02-02

Laboratory	Shenzhen ZRLK Testing Technology Co., Ltd.
Address	3F, HengFengYuan Business Building, QunHui Road, Bao'an District, ShenZhen, P.R.C (518101)
Approved Signatory	Williau. liu 
Inspected by	Bella.Wang 
Censored by	Frank. feng 



Section 1- Chemical Product and Company Identification

1. Chemical Product Identification

Product name: POLYMER LI-ION BATTERY

Model: 401121

2. Company Identification

Manufacturer /Supplier Name: SHENZHEN BIYATE ENERGY CO., LTD

Address: 4F, Bldg B-14B, The First Industrial Zone, Baihua Community, Guangming New District, Shenzhen, China

Telephone number of the supplier: 0086-0755-83938415

Emergency Telephone No.(24h): 0086-0755-83938415

e-mail address: info@kinlan.cn

This MSDS was prepared by Shenzhen ZRLK Testing Technology Co., Ltd.

Referenced documents: ISO 11014:2009 Safety data sheet for chemical products;

Section 2 – Hazards Identification

Preparation hazards and classification	When the battery is In extreme pressure deformation, high-temperature environment, overload, short-circuit condition, or disassemble the battery, an explosion of fire and chemical burn hazards may occur.
Apperance, Color, and Odor	Solid object with no odor, no color.
Primary Route(s) of Exposure	These chemicals are contained in a sealed stainless steel enclosure. Risk of exposure occurs only if the cell is mechanically, thermally or electrically abused to the point of compromising the enclosure. If this occurs, exposure to the electrolyte solution contained within can occur by Inhalation, Ingestion, Eye contact and Skin contact
Potential Health Effects:	ACUTE (short term): see Section 8 for exposure controls In the event that this battery has been ruptured, the electrolyte solution contained within the battery would be corrosive and can cause burns. Inhalation: A battery volatilizes no gas unless it was damaged. Damaged battery will volatilize little gas that may stimulate the respiratory tract or cause an anaphylaxis in serious condition. Ingestion: Swallowing battery will be Damaged to the respiratory tract and Cause chemical burns to the stomach; in serious conditions it will cause Permanent damage. Skin: In normal condition, Contact between the battery and skin will not cause any harms. Contact with a damaged battery may cause skin allergies or chemical burns. Eye: in normal condition, Contact between the battery and eyes will not cause any harms. However, the gas Volatilize from a damaged battery may be harmful to eyes. CHRONIC (long term): see Section 11 for additional toxicological data
Medical Conditions Aggravated by Exposure	Not applicable



Reported as carcinogen	Not applicable
------------------------	----------------

Section 3 – Composition/Information on Ingredients

Lithium-ion Battery is a mixture.

Hazardous Ingredients (Chemical Name)	Concentration or concentration ranges (%)	CAS Number
Lithium Cobalt Oxide (CoLiO ₂)	41	12190-79-3
Graphite	10	7782-42-5
Phosphate(1-), hexafluoro-, lithium	10	21324-40-3
Aluminum Foils	15	7429-90-5
Copper	10	7440-50-8
1,1-Difluoroethylene polymer	1	24937-79-9
Dimethyl carbonate	5	616-38-6
Ethylene carbonate	5	96-49-1
Nickel	3	7440-02-0

Note: CAS number is Chemical Abstract Service Registry Number.

N/A=Not apply.

(*)Main ingredients: Lithium hexafluorophosphate, organic carbonates

Section 4 – First-aid Measures

Inhalation	If contents of an opened battery are inhaled, remove source of contamination or move victim to fresh air. Obtain medical advice.
Skin contact	If skin contact with contents of an open battery occurs, as quickly as possible remove contaminated clothing, shoes and leather goods. Immediately flush with lukewarm, gently flowing water for at least 30 minutes. If irritation or pain persists, seek medical attention. Completely decontaminate clothing, shoes and leather goods before reuse or discard.
Eye contact	If eye contact with contents of an open battery occurs, immediately flush the contaminated eye(s) with lukewarm, gently flowing water for at least 30 minutes while holding the eyelids open. Neutral saline solution may be used as soon as it is available. If necessary, continue flushing during transport to emergency care facility. Take care not to rinse contaminated water into the unaffected eye or onto face. Quickly transport victim to an emergency care facility.
Ingestion	If ingestion of contents of an open battery occurs, never give anything by mouth if victim



	is rapidly losing consciousness, or is unconscious or convulsing. Have victim rinse mouth thoroughly with water. DO NOT INDUCE VOMITING. Have victim drink 60 to 240 mL (2-8 oz.) of water. If vomiting occurs naturally, have victim lean forward to reduce risk of aspiration. Have victim rinse mouth with water again. Quickly transport victim to an emergency care facility.
--	---

Section 5 – Fire-fighting Measures

Flammable Properties	In the event that this battery has been ruptured, the electrolyte solution contain within the battery would be flammable. Like any sealed container, battery cells may rupture when exposed to excessive heat; this could result in the release of flammable or corrosive materials.
Suitable extinguishing Media	Use extinguishing media suitable for the materials that are burning.
Unsuitable extinguishing Media	Not available
Explosion Data	Sensitivity to Mechanical Impact: This may result in rupture in extreme cases Sensitivity to Static Discharge: Not Applicable
Specific Hazards arising from the chemical	Fires involving Lithium-ion Battery was controlled with water. When water is used, however, hydrogen gas may evolve. In a confined space, hydrogen gas can form an explosive mixture. In this situation, smothering agents are recommended to extinguish the fire
Protective Equipment and precautions for firefighters	As for any fire, evacuate the area and fight the fire from a safe distance. Wear a pressure-demand, self-contained breathing apparatus and full protective gear. Fight fire from a protected location or a safe distance. Use NIOSH/MSHA approved full-face self-contained breathing apparatus (SCBA) with full protective gear.
NFPA	Health: 0 Flammability: 0 Instability: 0

Section 6 – Accidental Release Measures

Personal Precautions, protective equipment, and emergency procedures	Restrict access to area until completion of clean-up. Do not touch the spilled material. Wear adequate personal protective equipment as indicated in Section 8.
Environmental Precautions	Prevent material from contaminating soil and from entering sewers or waterways.
Methods and materials for Containment	Stop the leak if safe to do so. Contain the spilled liquid with dry sand or earth. Clean up spills immediately.



Methods and materials for cleaning up	Absorb spilled material with an inert absorbent (dry sand or earth). Scoop contaminated absorbent into an acceptable waste container. Collect all contaminated absorbent and dispose of according to directions in Section 13. Scrub the area with detergent and water; collect all contaminated wash water for proper disposal.
---------------------------------------	--

Section 7 – Handling and Storage

Handling	<p>Do not dismantle, open or shred secondary Lithium-ion Battery;</p> <p>Don't handling Polymer Li-ion Battery with metalwork. Do not open, disassemble, crush or burn battery. Ensure good ventilation/ exhaustion at the workplace.</p> <p>Prevent formation of dust.</p> <p>Information about protection against explosions and fires: Keep ignition sources away- Do not smoke.</p>
Storage	<p>If the Lithium-ion Battery is subject to storage for such a long term as more than 3 months, it is recommended to recharge the Lithium-ion Battery periodically.</p> <p>3 months: -10°C~+40°C, 45 to 85%RH</p> <p>And recommended at -20°C~+25°C for long period storage.</p> <p>The capacity recovery rate in the delivery state (50% capacity of fully charged) after storage is assumed to be 80% or more.</p> <p>The voltage for a long time storage shall be 3.7V~4.0V range.</p> <p>Do not storage Lithium-ion Battery haphazardly in a box or drawer where they may short-circuit each other or be short-circuited by other metal objects.</p> <p>Keep out of reach of children.</p> <p>Do not expose Lithium-ion Battery to heat or fire. Avoid storage in direct sunlight.</p> <p>Do not store together with oxidizing and acidic materials.</p>

Section 8 – Exposure Controls and Personal Protection

Engineering Controls	Use local exhaust ventilation or other engineering controls to control sources of dust, mist, fumes and vapor.
----------------------	--



	Keep away from heat and open flame. Store in a cool, dry place.
Personal Protective Equipment	<p>Respiratory Protection: Not necessary under normal conditions.</p> <p>Skin and body Protection: Not necessary under normal conditions, Wear neoprene or nitrile rubber gloves if handling an open or leaking battery.</p> <p>Hand protection: Wear neoprene or natural rubber material gloves if handling an open or leaking battery.</p> <p>Eye Protection: Not necessary under normal conditions, Wear safety glasses if handling an open or leaking battery.</p>
Other Protective Equipment	Have a safety shower and eye wash fountain readily available in the immediate work area.
Hygiene Measures	Do not eat, drink, or smoke in work area. Maintain good housekeeping.

Section 9 - Physical and Chemical Properties

Physical State	Form: Solid
	Color: Silvery white
	Odour: Monotony
Change in condition:	
pH, with indication of the concentration	Not applicable
Melting point/freezing point	Not available.
Boiling Point, initial boiling point and Boiling range:	Not available.
Flash Point	Not available.
Upper/lower flammability or explosive limits	Not available.
Vapor Pressure:	Not applicable
Vapor Density: (Air = 1)	Not applicable
Density/relative density	Not available.
Solubility in Water:	Insoluble
n-octanol/water partition coefficient	Not available.
Auto-ignition temperature	130°C
Decomposition temperature	Not available.
Odour threshold	Not available.



Evaporation rate	Not available.
Flammability (soil, gas)	Not available.
Viscosity	Not applicable

Section 10 - Stability and Reactivity

Stability	The product is stable under normal conditions.
Conditions to Avoid (e.g. static discharge, shock or vibration)	Do not subject Lithium-ion Battery to mechanical shock. Vibration encountered during transportation does not cause leakage, fire or explosion. Do not disassemble, crush, short or install with incorrect polarity. Avoid mechanical or electrical abuse.
Incompatible Materials	Not Available
Hazardous Decomposition Products	This material may release toxic fumes if burned or exposed to fire
Possibility of Hazardous Reaction	Not Available

Section 11 - Toxicological Information

In normal condition, contact with the battery is non-toxic.

Section 12 - Ecological Information

General note:	Water hazard class 1(Self-assessment): slightly hazardous for water. Do not allow undiluted product or large quantities of it to reach ground water, water course or sewage system.
Anticipated behavior of a chemical product in environment/possible environmental impact/ecotoxicity	Not Available
Mobility in soil	Not Available
Persistence and Degradability	Not Available
Bioaccumulation potential	Not Available
Other Adverse Effects	Not Available

Section 13 – Disposal Considerations



Product disposal recommendation: Observe local, state and federal laws and regulations.

Packaging disposal recommendation: Be aware discarded batteries may cause fire, tape the battery terminals to insulate them. Don't disassembly the battery. Completely discharge containers (no tear drops, no powder rest, scraped carefully). Containers may be recycled or re-used. Observe local, state and federal laws and regulations.

The potential effects on the environment and human health of the substances used in batteries and accumulators; the desirability of not disposing of waste batteries and accumulators as unsorted municipal waste and of participating in their separate collection so as to facilitate treatment and recycling;

Section 14 – Transport Information

This report applies to by sea, by air and by land;

The **Lithium-ion Battery** according to Section II of PACKING INSTRUCTION 965-967 of the 2015 IATA Dangerous Goods regulations 56th Edition may be transported. and applicable U.S. DOT regulations for the safe transport of Lithium-ion Battery.

Polymer Li-ion Battery was protected so as to prevent short circuits. This includes protection against contact with conductive materials within the same packaging that could lead to short circuit;

Cell and batteries offered for transport must be packed in inner packaging's that completely enclose the cell or battery; to provide protection from damage or compression to the batteries, the inner packaging's must be placed in a strong rigid outer packaging;

The packaging shall be adequate to avoid mechanical damage during transport, handling and stacking. The materials and pack design shall be chosen so as to prevent the development of unintentional electrical conduction, corrosion of the terminals and ingress of moisture.

The package must be handled with care and that a flammability hazard exists if the package is damaged;

With regard to transport, the following regulations are cited and considered:

- The International Civil Aviation Organization (ICAO) Technical Instructions.
- The International Air transport Association (IATA) Dangerous Goods Regulations.

UN number of lithium battery: UN3480;

UN Proper shipping name/Description (technical name): Lithium ion batteries;

Marine pollutant(Y/N): N;

- The International Maritime Dangerous Goods (IMDG) Code (2012 Edition).

For lithium-ion batteries by sea, provided that packaging is strong and prevent the products from short-circuit.

UN number of lithium battery: UN3481;

UN Proper shipping name/Description (technical name): Lithium ion batteries

Marine pollutant(Y/N): Y;

Special Provision: International maritime dangerous goods code (IMDG) 188, 230, 310, 348, 957;

- The US Hazardous Materials Regulation (HMR) pursuant to a final rule issued by RSPA
- The Office of Hazardous Materials Safety within the US Department of Transportations' (DOT) Research and Special Programs Administration (RSPA)



Section 15 - Regulatory Information

OSHA hazard communication standard (29 CFR 1910.1200)

Hazardous Non-hazardous

Section 16 - Other Information

The information above is believed to be accurate and represents the best information currently available to us. However, concorde makes no warranty of merchantability or any other warranty, express or implied, with respect to such information, and we assume no liability resulting from its use. Users should make their own investigations to determine the suitability of the information for their particular purposes. Although reasonable precautions have been taken in the preparation of the data contained herein, it is offered solely for your information, consideration and investigation. This material safety data sheet provides guidelines for the safe handling and use of this product; it does not and cannot advise on all possible situations, therefore, your specific use of this product should be evaluated to determine if additional precautions are required.

The data/information contained herein has been reviewed and approved for general release on the basis that this document contains no export controlled information.

*****The End*****

聚合物锂离子电池规格书

LITHIUM-POLYMER (LIPO) BATTERY SPECIFICATIONS

Battery Type: GLP503450 1000mAh 3.7V

电池型号: GLP503450 1000mAh 3.7V

	Signature 签名	Date 日期
Prepared 编制	Wang Li	2015-02-06
Checked 审核	Guo Dongle Ming	2015-02-06
Approved 批准		
Confirmed 客户确认		

Content

目录

1.Scope	3
适用范围	
2.Model:GLP503450	3
型号: GLP503450	
3.Specification	3
产品规格	
4.Battery PACK Performance Criteria.....	3-5
电池性能检查及测试	
5.Storage and Others	5
贮存及其它事项	
6. Protection Circuit Characteristics.....	6
保护电路特性	
7. Pack Drawing	7
组装图	
Handling Precautions and Guideline	8
聚合物锂离子充电电芯操作指示及注意事项	
1.Charging	8-9
充电	
2.Discharging	9-10
放电	
3.Storage	10
贮存	
4.Handling of Cells	10-11
电池操作注意事项	
5.Notice for Designing Battery Pack	11
电池外壳设计注意事项	
6.Notice for Assembling Battery Pack	11
电池与外壳组装注意事项	
7.Others	11-12
其它事项	

1. Scope

This document describes the Product Specification of the Lithium-Polymer (LIP) rechargeable battery cell.

适用范围

本规格说明书描述了可充电聚合物锂离子电池的产品性能指标

2. Model: GLP503450 1000mAh 3.7V

型号: GLP503450 1000mAh 3.7V

3. Specification

产品规格

NO.	Items	Specifications
1	Charge voltage 充电电压	4.2V
2	Nominal voltage 标称电压	3.7V
3	Nominal capacity 标称容量	1000mAh @ 0.2C Discharge(放电)
4	Charge current 充电电流	Standard Charging: 0.5C 标准充电: 0.5C Rapid charge: 1.0C 快速充电: 1.0C
5	Standard Charging method 标准充电方法	0.5C CC (constant current) charge to 4.2V, then CV (constant voltage 4.2V) charge till charge current decline to $\leq 0.05C$ 0.5C CC (恒流) 充电至 4.2V, 再 CV (恒压 4.2V) 充电直至充电电流 $\leq 0.05C$
6	Charging time 充电时间	Standard Charging: 3.0 hours (Ref.) 标准充电: 3.0 小时 (参考值) Rapid charge: 2 hours (Ref.) 快速充电: 1.2 小时 (参考值)
7	Max. charge current 最大充电电流	1.0C (1000mAh)
8	Max. discharge current 最大放电电流	2.0C (2000mAh)
9	Discharge cut-off voltage 放电截止电压	3.0V
10	Operating temperature 工作温度	Charging: 0°C~40°C 充电: 0°C~40°C Discharging: -10°C~50°C 放电: -10°C~50°C
11	Storage temperature 储存温度	-10°C~+45°C
12	PACK Weight 电池重量	Approx: 19.0 g 约: 19.0g

4. Battery PACK Performance Criteria

电池性能检查及测试

4.1 Electrical characteristics 充放电性能

NO.	Items	Test Method and Condition	Criteria
1	Standard Charge 标准充电	Charging the cell initially with constant current at 0.5C to 4.2V and then with constant voltage at 4.2V till charge current declines to 0.05C 先用 0.5C 恒流充电至 4.2V, 再恒压 4.2V 充电直至充电电流 $\leq 0.05C$	
2	Rated Capacity 初始容量	The capacity means the discharge capacity of the cell, which is measured with discharge current of 0.2C with 3.0V cut-off voltage after standard charge. 该容量是指标准充电后, 0.2C 放电至 3.0V 截止电压所放出的容量。	$\geq 1000mAh$
3	Cycle Life 循环寿命	IEC62133:2002	≥ 500 cycles
4	Self-discharge 自放电	After the standard charging, storied the cells under the condition as No.4.4 for 30 days, then measured the capacity with 0.2C till 3.0V 标准充电后, 在 No.4.4 条件下贮存 30 天, 再以 0.2C 放电至 3.0V 所放出的容量。	Residual capacity >90% 剩余容量 >90%
5	Initial impedance 初始内阻	Internal resistance measured at AC 1KHz after 50% charge 半充状态下, 测量其 AC 1KHz 下的交流阻抗	$\leq 120m\Omega$
6	PACK Voltage 电池电压	As of shipment. 出货状态	3.6V~3.9V
7	Temperature Characteristics 温度特性	1. According to item 4.1.1, at $23 \pm 5^\circ C$. 2. Capacity comparison at each temperature, measured with constant discharge current 0.2C with 3.0V cut-off. Percentage as an index of the capacity compared with 100% at $23^\circ C$ 1. 在 $23 \pm 5^\circ C$ 条件下, 用 4.1.1 方法将电芯充电。 2. 在不同温度条件下, 用 0.2C 的电流恒流放电至截止电压 3.0V。以 $23^\circ C$ 时放电容量为基准计算百分比。	$-20^\circ C$: $\geq 65\%$ $23^\circ C$: 100% $60^\circ C$: $\geq 90\%$
8	Storage Characteristics 储存特性	1. According to item 4.1.1, at $23 \pm 5^\circ C$. 2. The battery shall be stored at $80 \pm 5^\circ C$ for 4 hours (measure thickness) and rested at room temperature for 1 hour then measured with constant discharge current 0.2C with 3.0V cut-off. (measure Capacity) 1. 在 $23 \pm 5^\circ C$ 条件下, 用 4.1.1 方法将电芯充电。 2. 将电池在 $80 \pm 5^\circ C$ 条件下贮存 4 小时, 然后在常温下静置 2 小时, 用 0.2C 的电流恒流放电至 3.0V 截止电压。	Retained Capacity $\geq 95\%$ Retained Thickness $\leq 10\%$

4.2 Mechanical characteristics

机械特性

NO.	Items	Test Method and Condition	Criteria
1	Vibration Test 振动测试	After standard charging, fixed the cell to vibration table and subjected to vibration cycling that the frequency is to be varied at the rate of 1Hz per minute between 10Hz an 55Hz,the excursion of the vibration is 1.6mm.The cell shall be vibrated for 30 minutes per axis of XYZ axes. 将标准充电后的电池固定在振动台上，沿 X、Y、Z 三个方向各振动 30 分钟，振幅 1.6 mm，振动频率为 10Hz~55Hz，每分钟变化为 1Hz。	No leakage 无泄漏 No fire 不起火
2	Drop Test 跌落测试	The cell is to be dropped from a height of meter twice onto concrete ground. 将标准充电后的电池从 1 米高度跌落至混凝土地面 2 次	No fire, no leakage. 无起火、无泄漏

4.3 Visual inspection

There shall be no such defect as scratch, flaw, crack, and leakage, which may adversely affect commercial value of the cell.

外观检查

不允许有任何影响电池性能的外观缺陷，诸如裂纹、裂缝、泄漏等。

4.4 Standard environmental test condition

Unless otherwise specified, all tests stated in this Product Specification are conducted at below condition:

Temperature: $23 \pm 5^{\circ}\text{C}$

Humidity: $65 \pm 20\% \text{RH}$

标准测试环境

除非特别说明，本标准书中所有测试均在以下环境条件下进行：

温度： $23 \pm 5^{\circ}\text{C}$

湿度： $65 \pm 20\% \text{RH}$

5.Storage and Others

贮存及其它事项

a) Long Time Storage

If the Cell is stored for a long time, the cell's storage should be 3.6~3.9V and the cell is to be stored in a condition as No.4.4.

长期贮存

长期贮存的电池（超过 3 个月）须置于干燥、凉爽处。贮存电压为 3.6~3.9V 且贮存环境要求如 4.4。

b) Others

Any matters that this specification does not cover should be conferred between the customer

其它事项

任何本说明书中未提及的事项，须经双方协商确定

6. Protection Circuit Characteristics (at 25°C)--This specification item is option.
 6.1 Electrical Characteristic

Item	Symbol	Content	Criterion
Over charge Protection	V_{DET1}	Over charge detection voltage	4.28±0.05V
	$t_{V_{DET1}}$	Over charge detection delay time	250±75ms
Over discharge protection	V_{DET2}	Over discharge detection voltage	3.0±0.1V
	$t_{V_{DET2}}$	Over discharge detection delay time	20ms~26ms
Over current protection	V_{DET3}	Over current detection voltage	65-95mv
	I_{DP}	Over current detection current	1.2A~2.8A
	$t_{V_{DET3}}$	Detection delay time	8ms~16ms
		Release condition	Cut load
Short protection		Detection condition	Exterior short circuit
	T_{SHORT}	Detection delay time	250-500u
		Release condition	Cut short circuit
Interior re-sistance	R_{DS}	Main loop electrify resistance	$V_C=3.7V$; $R_{DS} \leq 70m\Omega$
Current consumption	I_{DD}	Current consume in normal operation	0.2μA Type 7μA Max

6.2 PCB Pad description

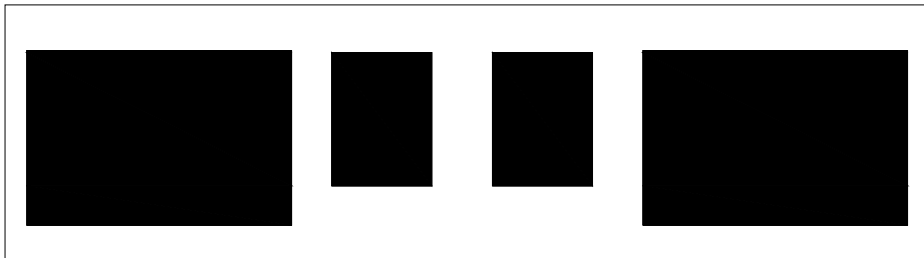

6.3 Application Circuit

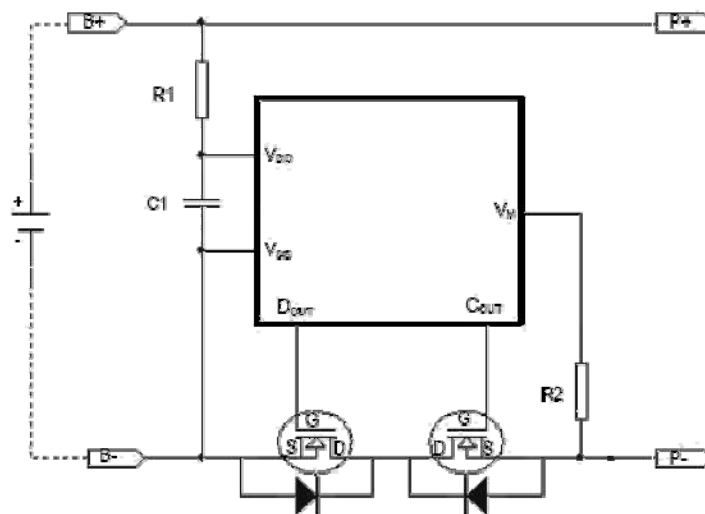

7.Pack Drawing

7.1 Soft pack drawing (Product Outer Dimension: MAX5.8 (T) × 41(W) × 62.0(L) mm)

51021-3P (红、白、黑)

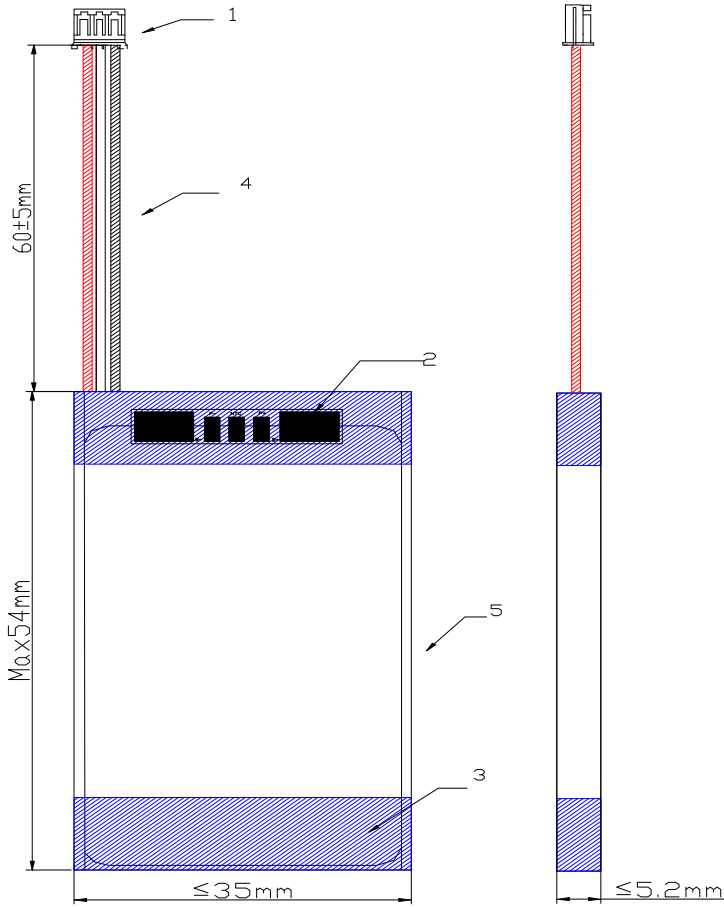

7.2 BOM of Product

	Item	Model	Specification	Remarks
1	Plugs	51021-3P	Red: +、White: 10K NTC、Black: -	1
2	PCM	Li-ion single cell PCM	Over Voltage Protect: 4.28±0.035V Over Discharge Protect: 3.0±0.08V NTC:10K	1
3	Tape	Kapton	See figure	
4	Wire		AWG1571 26#, 线长 60 mm	3

5	Cell	P503450-1C	1000mAh	1
---	------	------------	---------	---

Appendix

附录

Handling Precautions and Guideline For LIP(Lithium-Ion Polymer)Rechargeable Batteries

聚合物锂离子充电电池操作指示及注意事项

Preface

This document of Handling Precautions and Guideline LIP Rechargeable Batteries shall be applied to the battery cells manufactured.

前言

本文件“聚合物锂离子充电电池操作指示及注意事项”仅适用于聚合物电池。

Note(1):

The customer is requested to contact factory in advance, if and when the customer needs other applications or operating conditions than those described in this document. Additional experimentation may be required to verify performance and safety under such conditions.

声明一:

客户若需要将电池用于超出文件规定以外的设备，或在文件规定以外的使用条件下使用电池，应事先联系工厂，因为需要进行特定的实验测试以核实电池在该使用条件下的性能及安全性。

Note(2):

Factory will take no responsibility for any accident when the cell is used under other conditions than those described in this Document.

声明二:

对于在超出文件规定以外的条件下使用电池而造成的任何意外事故，工厂概不负责。

Note(3):

Factory will inform, in a written form, the customer of improvement(s) regarding proper use and handing of the cell, if it is deemed necessary.

声明三:

如有必要，工厂会以书面形式告之客户有关正确操作使用电池的改进措施。

1. Charging

充电

1.1 Charging current:

Charging current should be less than maximum charge current specified in the Product Specification. Charging with higher current than recommended value may cause damage to cell electrical, mechanical and safety performance and could lead to heat generation or leakage.

充电电流

充电电流不得超过本标准书中规定的最大充电电流。使用高于推荐值电流充电将可能引起电池的充放

电性能、机械性能和安全性能的问题，并可能会导致发热或泄漏。

1.2 Charging voltage:

Charging shall be done by voltage less than that specified in the Product Specification (4.2V/cell). Charging beyond 4.25V, which is the absolute maximum voltage, must be strictly prohibited. The charger shall be designed to comply with this condition.

It is very dangerous that charging with higher voltage than maximum voltage may cause damage to the cell electrical, mechanical safety performance and could lead to heat generation or leakage.

充电电压

充电电压不得超过本标准书中规定的额定电压（4.2V/电芯）。4.25V 为充电电压最高极限，充电器的设计应满足此条件。

电芯电压高于额定电压值时，将可能引起电池的充放电性能、机械性能和安全性能的问题，可能会导致发热或泄漏。

1.3 Charging temperature:

The cell shall be charged within 0°C~60°C range in the Product Specification.

充电温度

电池必须在 0°C~60°C 的环境温度范围内进行充电。

1.4 Prohibition of reverse charging:

Reverse charging is prohibited. The cell shall be connected correctly. The polarity has to be confirmed before wiring. In case of the cell is connected improperly, the cell cannot be charged. Simultaneously, the reverse charging may cause damaging to the cell which may lead to degradation of cell performance and damage the cell safety, and could cause heat generation or leakage.

禁止反向充电

正确连接电池的正负极，严禁反向充电。若电池正负极接反，将无法对电池进行充电。同时，反向充电会降低电池的充放电性能、安全性，并会导致发热、泄漏。

2. Discharging

放电

2.1 Discharging current

The cell shall be discharged at less than the maximum discharge current specified in the Product Specification. High discharging current may reduce the discharging capacity significantly or cause over-heat.

放电电流

放电电流不得超过本标准书规定的最大放电电流，大电流放电会导致电池容量剧减并导致过热。

2.2 Discharging temperature

The cell shall be discharged within -20°C~60°C range specified in the Product Specification.

电池必须在-20°C~60°C 的环境温度范围内进行放电。

2.3 Over-discharging:

It should be noted that the cell would be at over-discharged state by its self-discharge characteristics in case the cell is not used for long time. In order to prevent over-discharging, the cell shall be charged periodically to maintain between

3.6V and 3.9V.

Over-discharging may causes loss of cell performance, characteristics, or battery functions.

The charger shall be equipped with a device to prevent further discharging exceeding a cut-off voyage specified in the Product Specification. Also the charger shall be equipped with a device to control the recharging procedures as follows:

The cell battery pack shall start with a low current (0.01C) for 15-30 minutes, i.e.-charging, before rapid charging starts. The rapid charging shall be started after the (individual) cell voltage has been reached above 3V within 15-30 minutes that can be determined with the use of an appropriate timer for pre-charging. In case the (individual) cell voltage does not rise to 3V within the pre-charging time, then the charger shall have functions to stop further charging and display the cell/pack is at abnormal state.

过放电需要注意的是，在电池长期未使用期间，它可能会用其它自放电特性而处于某种过放电状态。为防止放电的发生，电池应定期充电，将其电压维持在 3.6V 至 3.9V 之间。

过放电会导致电池性能、电池功能的丧失。

充电器应有装置来防止电池放电至低于本标准书规定的截止电压。此外，充电器还应有装置以防止重复充电，步骤如下：

电池在快速充电之前，应先以一小电流（0.01C）预充电 15~30 分钟，以使（每个）电芯的电压达到 3V 以上，再进行快速充电。可用一计时器来实现该预充电步骤。如果在预充电规定时间内，（个别）电池的电压仍未升到 3.0V 以上，充电器应能够停止下一步快速充电，并显示该/电池正处于非正常状态。

3. Storage

贮存

The cell shall be storied within $-10^{\circ}\text{C}\sim 60^{\circ}\text{C}$ range environmental condition.

If the cell has to be storied for a long time (Over 3 months),the environmental condition should be:

Temperature: $23\pm 5^{\circ}\text{C}$

Humidity: $65\pm 20\%\text{RH}$

The voltage for a long time storage shall be 3.6V~3.9V range.

电池储存温度必须在 $-10^{\circ}\text{C}\sim 60^{\circ}\text{C}$ 的范围内。

长期存储电池（超过 3 个月）须置于温度为 $23\pm 5^{\circ}\text{C}$ 、湿度为 $65\pm 20\%\text{RH}$ 的环境中。

贮存电压为 3.6V~3.9V

4. Handling of Cells

电池操作注意事项

Since the battery is packed in soft package, to ensure its better performance, it's very important to carefully handle the battery

由于电池属于软包装，为保证电池的性能不受损害，必须小心对电池进行操作。

4.1 Soft Aluminum foil

The soft aluminum packing foil is very easily damaged by sharp edge parts such as Ni-tabs, pins and needles.

- Don't strike battery with any sharp edge parts
- Trim your nail or wear glove before taking battery
- Clean worktable to make sure no any sharp particle

铝箔包装材料易被尖锐部件损伤，诸如镍片，尖针。

- 禁止用尖锐部件碰撞电池;
- 取放电池时, 请修短指甲或戴上手套;
- 应清洁工作环境, 避免有尖锐物体存在

4.2 Folding edge

The folding edge is form in battery process and passed all hermetic test

- Don't open or deform folding edge
折边
折边在电池生产过程中已完成, 并通过了密封测试。
- 禁止打开或破坏折边。

4.3 Mechanical shock

- Don't Fall, hit, bend battery body
机械撞击
- 禁止坠落、冲击、弯折电池。

5. Notice Designing Battery Pack

电池外壳设计注意事项

5.1 Pack design

- Battery pack should have sufficient strength and battery should be protected from mechanical shock
- No Sharp edge components should be inside the pack containing the battery.
外壳设计
- 电池外壳应有足够的机械强度以保证其内部电芯免受机械撞击。
- 外壳内安装电芯的部位不应有锋利的边角。

6. Notice for Assembling Battery Pack

电池与外壳组装注意事项

6.1 Cell fixing

- The battery should be fixed to the battery pack by its large surface area.
- No cell movement in the battery pack should be allowed.

电池的安装

- 应将电芯的宽面安装在外壳内;
- 电池不得在壳内活动。

7. Others

其它事项

7.1 Prevention of short circuit within a battery pack

Enough insulation layers between wiring and the cells shall be used to maintain extra safety protection.

7.2 Prohibition of disassembly

严禁拆卸电池

1) Never disassemble the cells

The disassembling may generate internal short circuit in the cell, which may cause gassing, firing, or other problems.

在任何情况下不得拆卸电池, 拆卸电池可能会导致内部短路, 进而引起鼓气、着火及其它问题。

2) Electrolyte is harmful

LIP battery should not have liquid from electrolyte flowing, but in case the electrolyte come into contact with the skin, or eyes, physicians shall flush the electrolyte immediately with fresh water and medical advice is to be

sought.

电解液有害，聚合物锂电池理论上不存在流动的电解液，但万一有电解液泄漏而接触到皮肤、眼睛或身体其它部位，应立即用清水冲洗电解液并就医。

7.3 Prohibition of dumping of cells into fire

Never incinerate nor dispose the cells in fire. These may cause firing of the cells, which is very dangerous and is prohibited.

严禁将电池投入火中，在任何情况下，不得燃烧电池或将电池投入火中，否则会引起电芯燃烧，这是非常危险的，应绝对禁止。

7.4 Prohibition of cells immersion into liquid such as water

The cells shall never be soaked with liquids such as water, seawater drinks such as soft drinks, juices coffee or others.

严禁将电池浸入液体，如水

不得将电池浸泡液体，如淡水、海水、饮料（果汁、咖啡等）。

7.5 Battery cells replacement

The battery replacement shall be done only by either cells supplier or device supplier and never be done by the user.

电芯的更换

更换电芯应由电芯供应商或设备供应商完成，用户不得自行更换。

7.6 Prohibition of use of damaged cells

The cells might be damaged during shipping by shock. If any abnormal features of the cells are found such as damages in a plastic envelop of the cell, deformation of the cell package, smelling of electrolyte, electrolyte leakage and others, the cells shall never be used any more.

The cells with a smell of the electrolyte or a leakage shall be placed away from fire to avoid firing.

禁止使用已损坏的电池

电池在运输过程中可能因撞击等原因而损坏，若发现电池有任何异常特征，如电池塑料封边损坏，外壳破损，闻到电解液气体，电解液泄漏等，该电池不得使用。有电解液泄漏或散发电解液气味的电池应远离火源以避免着火。