



MAXX COLD X-series

Project Name:	
Location:	
Item:	Qty:
Model:	

SANDWICH UNITS

- ▶ MXCR-29S
- ▶ MXCR-48S
- ▶ MXCR-60S



MXCR-29S



MXCR-48S





MXCR-60S

FEATURES

Maxx Cold X-Series Sandwich Stations provide the perfect blend of durability and accessibility to allow for quick and easy preparation of sandwiches, salads, and more at a value price. A high quality stainless steel exterior allows for easy cleaning and a heavy duty stainless steel insulated hood keeps products cool and fresh.

- Stainless steel exterior and coated aluminum interior
- CFC Free Polyurethane insulated walls and doors
- Standard recessed door handles
- Adjustable, heavy-duty wire shelves, each unit comes with one per section/door
- Four casters (2 locking, 2 non-locking)
- Uses R-134a refrigerant
- Forced-air refrigeration
- Efficient self contained cooling system
- Available in 120V/60Hz, 220V/50Hz, and 220V/60Hz

 	Specifications subject to change without notice.
	Approvals: UL, UL sanitation



MAXX COLD X-series

SANDWICH UNITS

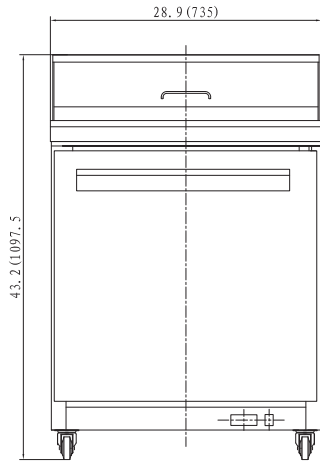

MXCR-29S

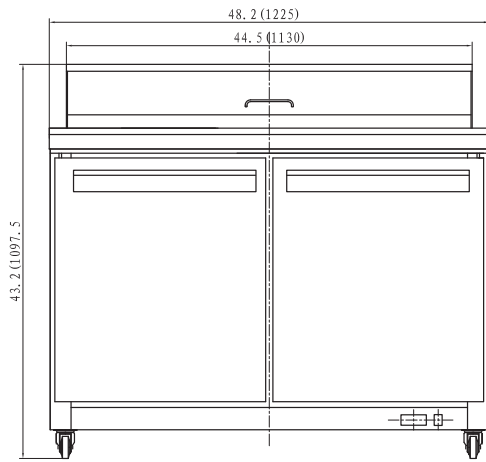

MXCR-48S

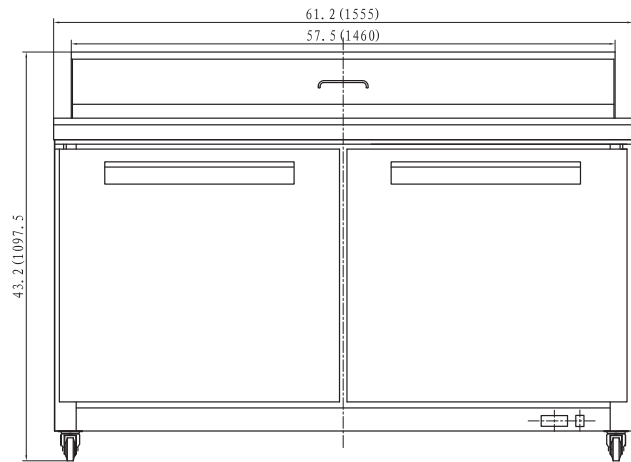

MXCR-60S

SPECIFICATIONS

Model	Dim (W"xD"xH")	Capacity	Temp	Watts	Doors	Weight	Pans (1/6)
MXCR-29S	28.9 x 30 x 43.2 (734x762x1097.3mm)	7 Cu Ft 198 L	28° to 39°F -2°C to 4°C	575	1	276 lb 125 kg	8
MXCR-48S	48.2 x 30 x 43.2 (1224x762x1097.3mm)	12 Cu Ft 340 L	28° to 39°F -2°C to 4°C	805	2	313 lb 142 kg	12
MXCR-60S	61.2 x 30 x 43.2 (1555x762x1097.3mm)	15.5 Cu Ft 439 L	28° to 39°F -2°C to 4°C	862	2	362 lb 164 kg	16

MAXX COLD

3355 Enterprise Avenue - Fort Lauderdale - FL 33331 - Tel: 954.202.7419

www.thelegacycompanies.com