

Owner's Manual contains:  
Installation, operating,  
maintenance & warranty  
instructions.

## Synergy 260, 270



Marantec America Corporation  
5705 Centerpoint Court, Gurnee, IL 60031 U.S.A.  
Phone 1-888-622-2489 • Fax 847-478-0348

[www.marantecamerica.com](http://www.marantecamerica.com)

## OWNER'S MANUAL CONTENTS

1.	INTRODUCTION	3
2.	ADVANCED FEATURES	3
3.	IMPORTANT SAFETY INFORMATION	3
4.	TOOLS	4
5.	GARAGE	4
6.	OPERATOR PACKAGE CONTENTS	6
7.	IMPORTANT INSTALLATION INSTRUCTIONS	7
8.	INSTALLATION STEPS	8
8-1.	MEASURE AND MARK DOOR AREA	8
8-2.	INSTALL HEADER BRACKET	8
8-3.	INSTALL DOOR BRACKET TO DOOR	9
8-4.	ATTACH RAIL TO OPERATOR HEAD	10
8-5.	ATTACH RAIL TO HEADER BRACKET	11
8-6.	POSITION OPERATOR FOR MOUNTING	11
8-7.	MOUNT OPERATOR TO CEILING	12
8-8.	CONNECT ARM TO DOOR AND TROLLEY	12
8-9.	RAIL BUMPER INSTALLATION	13
8-10.	CHECK EMERGENCY RELEASE	13
8-11.	INSTALL THE PHOTO EYE SENSOR SAFETY SYSTEM	14
8-12.	CONTROL PANEL	14
9.	CONTROL UNIT CONNECTIONS	15
10.	CONNECT TO POWER	16
11.	INITIAL SYSTEM SET UP	17
12.	ADVANCED SETTINGS	19
13.	TRANSMITTERS	23
14.	OPERATION OF YOUR OPERATOR	25
15.	HOMELINK® TRANSCEIVER	25
16.	TEST SAFETY REVERSAL	26
17.	ALIGN AND TEST PHOTO EYE SENSORS	26
18.	APPLY LABELS TO INSIDE OF GARAGE	27
19.	ATTACH OWNER'S MANUAL TO WALL	27
20.	IMPORTANT SAFETY INSTRUCTIONS	27
21.	TENSION ADJUSTMENT	28
22.	RAIL LENGTH ADJUSTMENT - FOR PROFESSIONAL INSTALLERS ONLY	28
23.	RAIL ASSEMBLY PARTS	29
24.	ACCESSORIES	30
25.	TROUBLESHOOTING - FOR PROFESSIONAL INSTALLERS ONLY	31
26.	MAINTENANCE AND ADJUSTMENTS	33
27.	LIMITED PARTS WARRANTY	33
28.	WARRANTY LIMITATIONS, CLAIMS AND SERVICE	35
29.	REGISTRATION	35
30.	WARRANTY SERVICE	35

## 1. INTRODUCTION

Congratulations on purchasing your Marantec® Synergy Garage Door Operator System, the most innovative operator available today. This stylishly designed digital operator with a wide range of accessories is engineered to provide the smoothest, quietest and safest operation to compliment any application. Advanced technology results in the operator being capable of easily moving almost any properly balanced sectional door, and at the same time providing state-of-the-art safety features to detect obstructions and to stop and reverse the door, thus helping to protect persons and property near the door.

## 2. ADVANCED FEATURES

This operator includes numerous state-of-the-art features to provide you, the user, with years of trouble-free, convenient, and safe use of your automatic garage door operator.

- **Advanced Digital Operating System EOS (Easy Operating System):** The EOS digital system provides an user friendly system set up. The system set up comprises of two programming levels, an "Initial Level" and an "Advanced Level". The EOS system requires only the initial set up parameters. All other operating parameters are learned and set automatically by the system. In addition, the system optimizes all parameters with every cycle for a more efficient operation by the GDO. This shorter parameter set up provides a quicker and more efficient installation.
- **New LED Lighting System:** Provides a green energy efficient lighting approach to conventional incandescent lighting. Added convenience requires no light bulb replacement.
- **Precision Controlled DC Motor, Complete with Automatic Soft Start and Soft Stop Feature:** The operator automatically detects when your door is almost fully closed or fully opened, and gradually slows the door down before it reaches its fully closed or opened position. During start-up, the door starts moving slowly and gradually ramps up to full speed for the full travel of your door. This reduces the possible damaging effects of the sudden starts and stops associated with some other operators, and results in the smooth operation and increased service life of your door and hardware.
- **Built-In Safety Features:** Including patented drive system that delivers only the optimum power needed to move your door safely - Every time!
- **Modular Antenna Concept (patented):** Plug-in your choice of frequency module.
- **Photo Eye (Infrared) Safety System:** State-of-the-art infrared beam system helps detect obstructions in the path of your door and automatically reverses closing door travel, helping to protect persons and property near the door.
- **Convenient Status Display:** To indicate the status of your door operator at any time. Especially useful if troubleshooting is necessary.
- **Numeric Parameter Display Setting:** Provides easier and quicker setup.
- **Numeric Error Code Display:** Provides quicker troubleshooting.
- **Quiet, Smooth Operation:** Precision engineering and carefully selected materials result in extremely smooth and quiet operation, unmatched by conventional garage door operators.
- **LCD Display System Control:** Easy navigation through levels and menus.
- **Maintenance and Service Scheduling:** Optimizes operator service life and trouble-free performance.
- **The EOS platform unifies all Marantec Products by design.**
- **Meets all UL 325 requirements.**

## 3. IMPORTANT SAFETY INFORMATION

This manual is essential to the safe and proper installation, operation, and maintenance of your operator. Read and follow all guidelines and operating instructions before the first use of this product. Store the manual in a safe, easily accessible location.

### **WARNING**

*Operate the garage door operator at 120V, 60Hz to avoid operator damage.*

*Garage doors are heavy, moving objects. When coupled with an automatic operator, electrical power is also present. If not properly installed, balanced, operated, and maintained, an automatic door can become dangerous and cause serious injury or death. Please pay close attention to the WARNING and CAUTION notices that appear throughout this manual. Failure to follow certain instructions may result in damage to the door or door opener, or may result in severe injury or death to yourself or others.*

#### **WARNING**

*WARNING means that severe injury or death could result from failure to follow instructions.*

**Mechanical**

#### **WARNING**

*WARNING means that severe injury or death could result from failure to follow instructions.*

**Electrical**

#### **CAUTION**

*CAUTION means that property damage or injury could result from failure to follow instructions.*

## 4. TOOLS

The instructions will refer to the tools shown below for proper installation, adjustment, and maintenance of the garage door operator. Additional tools may be required depending on your particular installation.

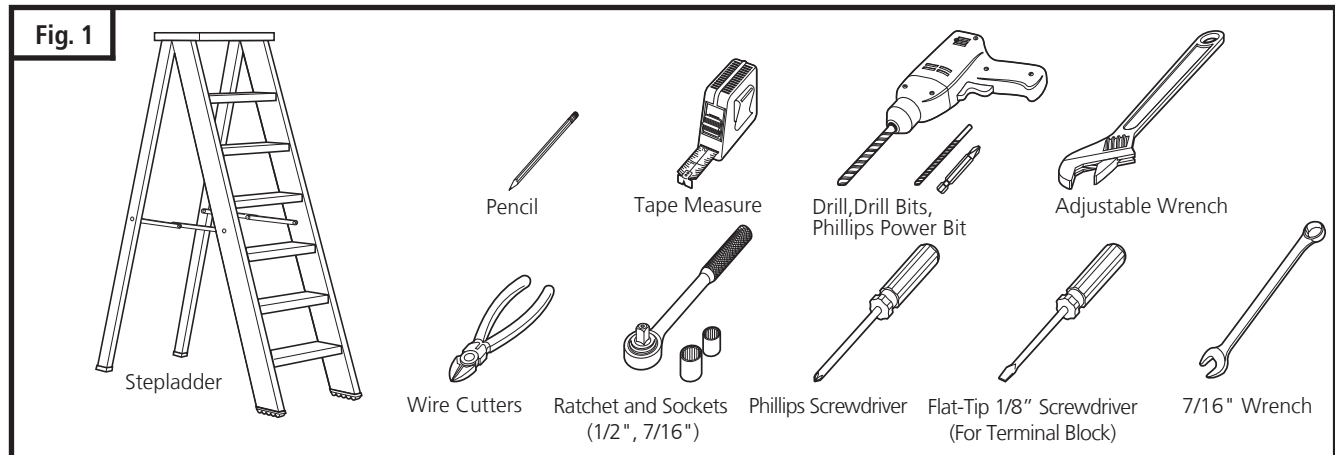

## 5. GARAGE

### ⚠ WARNING ⚠

*A garage door is a heavy moving object and can cause serious injury or death. An unbalanced door might not reverse when required, and can increase the risk of injury. If your garage door is out of balance, or if it binds or sticks, call for professional garage door service. Garage doors, springs, pulleys, cables, and hardware are under extreme tension and can cause serious injury or death.*

*Do not try to adjust them yourself. Ropes left on a garage door could cause someone to become entangled and could kill them. Remove all ropes connected to the door before installing your operator.*

Take a moment to survey your garage and garage door.

- Is there an access door besides the garage door? If not, you should install an emergency key release kit.
- With the garage door closed, check alignment of door and garage floor. The gap, if any, should be no more than 1/4". If the gap is larger than this, repair floor or door before installing operator.
- The operator is intended for installation on a properly balanced and adjusted garage door. **DO NOT INSTALL IF DOOR IS UNBALANCED OR BROKEN.**
- Check balance of door in mid travel and during full range of opening and closing. Lift the door about half way, as shown in Fig. 2 & 3. Release the door. It should remain in place, supported by its springs. Raise and lower the door fully to check for binding or sticking.
- If door is out of balance or needs repair, **DO NOT ADJUST IT YOURSELF. CALL A QUALIFIED GARAGE DOOR SERVICE PROFESSIONAL** to adjust your door.
- If your door is over 7 ft. high, you will need a longer rail. See section 6 "Rail Assembly" on p. 6 of this manual for availability of longer rails.

**Fig. 2**

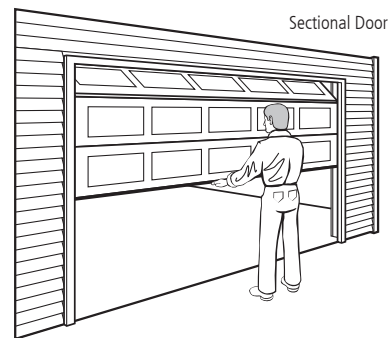

**Fig. 3**

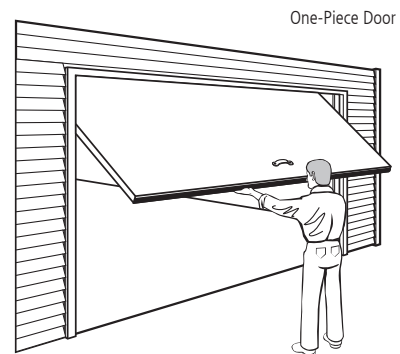

### ⚠ CAUTION ⚠

*To prevent damage to steel, aluminum, fiberglass or glass panel doors, always reinforce the inside of the door both vertically and horizontally with steel or angle iron bracing.*

*The best solution is to follow the instructions for your particular garage door or contact the garage door manufacturer for proper reinforcement instructions.*

## 5. GARAGE (cont'd)

Check the type of door construction you have. The information contained in the figures below will be referred to later in the manual for proper installation on the different door types.

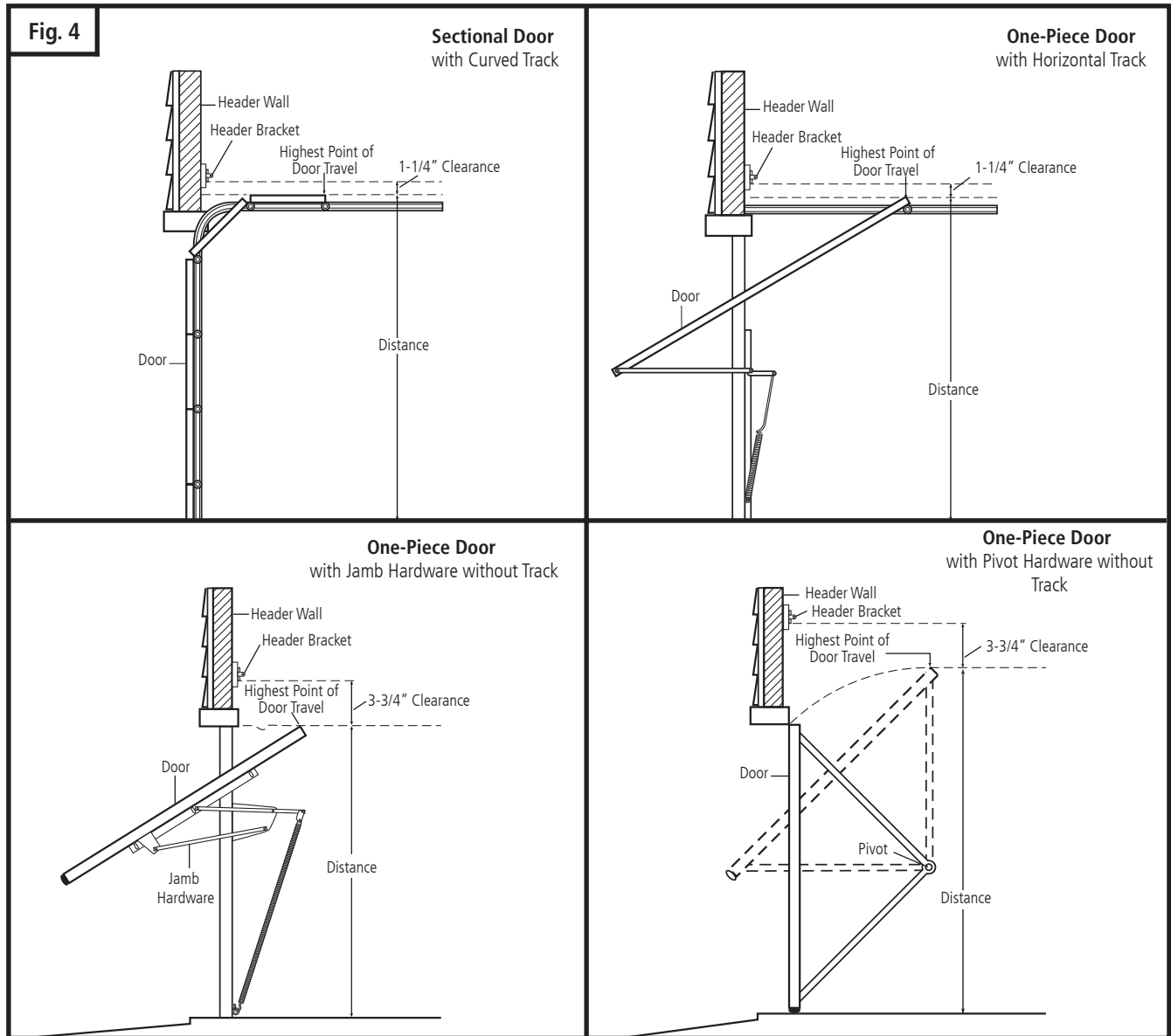

### GARAGE DOOR OPERATOR SYSTEM OVERALL DIMENSIONS (7' DOOR)

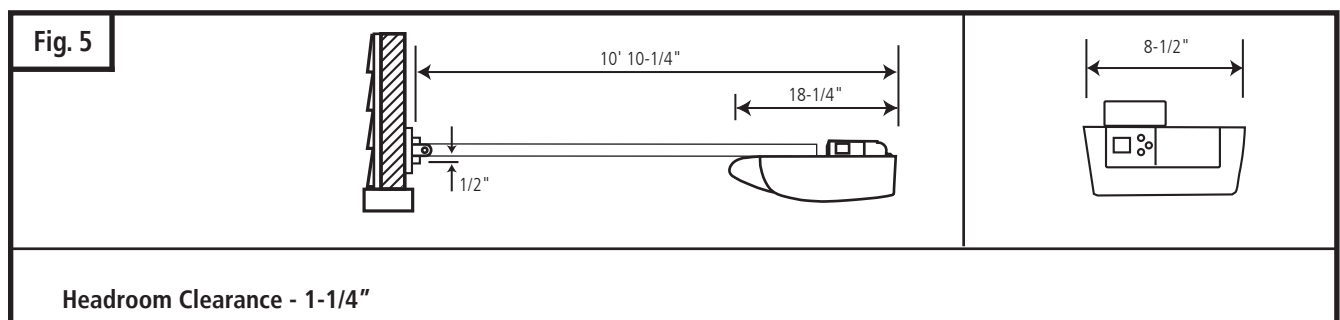

## 6. OPERATOR PACKAGE CONTENTS

The following items are included with your Garage Door Operator (GDO). All hardware components are located in the GDO carton. The accessories are packaged with their respective hardware in separate packs for ease of identification and use.

Items shown not actual size.

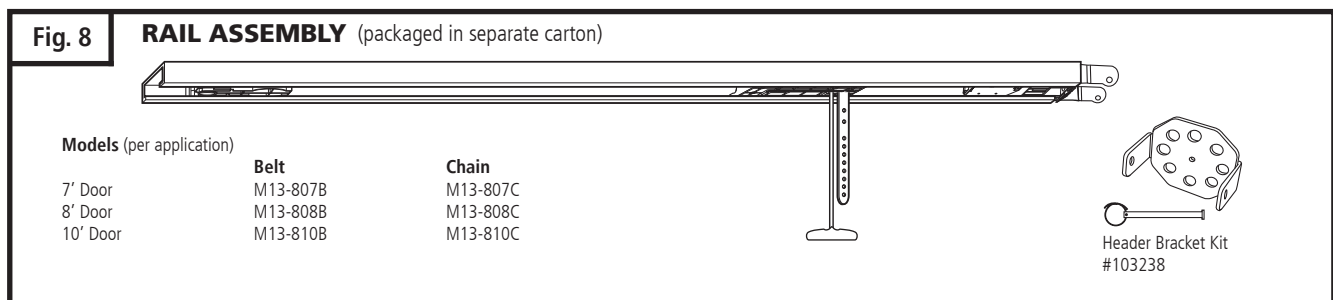
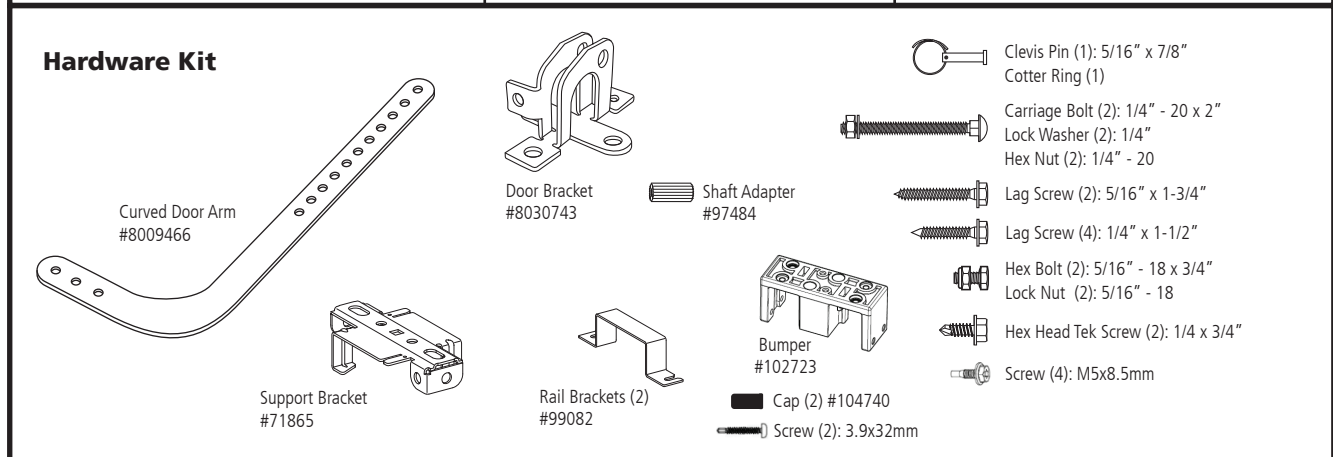
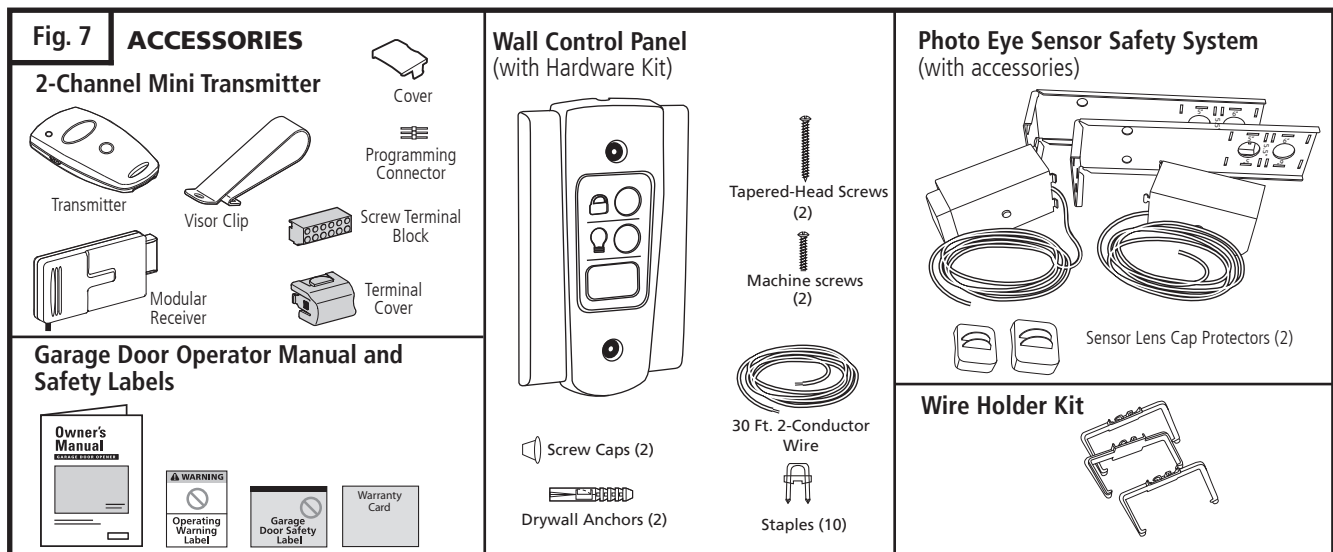
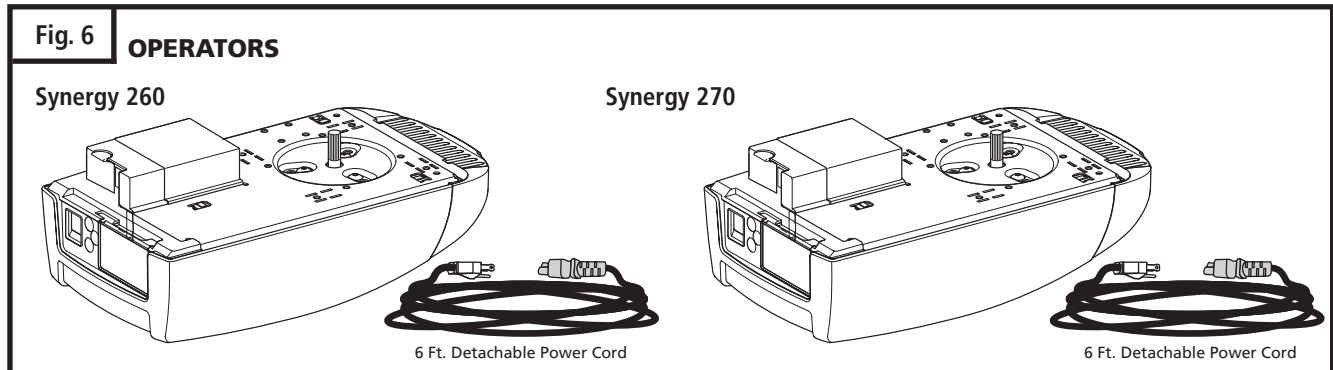

## 7. IMPORTANT INSTALLATION INSTRUCTIONS

### IMPORTANT INSTALLATION INSTRUCTIONS

# ⚠ WARNING ⚠

## TO REDUCE THE RISK OF SEVERE INJURY OR DEATH:

1. READ AND FOLLOW ALL WARNINGS AND INSTALLATION INSTRUCTIONS.
2. Check with the door manufacturer to determine if additional reinforcement is required to support the door prior to installation of the door operator.
3. Install operator only on a properly balanced garage door. An improperly balanced door could cause serious injury. Have a qualified service person make repairs to garage door cables, spring assemblies, and other hardware before installing the operator.
4. Remove all ropes and disable all locks connected to the garage door before installing operator.
5. If possible, install the door operator 7 feet (2.1m) or more above the floor. For products having an emergency release, adjust the emergency release cord for the handle to be within reach, but at least 6 feet (1.8m) above the floor and avoiding contact with vehicles to avoid accidental release.
6. Do not connect the operator to source of power until this manual instructs you to do so.
7. Locate the wall control station: (a) within sight of door, (b) at a minimum height of 5 feet (1.5m) above the ground so small children cannot reach it, and (c) away from all moving parts of the door.
8. Place the Operating Warning Label next to the wall control panel in a prominent location. Affix Safety Label on inside of garage door. The Emergency Release markings molded on handle.
9. After installing the operator, test Safety Reversal System. Door **MUST** reverse when it contacts a 1-1/2 inch (40mm) high object (or a 2x4 laid flat) on the floor.
10. **SAVE THESE INSTRUCTIONS** for future safety, adjustment, and maintenance purposes.

*For Important Safety Instructions see page 26.*

Shown on the right is an overall view of a completed garage door operator system installed on a sectional door. The arrangement is similar for a one-piece door (except for differences described later in this manual).

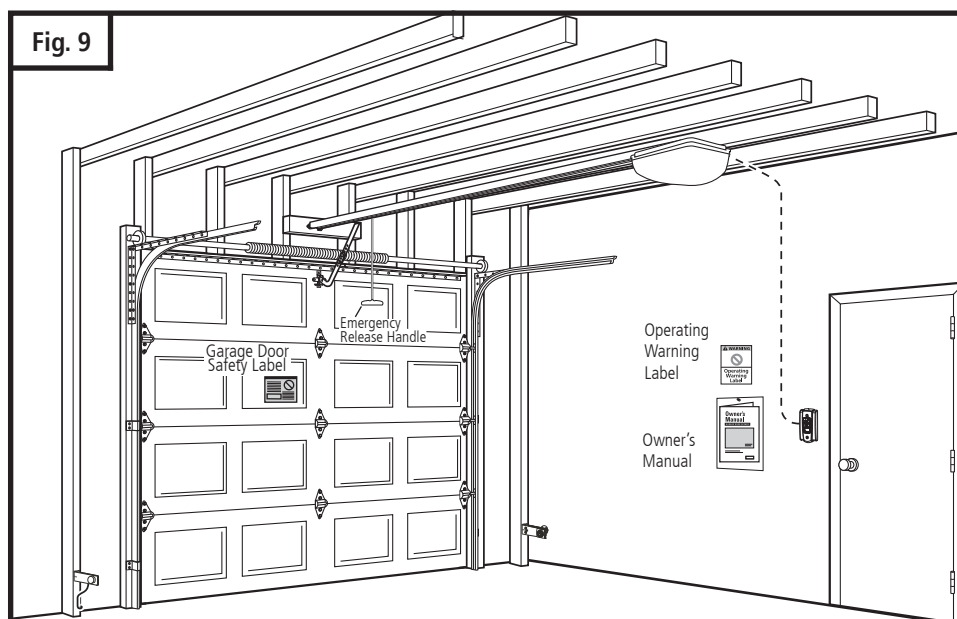

## 8. INSTALLATION STEPS

Identify a sound structural support on header wall above garage door for header bracket mounting. See Fig. 11. If appropriate header does not exist, replace or install a new support using a 2x4 or 2x6 board. Fasten it securely using lag screws (not provided) to structural supports of garage.

### 8-1. MEASURE AND MARK DOOR AREA

Before starting your installation, the door and the header above the door must be measured and marked. This way, the appropriate brackets can be mounted at the correct locations avoiding installation and operating difficulties later.

#### MARK VERTICAL CENTER LINE:

- Measure door width, then locate the center point (Fig. 10).
- Mark a vertical line on the upper half of your door, on the top edge of your door, and on the header, through the center point.

#### MEASURE DOOR'S HIGHEST TRAVEL POINT:

(Review Figs. on p. 5 for details)

- Open door to its highest travel point and measure from the garage floor to the top of door.
- Write down this distance.

#### FOR SECTIONAL DOORS AND ONE-PIECE DOORS WITH HORIZONTAL TRACK:

Add 1-1/4" to the door travel height (measured above).

#### FOR ONE-PIECE DOORS WITHOUT TRACK:

Add 3-3/4" to the door travel height (measured above).

#### MARK HORIZONTAL LINE FOR HEADER BRACKET LOCATION:

- Close door and measure the required distance (determined above) from the garage floor to the header.
- Mark a horizontal line, intersecting the vertical center line, on header. This is the position at which the bottom of the header bracket should be installed.
- In case of minimal clearance above the door, the header bracket may be mounted to the ceiling. In this case, extend the vertical center line onto the ceiling, and mark a horizontal line on the ceiling no further than 4" from the header wall. The header bracket should be mounted no farther than this distance from the header wall.

### 8-2. INSTALL HEADER BRACKET

#### ⚠ WARNING ⚠

*If the header bracket is not rigidly fastened to a sound structural support on the header wall or ceiling, the safety reverse system may not work and could cause serious injury or death. DO NOT move or adjust springs or garage door hardware, as these parts are under extreme tension and could cause injury or death.*

Fig. 10

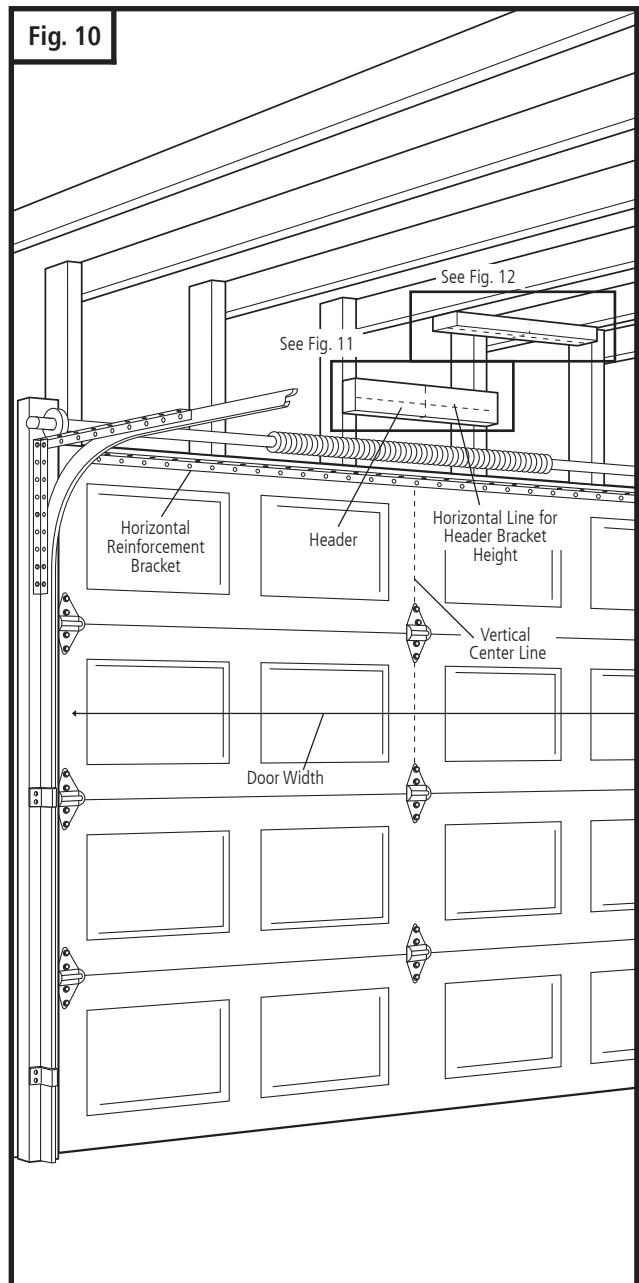
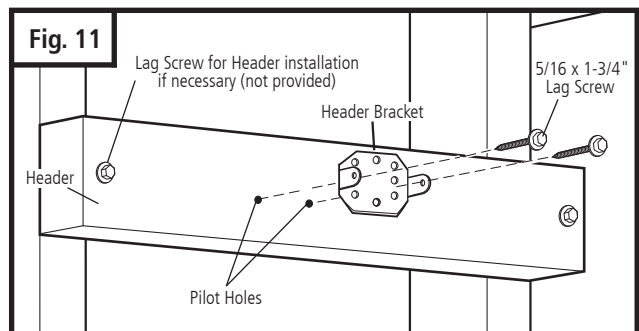

Fig. 11





## 8-2. INSTALL HEADER BRACKET (cont'd)

- Mark pilot holes location on header through header bracket holes where lag screws will be inserted.
- **IMPORTANT:** See Fig. 11 for which header bracket holes to use.
- Drill 3/16" pilot holes into header, and install bracket with lag screws (5/16 x 1-3/4") provided.
- Tighten lag screws firmly.

**NOTE:** Follow the same procedure if header (shown in Fig. 11) runs vertically instead of horizontally and is the only option for mounting header bracket to header wall. In case of minimal clearance above the garage door, the header bracket may be mounted to the ceiling. Follow the same steps above to ensure a sound surface for mounting.

## 8-3. INSTALL DOOR BRACKET TO DOOR

### A. FOR SECTIONAL DOORS:

#### Wood Sectional Doors (Fig. 14)

- Position door bracket (Fig. 13) along vertical center line of door with pin hole facing top of the door and top edge of the bracket 4" to 5" below top edge of the door, or roughly at the same height as top rollers on the door.
- Mark locations of securement holes through door bracket.
- Drill two 1/4" holes through door for securement of door bracket.
- Insert carriage bolts (1/4" x 2") from the outside through door and bracket, then secure with lock washers and nuts from the inside.
- Tighten nuts firmly.

#### Metal Sectional Doors

- Attach door bracket with two teck screws (provided) per Door manufacturer recommendations.

### B. FOR ONE-PIECE DOORS:

Before starting the installation of the door bracket, cut off mounting leg from opposite side of pin hole.

#### One-Piece Doors with Exposed Frames (Fig. 15)

- Position center of door bracket on the center line on the top edge of door.
- Mark the position where carriage bolts will go through bracket, and drill two 1/4" holes through top frame of door.
- Install carriage bolts from the bottom, through door frame and bracket, and secure with lock washer and nut from top.
- Tighten nuts firmly.

#### One-Piece Doors without Exposed Frames (Fig. 16)

- For doors without exposed frames, use alternate method of mounting door bracket.
- Mark and drill two 3/16" pilot holes into top of frame, then secure bracket with 5/16" x 1-5/8" lag screws (not provided).

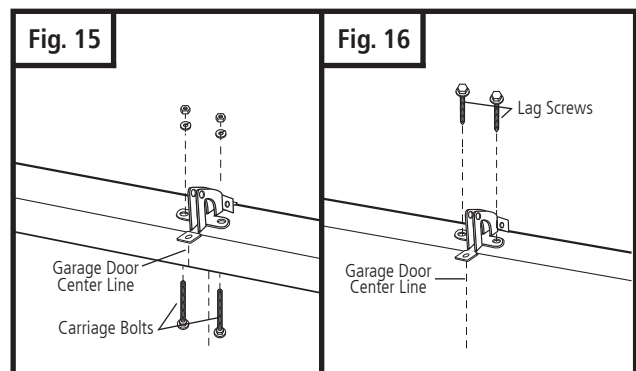
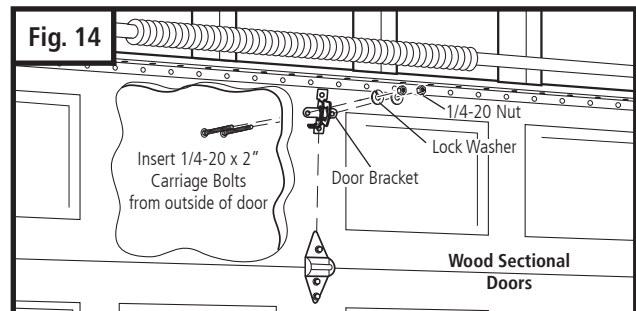
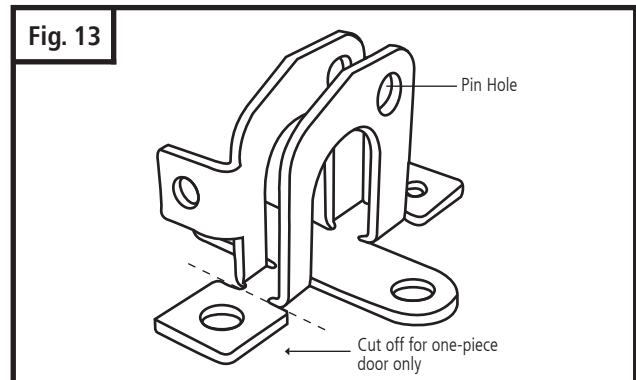
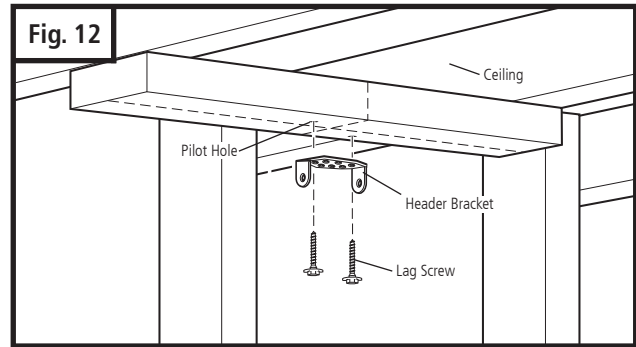

One-Piece Door  
with Exposed Frame:  
Install with Carriage Bolts

One-Piece Door  
without Exposed Frame:  
Install with Lag Screws(not provided)

## 8-4. ATTACH RAIL TO OPERATOR HEAD

### ⚠ WARNING ⚠

*When fastening the rail to the operator, use only the screws provided. Use of any other screws may result in operator falling from ceiling and causing damage to persons or property in the garage.*

**NOTE:** Rail comes fully preassembled with straight door arm already attached.

- Unpack one-piece preassembled rail.
- Leave straight door arm taped inside rail for safe and convenient installation—it will be untaped and used later.
- Position operator with control panel facing back of garage. Rest operator head on cardboard or protective surface on floor so opener does not get scratched.
- Position rail onto operator chassis by lining up rail sprocket opening with motor head shaft (Fig. 17). Make sure shaft engages teeth inside rail sprocket. Press rail down firmly onto shaft and opener chassis. **DO NOT HAMMER.**
- Position the two rail brackets over rail as shown in Fig. 17.
- Insert screws (M5 x 8.5) through bracket holes and into chassis holes, and tighten screws firmly to hold rail to head.
- For sectional doors, proceed to step 8-5.

### ADDITIONAL STEP FOR ONE-PIECE DOORS ONLY:

**IMPORTANT NOTE:** For installation on One-Piece Doors only, the straight door arm that is factory installed onto the rail must be replaced by the curved door arm supplied as part of hardware in powerhead box. This must be done after attaching rail to powerhead, before moving to step 8-5.

- Turn rail and operator over so that open channel in rail faces up.
- Untape straight door arm that is secured inside rail.
- Remove and save the two phillips head screws that are securing the door arm pin and straight door arm (Fig. 18).
- Lift arm and pin straight out of slot in trolley, and remove pin from straight door arm.
- Insert pin into short side of curved door arm as shown.
- Orient arm so that long side extends away from trolley.
- Carefully insert pin and door arm into slot in trolley. Push pin into slot with door arm so pin is fully seated into trolley slot. **IMPORTANT:** Pin must be straight and seated properly into recessed area in trolley. See Figs. 18A and 18B.
- Secure pin and curved arm with the two phillips screws which were removed from trolley—**DO NOT** use any other screws. Tighten screws firmly.
- Turn rail and powerhead over so that open channel in rail faces down. Now proceed to Step 8-5.

Fig. 17 Standard Application

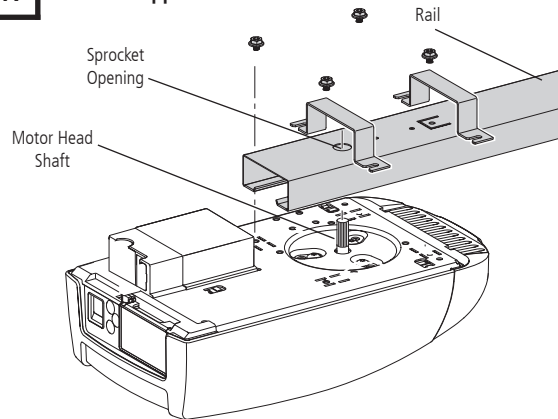

Alternate Rail Installation (Space Saver Applications)

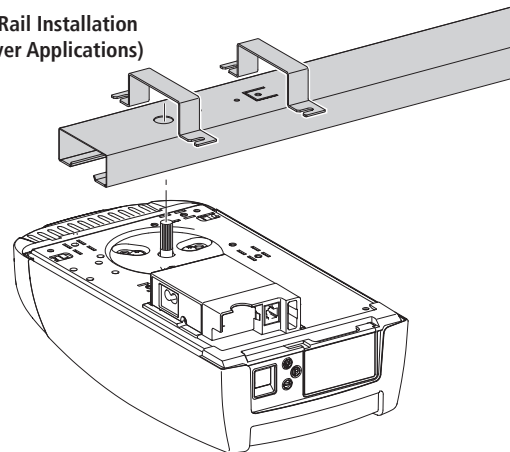

Fig. 18

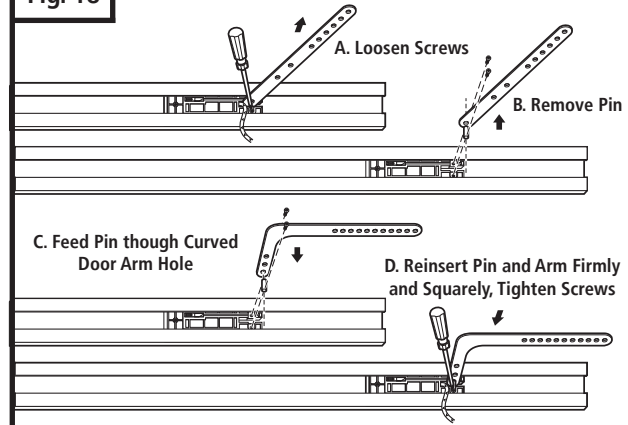
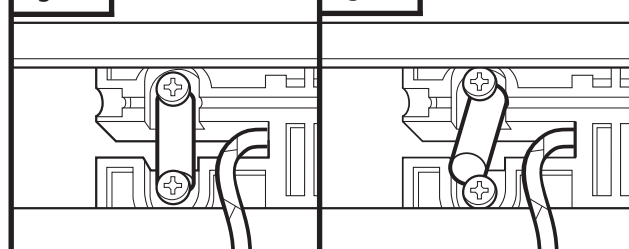

Fig. 18A

Correctly seated pin.

Fig. 18B

Incorrectly seated pin.



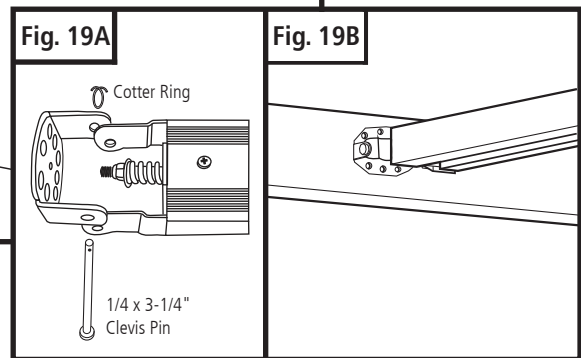
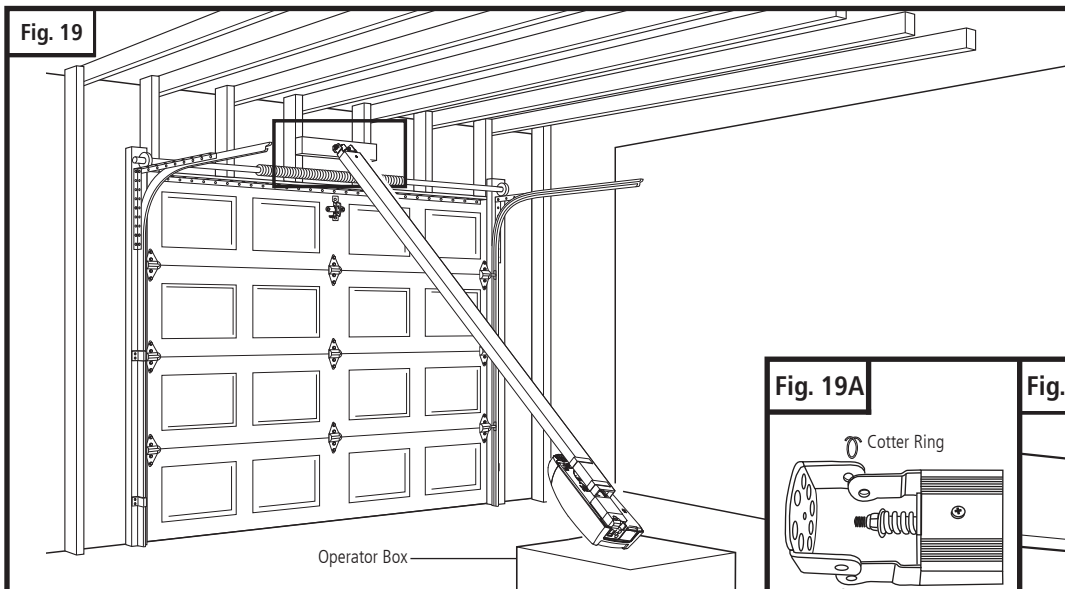

### 8-5. ATTACH RAIL TO HEADER BRACKET

- Support operator head slightly off the floor.
- Lift the opposite end of the rail up to the header bracket.
- Position rail end-stop within the openings in the header bracket. Insert header clevis pin ( 1/4" dia.) through header bracket and rail end, then attach cotter ring to end of pin. (See Fig. 19A)

### 8-6. POSITION OPERATOR FOR MOUNTING

Once rail is attached to header bracket, support operator on ladder, or use the assistance of another person to support operator high enough so door can open without hitting the rail.

#### A. SECTIONAL DOORS AND ONE-PIECE DOORS WITH TRACK:

- Open garage door to fully opened position, and place a 2x4 laid flat between the door and the rail. See Fig. 20. This provides an easy method of ensuring the correct mounting height of the opener.

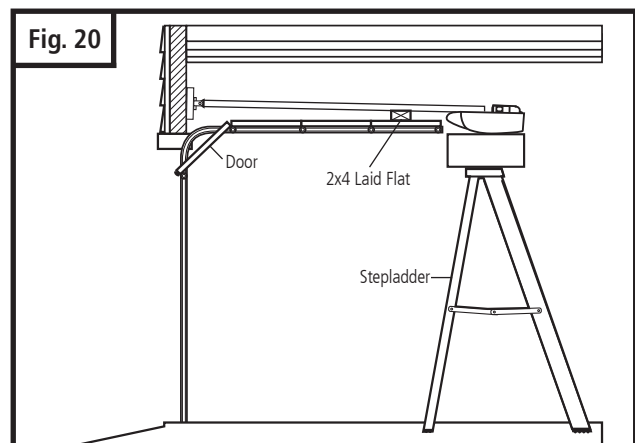

#### B. ONE-PIECE DOORS WITHOUT TRACK:

- Disconnect trolley by pulling down on emergency release knob. Move trolley toward opener head.
- Open door all the way so that it is parallel to the floor, or slightly tilted toward the front of the garage. DOOR SHOULD NOT BE TILTED TOWARD THE BACK OF GARAGE.
- Position operator so that top of operator head is level with top of opened door.
- To check for correct mounting height, temporarily position curved door arm as if connecting to door bracket. See Fig. 21. The long side of the arm should be parallel to the floor when door is fully opened. Raise or lower powerhead so that arm will be parallel to floor.
- Temporarily support head at this height, and prepare to mount the operator to ceiling.

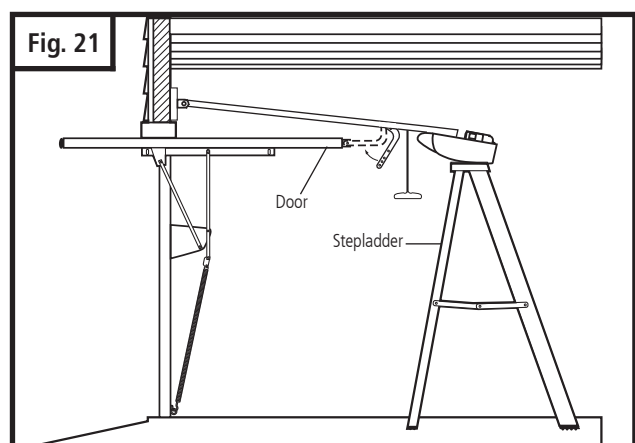

## 8-7. MOUNT OPERATOR TO CEILING

### ⚠ WARNING ⚠

*If not properly secured, the operator could fall and injure someone. Secure opener to structural supports or framing. Do not mount to drywall, plaster, or other such material.*

- Place mounting bracket over rail (close side) on a diagonal. Make sure support securement clamps clear rail sides.
- Twist mounting bracket and secure onto rail 12" from sprcket end side of rail as shown in Fig. 22.
- Attach mounting strap or perforated angels (not provided) to mounting bracket and secure by fastening it to the ceiling.

**NOTE: 10' doors require two brackets installation as shown in Fig. 23.**

- Measure the rail's overall span. Locate support bracket  $\frac{1}{3}$ " of full span from the rail end side as shown in Fig. 23.

## 8-8. CONNECT ARM TO DOOR AND TROLLEY

- Make sure door is fully closed.
- Remove tape from rail holding straight door arm (sectional door only) and allow door arm to hang freely.
- Pull the manual release cord on the trolley to disconnect trolley from chain or belt connector. Slide trolley to position it approximately 6-8" away from the door.

### A. SECTIONAL DOORS:

- Position curved door arm into door bracket channel so that short end of arm will be attached to door bracket. See Fig. 25. Curved door arm should be attached roughly at the same height as the top rollers of the door.
- Align curved door arm and bracket holes, then insert clevis pin through holes. Attach cotter ring to hold pin in place.
- Position straight arm and curved arm to form an angle with the door (Fig. 24) and at least two sets of holes line up. Select two overlapping holes as far apart as possible and secure arms together with hex bolts (5/16-18) and lock nuts.

### B. ALL ONE-PIECE DOORS:

- Curved door arm should already be attached to trolley in place of straight door arm. See Fig. 18, p. 10.
- Position free end of curved arm into door bracket slot. Align curved door arm and bracket holes, then insert clevis pin (5/16" dia.) through holes. Attach cotter ring to pin to hold in place. See Fig. 25A.

### C. SECTIONAL AND ONE-PIECE DOORS:

- After connecting appropriate door arm, ensure trolley is disengaged. Check for proper door operation by manually lifting then lowering to fully opened and closed positions.
- Readjust door arm if needed.

Fig. 22

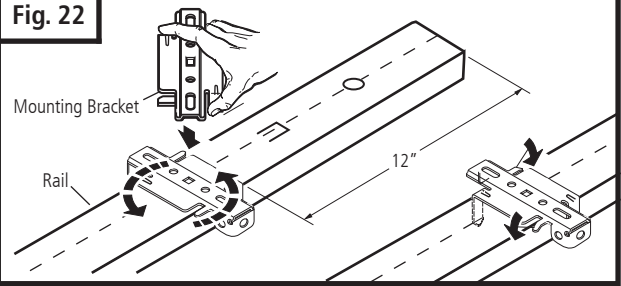

Fig. 23

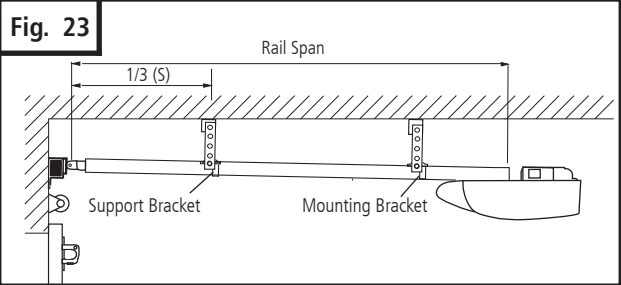

Fig. 24

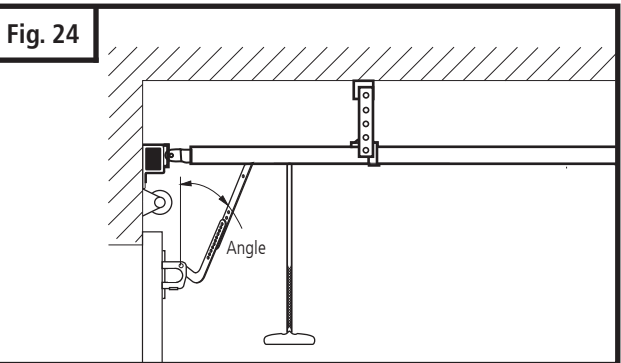

Fig. 25

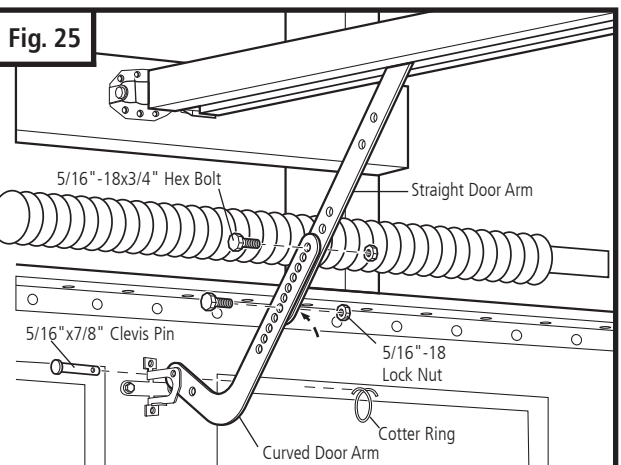
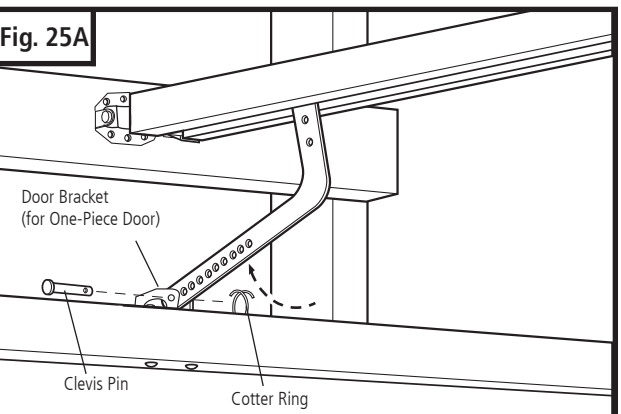

Fig. 25A



## 8-9. RAIL BUMPER INSTALLATION

- With the trolley in the unlock position, move door up to the location desired. See Fig. 26.
- Snap rail bumper as shown in Fig. 26A.
- Hold door and measure approximately 1/2" from trolley end as shown in Fig. 26B. This is the installation location for the rail bumper.
- Secure bumper with screws and cover screws with plastic caps (provided) as shown on Fig. 26B.

### IMPORTANT NOTE

**PULL DOWN ON RELEASE HANDLE TO LOCK TROLLEY, THEN MOVE DOOR MANUALLY UNTIL TROLLEY LOCKS WITH CHAIN OR BELT CONNECTOR.**

## 8-10. CHECK EMERGENCY RELEASE

### WARNING

To prevent possible **SERIOUS INJURY** or **DEATH** from a falling garage door:

- If possible, use emergency release handle to disengage trolley **ONLY** when garage door is **CLOSED**. Weak or broken springs or unbalanced door could result in an open door falling rapidly and/or unexpectedly.
- **NEVER** use emergency release handle unless garage doorway is clear of persons and obstructions.
- **NEVER** use handle to pull door open or closed.

Fig. 27

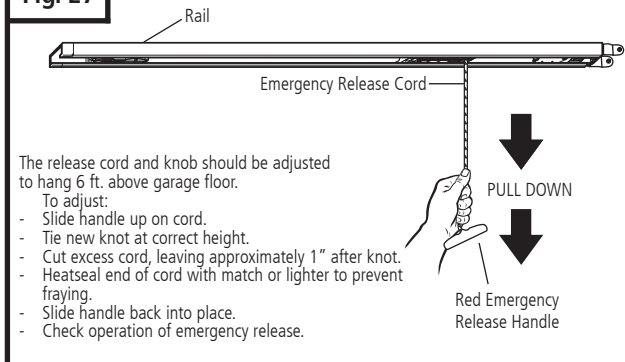

The emergency release cord with red handle which is already attached to the trolley, are extremely important parts of the operator system Fig. 27. Pulling the release cord disengages the door from the opener. This allows the door to be moved manually up and down independent of the opener motor.

**If the door is in the open position, use extreme care when using the release.**

Use emergency release to disconnect the door if the power is out. It should also be used if for some unforeseen reason the door strikes a person or object during its travel and does not automatically reverse off the obstruction.

**To release door - pull firmly down on red handle. (Fig. 27)**

Prior to re-engaging door, ensure that all obstructions are removed and door is operating properly manually. Before re-engaging trolley with a chain or belt connector, pull down handle again, then release. The red catch will stop in the "lock" position and will open indicator window (see Fig. 27A). Now the door can be reconnected by moving it manually and bringing it into position when the connector is inside of the trolley.

Fig. 26

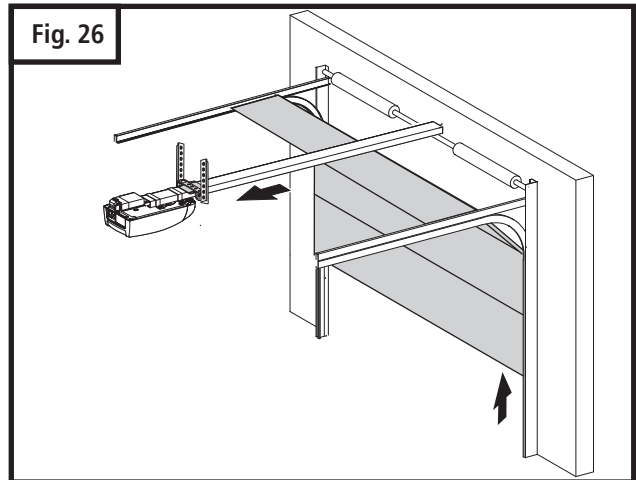

Fig. 26A

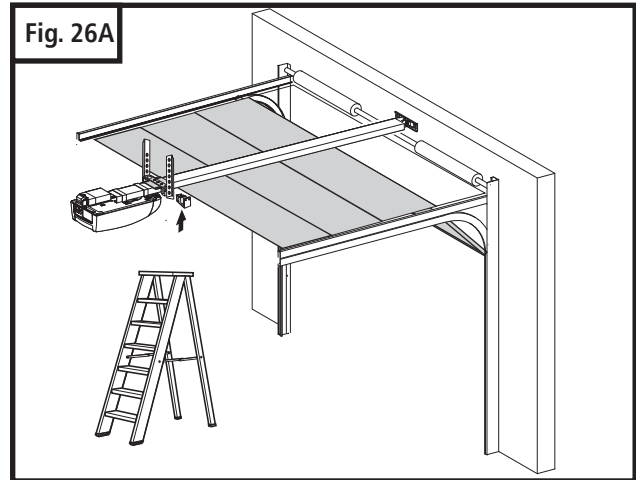

Fig. 26B

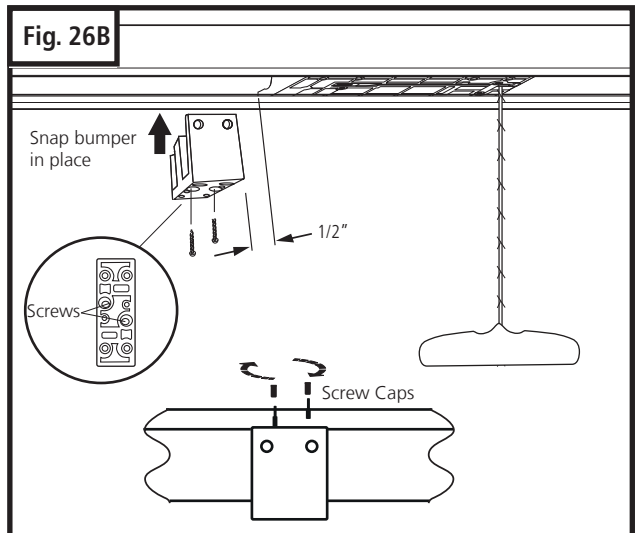
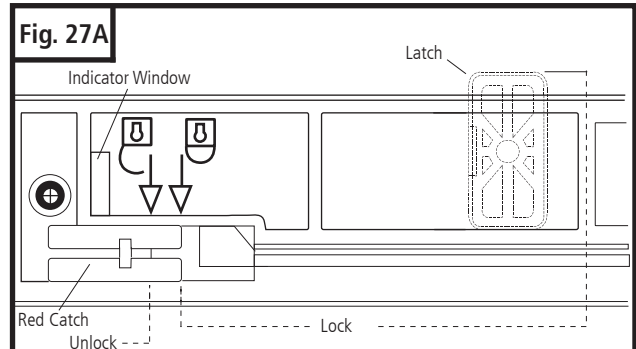

Fig. 27A



## 8-11. INSTALL PHOTO EYE SAFETY SYSTEM

### CAUTION

To provide the maximum amount of protection, the photo eye sensors must be mounted between 3.5" and 5" above the floor. See Fig. 28.

#### MOUNTING THE PHOTO EYE SENSOR BRACKETS TO WALL:

- Locate the mounting position for brackets (bracket can be mounted in any position as long as photo eye beam will have a clear path from one side of door to other side after mounting).
- Use the bracket mounting holes as a template to locate an drill (2) 3/16" diameter pilot holes on both sides of the garage door as shown in Fig. 28.
- Secure the bracket with 1/4" x 1-1/2" lag screws provided as shown in Fig. 28.

#### MOUNTING THE PHOTO EYE SENSORS TO MOUNTING BRACKET. Fig. 29

- Install the sensors to the mounting bracket by inserting bend clips of sensor bracket through the vertical slot on mounting bracket.
- Insert straight clips through other set of vertical slot on the mounting bracket.
- Twist one of the straight clips slightly to lock the sensor in place once inserted through vertical slot on the mounting bracket.
- Repeat the above procedure for the other sensor.

#### SENSOR PROTECTION Fig. 30

- Before performing maintenance work in garage, such as, power washing, painting, and other tasks; protect sensors with provided sensor caps.

#### DUAL DOOR INSTALLATION Fig. 31

- In dual door installations, the transmitter (TX) and the receiver (RX) photo eye sensors (as marked on each of the photo eye components) should be mounted as indicate in Fig. 31. TX and RX marks located on the back side of the transmitter and receiver.

## 8-12. INSTALL WALL CONTROL PANEL

The control panel must be mounted inside the garage within sight of the garage door, clear of all moving garage door parts or any associated parts - and at least 5 feet above the floor to prevent the use of these controls by children. The device should only be used when the door is in clear sight of the user and the door area is free of people or any obstructions.

- Attach 2-conductor wire to the screw terminal on back of control panel. See Fig. 32 (Back). White wire attaches to terminal #3 screw, white wire with color stripes attaches to terminal #4 screw.
- Position wall control panel onto wall in desired location.
- Mark hole location on wall.
- Drill 1/16" pilot holes into wall.
- Insert and tighten screws to secure control panel to wall.
- Make sure wiring is routed out from behind control through one of the cutouts to avoid pinching the wires.

If mounting to drywall instead of wood, drill 3/16" pilot holes and use anchors provided. If mounting to electrical box that is prewired for this purpose, mount directly to box with proper screws provided. See Fig. 32A.

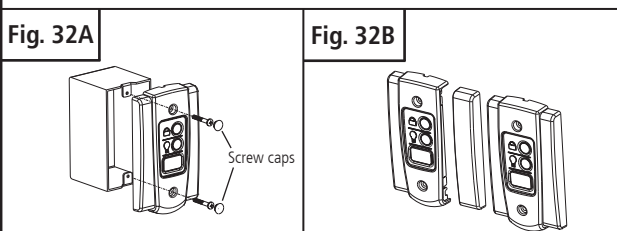
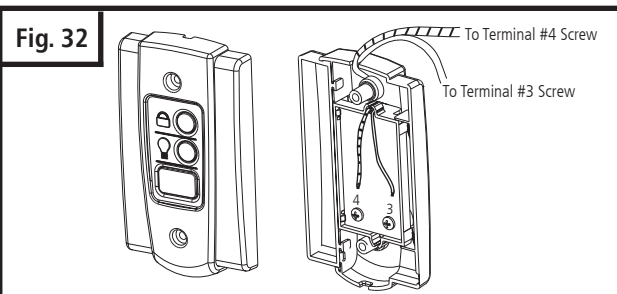
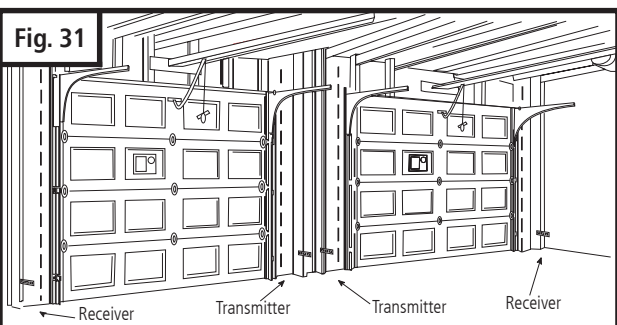
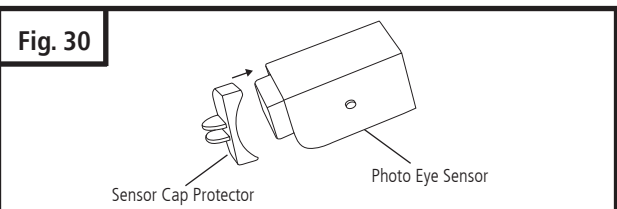
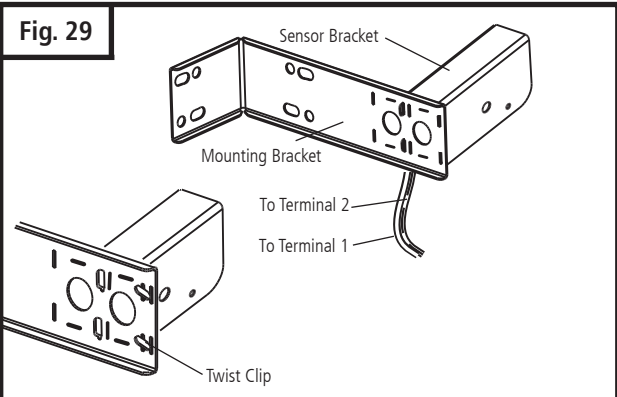
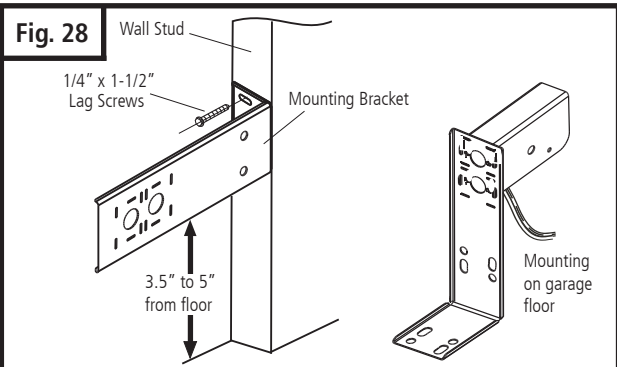

## 9. CONTROL UNIT CONNECTIONS



### WARNING

**Danger of electric shock:**  
Before any wiring works being, make sure that all wiring is disconnected from the power supply. During wiring make sure all wires remain disconnected from the power supply at all times.

XB03	Connection for - Wall Control - Photo eyes
XB72	Connection for modular antenna
XW40	Connection for MS bus expansion module Not available
XW81	Connection for expansion inputs / outputs

Fig. 33

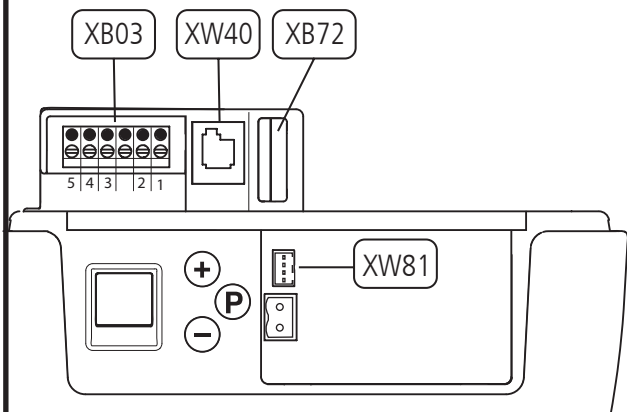

Fig. 34 Modular Antenna Installation or Replacement

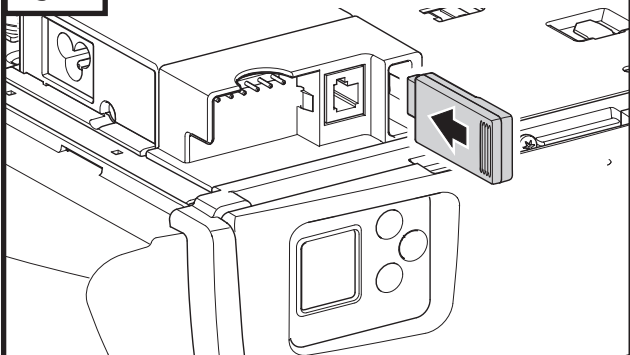

Fig. 35 Terminal block XB03

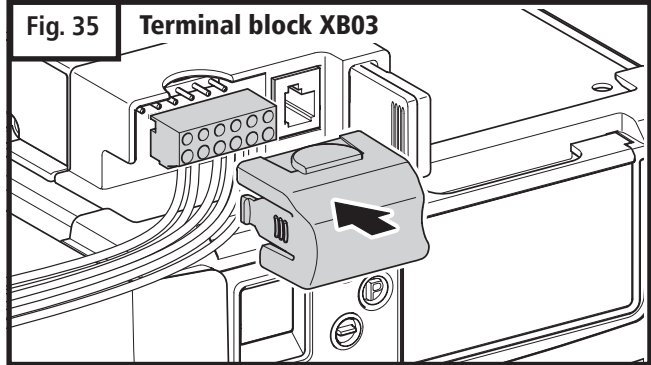
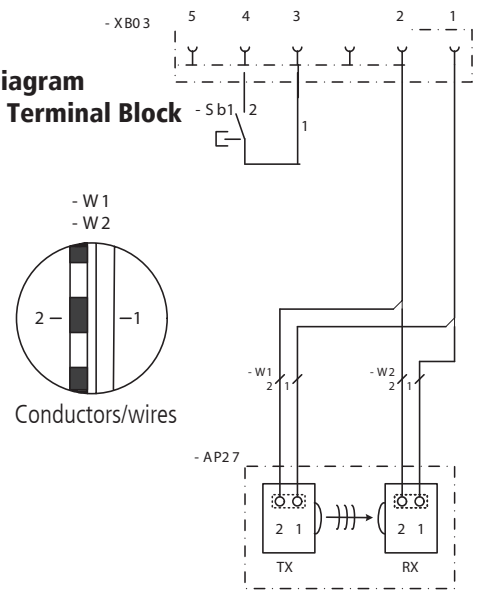

Fig. 36

Wiring Diagram for XB03 Terminal Block



AP27	Photo eye safety system
RX	Photo eye receiver
TX	Photo eye transmitter
1	Photo eye - Conductor 1
2	Photo eye - Conductor 2
Sb1	Impulse button - Wall Control
3	Wall control - Impulse - Conductor 1
4	Wall control - GROUND - Conductor 2
5	24 V DC

## 10. CONNECT TO POWER

To reduce the risk of electric shock, your opener is provided with an insulated power cord with a 3-prong grounding plug. The cord must be connected to a standard grounding outlet. If there is no outlet available at the location, you must have a qualified electrician install an approved grounded outlet in this area.

### **⚡ WARNING ⚡**

*To prevent electrocution or fire, installation and wiring must be done in accordance with local electrical and building codes. DO NOT use an extension cord. DO NOT use a 3 to 2 plug adapter. DO NOT modify or cut off the grounding pin on the plug.*

- Plug the operator into a properly grounded outlet (Fig. 37).
- The display will illuminate the word "On" and  will be displayed. This indicates that the operator is ready for set up. See fig. 38A for additional display icons.
- DO NOT operate or run the opener at this time.

### **IMPORTANT:**

#### **Contact Marantec America for Replacement Power Cord**

Part #102807  
Model: YP-12/YC-12  
Overall length 6ft.  
UL/CSA Recognized  
UL Type: E241374: SJT 3/C 18AWG 105°C 300V VW-1  
CSA 177323: SJT 3/C 18AWG 105°C 300V FT2

Fig. 37

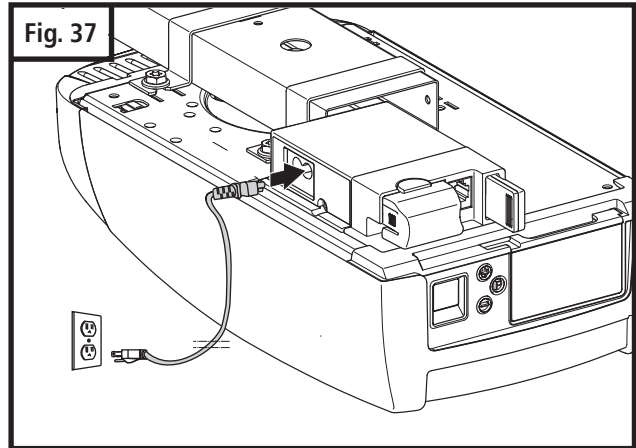



## 11. INITIAL SYSTEM SET UP

### ⚠ WARNING ⚠

In order to guarantee a trouble-free programming:

- The door must be in the "CLOSED" position and engaged to the drive system (rail) before programming the operator or a system reset is performed.

For proper initial operation of the operator, two basic functions must be set using the initial system programming:

- Open Door Position
- Close Door Position

Press and hold the "P" button for approximately 3 seconds. When  illuminates, release the button. You are now ready to set or change the desired adjustment. If no buttons are pressed within 120 seconds while in programming mode, the control unit reverts back to operating mode.

### TO MAKE OR CHANGE ANY ADJUSTMENT:







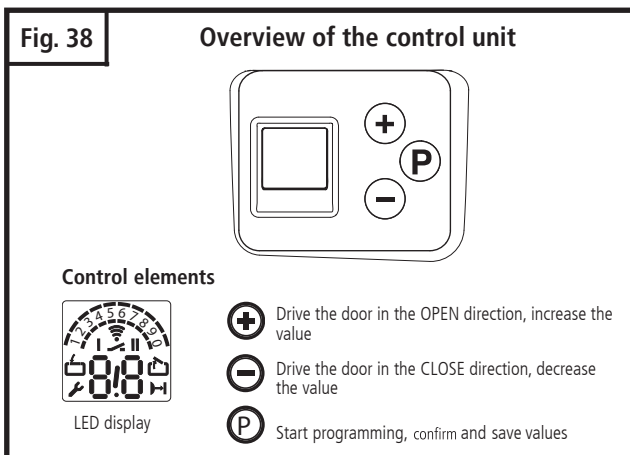



**NOTE:** If no changes are needed at any particular stage, you can keep the current information and "skip" over a specific adjustment by pressing the "P" button once. This is useful to know if you want to change only one setting, without changing any of the other adjustments. Simply enter the adjustment mode by pressing and holding the "P" button for approximately 2 seconds, then press and release "P" repeatedly until your particular adjustment is reached. This bypasses the unneeded adjustments, and takes you right to the adjustment you want. When your adjustment or setting is complete, simply press "P" as many times as needed to bypass the remaining steps and exit out of the program, returning the operator to normal mode.

Your new operator has automatic force learning and maximum force setting. It may be required to change force settings. If the force needs to be increased or decreased, it should be changed by one (1) increment at a time. The force should be set as low as possible, just enough to allow your unobstructed door to travel freely without reversing or stopping.





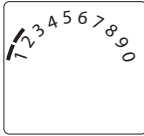
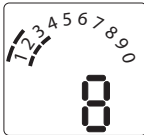

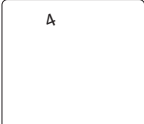











**NOTE:** You may exit the System Set Up at any time by pressing the button "P" for more than 5 sec. The set up programming can be terminated at any time and from any stage. To do so, press the "P" button for longer than 5 seconds.



**Fig. 38A**

Display	Description
	Ready for operation
	Door position: CLOSED
	Door position: OPEN
	Fault message / Maintenance indicator in CLOSED door position
	Photocell safety device
	Remote control
	External button
	Status display Battery backup system connected
	Level indicator (Example: Level 2) Display shows Level 2
	Menu and parameter indicator (Displayed Menu 3, Parameter Setting 8)
Minute indicator	
	Times exceeding one minute are shown in minutes and seconds. Example: 1.2 = 1 minute + 20 seconds = 80 seconds
Status display	
Display	Function / Element
	Warning time indicator (only for programmed automatic closing)

## 11. INITIAL SYSTEM SET UP (cont'd)

 Power on	<b>1 Programming the "OPEN" door position</b>		
		The control system is in operating mode.	
		P > 3 sec. < 10 sec.: Start express programming.	
		Drive the door to the OPEN position.	
		Save the OPEN position.	
	<b>2 Programming the "CLOSED" door position</b>		
		Drive the door to the CLOSED position.	
		Save the CLOSED position.	
	<b>3 Programming the remote control</b>		
		Press the hand transmitter button.	
		Release the hand transmitter button.	
		Save the remote control setting. End express programming.	
	The control system is in operating mode.		
		 Operating mode	













### **NORMAL OPERATION** **IMPORTANT:**

*On the first open travel activation the trolley will make contact and will rest against the rail bumper. This will appear as if the system (door) went pass the set open travel limit. However this is not the case, on the next open travel cycle the system will recognize the set open travel limit thereafter activation of the system. Every 20 cycles the operator will performed a travel limit check and it will function as described on "Normal Operation" note.*

### **IMPORTANT:**

*Upon completion of the initial set up, the operator must be cycled for two complete cycles (complete cycle comprises of one uninterrupted up activation of the system and one uninterrupted down activation of the system).*











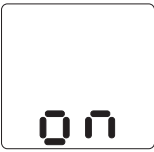

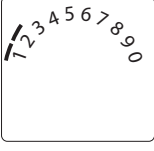

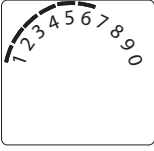

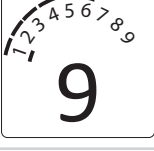

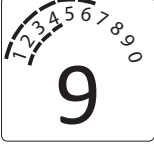
### **Legend:**

Drive the door in the OPEN direction, increase the value	
Drive the door in the CLOSE direction, decrease the value	
Start programming, confirm and save values	
The display flashes	
Display lights up	
Ready for operation	
Door position: CLOSED	
Door position: OPEN	
Fault message/Maintenance indicator in CLOSED door position	
Photocell or closing edge safety device	
Remote control	
External button	

## 12. ADVANCED SETTINGS

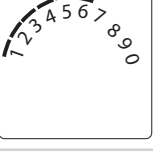
### CAUTION

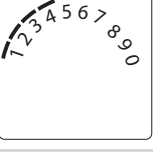
Additional operator functions can be set using the advanced operator functions. Parameters factory default settings can be restored. This programming may only be carried out by a professional installer.

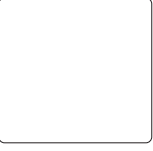
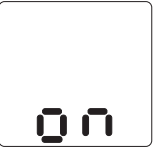
Advanced Settings Programming Procedure (Diagram Illustrates Setting of Level 6, Menu 4)			
1.	The control system in operating mode.		
2.	 P > 10 sec.: Start programming the advanced operator functions. Displayed starting level.		
3.	  Select the level required (Example: Level 6).		
4.	 Confirm the level shows the first menu and the setting for level parameter.		
5.	  Select menu that needs adjustment (Example: Menu 4)		
6.	 Confirms menu. Parameter setting blinks.		
7.	  Change parameter setting.		
8.	 Saves parameter setting and to display levels.		
9.	  Select a new level to continue, repeat steps - step 8 to make other adjustments.		
	<b>or</b>		
	 P > 5 sec.: All changed parameter settings are saved.		
	The control system switches to operating mode.		

**Note: Level 3 is disable**

## 12. ADVANCED SETTINGS (cont'd)

### CAUTION

After a system reset, all parameters are restored to the factory settings.

- All the required function in the initial set up and advanced settings must be re-programmed if it is required.
- The operator must be activated for two (2) complete uninterrupted cycles in order for all restored or operating parameters settings to be learned by the operator again.

#### General overview of the programmable functions

Level	Menu	Factory default setting (  )
Level 1 – Basic function	Menu 3: Intermediate “OPEN Position”	
	Menu 8: RESET	
Level 2 – Operator settings	Menu 1: “OPEN” position – operator (system) force	Setting 8
	Menu 2: “CLOSE” position – operator (system) force	Setting 8
	Menu 3: “OPEN” position – operator sensitivity	Setting 15
	Menu 4: “CLOSE” position – operator sensitivity	Setting 15
Level 4 – Transmitter Additional Functions	Menu 2: “Intermediate “OPEN Position”	
Level 5	Menu 4: Light timer	Setting 16
Level 6 – Variable speed	Menu 1: OPEN speed	Setting 16
	Menu 2: Soft run OPEN speed	Setting 7
	Menu 3: Soft run OPEN position	
	Menu 4: CLOSE speed	Setting 16
	Menu 6: Soft run CLOSE speed	Setting 7
	Menu 8: Soft run CLOSE position	
Level 7 – Maintenance and servicing	Menu 1: Door cycle counter	
	Menu 2: Servicing counter	
	Menu 3: Servicing interval	
	Menu 8: Reset maintenance and servicing	
	Menu 9: Fault indicator	
Level 8	Menu 7: Force relief CLOSED door position	Setting 1 - Not Active

#### Level 1: Basic Functions

##### Menu 3: Intermediate OPEN Position





Set using the (+ / OPEN) and (- / CLOSE) buttons  
The closing function with automatic closing is possible. Only the intermediate position that was programmed last can be used.

##### Menu 8: System RESET

1	 No reset
2	Reset system settings

## 12. ADVANCED SETTINGS (cont'd)

### Level 2: Operator settings

<b>Menu 1: "OPEN" position operator (system) operating force</b> ← Lower Force Higher Force →																
 8	1	2	3	4	5	6	7	8	9	10	11	12	13	14	15	16
<b>Menu 2: "CLOSE" position operator (system) operating force</b> ← Lower Force Higher Force →																
 8	1	2	3	4	5	6	7	8	9	10	11	12	13	14	15	16
<b>Menu 3: "OPEN" position operator sensitivity</b>   ← More Sensitive Less sensitive →																
 10	OFF	2	3	4	5	6	7	8	9	10	11	12	13	14	15	16
<b>Menu 4: "CLOSE" position operator sensitivity</b> ← More Sensitive Less sensitive →																
 10	OFF	2	3	4	5	6	7	8	9	10	11	12	13	14	15	16





### Level 4: Transmitter Additional Functions

<b>Menu 2: Intermediate OPEN Position</b>															
Set using the (+ / OPEN) and (- / CLOSE) buttons The closing function with automatic closing is possible. Only the intermediate position that was programmed last can be used.															

### Level 5: Functions overview

<b>Menu 4: Operator Light "ON" Timer (in seconds)</b>															
 2	5	10	15	20	25	30	35	40	50	80	100	120	150	180	255

### Level 6: Variable Speed

<b>Menu 1: OPEN speed</b> ← Slower Faster →																
 16	-	-	-	-	5	6	7	8	9	10	11	12	13	14	15	16
<b>Menu 2: Soft run OPEN speed</b> ← Slower Faster →																
 7	1	2	3	4	5	6	7	-	-	-	-	-	-	-	-	-
<b>Menu 3: Soft run OPEN position</b>																
Set using the (+ / OPEN) and (- / CLOSE) buttons																
<b>Menu 4: CLOSE speed</b> ← Slower Faster →																
 16	-	-	-	-	5	6	7	8	9	10	11	12	13	14	15	16
<b>Menu 6: Soft run CLOSE speed</b> ← Slower Faster →																
 7	1	2	3	4	5	6	7	-	-	-	-	-	-	-	-	-
<b>Menu 8: Soft run CLOSE position</b>																
Set using the (+ / OPEN) and (- / CLOSE) buttons																

## 12. ADVANCED SETTINGS (cont'd)

### Level 7 – Maintenance and servicing

<b>Menu 1: Door cycle counter</b>
Six-figure indicator showing the number of complete cycles, up to 999999. Once the counter setting is reached, it restarts count again.
<b>Menu 2: Servicing counter</b>
Five-figure indicator showing the number of complete cycles left up to maintenance indication. Figures shown one after the other up to the indicator point, then repeated.

### Menu 3: Service/Maintenance Counter Setting

Adjustment of the number of door operations to be completed before a servicing reminder is displayed.

 1	OFF Default
2	100 door operations
3	500 door operations
4	1,000 door operations
5	4,000 door operations
6	5,000 door operations
7	6,000 door operations
8	7,000 door operations
9	8,000 door operations
10	9,000 door operations
11	10,000 door operations
12	15,000 door operations
13	20,000 door operations
14	30,000 door operations
15	40,000 door operations
16	50,000 door operations



### Menu 8: Reset maintenance and servicing

The fault log for maintenance, diagnostics and servicing work is reset here.

 1	No Reset - Default Setting
2	Reset the fault log

### Menu 9: Fault indicator

Shows the current fault message.  
(No more than 16 fault messages can be viewed).

	Display the previous fault / Navigate through the list of faults
	Navigate through the list of faults

### Level 8 - CLOSE Travel Position Pressure Sensitivity Adjustment (PSA™)

 1	Default not activated
2	Short
3	Medium
4	Long

## 13. TRANSMITTERS

### WARNING

**Danger of injury due to uncontrolled operation of the door!**

- Operate the controls or the hand transmitter only when there are no persons or objects in the path of the door.
- Ensure that the controls and the hand transmitter are never used by children or unauthorized persons.
- Ensure that the hand transmitter cannot be operated by accident (in a trouser pocket, for example).

### WARNING







**Danger of damage to property due to uncontrolled movement of the door!**

**When the door moves, the hand chain can get caught and this could result in damage (in case of ceiling-mounted supports for example)**

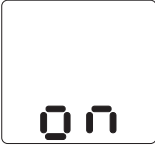

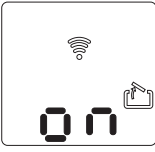

- Ensure that there are no obstacles blocking the path of the door or the hand chain.

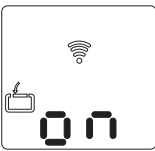
The operator works with the supplied hand transmitter on the basis of a pulse sequence control system.

#### Operating the door using the hand transmitter

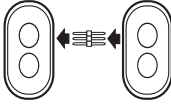
1.		The control system is in operating mode.	
2.		1. Impulse: The door opens and moves in the OPEN direction	
3.		2. Impulse. The operator system stops.	
4.		3. Impulse: The door moves in the opposite direction (CLOSE direction).	

#### Transmitting the code

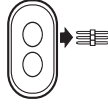
1.		Connect the hand transmitter to the programming connector
2.		Press the button on the master transmitter with active code. Keep the button pressed. The LED lights up.
3.		Press the button on the hand transmitter which is to be given a new code. The LED flashes.
4.		The LED lights up. The coding procedure is completed.
5.		Remove the programming connector.

**NOTE:** For multi-button transmitters, be sure to carry out this procedure for all the buttons you desire to use.

#### Changing the code

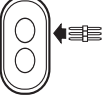
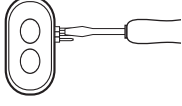
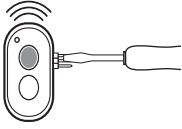
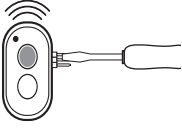
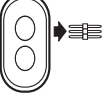
1.		Plug the programming connector into the hand transmitter.
2.		Short-circuit one of the two outer pins with the centre pin adjacent to it (e.g. using a screw driver).
3.		Press the desired button on the hand transmitter. The LED flashes.
4.		The LED lights up. The coding procedure is completed.
5.		Remove the transmission plug.
6.	Once the transmitter code is changed, the operator must be recoded with the new transmitter code as described on the initial system set up page 18.	

**NOTE:** For multi-button transmitters, be sure to carry out this procedure for all the buttons you desire to use.

## 13. TRANSMITTERS (cont'd)

### TRANSMITTERS (Fig. 39):

A family of state-of-the-art transmitters, each transmitter is custom encoded with installed battery. Offered in two styles to suit your personal preference.

- Mini (2-or 4-channel)
- Micro (3-channel) with keyring attachment.

### TRANSMITTER MOUNTING:

The transmitters can be conveniently mounted inside your car using the visor clip or on the wall using the mounting plate.

#### Visor Clip (Fig. 40)

- Snap visor clip into transmitter.
- Affix assembly to visor.

**NOTE:** If you do not need the visor clip, install the visor compartment cover.

#### Mounting Plate (Fig. 41) Optional Accessory

- Secure the mounting plate to area of preference using screw and anchor.
- Snap the visor compartment cover.
- Slide the transmitter into the mounting plate, which will hold it firmly in place.

### BATTERY REPLACEMENT (Fig. 42):

- Open the transmitter by using small coin.
- Insert a 3V battery (type CR2032) as shown.
- Close the transmitter.

**NOTE:** Replace batteries with same type only.

Fig. 39

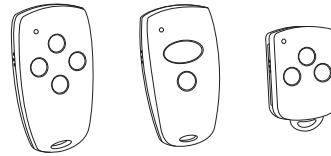

FCC Certified: This device complies with Part 15 of the FCC rules. Operation is subject to the following two conditions: (1) this device may not cause harmful interference, and (2) this device must accept any interference received, including interference that may cause undesired operation. Changes or modifications not expressly approved by the party responsible for compliance could void the user's authority to operate the equipment.

Fig. 40

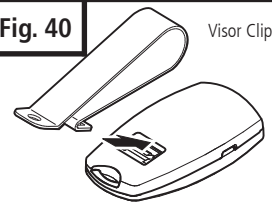

Fig. 41

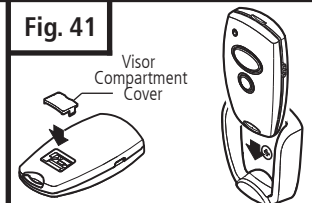
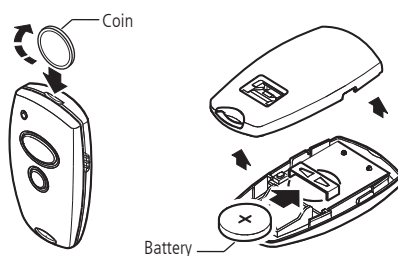

Fig. 42





## 14. OPERATION OF YOUR OPERATOR

Your operator can be activated via any of the following, depending on which accessories your opener system has:

- Remote Control Transmitter
- Wall Control Panel
- Keyless Entry (optional accessory)

### REMOTE CONTROL TRANSMITTER:

- To open or close garage door, press and hold button (Transmitter has an indicator light that will illuminate). See Fig. 43A. When garage door begins to move, release button.
- To stop garage door during travel, press and hold button until door stops, then release button.
- To resume garage door travel after stopping, press button again. Door begins to move in the opposite direction.

### WALL CONTROL PANEL:

- The Door Pushbutton will light when Wall Control properly connected (if it does not light up, review section 8-12 "Install Wall Control" on page 14).  
To open or close garage door, press and hold Illuminated Door Pushbutton. See Fig. 44. When garage door begins to move, release button.  
To stop garage door during travel, press and hold button until door stops, then release button.  
To resume garage door travel after stopping it, press button again. Door begins to move in the opposite direction.
- The Light On / Off button can be used to turn lights on or off.

**NOTE: The Light On / Off button must be pressed twice, in order to turn the operator light(s) off after a door cycle (activation).**

When using the light On / Off button, the automatic timer is ignored, and the lights will remain on until the button is pressed again, or until the operator is activated and the automatic timer begins again.

- The Lock/Vacation button can be used to lock out all remote control transmitters. The door can still be activated by wall control panel or keyless entry system. Press and hold Lock/Vacation button for 2-3 seconds. Release button. Illuminated Door Pushbutton will flash continuously while lock mode is active. To unlock opener, press and hold Lock/Vacation button for 2-3 seconds.

### OPERATOR LIGHTS:

- The amount of time that the operator light(s) are "on" can be adjusted. Please refer to level 5 menu 4 in the "Advanced Settings"
- Lights will come on whenever operator is activated. The default factory setting for the light to stay "on" is 4 minutes and 15 sec., or until the Light On / Off button on the wall control panel is pressed, whichever is sooner.
- Lights can be turned on and off manually as described under operation of wall control panel.
- Lights will flash when the operator senses an obstruction either detected by the internal safety system or the photo eye sensors. To stop lights from flashing, remove obstruction and operate door normally. The fault light indicator will flash for the set light time "on" factory default setting of 3 minutes maximum.

Fig. 43

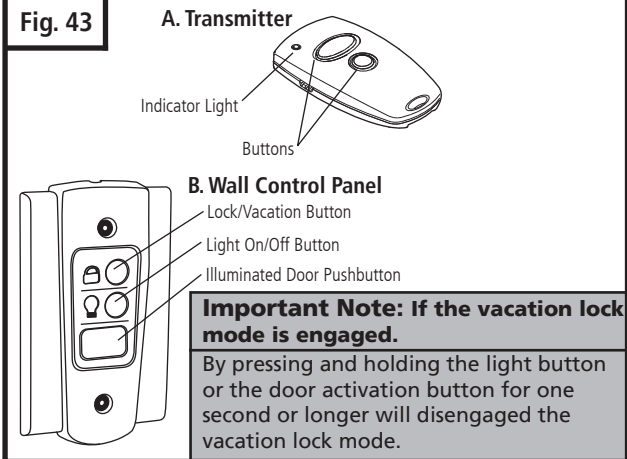
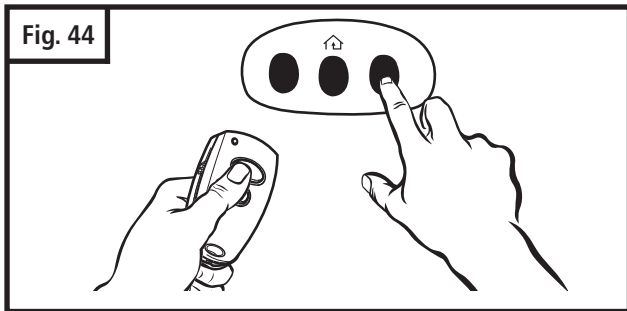

Fig. 44



## 15. HOMELINK® TRANSCIVER

Before you can use your car's HomeLink® device to open a garage door you must transfer an active code from the transmitter to the HomeLink® Universal transceiver. (Reference - HomeLink® Manual) (See Fig. 44)

- Clear memory in HomeLink® transceiver per manufacturer instructions.
- Make sure the door path is clear and the door is in the line of site at all time during the set up.
- Start the programming sequence by pressing the transmitter button and the HomeLink® transceiver button on console simultaneously. Follow manufacturer instructions to complete programming sequence. **No learn button on the operator is required to be pressed.**
- Repeat steps above for the other channels available.

## 16. TEST SAFETY REVERSAL

The safety reversal function of your operator is an extremely important feature of your operator. Testing this function ensures the correct operation of your operator and door.

The reversal system test should be performed:

- Once per month.
- Anytime the travel or force limits are reset or changed. Once the adjustments have been set and the door has been run up and down twice to “learn” the new settings, you must test the reversal system for proper operation.
- Place a 1-1/2" high rigid object (or a 2x4 board laid flat) on the floor directly in the path of the door. See Fig. 45.
- Start the door in the downward direction and watch what happens.
- When door contacts the object (or 2x4), it should stop, reverse, and automatically return to the fully opened position.
- If the door does not reverse, reset the down travel limit so that the door travels slightly further down in the closed direction. Then, retest the unit as described above.
- If the door still does not reverse, disconnect your operator and call a service person.

Fig. 45

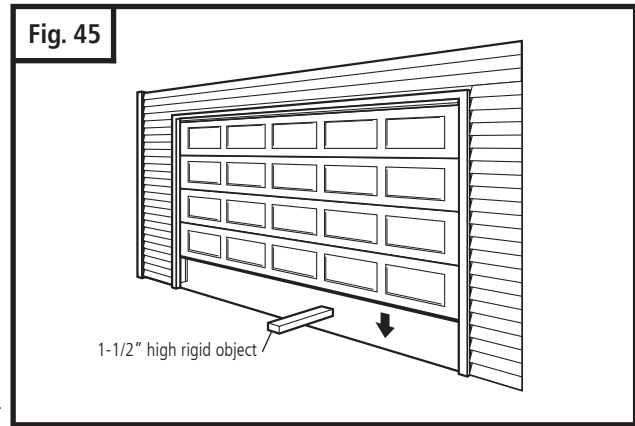

## 17. ALIGN AND TEST PHOTO EYE SENSORS

### PHOTO EYE SENSORS ALIGNMENT:

The photo eye sensors maintain an invisible, unbroken beam between each other. See Fig. 46.

**NOTE:** Sensor alignment must be done with the door in the closed position in order to ensure proper visibility of the sensor indicator LED.

- When the photo eye system is connected to the operator and the power is on, the green light on the transmitter sensor flashes, if the sensors are not aligned. When the sensors are aligned, the green light on the transmitter sensor will turn steady. See Fig. 46.
- Sensors must be installed parallel to the door plane and make sure the sensors are facing each other.

**AFTER THE SENSORS HAVE BEEN PROPERLY ALIGNED. MAKE SURE THAT THE SYSTEM OPERATION AND SAFETY TESTS OUTLINED BY THE GARAGE DOOR OPENER MANUFACTURER HAVE BEEN VERIFIED.**

### SAFETY TEST:

Photo eye sensors installed on opposite sides of your door opening are intended to detect a person or object in the path of the door and prevent the door from moving downward. The following steps will determine if the system is functioning properly:

- Open door using the operator's transmitter or wall control.
- Place a box or other object in the path of the door so it breaks the photo eye beam. See Fig. 48.
- Press and release the wall control button. The door should not move in the down direction. If this does not happen, disconnect operator and call for service.
- To reset operator, remove the obstruction and operate the door normally.
- If photo eye sensors are not aligned or are damaged, door can only be closed by pressing and holding wall control button until door is fully closed.

Fig. 46

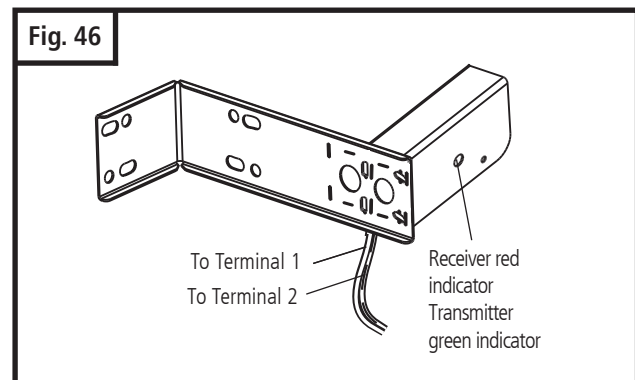

Fig. 47

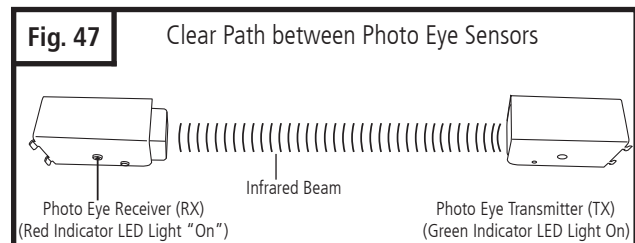
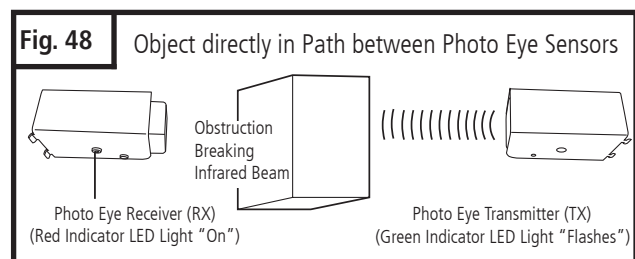

Fig. 48



## 18. APPLY LABELS TO INSIDE OF GARAGE

Several important safety and instruction labels are included with your operator package. These labels must be posted inside your garage where they can be easily seen by all. We recommend installing them in the location shown in Fig. 9 on page 7. To affix the labels, peel off the protective backing, and stick onto smooth, clean surface. If labels don't adhere well to surface, use tacks (wood door only) or additional adhesive to securely affix in place.  
DO NOT PAINT OVER ANY LABELS.

## 19. ATTACH OWNER'S MANUAL TO WALL

It is important that the manual be stored where it can be referred to later in case adjustments need to be made, and / or new controls or accessories added. Store the manual in a safe, easily accessible location. We recommend you use an envelope with an eyelet to store the manual in the garage on a nail or hook on the wall near the wall control.

## 20. IMPORTANT SAFETY INSTRUCTIONS

### IMPORTANT SAFETY INSTRUCTIONS

### **WARNING**

#### **TO REDUCE THE RISK OF SEVERE INJURY OR DEATH:**

1. **READ AND FOLLOW ALL WARNINGS AND INSTRUCTIONS CAREFULLY.**
2. Never let children operate or play with door controls. Keep the remote control away from children.
3. Always keep the moving door in sight and away from people and objects until it is completely closed. **NO ONE SHOULD CROSS THE PATH OF THE MOVING DOOR.**
4. NEVER GO UNDER A STOPPED, PARTIALLY OPEN DOOR.
5. Test door operator monthly. The garage door **MUST** reverse on contact with a 1-1/2" (40mm) high object (or a 2x4 laid flat) on the floor. After adjusting either the force or the limit of travel, retest the door operator. Failure to adjust the operator properly may cause severe injury or death.
6. If possible, use the emergency release only when the door is closed. Use caution when using this release with the door open. Weak or broken springs may allow the door to fall rapidly, causing severe injury or death.
7. **KEEP GARAGE DOORS PROPERLY BALANCED.** See Garage Door Owner's Manual. An improperly balanced door could cause severe injury or death. Have a qualified service person make repairs to cables, spring assemblies, and other hardware.
8. Disconnect the electrical power to the garage door operator before making any repairs or removing the housing cover.
9. **SAVE THESE INSTRUCTIONS** for future safety, adjustment, and maintenance purposes.

## 21. TENSION ADJUSTMENT

Your preassembled rail comes with the tension adjusted to factory specifications. There should be no need for further adjustment. However, if exposed or subjected to unusually harsh operating conditions, the tension may need to be readjusted during the life of the opener.

### CHECK PROPER TENSION (Fig. 49):

- Release trolley from belt or chain, then examine the setting of the tension adjustment at the header end of the rail.
- Proper tension is set when the tension nut is tightened just enough so that the washer will be spaced approximately 21mm or 53/64" from the stationary rail end-stop arch.
- If the gap between the washer and the rail end-stop arch is too big or too small, the tension needs to be adjusted.

### ADJUST THE TENSION:

- To increase the tension and tighten the belt or chain, turn the tension nut clockwise with 7/16" wrench until the washer is spaced properly from the rail end-stop arch. See Fig. 50.
- Once the washer is spaced correctly, any additional tightening will overtighten the belt or chain and may cause damage to the system.
- To loosen the tension, turn nut counterclockwise.
- Reattach trolley.

## 22. RAIL LENGTH ADJUSTMENT

### FOR PROFESSIONAL INSTALLERS ONLY

If your particular installation calls for a shorter rail than the standard length provided, it is possible to shorten the rail.

**NOTE:** Shortening rail too much may result in door travel length reduction and door not opening fully. This depends on door size and configuration. Carefully plan all such modifications before proceeding. THIS PROCEDURE SHOULD BE PERFORMED ONLY BY A PROFESSIONAL INSTALLER FULLY FAMILIAR WITH THIS TYPE OF OPENER SYSTEM.

### TO SHORTEN BELT RAIL LENGTH:

- Loosen belt tension as much as possible.
- Remove screws from sprocket holder and rail end-stop.
- Slide belt and all rail parts out of rail from header end. See rail exploded view, Fig. 51 on p. 29, for disassembly details.
- Measure and cut off excess rail from header end.
- Using rail end-stop as a guide, mark and drill a 3/16" hole for rail end-stop screw.
- Disassemble connector to expose free ends of belt.
- Using the same measurement as the excess rail length, cut the same amount off BOTH free ends of the belt.
- Reassemble belt connector, and slide all rail parts into rail from header end according to original assembly (Fig. 49).
- Tension belt properly (Fig. 49).
- Check rail for proper assembly and operation by manually moving trolley from end to end with trolley connected to belt.

Fig. 49

### Proper Tension Adjustment

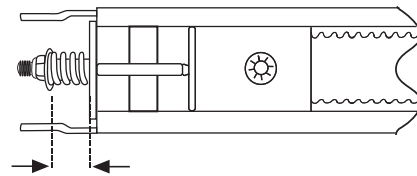

Proper Space 21mm + 0.5 or approximately (53/64")

Fig. 50

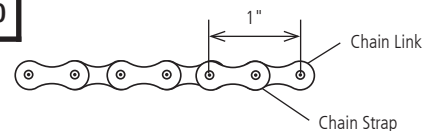

### TO SHORTEN CHAIN RAIL LENGTH:

- Loosen chain tension as much as possible.
- Remove screws from sprocket holder and rail end-stop.
- Slide chain and all rail parts out of rail from header end. See rail exploded view, Fig. 52 on p. 29, for disassembly details.
- Measure and cut off excess rail from header end by 1" increment only.
- Using rail end-stop as a guide, mark and drill a 3/16" hole for rail end-stop screw.
- Disassemble connector to expose free ends of chain.
- Using the same measurement as the excess rail length, remove the same amount off chain links and chain straps from BOTH free ends of the chain (Fig. 50).
- Reassemble two piece connector and slide chain and all rail parts into rail from header end according to original assembly (Fig. 49).
- Tension chain properly (Fig. 49).
- Check rail for proper assembly and operation by manually moving trolley from end to end with trolley connected to chain.

## 23. RAIL ASSEMBLY PARTS

**Fig. 51**

### Belt Rail Assembly

Model#: M13-807B (7' Door) M13-808B (8' Door) M13-810B (10' Door)

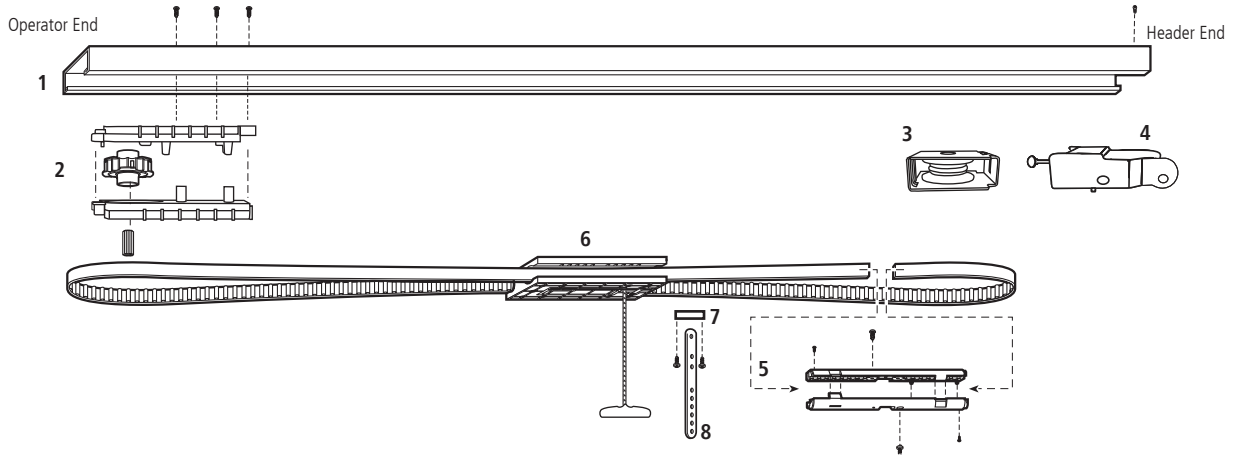

Item Part #	Description	Item Part #	Description
1. ———	Rail	6. 91569	Trolley assembly (7' Door)
2. 89687	Sprocket holder assembly	91570	Trolley assembly (8' & 10' Door)
97484	Shaft adapter	7. 98886	Pin
3. 95358	Roller holder assembly	8. 8030735	Straight door arm
4. 91566	Rail end assembly		
5. 8030196	Belt connector		

**Fig. 52**

### Chain Rail Assembly

Model#: M13-807C (7' Door) M13-808C (8' Door) M13-810C (10' Door)

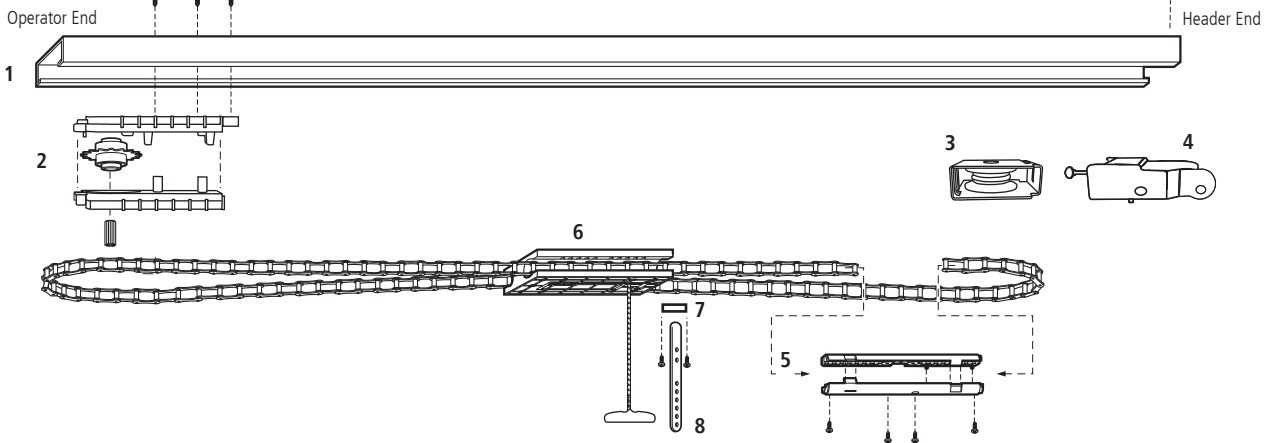

Item Part #	Description	Item Part #	Description
1. ———	Rail	6. 91569	Trolley assembly (7' door)
2. 8030339	Sprocket holder assembly	91570	Trolley assembly (8' & 10' Door)
97484	Shaft adapter	7. 98886	Pin
3. 95358	Roller holder assembly	8. 8030735	Straight door arm
4. 91566	Rail end assembly		
5. 8030234	Chain connector		

## 24. ACCESSORIES

Accessories are available from your dealer. If you have difficulty locating available accessories, please contact us directly at 1-888-622-2489 or visit our website at [www.marantecamerica.com](http://www.marantecamerica.com).

Fig. 53

### Mini & Micro Transmitters

(Battery and visor clip included)

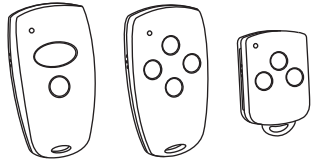

M3-2312 M3-2314 M3-3313

### MINI Transmitter Mounting Plate



ML-920

### Wall Control Panel

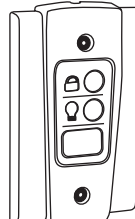

M3-543

### Rail Support Bracket

(For 10' doors and higher)

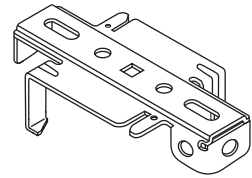

P/N: 71865

### Photo Eye Safety System

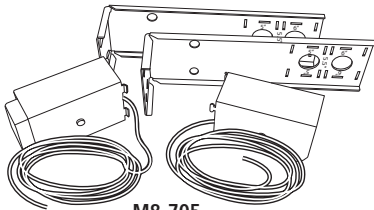

M8-705

### Wire Holder Kit

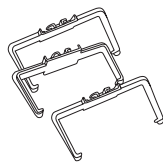

P/N: 86141

### Extension Bracket Kit

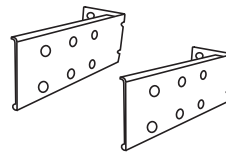

P/N: 85678

### Detachable Power Cord



P/N: 102807

### Wireless Keyless Entry System M3-631

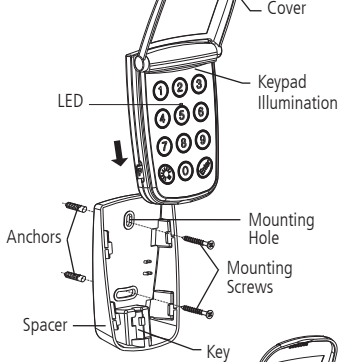
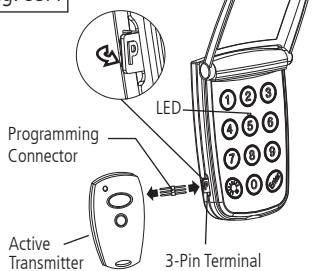
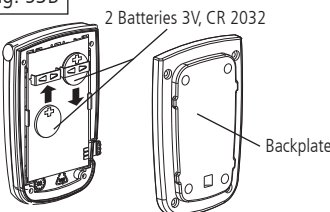

Fig. 53A



**Make sure the programming connector is inserted all the way into the programming port.**

Fig. 53B



### SETTING UP YOUR PERSONAL IDENTIFICATION NUMBER (PIN) AND TRANSFERRING THE CODE

- Open the terminal area and connect the Keyless Entry System to the active transmitter using the programming connector (see Fig. 53A).
- Press and hold the transmitter button you use to open and close your garage door. On the Keyless Entry System, press the ENTER button. The keypad illumination turns on.
- Input any new 4-digit PIN of your choice. Press the ENTER button again. Keep the transmitter button pressed until the LED on the Keyless Entry System blinks rapidly.
- The Keyless Entry System has now learned the code from the transmitter, and stored it under the PIN that you entered. Remove the programming connector and close the terminal area.

### USING KEYLESS ENTRY SYSTEM:

#### 1. STORING MORE THAN 1 PIN FOR SAME CODE

- It is possible to store up to 3 different PINs for the same code for use by different individuals.
- Follow the same steps as described above. Repeat the procedure for each PIN, using the same transmitter each time. This will store the same code under 3 different PINs.

#### 2. STORING A TEMPORARY PIN

- A temporary PIN can be stored which will permit operation for 3 times only.
- Press and hold "button 1" on the keypad for 3 seconds until the LED on keypad blinks rapidly.
- Enter a temporary 4-digit PIN of your choice followed by the ENTER button.
- The LED on the keypad will illuminate for 2 seconds, then the Keyless Entry System will shut off and the keypad illumination will go out. Keyless Entry System is now ready for use again.
- To use Keyless Entry System with the newly stored temporary PIN, enter the 4-digit temporary PIN followed by the ENTER button. This can be done 3 times, after which the temporary PIN will be automatically erased.

#### 3. STORING MORE THAN 1 CODE TO CONTROL MORE THAN 1 GARAGE DOOR OPERATOR

- The Keyless Entry System may be used to control up to 3 different garage door operators, each with a different code.
- For code #1 and #2 follow the same procedure as described in Step A. Enter a different PIN for each code.

- For code #3 enter factory pre-programmed PIN 1-2-3-4, and then change this PIN to new PIN of your choice. Follow steps as described below.

- To use the Keyless Entry System to open or close a specific door, simply enter the corresponding PIN for that door followed by pressing the ENTER button.

#### 4. CHANGING THE PIN

- Press and hold "button 0" on the keypad for 3 seconds until the LED on the keypad blinks rapidly.
- Enter the PIN which is to be changed followed by pressing the ENTER button.
- Enter the new 4-digit PIN followed by pressing the ENTER button. The LED on the keypad will turn on (no flashing) for 2 seconds.
- The Keyless Entry System is now ready for use again with the new pin (Old PIN is no longer valid).

#### 5. CLEARING THE MEMORY

- Press and hold the LIGHT button on the keypad for 3 seconds until the LED on the keypad blinks rapidly.
- Enter the PIN 9-9-9-9.
- Release LIGHT button. The memory is cleared. The LED on the keypad will illuminate for 2 seconds.

**NOTE: After clearing the memory, the Keyless Entry System defaults to a random code and the PIN 1-2-3-4.**

#### 6. REPLACING THE BATTERIES (Fig. 53B)

- Turn counterclockwise the key on the bottom of the spacer and remove the Keyless Entry System from the spacer.
- Release the backplate of the Keyless Entry System.
- Remove old batteries.
- Replace with 2 new 3V batteries, CR 2032. Match polarity designation. Test operability. (Keyless Entry System is designed to remember all previously programmed codes and PINs while battery is being replaced).
- Replace the backplate.

*For protection of keypad, keep cover closed when not in use.*

## 25. TROUBLESHOOTING — FOR PROFESSIONAL INSTALLER ONLY

The operator displays the system fault(s) automatically one at a time as follows:

### System Fault Display: (Example - Error Code 7)

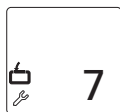

Fault 1



**Note:** ■ The last system fault code can be viewed by pressing the “P” button once. To return to operation mode press “-” or “+” button.

FAULT DISPLAY	CODE	PROBLEM	SOLUTION
	7	<b>NOTICE:</b> ■ If no buttons are pressed within 120 seconds, the programming mode terminates automatically. ■ OPEN and CLOSED door positions programmed without passing the reference point.	
	8	■ Adjustments setting interrupted before completion. ■ Detective reference switch.	■ Door can be operated normally. Recheck adjustments if adjustment settings were not completed. Refer to page 18. ■ Have operator serviced.
	9	■ Rational speed sensor impulse not present, operator system is obstructed.	■ Have operator serviced.
	10	■ The door does not move easily or is obstructed.	■ The maximum driving power has been set too low. Have maximum driving power checked by specialist dealer.
	11	■ Excess travel stop.	■ Have operator serviced.
	15	■ Photo eye sensors not connected properly. ■ Photo eye sensors not aligned. ■ Obstruction in the door path (photo eye beam broken).	■ Check photo eye sensors wiring and connections. ■ Realign photo eye sensors. ■ Remove obstruction from door path.
	16	■ The current sensor for the automatic cut-out is defective.	■ Have operator serviced.
	26	■ Operator system overloaded.	■ Have the outlet assigned for the operator and/or supplied power checked.
	28	■ Door movement too stiff or irregular. ■ Door blocked. ■ Operator operating sensitivity set too sensitive (low).	■ Check door for obstructions, proper manual operation, proper balance, or broken springs. Clear obstructions or have door serviced, if needed. ■ Have the operating sensitivity settings checked by an authorized dealer/installer.
	30	■ MS bus fault	■ Reset the bus modules ■ Have the connected bus modules checked.

## 25. TROUBLESHOOTING — FOR PROFESSIONAL INSTALLER ONLY (cont'd)

FAULT DISPLAY	CODE	PROBLEM	SOLUTION
	33	<ul style="list-style-type: none"><li>■ Rise in temperature.</li></ul>	<ul style="list-style-type: none"><li>■ Allow the operator to cool down.</li></ul>
	35	<ul style="list-style-type: none"><li>■ Electronic defect.</li></ul>	<ul style="list-style-type: none"><li>■ Have operator serviced</li></ul>



## 26. MAINTENANCE AND ADJUSTMENTS

To ensure continued safe operation and extended life of your operator system, periodic checking for proper operation is necessary. Occasional maintenance and readjustment of your system may also be needed.

### MONTHLY:

- Check reversal system by performing "safety reversal test" described in this manual.
- Check proper operation of door by manually moving door open and closed. If door binds or sticks, or is out of balance call for garage door service.
- Check and test photo eye safety system as described in this manual.

### ONCE EVERY YEAR

- Keep door rollers, hinges, and bearings properly lubricated by following recommended door instructions or contacting a door service company in your area.

### AS NEEDED:

- Readjust operator travel limits and force settings as necessary — due to cold weather, normal wear of door, etc. For any periodic adjustments needed refer to this manual.
- Check and readjust belt tension, if necessary, in the unlikely event that it loses its proper tension during the life of the operator. Always check the reversal system after any adjustment of travel limits or forces. A door operator that is not checked could possibly be out of adjustment and be dangerous.

## 27. LIMITED PARTS WARRANTY

**MARANTEC AMERICA CORPORATION**  
**Synergy Professional Series Residential Garage Door Opener System**  
**Limited Parts Warranty**  
**Synergy 260 and Synergy 270 Models**

The Synergy 260 System Limited Warranty is 1 year for parts and a Limited Lifetime\* Warranty for the motor, gear assembly and rail system.

The Synergy 270 System Limited Warranty is 2 years for parts and a Limited Lifetime\* Warranty for the motor, gear assembly and rail system.

Marantec America Corporation warrants the LED Lighting System, the Battery Backup System (where applicable) and Accessories for 1 year.

**THE LIMITED LIFETIME\* PORTION OF THE WARRANTY IS FOR AS LONG AS THE ORIGINAL PURCHASER OF THE MARANTEC SYSTEM OWNS HIS OR HER HOME OR 20,000 SYSTEM OPEN & CLOSE CYCLES, WHICHEVER COMES FIRST.**

**Limited Warranty Coverage: THE LIMITED LIFETIME\* WARRANTY IS FOR AS LONG AS THE ORIGINAL PURCHASER OF THE MARANTEC SYSTEM OWNS HIS OR HER HOME, OR 20,000 SYSTEM OPEN & CLOSE CYCLES, WHICHEVER COMES FIRST.** This Warranty applies, upon purchase from a Marantec reseller and installation by a professional installer and registration of the product within 14 days of the date of installation of the product, (or within 30 days of closing on a new home from a developer) to any defect in materials or workmanship in the Marantec product parts or components from personal, normal, household use in compliance with the Owner's Manual for a period of 1 year for the Synergy 260 System and for a period of 2 years for the Synergy 270 System from the date of installation (or closing date) on its parts and, for the Limited Lifetime\* portion of this Warranty on the motor and rail system and belt, for as long as the original retail purchaser owns his or her home or 20,000 system open & close cycles, whichever comes first. Marantec warrants this Garage Door Opener system to its first retail, consumer purchaser only. This is not a commercial product. Marantec disclaims any and all warranties in the event that the product is obtained from a source which is not a Marantec authorized reseller or if the product is not installed by a professional installer. "Grey market" purchases are not warranted or recognized in any manner whatsoever. This is not a "do it yourself" product. There is no warranty if the seal on the Marantec carton is broken at the time of sale, delivery or installation by a professional installer. No "aftermarket" installation, alteration, opening of the housing or cases, modification or repairs are recognized or warranted. Any of the foregoing conduct voids all warranty provisions. This warranty is for parts only and is not for any service call(s) or labor in connection with the repair or replacement of the unit or its parts. Parts will only be shipped to a Marantec authorized reseller.

## 27. LIMITED PARTS WARRANTY (cont'd)

**Marantec Accessories:** Marantec accessories include such items as transmitters, wall controls, photo eye systems, and wireless/keyless entry systems. These are warranted to be free from defects in materials or workmanship for 1 year from the date of installation or closing. At Marantec's sole option, Marantec may elect to replace the accessory with new or reconditioned parts, components or units utilizing product of the same or similar design available at that given time. **WITH RESPECT TO ACCESSORIES, ALL OTHER WARRANTIES, INCLUDING FITNESS FOR PARTICULAR PURPOSE AND MERCHANTABILITY ARE SPECIFICALLY DISCLAIMED AND THE LIMITED WARRANTY SET FORTH BELOW IN BOLD TYPE IS HEREIN INCORPORATED BY REFERENCE.**

**LED Lighting System and Battery Backup System:** Marantec warrants the parts of the LED Lighting System, including its lighting bar and LEDs and lens covers and the Battery Backup System (where applicable) including its charging system and battery for 1 year from the date of installation or closing, if a new home purchased from a developer. These are warranted to be free from defects in materials or workmanship for 1 year from the date of installation or closing. At Marantec's sole option, Marantec may elect to replace the System with new or reconditioned parts, components or units utilizing product of the same or similar design available at that given time. **WITH RESPECT TO THE LED LIGHTING SYSTEM AND BATTERY BACKUP SYSTEM, ALL OTHER WARRANTIES, INCLUDING FITNESS FOR PARTICULAR PURPOSE AND MERCHANTABILITY ARE SPECIFICALLY DISCLAIMED AND THE LIMITED WARRANTY SET FORTH BELOW IN BOLD TYPE IS HEREIN INCORPORATED BY REFERENCE.**

Marantec does **not** warrant batteries (except the Battery Backup System battery above) light bulbs, sensors or LED bulbs (except the LED Lighting System LEDs above). Unauthorized repairs or repair parts, installations, commercial use, damage while in transit, defects or damage resulting from power washing, water or moisture exposure, or accidents, power failure and surges, resulting from alterations, lack of proper maintenance, unauthorized repair or modification of the product, opening of housing or case, misuse or abuse of the product, fire, flood, acts of God, damage to doors, tracks, springs, hardware or the residence, its contents and vehicles, other property or persons or other failures due to failure to follow the recommendations of the Owner's Manual are not warranted. This warranty applies only to Marantec systems purchased from authorized Marantec retail sellers and used in the United States, its Territories or Canada. Marantec make no warranties outside the United States, its Territories or Canada.

**Marantec Commitment:** If Marantec determines the product parts to be defective in materials or workmanship, then Marantec will supply parts for the repair or replacement of the defect to the Marantec authorized professional installer at no cost to you. You must pay for the service call and labor for installation of the part(s) determined to be defective by Marantec. At Marantec's sole option, Marantec may elect to replace the part(s) with new or reconditioned parts, components or units utilizing product of the same or similar design available at that given time.

**THIS LIMITED WARRANTY IS IN LIEU OF ANY OTHER WARRANTIES, EXPRESS OR IMPLIED, INCLUDING ANY IMPLIED WARRANTIES OF MERCHANTABILITY OR FITNESS FOR A PARTICULAR PURPOSE, OR OTHER WARRANTIES IMPLIED BY STATUTE, AND OF ANY OTHER OBLIGATIONS OR LIABILITY ON THE PART OF MARANTEC AMERICA CORPORATION. THIS LIMITED WARRANTY DOES NOT COVER NON-DEFECT DAMAGE CAUSED BY IMPROPER INSTALLATION, OPERATION OR CARE AND MAINTENANCE, INCLUDING BUT NOT LIMITED TO ABUSE, MISUSE, POWER SURGE, FAILURE TO PROVIDE REASONABLE AND NECESSARY MAINTENANCE OR ANY ALTERATIONS TO THIS PRODUCT. LABOR CHARGES FOR DISMANTLING OR REINSTALLING A REPAIRED OR REPLACED UNIT ARE EXCLUDED.**

**UNDER NO CIRCUMSTANCES SHALL MARANTEC AMERICA CORPORATION BE LIABLE FOR CONSEQUENTIAL, INCIDENTAL OR SPECIAL DAMAGES ARISING IN CONNECTION WITH THE USE OR INABILITY TO USE THIS PRODUCT OR THE PREMISES IN WHICH IT IS UTILIZED. IN NO EVENT SHALL MARANTEC AMERICA CORPORATION INCUR LIABILITY FOR BREACH OF WARRANTY, BREACH OF CONTRACT, NEGLIGENCE OR STRICT LIABILITY IN EXCESS OF THE COST OF THE PRODUCT COVERED HEREBY. NO PERSON IS AUTHORIZED TO ASSUME, FOR MARANTEC AMERICA CORPORATION, ANY OTHER LIABILITY OR MAKE ANY MODIFICATIONS OR EXTENSIONS TO THE WARRANTY OF THIS PRODUCT. THIS LIMITED WARRANTY MAY NOT BE TRANSFERRED OR ASSIGNED.**

## 28. WARRANTY LIMITATIONS, CLAIMS AND SERVICE:

This Limited Warranty is the one which Marantec gives on this product and sets forth all of its responsibilities regarding the Marantec product. There are no other express or implied warranties. Installation by unauthorized personnel or use of unauthorized parts or accessories could cause improper operation and even create dangerous conditions and voids all warranties. This could void the UL Safety Approval of the product and constitute a safety hazard.

This Limited Warranty contains the entire warranty on the product. All discussions, representations or negotiations between the consumer and the retail seller are merged into this Limited Warranty, and there are no understandings or warranties other than those herein. None of the terms of the Limited Warranty shall be waived or modified to any extent, except by a written instrument signed and delivered by Marantec's Corporate Officer.

This Limited Warranty is being delivered in Gurnee, Illinois, USA and is intended to be performed in the State of Illinois and shall be construed and enforced in accord with the laws and statutes of the State of Illinois without regard to or application of its rules on the conflict of laws, with the proper venue for any disputes being that of Marantec's registered office in Illinois or its corporate offices in Gurnee, Illinois, whichever Marantec elects. Marantec expressly disclaims the application to this Limited Warranty of the 1980 United Nations Convention on the International Sale of Goods. Any interpretation of this Limited Warranty shall be conducted in English and no other language. **ALL CLAIMS AND CAUSES OF ACTION OF ANY NATURE AGAINST MARANTEC AMERICA CORPORATION SHALL BE BROUGHT WITHIN 1 YEAR OF THE DATE OF DISCOVERY OF THE CLAIM.**

In the event any action or proceeding or claim is asserted or brought against Marantec, if Marantec prevails, then Marantec shall be entitled to recover all costs and expenses, including the actual fees of its attorneys and expert or professional witnesses incurred in connection with such action or proceeding or claim.

This Limited Warranty becomes valid only upon the receipt of "Payment in Full" by Marantec from the Marantec reseller and upon receipt of "Payment in Full" by the Marantec reseller from the end user. This Limited Warranty is null and void if the System is not installed within 24 months of the date of manufacture as marked on the product housing. This Limited Warranty is void outside the United States, its Territories and Canada.

Whenever possible, each provision of this Limited Warranty shall be interpreted in such a manner as to be effective and valid under applicable Illinois law. If any provisions of this Limited Warranty are prohibited or invalidated under applicable law, then such provisions shall only be ineffective to the extent of such prohibition or invalidity, without invalidating the remaining provisions of this Limited Warranty.

Some jurisdictions do not allow the exclusion or limitation of consequential, incidental or special damages, so the above limitations or exclusions may not apply to you. This Limited Warranty gives you specific legal rights and you may also have other rights which vary from state to state.

## 29. REGISTRATION:

After installation by your professional installer, this Warranty becomes effective upon registration at the Marantec web site: [www.marantecamerica.com](http://www.marantecamerica.com). If you do not have access to the internet, you must call the Marantec Customer Service number below and register by telephone with the Customer Service Representative at 888-622-2489.

## 30. FOR WARRANTY SERVICE:

Contact your professional installer for all service. Service by anyone other than a professional installer voids this warranty. If you cannot locate your installer, please telephone the Marantec Customer Service Representative at the number above or contact us through the telephone number on our web site.

