

# **LOTOS TIG200-DC**

---

## **TIG/Stick Welder**



[www.uwelding.com](http://www.uwelding.com)

# CONTENTS

<b>1. Contents</b>	<b>1</b>
<b>2. Safety warning</b>	<b>2</b>
<b>3. Machine description</b>	<b>3</b>
<b>4. Technical parameters table</b>	<b>4</b>
<b>5. Installation instruction</b>	<b>5</b>
<b>6. Panel function instruction</b>	<b>7</b>
<b>7. Operation instruction</b>	<b>8</b>
<b>8. Notes or preventive measures</b>	<b>9</b>
<b>9. Questions to be run into during welding</b>	<b>10</b>
<b>10. Maintenance</b>	<b>11</b>
<b>11. Before checking</b>	<b>12</b>

---

## SAFETY WARNING

---



**On the process of welding or cutting, there will be any possibility of injury, so please take protection into consideration during operation. More details please review the Operator Safety Guide, which complies with the preventive requirements of the manufacturer**

### **Electric shock——may lead to death !!**

- Set the earth fitting according to applying standard.
- It is forbidden to touch the electric parts and electrode when the skin is naked, wearing wet gloves or clothes.
- Make sure you are insulated from the ground and the workshop.
- Make sure you are in safe position.

### **Gas——may be harmful to health!**

- Keep your head out of the gas.
- When arc welding, air extractor should be used to prevent from breathing gas.

### **Arc radiation——Harmful to your eye and burn your skin.**

- Use suitable helmet and light filter, wear protective garment to protect eye and body.
- Use suitable helmet or curtain to protect looker-on.

### **Fire**

- Welding spark may cause fire, make sure the welding area no tinder around.

### **Noise——extreme noise harmful to ear.**

- Use ear protector or others means to protect ear.
- Warn that noise harmful to hearing if looker-on around.

### **Malfunction——When trouble, count on the professionals**

- If trouble in installation and operation, please follow this manual instruction to check up.
- If fail to fully understand the manual, or fail to solve the problem with the instruction, you should contact the suppliers or our service center for professional help.



### **CAUTION!**

**Creep age-protecting switch should be added when using the machine !!!**

---

## MACHINE DESCRIPTION

---

Welding machine is a rectifier adopting the most advanced inverter technology.

The development of inverter gas-shielded welding equipment profits from the development of the inverter power supply theory and components. Inverter gas-shielded welding power source utilizes high-power component MOSFET to transfer 50/60HZ frequency up to 100KHZ, then reduce the voltage and commutate, and output high-power voltage via PWM technology. Because of the great reduce of the main transformer's weight and volume; the efficiency increases by 30%. The appearance of inverter welding equipment is considered to be a revolution for welding industry.

Welding power source can offer stronger, more concentrated and more stable arc. When stick and work piece get short, its response will be quicker. It means that it is easier to design into welding machine with different dynamic characteristics, and it even can be adjusted for specialty to make arc softer or harder.

TIIG welding machine is easy for arc initiation and has the functions of arc initiation current, arc stop current, welding current, basic value current, current ascending time, current descending time, gas delay time, continuous adjustment. What's more, pulse frequency and pulse duty can also be adjusted independently. It has the characteristics of automatic control of arc initiation, arc stop and stable arc, which make the best result for shape and inner quality of the welding surface. Its exclusive design is specially suitable for bicycle industry.

The machine can be for multi-use, and can weld stainless steel, carbon steel, copper and other color metal, and also can use for traditional electric welding. Its transfer efficiency is above 85%.

The machine is suitable for welding stainless steel, mild steel, aluminum, and other metal materials.

The machine accessories and consumables can be purchased on [www.uwelding.com.au](http://www.uwelding.com.au) to order.



### **CAUTION!**

The machine is mainly used in industry. It will produce radio wave, so the worker should make fully preparation for protection.

## TECHNICAL PARAMETERS TABLE

model parameters	TIG 200-DC	
Input Power voltage (V)	110/220V $\pm$ 15%, 1-PH, 50/60Hz	
Frequency (HZ)	50/60	
	110V	220V
Rated input current (A)	TIG: 28A	TIG: 34A
	MMA: 42.8A	MMA: 47A
Rated output voltage (V)	TIG: 14.8V	TIG: 17.6V
	MMA: 24.8V	MMA: 28.4V
Rated output current (A)	TIG: 10~120	TIG: 10~190
	MMA: 30~120	MMA: 30~180
No-load voltage (V)	50-80	50-80
Arcing way	HF	
Duty cycle (%)	60	
Post gas time (S)	After descending 2/5S	
No-load loss (W)	40	
Efficiency (%)	80	
Power factor	0.73	
Insulation grade	F	
Housing	IP21	
weight (kg)	17	
Dimensions (mm)	485×395×360	

---

## INSTALLATION INSTRUCTION

---

The machine is equipped with power voltage compensation equipment. When power voltage moves between  $\pm 15\%$  of rated voltage, it still can work normally.

When use long cable, in order to prevent voltage from going down, bigger section cable is suggested. If cable is too long, it may affect the performance of the power system. So we suggest you to use configured length.

1. Make sure intake of the machine not blocked or covered, lest cooling system could not work.
2. Make good connection of shielded gas source. Gas supply passage includes cylinder, argon decompress flow meter and pipe. Connecting part of pipe should used hoop or other things to fasten, lest argon leaks out and air gets in.
3. Use inducting cable whose section is not less than  $6 \text{ mm}^2$  to connect the housing to the ground. The way is from the ground-connecting screw at the back to the earth device.
4. Correctly connect the arc torch or holder according to the sketch. When use MMA welding: Make sure the cable, holder and fastening plug have been connected with the ground. Put the fastening plug into the fastening socket at the “-”polarity and fasten it clockwise. When use pulse arc welding: Put the gas-electricity plug of the welding gun to the joint at the front panel, and fasten clockwise. Put the air switch on the gun to the relevant joint at the front panel, and fasten the screw.
5. Put the fastening plug of the cable to fastening socket of “+” polarity at the front panel, fasten it clockwise, and the earth clamp at the other terminal clamps the work piece.
6. According to input voltage grade, connect power cable with power supply box of relevant voltage grade. Make sure so mistake and make sure the voltage difference among permission range. After the above job, installment is finished and welding is available.
7. VRD Function: Protection against electric shock

When the welder is at MMA state, the output voltage is in 24 safety voltage. When it is in the short circuit, the welder can be tested by itself automatically. It can make the voltage up to 60V in order to start the arc and make the welder to work normally. When stopping welding, please post 3s-5s to keep the output voltage in 60V facilitate welding again to start the arc. When the welder doesn't work more than 5s, the output voltage will be descended to 24V to avoid that the operator is uncaredful to get an electric shock when using the welder or change the electric stick.

## When use MMA function

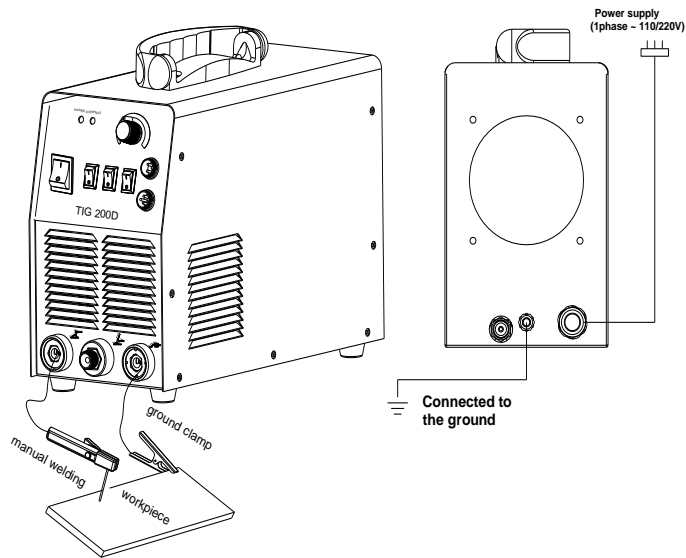

## When use TIG function

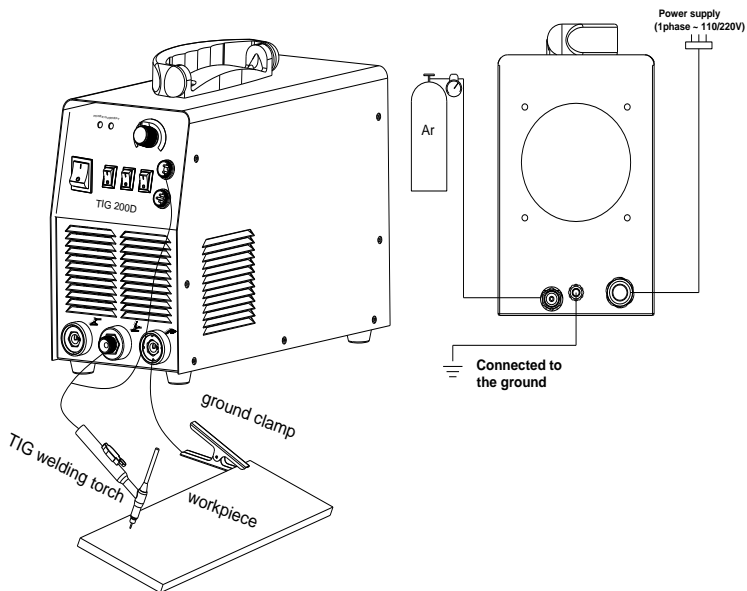

### warning !

Before connecting operation please make sure all the power is turned off. The right order is to connect the welding cable and ground cable to the machine first, and make sure they are firmly connected and then put the power plug to the power source.

# PANEL FUNCTION INSTRUCTION

## TIG 200-DC

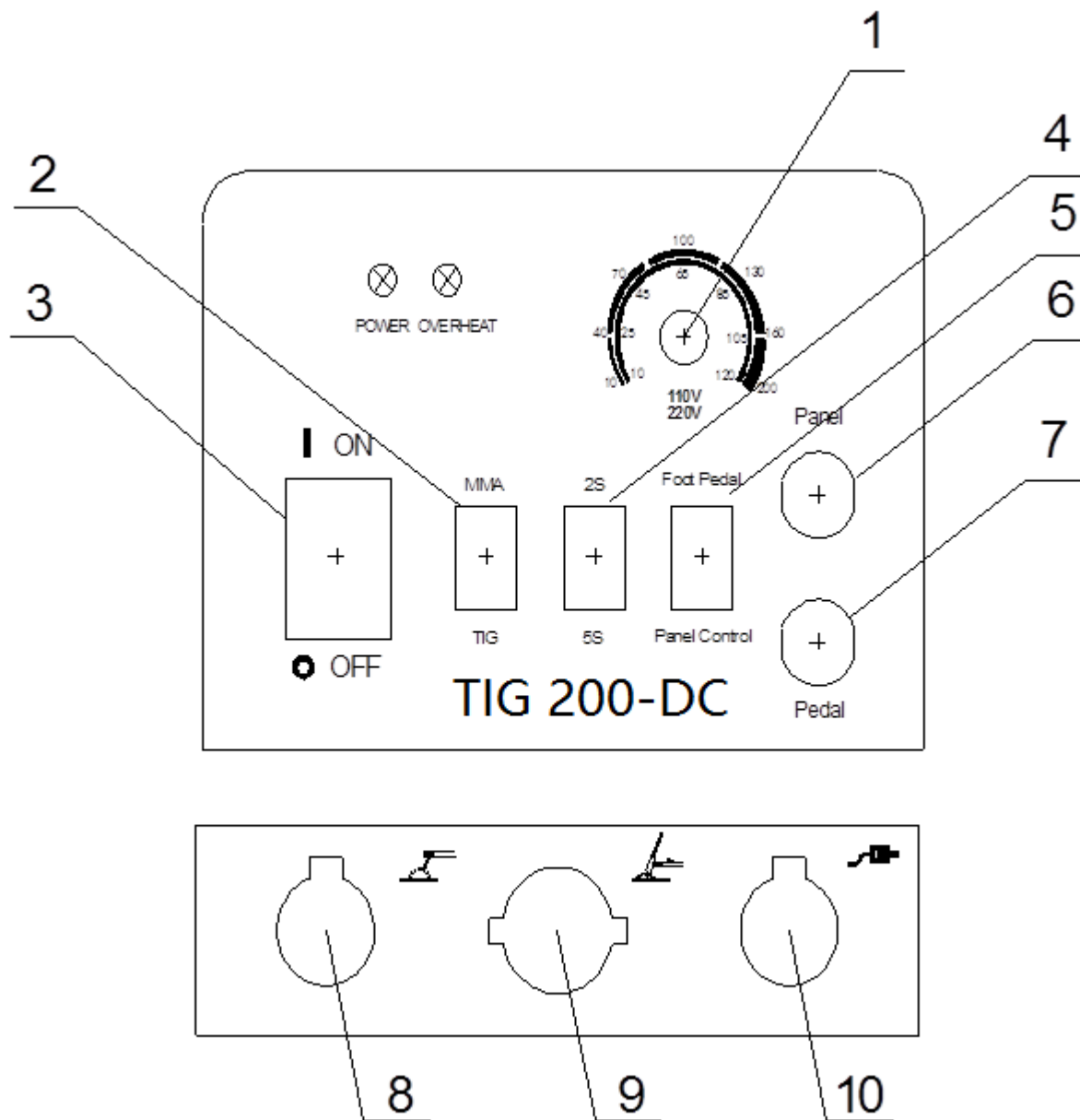

1	Welding current adjustment	6	TIG welding torch switch
2	MMA/TIG switch	7	Remote control socket
3	Power switch	8	Manual welding interface
4	2S/5S switch	9	TIG welding torch interface
5	Pulse frequency change-over switch	10	Ground clamp interface

The panel picture above is for reference only. If any difference with the real machine, please follow with the real machine.



---

## OPERATION INSTRUCTION

---

### TIG WELDING DESCRIPTION

1. Turn on the power switch at the front panel, digital current meter is normal, fan begins to rotate.
2. Open the valve of argon cylinder , adjust the volume of flow meter and make it is adequate to welding .
3. Press switch of torch, electromagnetic valve is started. Sound of HF arc striking can be heard, at the same time argon is flowing from torch burner. NOTES: When welding is first operated, user must press switch of torch several seconds and begin to weld until all of air is be drained out. When welding is over, argon will still flow out in several seconds in order to protect welding spot before cooled down .So torch must be kept welding place some time before arc has been extinguished.
4. Set suitable welding current and make sure welding current is adequate to thickness of workpiece and process demand.

### STICKING DESCRIPTION

- 1) It is 2-4 mm from welding tungsten electrode to workpiece, press control knob of torch, burn and strike arc, sound of HF arc-striking will be diminished. The welding machine can be operated now.
- 2) Open power switch of front panel, fan is beginning to work.
- 3) Make sure function switch of front panel is on “down” position that is sticking. Impulse changeover switch and knob of current down-slope time will not work.
- 4) Make sure welding current is adequate to thickness of work piece.



#### **warning :**

During welding, it is forbidden to pull off any plug or cable in use, or it will lead to life-threatening danger and sever damage of the machine.



### 1、 Environment

- 5) The machine can perform in environment where conditions are dry with a dampness level of max 90%.
- 6) Ambient temperature is between -10 to 40 degrees centigrade.
- 7) Avoid welding in sunshine or drippings.
- 8) Do not use the machine in environment where condition is polluted with conductive dust on the air or corrosiveness gas on the air.
- 9) Avoid gas welding in the environment of strong airflow.

### 2、 Safety norms

The welding machine has installed protection circuit of over voltage and current and heat. When voltage and output current and temperature of machine are exceeding the rated standard, welding machine will stop working automatically. Because that will be damaged to welding machine, user must pay attention as following.

#### **The working area is adequately ventilated !**

The welding machine is powerful machine, when it is being operated, it generated by high currents, and natural wind will not satisfy machine cool demands. So there is a fan in inter-machine to cool down machine. Make sure the intake is not in block or covered, it is 0.3 meter from welding machine to objects of environment. User should make sure the working area is adequately ventilated. It is important for the performance and the longevity of the machine.

#### 2) **Do not over load !**

The operator should remember to watch the max duty current (Response to the selected duty cycle).

Keep welding current do not exceed max duty cycle current.

Over-load current will damage and burn up machine.

#### 3) **No over voltage !**

Power voltage can be found in diagram of main technical data. Automatic compensation circuit of voltage will assure that welding current keep in allowable rangement. If power voltage is exceeding allowable rangement limited, it is damaged to components of machine. The operator should understand the situation and take preventive measures.

- 4) There is a grounding screw behind welding machine, there is grounding marker on it . Mantle must be grounded reliable with cable which section is over 6 square millimeter I order to prevent from static electricity and leaking.

- 5) If welding time is exceeded duty cycle limited, welding machine will stop working for protection. Because machine is overheated, temperature control switch is on “ON” position and the indicator light is red. In this situation, you don’t have to pull the plug, in order to let the fan cool the machine. When the indicator light is off, and the temperature goes down to the standard range, it can weld again.

---

## QUESTIONS TO BE RUN INTO DURING WELDING

---

Fittings, welding materials, environment factor, supply powers maybe have something to do with welding. User must try to improve welding environment.

### A、 Black welding spot

——Welding spot is not prevented from oxidizing .User may check as following :

1. Make sure the valve of argon cylinder is opened and its pressure is enough. argon cylinder must be filled up to enough pressure again if pressure of cylinder is below 0.5Mpa .
2. Check if the flow meter is opened and has enough flow .User can choose different flow according to welding current in order to save gas .But too small flow maybe cause black welding spot because preventive gas is too short to cover welding spot .We suggest that flow of argon must be kept min 5L/min.
3. Check if torch is in block .
4. If gas passage is not air-tight or gas is not pure can lower welding quality .
5. If air is flowing powerfully in welding environment ,that can lower welding quality .

### B、 Arc-striking is difficult and easy to pause

1. Make sure quality of tungsten electrode is high .
2. Grind end of the tungsten electrode to taper .If tungsten electrode is not grinded ,that will be difficult to strike arc and cause unstable arc .

### C、 Output current not to rated value

When power voltage departs from the rated value, it will make the output current not matched with rated value; When voltage is lower than rated value, the max output may lower than rated value.

### D、 Current is not stabilizing when machine is been operating

It has something with factors as following :

1. Electric wire net voltage has been changed .
2. There is harmful interference from electric wire net or other equipment .

### E、 When use MMA welding,too much spatter

1. Maybe current is too big and stick's diameter is too small;
2. Output terminal polarity connection is wrong, it should apply the opposite polarity at the normal technics, which means that the stick should be connected with the negative polarity of power source, and work piece should be connected with the positive polarity. So please change the polarity.

---

## MAINTENANCE

---



**CAUTION:**

Before Maintenance and checking, power must be turned off, and before Opening the housing, make sure the power plug is pulled off..

- 1、 Remove dust by dry and clean compressed air regularly, if welding machine is operating in environment where is polluted with smokes and pollution air, the machine need remove dust every month
- 2、 Pressure of compressed air must be inside the reasonable rangement in order to prevent damaging to small components of inter-machine.
- 3、 Check inter circuit of welding machine regularly and make sure the cable Circuit is connected correctly and connectors are connected tightly (especially insert connector and components). If scale and loose are found, please give a good polish to them, then connect them again tightly.
- 4、 Avoid water and steam enter into inter-machine, if them enter into machine, please dry inter-machine then check insulation of machine.
- 5、 If welding machine will not be operated long time, it must be put into packing box and store in dry environment.

## BEFORE CHECKING



### WARNING

Blind experiment and careless repair may lead to more problem of the machine that will make formal check and repair more difficult. When the machine is electrified, the naked parts contain life-threatening voltage. Any direct and indirect touch will cause electric shock, and severe electric shock will lead to death.

## TIG 200-DC CHECK FAULT



Faults	Resolvable Methods
Power indicator is not lit ,fan does not work and no welding output	<ol style="list-style-type: none"> <li>1. Power switch is out of work .</li> <li>2. Check if electrify wire net (which is connected to input cable )is in work. .</li> <li>3. Check if input cable is out of circuit .</li> </ol>
.Power indicator is lit ,fan does not work or revolve several circles ,no welding output	<ol style="list-style-type: none"> <li>1. Maybe connect wrong to 380V power cause machine is in protection circuit ,connect to 240V power and operate machine again .</li> <li>2. 240v power is not stable,(input cable is too slender)or input cable is connected to electrify wire net cause machine is in protection circuit .Add the section of cable and tighten input connector firmly .Close machine 2-3 minutes then open it again.</li> <li>3. Cable is loosed from switch to power panel ,tighten them again .</li> <li>4. Open and close power switch constantly in short time cause machine is in protection circuit Close machine 2-3 minutes then open it again .</li> <li>5. Main circuit 24V relay of power panel is not close or has damaged .Check 24V power source and relay .If relay has damaged replace it with same model.</li> </ol>
Fan is working , Indicator is not lit and sound of HF arc-striking can not be heard ,wiping welding can not strike arc.	<ol style="list-style-type: none"> <li>1. Positive and negative electrodes of VH-07 insert component voltage should be about DC308v from power panel to MOS board .</li> <li>2. There is a green indicator in auxiliary power of MOS board ,if it is not on ,auxiliary power is out of work .Check fault spot and connect with seller .</li> <li>3. Check if connectors is poor contact .</li> <li>4. Check control circuit and find out reasons or connect with seller.</li> <li>5. Check if control cable of torch is broken.</li> </ol>
Abnormal indicator is not on,sound ofHF arc-striking can be heard ,but there is no welding output .	<ol style="list-style-type: none"> <li>1. Check if torch cable is broken .</li> <li>2. Check if grounding cable is broken or not connected to welding piece .</li> <li>3. Output terminal of positive electrode or torch electrify is loosed from inter-machine .</li> </ol>
Abnormal indicator is not lit,sound of HF arc-striking can not be heard ,wiping welding can strike arc .	<ol style="list-style-type: none"> <li>1. Primary cable of arc-striking transformer is not connected to power panel firmly ,tighten it again.</li> <li>2. Arc-striking tip is oxidized or too far ,give a good polish to it or change it is about 1 mm between arc-striking tip .</li> </ol>

	<p>3. Switch(sticking/argon-arc welding) is damaged ,replace it .</p> <p>4. Some of HF arc-striking circuit components is damage ,find out and replace it .</p>
<p>Abnormal indicator is lit but there is no welding output .</p>	<p>1. Maybe it is overheated protection ,please close machine first ,then open the machine again after abnormal indicator is out .</p> <p>2. Maybe it is overheated protection ,wait for 2-3 minutes (argon-arc welding does not has overheated protection function .)</p> <p>3. Maybe inverter circuit is in fault ,please pull up the supply power plug of main transformer which is on MOS board (VH-07 insert which is near the fan)then open the machine again.</p> <p>(1) If abnormal indicator is still lit ,close machine and pull up supply power plug of HF arc-striking power source (which is near the VN-07 insert of fan ),then open machine :</p> <p>a. If abnormal indicator is still lit ,some of fieldistor of MOS board is damaged ,find out and replace it with same model .</p> <p>b. If abnormal indicator is not lit , rise transformer of HF arc-striking circuit is damaged ,replace it .</p> <p>(2) If abnormal indicator is not lit ,</p> <p>a. Maybe transformer of middle board is damage ,measure inductance volume and Q volume of main transformer by inductance bridge(L=0.9-1.6mH Q&gt;35) .If volume is too low ,please replace it .</p> <p>b. Maybe secondary rectifier tube of transformer is damaged ,find out faults and replace rectifier tube with same model .</p> <p>4. Maybe feedback circuit is broken .</p>
<p>Output current is not stabilizing or out of potentiometer control and sometime is high ,sometime is low .</p>	<p>1. 1K potentiometer is damage ,replace it .</p> <p>2. All kinds of connectors are poor contact ,specially inserts etc. ,please check it .</p>
<p>Sticking spatter is too much and caustic electrode of is difficult .</p>	<p>Electrode is connected wrong ,exchange grounding cable and handle cable .</p>