

The logo for Kraus, featuring the brand name in a white serif font on a black background. The letter 'K' is stylized with a vertical line through it. The 'ä' has two dots above it. A registered trademark symbol (®) is located to the right of the 's'.

INSTALLATION MANUAL

# Aquila Single Lever Vessel Faucet

FVS-13900

## Thank you for your purchase

We would like to take this opportunity to thank you for choosing Kraus. We hope that you are completely satisfied with your purchase, and enjoy it for years to come. If you have any questions, or require technical assistance, please contact us at 800.775.0703 and one of our representatives will be happy to help.

For more information about Kraus products, please visit:

**[www.kraususa.com](http://www.kraususa.com)**

In order to activate your warranty and get faster access to customer support, please register your new Kraus product at:

**[www.kraususa.com/registration](http://www.kraususa.com/registration)**

*Sincerely,*

*Kraus USA Customer Service*

## Prior to Installation:

- Make sure you have all necessary parts by checking the diagram and parts list. If any part is missing or damaged, please contact Kraus Customer Service at 800-775-0703 for a replacement
- Turn off the hot and cold water supply at the angle stops and turn on the old faucet to release any built up pressure. Remove existing faucet. Clean sink or countertop to remove any debris, plumber's putty, or silicone
- Place bucket under angle stops. Turn on to flush any debris prior to installing new plumbing. Shut off angle stops
- Pre-drilled hole size requirement: 1-3/8" (min) – 1-1/2" (max)
- Max countertop thickness: 1-3/8"

**For technical assistance or replacement parts, please contact Kraus Customer Service and one of our representatives will be happy to help:**

Toll-Free: 800-775-0703 or [Customerservice@kraususa.com](mailto:Customerservice@kraususa.com)

## Tools you will need:

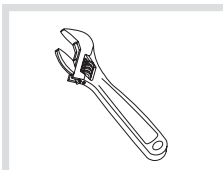

Adjustable Wrench

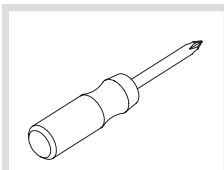

Phillips Screwdriver

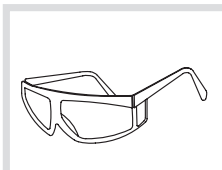

Safety Goggles

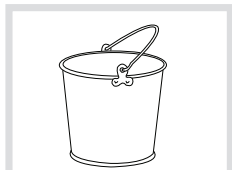

Bucket

## FVS-13900 Diagram and Parts List

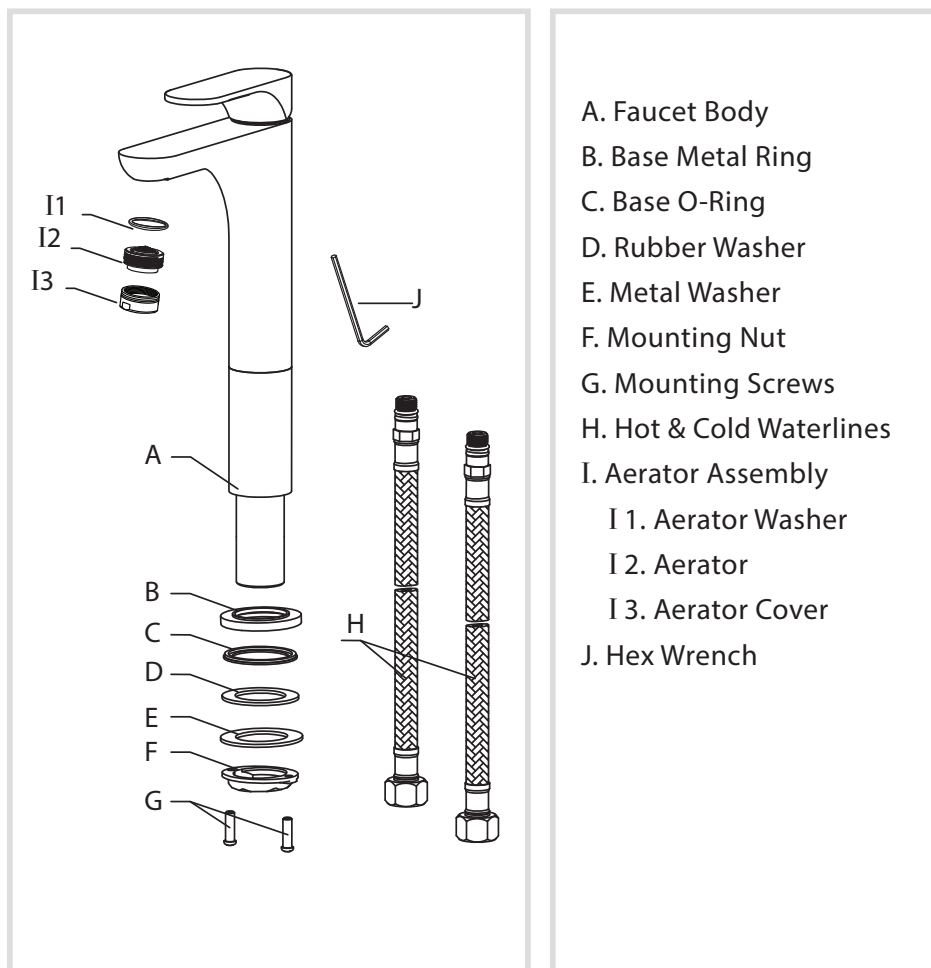

# Faucet Dimensions

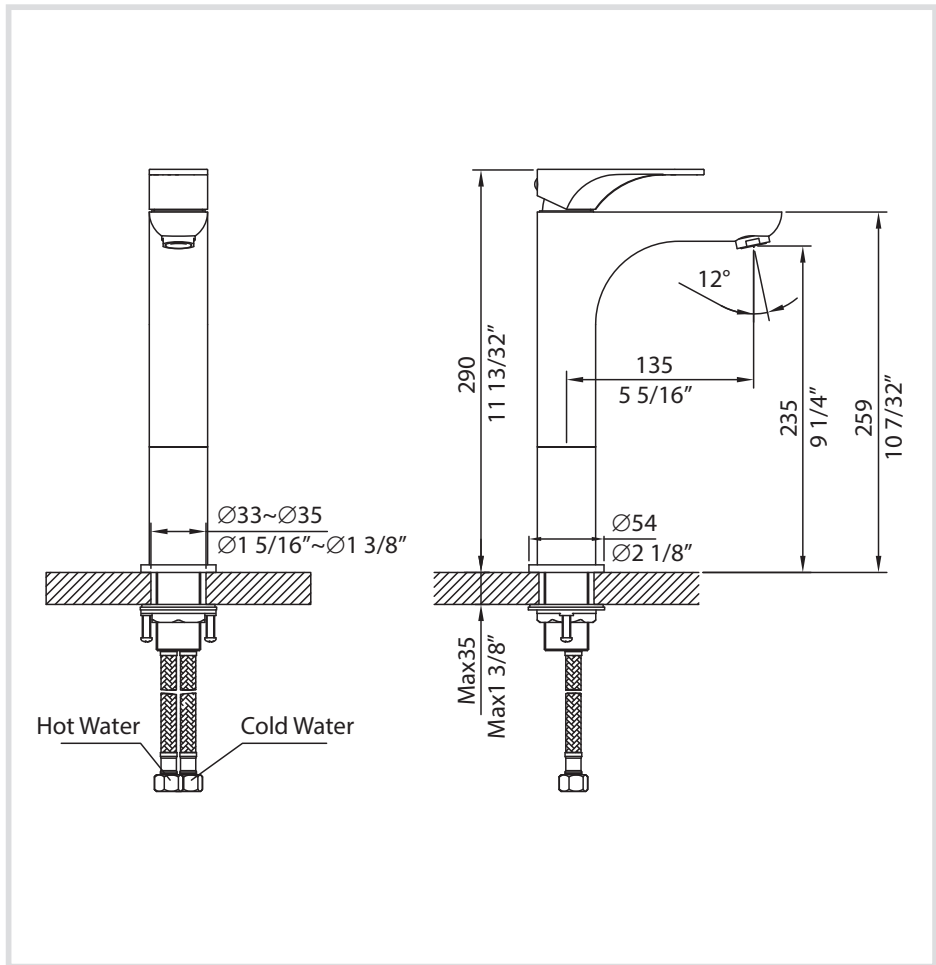

## Step 1: Install mounting hardware and waterlines

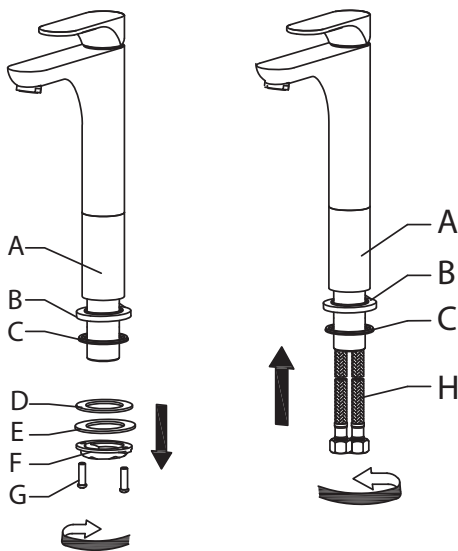

Remove mounting nut (F) with mounting screws (G) attached. Remove metal washer (E) and rubber washer (D) from threaded mounting pipe. Place faucet body (A) on a soft cloth, spout facing up. Secure the hot & cold waterlines (H) at the base of the faucet (HAND-TIGHTEN ONLY)

A. Hot Side: Left

B. Cold Side: Right

Place base O-ring (C) in groove of base metal ring (B)

## Step 2: Install faucet

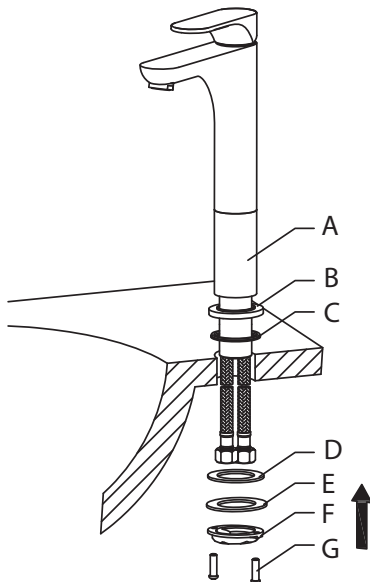

Install faucet body (A) through 1-3/8" hole in countertop, with hot & cold waterlines (H) and base O-ring (C) attached. Attach rubber washer (D), metal washer (E), and mounting nut (F) to threaded mounting pipe

### Step 3: Secure faucet

---

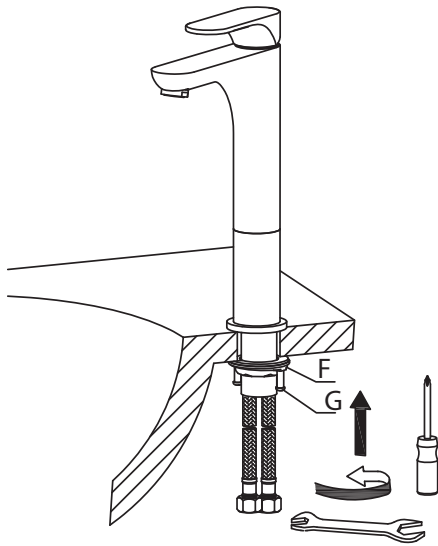

After adjusting direction of faucet body (A), tighten mounting nut (F) with adjustable wrench until snug. Secure mounting nut (F) by tightening mounting screws (G) with a Phillips head screwdriver

### Step 4: Connect waterlines to faucet and main valve

---

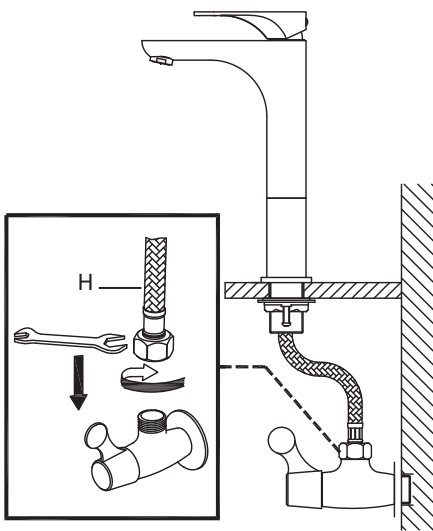

Thread hot & cold waterlines (H) onto angle stops and tighten with adjustable wrench until snug. Turn on angle stops and check for leaks

## Step 5: Flush faucet

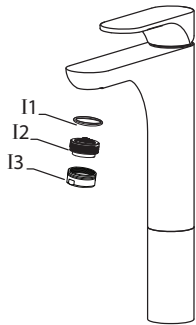

Remove aerator assembly (I). Loosen aerator cover (I 3) with adjustable wrench. Remove aerator (I 2) and aerator washer (I 1). Turn water on for 1 minute to remove any debris. Reassemble aerator assembly (I)

## Replacement Part List - FVS-13900

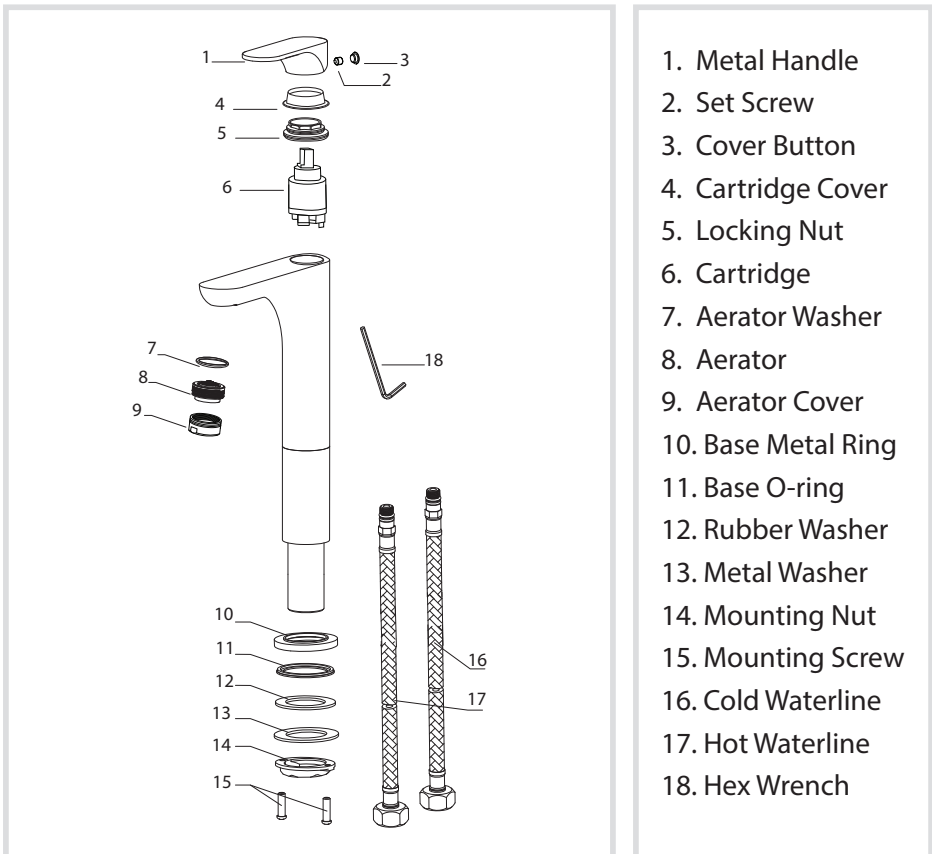



## Trouble - Shooting

If you have followed the instructions carefully and your faucet still does not work properly, take the following corrective steps:

PROBLEM	CAUSE	ACTION
Leakage under the handle	Locking nut (5) has come loose	Remove cover button (3). Loosen set screw (2) with hex wrench (18). Remove metal handle (1). Unscrew cartridge cover (4) (by hand only). Tighten locking nut (5) with adjustable wrench.
Aerator drips or has inconsistent water flow pattern	Aerator (8) may be dirty or not seated properly	Unscrew aerator cover (9) with adjustable wrench. Remove aerator (8) and clean out debris
Water will not shut off completely	Cartridge (6) may need to be adjusted or replaced	Remove cover button (3). Loosen set screw (2) with hex wrench (18). Remove metal handle (1). Unscrew cartridge cover (4) (by hand only). Unscrew locking nut (5) with adjustable wrench. Remove ceramic disc cartridge (6). Check for cracks

## Codes/Standards Applicable:



## HELP LINE

---

Our customer service hours are Monday – Friday, 9am – 8pm EST.  
Be sure to visit our website at [www.kraususa.com](http://www.kraususa.com)

### **If you are a homeowner please contact a Kraus Customer Service Representative at:**

Kraus USA, Inc.  
12 Harbor Park Drive  
Port Washington, NY 11050  
Toll-free 800-775-0703  
[Customerservice@kraususa.com](mailto:Customerservice@kraususa.com)

### **If you are a plumbing contractor or trade professional please contact a Kraus Pro Representative at:**

Kraus USA, Inc.  
12 Harbor Park Drive  
Port Washington, NY 11050  
516-801-8955  
[Proservice@kraususa.com](mailto:Proservice@kraususa.com)

### **If you are an Authorized Partner please contact a Partner Support Representative at:**

Kraus USA, Inc.  
12 Harbor Park Drive  
Port Washington, NY 11050  
516-801-8954  
[Partnersupport@kraususa.com](mailto:Partnersupport@kraususa.com)

### **In requesting warranty service, please be ready to provide:**

1. Proof of purchase.
2. A description of the problem.

# Care & Maintenance

\*To keep the product clean & shining, follow the steps below:

1. Rinse with clean water & dry with a soft cloth
2. Do not clean with soaps, acid, polish, abrasives, or harsh cleaners
3. Do not use cloth with a coarse surface
4. Unscrew the aerator and clean when necessary



\*This installation manual is subject to change without further notice.

**Download the Kraus Care & Maintenance Guide at:**

<http://www.kraususa.com/maintenance>

**Kräus®**

[www.kraususa.com](http://www.kraususa.com)

**REGISTER YOUR PRODUCT TODAY**

**Receive** Proof of Ownership  
**Access** Customer Care & Installation Help  
**Get** Exclusive Kraus Offers & Promotions



Scan to Register Online  
or visit <http://www.kraususa.com/registration>

**We're always looking for ways to improve.**

Please take a moment to share your experience.  
Visit <http://www.kraususa.com/review> to let us know what you think  
about your new Kraus product.

Contact Us to Learn More  
1.800.775.0703 / [www.kraususa.com](http://www.kraususa.com) / [customerservice@kraususa.com](mailto:customerservice@kraususa.com)  
Like & Follow KrausUSA

Download the Kraus Care & Maintenance Guide at:  
<http://www.kraususa.com/maintenance>



**Kräus<sup>®</sup>**

[www.kraususa.com](http://www.kraususa.com)