

# AUGUSTA

DESIGNER COLLECTION

H | S

## PVC SYSTEMS INCLUDE:

- Anti-vortex safety suction
- Color matched system trim
- HydroOzone ozone sanitation system
- Self draining pump and system
- Cable waste and overflow



# AUGUSTA

DESIGNER COLLECTION

# H | S

**As SHOWN:**

Acrylic Tub

**FEATURES SHOWN:**

- Tub Only

**ALSO AVAILABLE:**

- Soaking tub only
- Thermal Air

**Size:**

70.40.27

**WATER CAPACITY:**

110 Gallons

**WEIGHT:**

150 lbs. Tub Only

180 lbs. Thermal Air

**MODEL7248 DIMENSIONS:**

- (L)ength- 70"
- (W)idth- 40"
- (H)eight Finish- 27"



**ACRYLIC TUB**

- Acrylic models finished in 1/8" thick layer of deep lustrous acrylic
- Extra thick reinforced fiberglass
- Pre-wired pump on pump platform (standard pump location only)
- Integral E-Z level platform facilitates installation
- Non-skid bottom

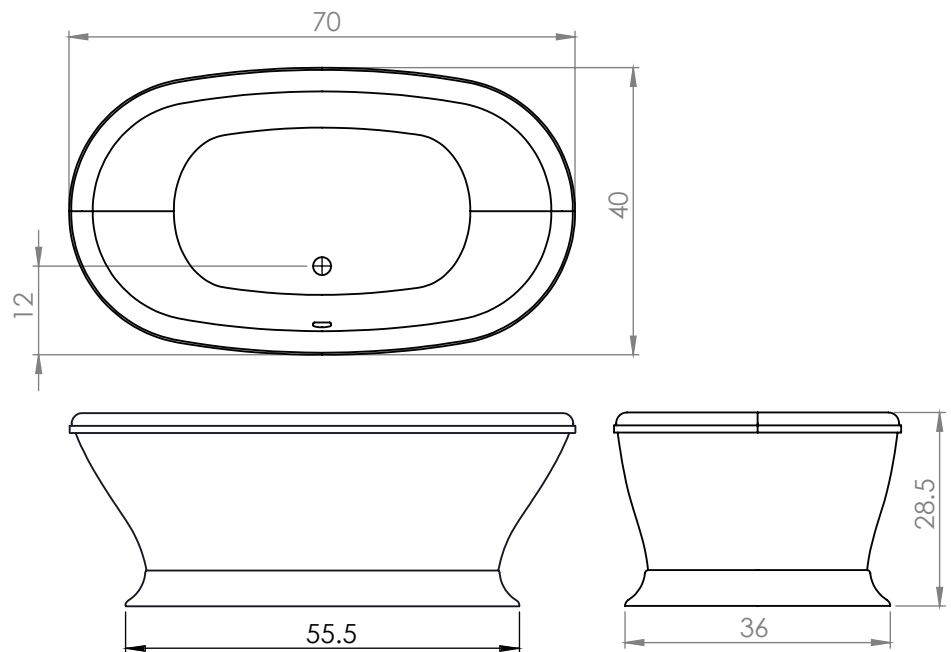

**CODES AND COMPLIANCES**

Massachusetts code File no: P1-0614-491



**HYDRO SYSTEMS**  
Family Owned And Operated Since 1978

29132 Avenue Paine, Valencia, CA, 91355  
661.775.0686 | hydrosystem.com

All specifications and options subject to change without notice please contact a Hydro Systems representative for more information. Certain options or altering the pump/blower location may cause the pump/blower to extend beyond the tub decking. For cutout dimensions wait for unit to arrive. All specifications subject to change without notice.