







Examine all packaging material for small parts that may have come loose during shipment. Periodic checks are recommended to insure that all components are in proper position, tight and free from damage. Keep this assembly instruction for future reference. Adult assembly is required. The product of Hillsdale Furniture, LLC is designed for residential use only. Customer Service Phone Number: 502-562-0000

HARDWARE LIST

- A (18) $\Phi 1/4"$ x 19 x 2mm Flat Washers
- B (18) $\Phi 1/4"$ x 13 x 1mm Spring Washers
- C (6) $\Phi 1/4"$ x 3/4" Bolts
- D (6) $\Phi 1/4"$ x 1-3/8" Bolts
- E (6) Nuts
- F (1) Wrench
- G (1) 4mm Allen Wrench
- H (2) Mounting Bars

PART	QTY	HARDWARE	PART	QTY	HARDWARE
A	18		B	18	
C	6		D	6	
E	6		F	1	
G	1		H	2	

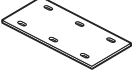
PARTS LIST

- I (1) Center Bridge
- J (2) Pier Tops
- K (2) Pier Bases

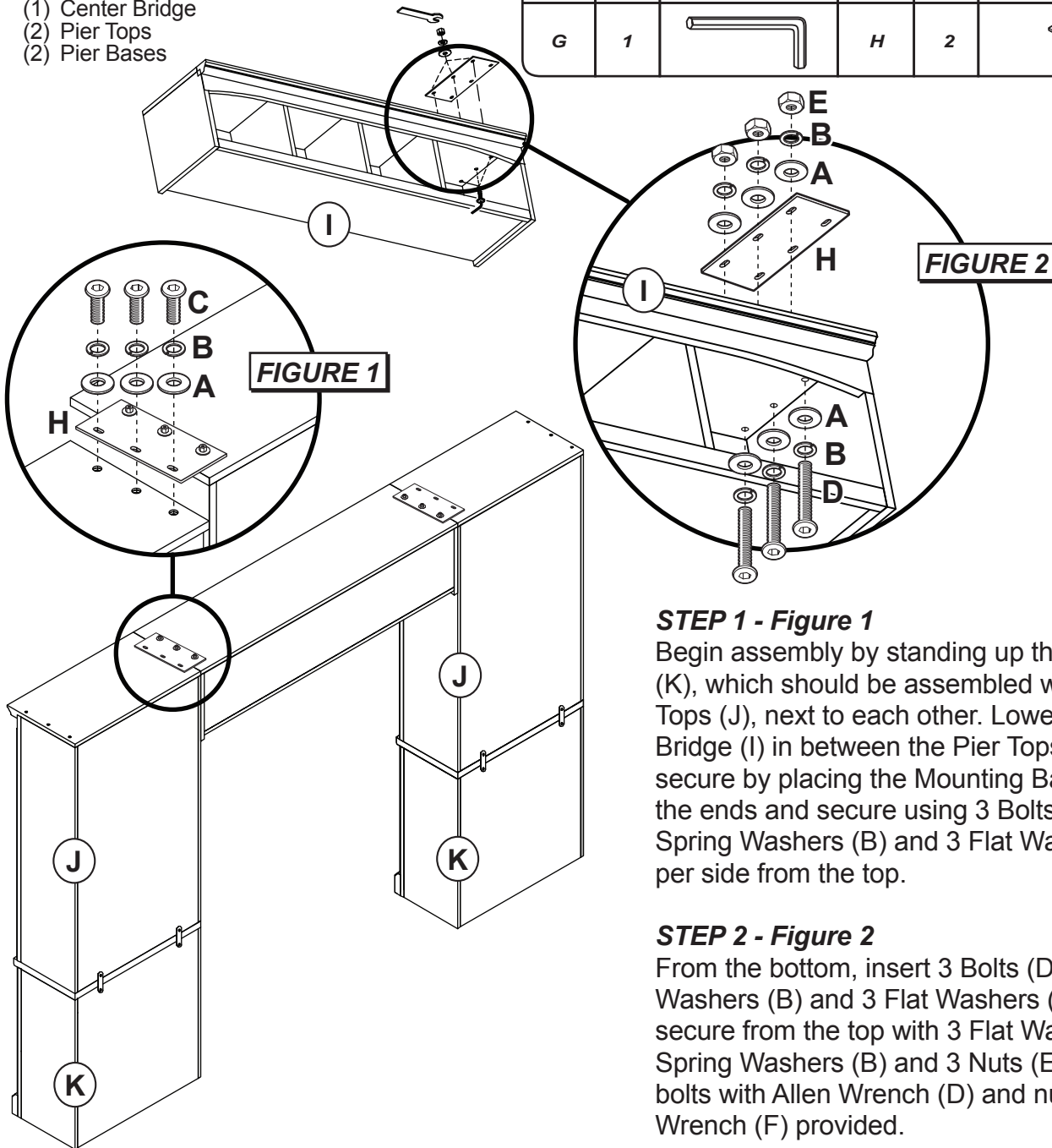
STEP 1 - Figure 1

Begin assembly by standing up the Pier Bases (K), which should be assembled with the Pier Tops (J), next to each other. Lower the Center Bridge (I) in between the Pier Tops (J) and secure by placing the Mounting Bars (H) on to the ends and secure using 3 Bolts (C), 3 Spring Washers (B) and 3 Flat Washers (A) per side from the top.

STEP 2 - Figure 2

From the bottom, insert 3 Bolts (D), 3 Spring Washers (B) and 3 Flat Washers (A) and secure from the top with 3 Flat Washers (A), 3 Spring Washers (B) and 3 Nuts (E). Tighten all bolts with Allen Wrench (G) and nuts with Wrench (F) provided.