

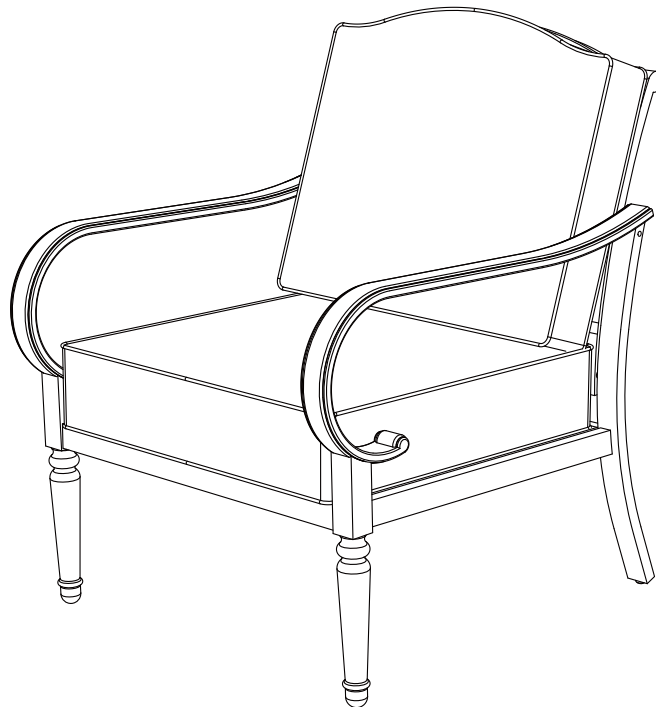

Item # XXX XXX
Model # 720.127.000

USE AND CARE GUIDE

LAUREL OAKS SINGLE SOFA



Questions, problems, missing parts? Before returning to the store,
call Hampton Bay Customer Service
8 a.m. - 7 p.m., EST, Monday - Friday,
9 a.m. - 6 p.m., EST, Saturday

1-855-HD-HAMPTON

HAMPTONBAY.COM

THANK YOU

We appreciate the trust and confidence you have placed in Hampton Bay through the purchase of this table. We strive to continually create quality products designed to enhance your home. Visit us online to see our full line of products available for your home improvement needs. Thank you for choosing Hampton Bay!

Table of Contents

Table of Contents	2	Hardware Included	3
Safety Information	2	Table Package Contents	4
Warranty	2	Assembly	5
What is covered	2	Care and Cleaning	6
What is not covered	2		
Pre-Assembly	3		
Planning Assembly	3		

Safety Information



CAUTION: Read all of the instructions in this manual before you begin assembly. Failure to do so may result in faulty assembly and potential injury!

Warranty

2 YEAR WARRANTY

WHAT IS COVERED

We warrant the product to be free of manufacturing defects to the original purchaser for two years.

WHAT IS NOT COVERED

It remains the customer's responsibility for freight and packaging charges to and from our service center. This warranty does not cover commercial use, hardware, acts of nature, freezing, or abusive use. In addition, purchased parts are not covered under this warranty.

We reserve the right to make substitutions with similar merchandise, if the model in question is no longer in production.

Contact Customer Care at 1-855-HD-HAMPTON or visit www.hamptonbay.com.

Pre-Assembly

PLANNING ASSEMBLY

Please read this entire instruction manual prior to assembly.

Identify all parts packed in the carton against the parts list. Remove all protective materials and place the parts on a non-abrasive surface to avoid scratching.



NOTE: More than one person may be required to assemble this product.

HARDWARE INCLUDED



NOTE: Hardware not shown to actual size.

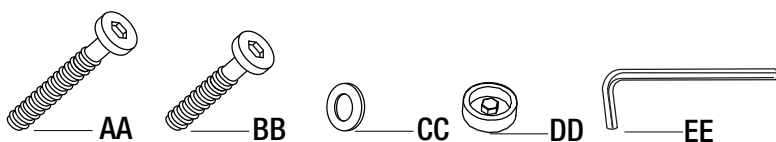

Part	Description	Quantity
AA	M6x55 Bolt	4
BB	M6x40 Bolt	4
CC	Washer	8
DD	Bolt cap	8
EE	Hex Wrench	1

Pre-Assembly

CHAIR PACKAGE CONTENTS



IMPORTANT: Do not fully tighten bolts/screws until all pieces are loosely assembled.

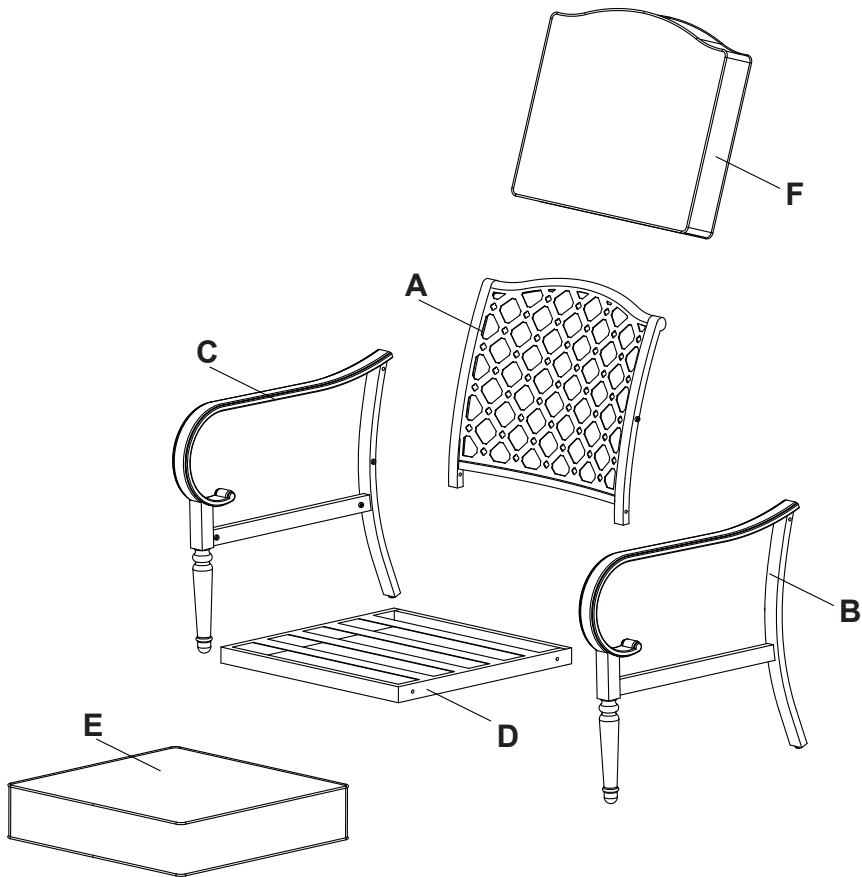

Part	Description	Quantity
A	Chair back	1
B	Left arm	1
C	Right arm	1
D	Chair seat	1
E	Seat cushion	1
F	Back cushion	1

Assembly

1 Attach the chair seat to the right arm

- Attach the chair seat (D) to the right arm (C) using M6 bolts (BB) and washers (CC).



NOTE: Please ensure all the bolts are assembled correctly and use the hex wrench (EE) to tighten. Do not fully tighten bolts/screws until all pieces are loosely assembled. Adding corresponding plastic caps after final assembly finished.

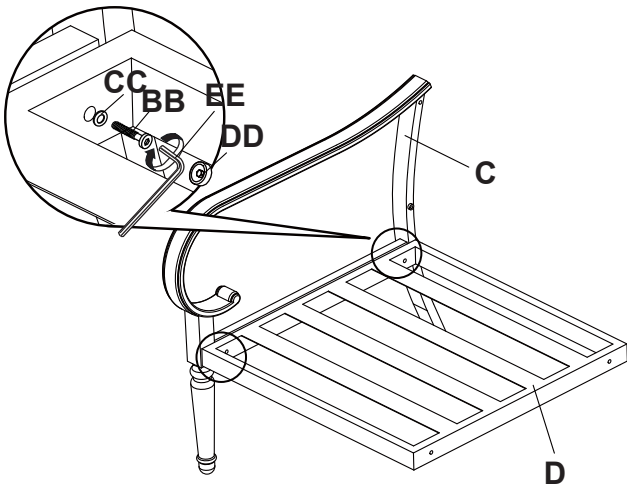

2 Attach the chair back to the right arm

- Attach the chair back (A) to the right arm (C) using M6 bolts (AA) and washers (CC).



NOTE: Please ensure all the bolts are assembled correctly and use the hex wrench (EE) to tighten. Do not fully tighten bolts/screws until all pieces are loosely assembled. Adding corresponding plastic caps after final assembly finished.

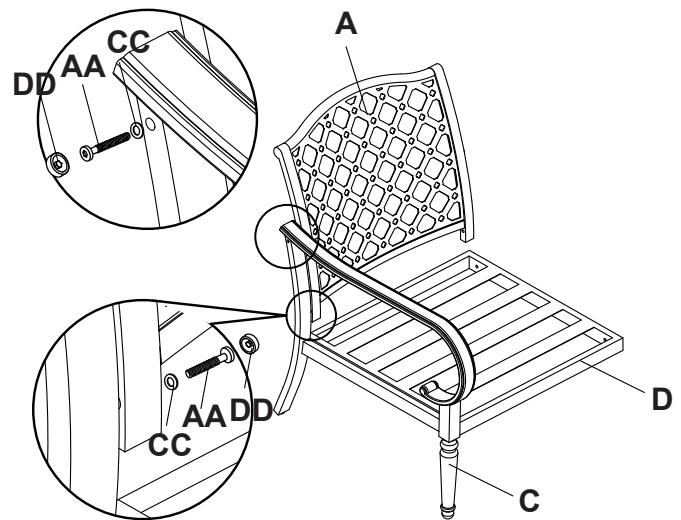

3 Attach the left arm to the chair seat and chair back

- Attach the left arm (B) to the chair seat (D) using M6 bolts (BB) and washers (CC), to the chair back (B) using M6 bolts (AA) and washers (CC).

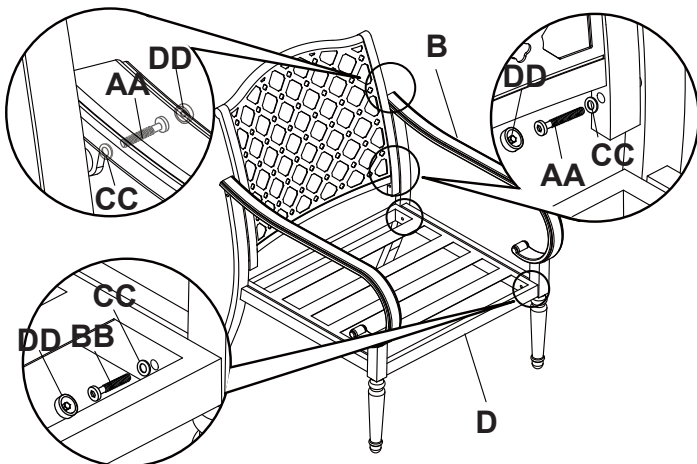

4 Add cushions

- Add seat cushion (E) and back cushion (F) on the chair.

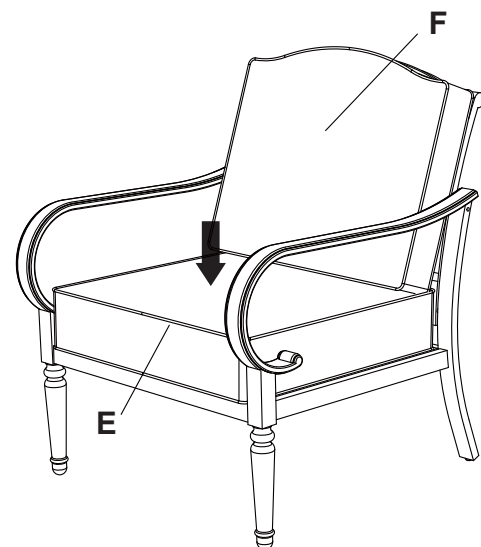

Care and Cleaning

- Do not allow water to build up in the frames. This will cause corrosion and possible freezing damage in cold climates.
- Use a mild soap and water for normal cleaning. Do not use janitorial or alcohol based cleaners. Some cleaners may be marked as natural, but some ingredients may cause discoloration or have an adverse reaction to your finish.
- Rinse with clean water and dry with a soft, absorbent cloth towel.
- Treat the frames with a liquid wax for maximum protection against UV rays and/or salty, damp air.



Questions, problems, missing parts? Before returning to the store,
call Hampton Bay Customer Service
8 a.m.-7 p.m., EST, Monday-Friday,
9 a.m.-6 p.m., EST, Saturday

1-855-HD-HAMPTON

HAMPTONBAY.COM

Retain this manual for future use.



Item # XXX XXX
Model # 720.127.000

USE AND CARE GUIDE

LAUREL OAKS LOVESEAT

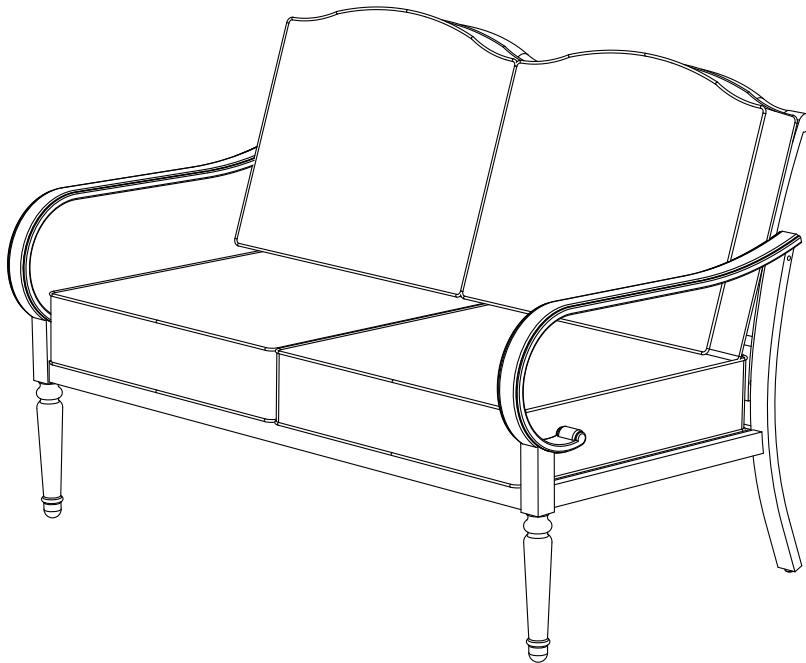

Questions, problems, missing parts? Before returning to the store,
call Hampton Bay Customer Service
8 a.m. - 7 p.m., EST, Monday - Friday,
9 a.m. - 6 p.m., EST, Saturday

1-855-HD-HAMPTON

HAMPTONBAY.COM

THANK YOU

We appreciate the trust and confidence you have placed in Hampton Bay through the purchase of this table. We strive to continually create quality products designed to enhance your home. Visit us online to see our full line of products available for your home improvement needs. Thank you for choosing Hampton Bay!

Table of Contents

Table of Contents	2	Hardware Included	3
Safety Information	2	Table Package Contents	4
Warranty	2	Assembly	5
What is covered	2	Care and Cleaning	6
What is not covered	2		
Pre-Assembly	3		
Planning Assembly	3		

Safety Information



CAUTION: Read all of the instructions in this manual before you begin assembly. Failure to do so may result in faulty assembly and potential injury!

Warranty

2 YEAR WARRANTY

WHAT IS COVERED

We warrant the product to be free of manufacturing defects to the original purchaser for two years.

WHAT IS NOT COVERED

It remains the customer's responsibility for freight and packaging charges to and from our service center. This warranty does not cover commercial use, hardware, acts of nature, freezing, or abusive use. In addition, purchased parts are not covered under this warranty.

We reserve the right to make substitutions with similar merchandise, if the model in question is no longer in production.

Contact Customer Care at 1-855-HD-HAMPTON or visit www.hamptonbay.com.

Pre-Assembly

PLANNING ASSEMBLY

Please read this entire instruction manual prior to assembly.

Identify all parts packed in the carton against the parts list. Remove all protective materials and place the parts on a non-abrasive surface to avoid scratching.



NOTE: More than one person may be required to assemble this product.

HARDWARE INCLUDED



NOTE: Hardware not shown to actual size.

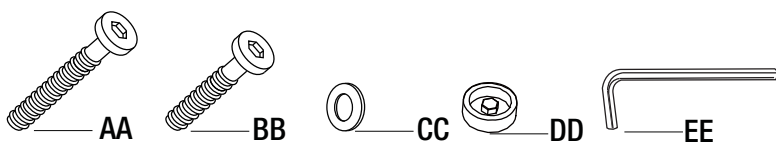

Part	Description	Quantity
AA	M6x55 Bolt	4
BB	M6x40 Bolt	4
CC	Washer	8
DD	Bolt cap	8
EE	Hex Wrench	1

Pre-Assembly

LOVESEAT PACKAGE CONTENTS



IMPORTANT: Do not fully tighten bolts/screws until all pieces are loosely assembled.

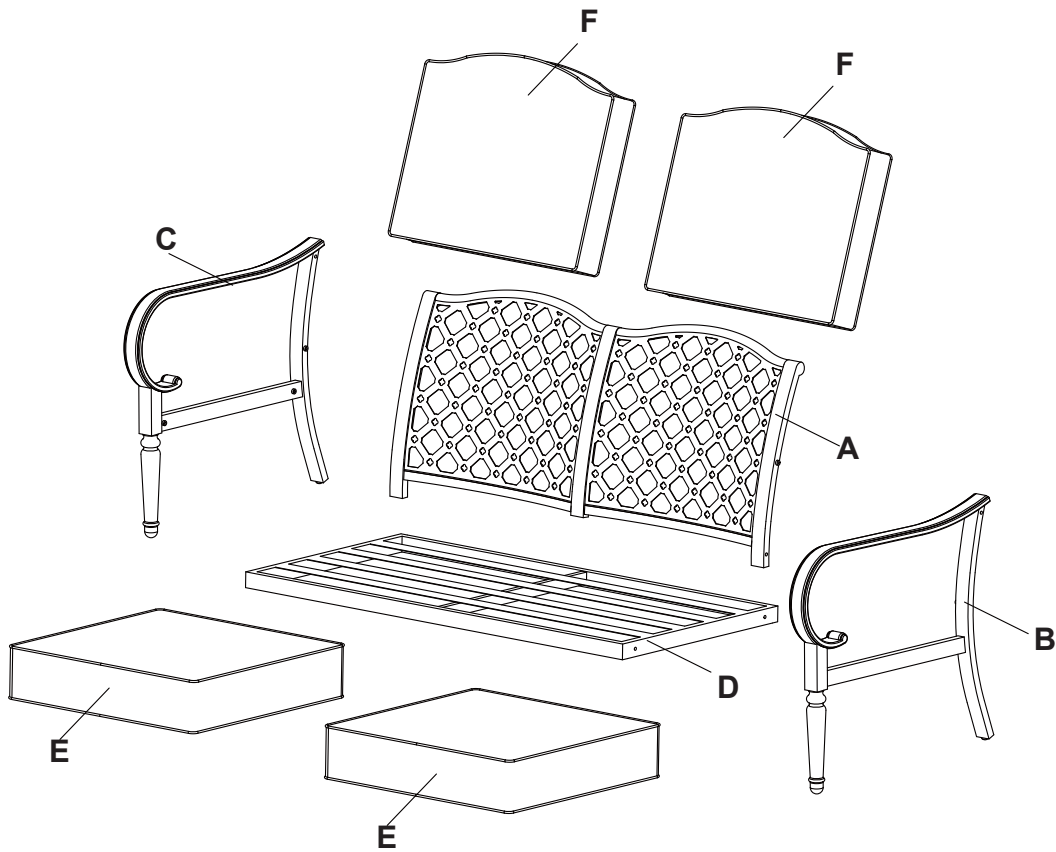

Part	Description	Quantity
A	Loveseat back	1
B	Left arm	1
C	Right arm	1
D	Loveseat seat	1
E	Seat cushion	2
F	Back cushion	2

Assembly

1 Attach the loveseat seat to the right arm

- Attach the loveseat seat (D) to the right arm (C) using M6 bolts (BB) and washers (CC).



NOTE: Please ensure all the bolts are assembled correctly and use the hex wrench (EE) to tighten. Do not fully tighten bolts/screws until all pieces are loosely assembled. Adding corresponding plastic caps after final assembly finished.

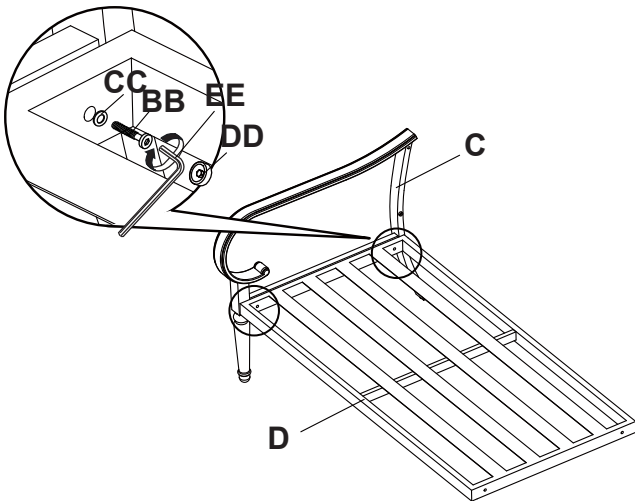

2 Attach the loveseat back to the right arm

- Attach the loveseat back (A) to the right arm (C) using M6 bolts (AA) and washers (CC).



NOTE: Please ensure all the bolts are assembled correctly and use the hex wrench (EE) to tighten. Do not fully tighten bolts/screws until all pieces are loosely assembled. Adding corresponding plastic caps after final assembly finished.

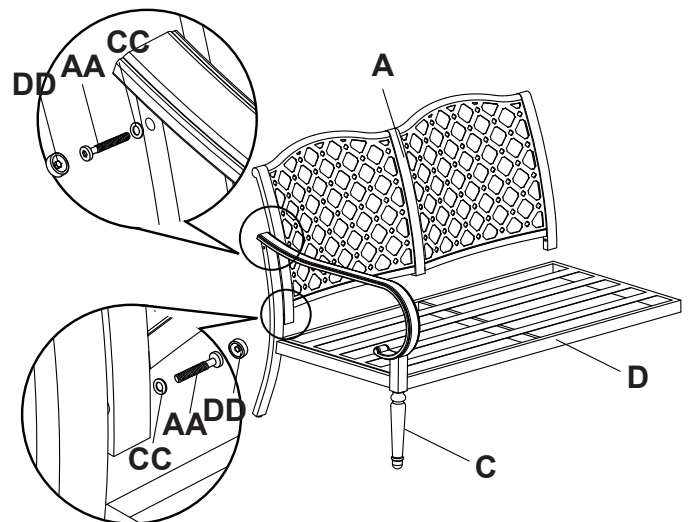

3 Attach the left arm to the loveseat seat and back

- Attach the left arm (B) to the loveseat seat (D) using M6 bolts (BB) and washers (CC), to the loveseat back (B) using M6 bolts (AA) and washers (CC).

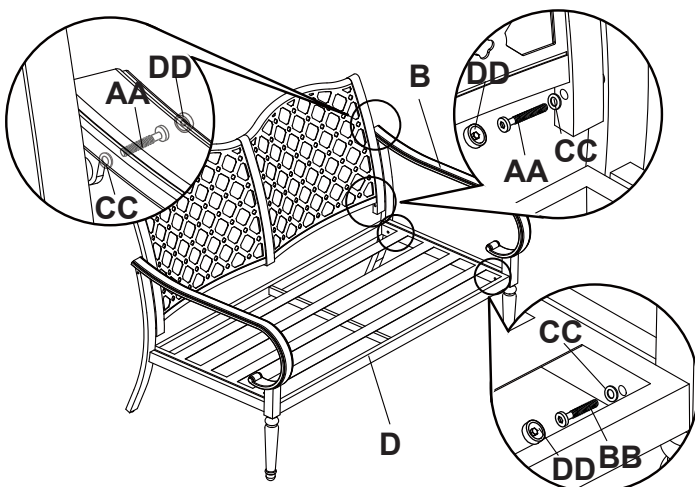

4 Add cushions

- Add seat cushion (E) and back cushion (F) on the chair.

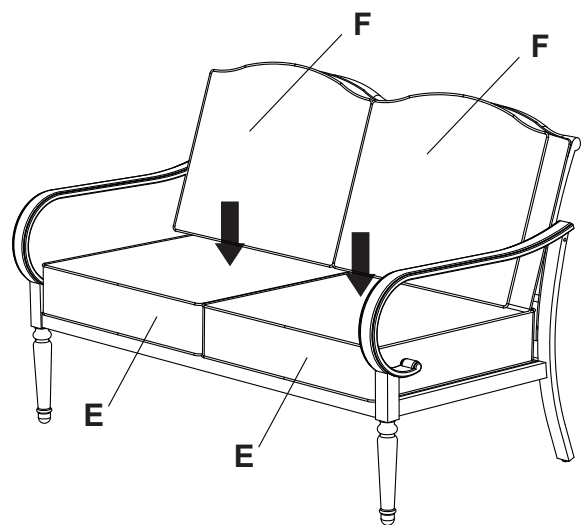

Care and Cleaning

- Do not allow water to build up in the frames. This will cause corrosion and possible freezing damage in cold climates.
- Use a mild soap and water for normal cleaning. Do not use janitorial or alcohol based cleaners. Some cleaners may be marked as natural, but some ingredients may cause discoloration or have an adverse reaction to your finish.
- Rinse with clean water and dry with a soft, absorbent cloth towel.
- Treat the frames with a liquid wax for maximum protection against UV rays and/or salty, damp air.



Questions, problems, missing parts? Before returning to the store,
call Hampton Bay Customer Service
8 a.m.-7 p.m., EST, Monday-Friday,
9 a.m.-6 p.m., EST, Saturday

1-855-HD-HAMPTON

HAMPTONBAY.COM

Retain this manual for future use.



Item # XXX XXX
Model # 720.127.000

USE AND CARE GUIDE

LAUREL OAKS COFFEE TABLE

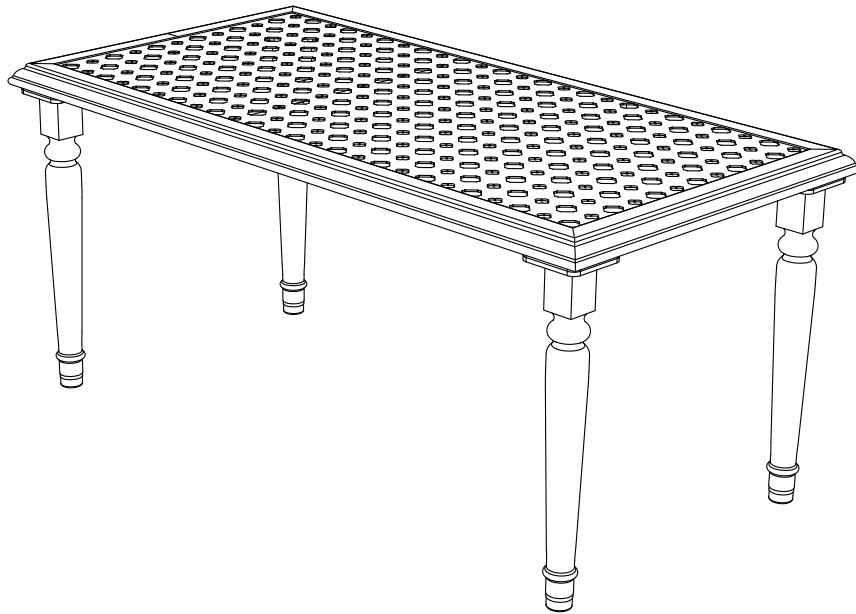

Questions, problems, missing parts? Before returning to the store,
call Hampton Bay Customer Service
8 a.m. - 7 p.m., EST, Monday - Friday,
9 a.m. - 6 p.m., EST, Saturday

1-855-HD-HAMPTON

HAMPTONBAY.COM

THANK YOU

We appreciate the trust and confidence you have placed in Hampton Bay through the purchase of this table. We strive to continually create quality products designed to enhance your home. Visit us online to see our full line of products available for your home improvement needs. Thank you for choosing Hampton Bay!

Table of Contents

Table of Contents	2	Hardware Included.	3
Safety Information	2	Table Package Contents.	4
Warranty	2	Assembly.	5
What is covered	2	Care and Cleaning	6
What is not covered.	2		
Pre-Assembly	3		
Planning Assembly.	3		

Safety Information



CAUTION: Read all of the instructions in this manual before you begin assembly. Failure to do so may result in faulty assembly and potential injury!

Warranty

2 YEAR WARRANTY

WHAT IS COVERED

We warrant the product to be free of manufacturing defects to the original purchaser for two years.

WHAT IS NOT COVERED

It remains the customer's responsibility for freight and packaging charges to and from our service center. This warranty does not cover commercial use, hardware, acts of nature, freezing, or abusive use. In addition, purchased parts are not covered under this warranty.

We reserve the right to make substitutions with similar merchandise, if the model in question is no longer in production.

Contact Customer Care at 1-855-HD-HAMPTON or visit www.hamptonbay.com.

Pre-Assembly

PLANNING ASSEMBLY

Please read this entire instruction manual prior to assembly.

Identify all parts packed in the carton against the parts list. Remove all protective materials and place the parts on a non-abrasive surface to avoid scratching.



NOTE: More than one person may be required to assemble this product.

HARDWARE INCLUDED



NOTE: Hardware not shown to actual size.



AA



BB



CC



DD



EE

Part	Description	Quantity
AA	M8x20 Bolt	12
BB	Washer	12
CC	Spring washer	12
DD	Bolt cap	12
EE	Hex Wrench	1

Pre-Assembly

TABLE PACKAGE CONTENTS



IMPORTANT: Do not fully tighten bolts/screws until all pieces are loosely assembled.

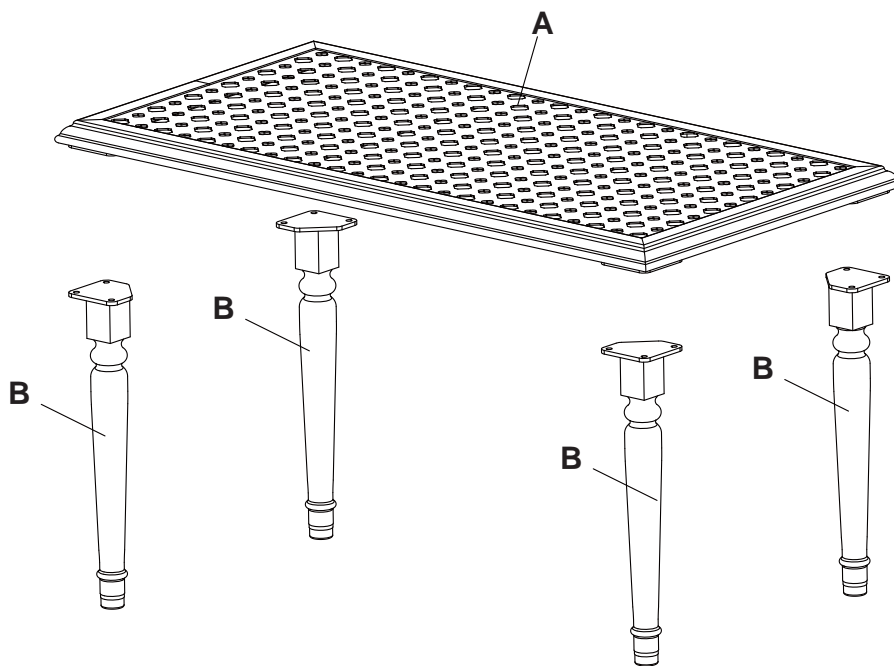

Part	Description	Quantity
A	Table top	1
B	Table legs	1

Assembly

1 Attach the table leg to the table top

- Put the table top on the soft ground. Attach the table leg (B) to the table top (A) using M8 bolts (AA), washers (BB) and spring washers (CC).



NOTE: Please ensure all the bolts are assembled correctly and use the hex wrench (EE) to tighten. Do not fully tighten bolts/screws until all pieces are loosely assembled. Adding corresponding plastic caps after final assembly finished.

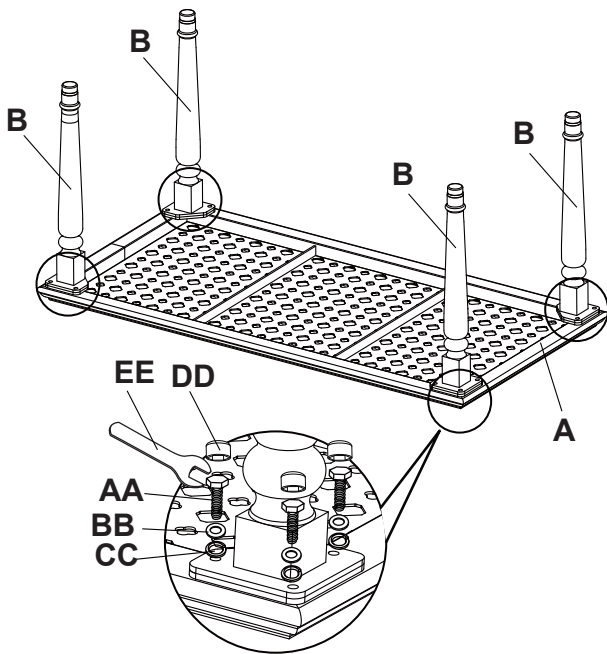

2 Turn the table over

- Turn the table over and set on the ground.

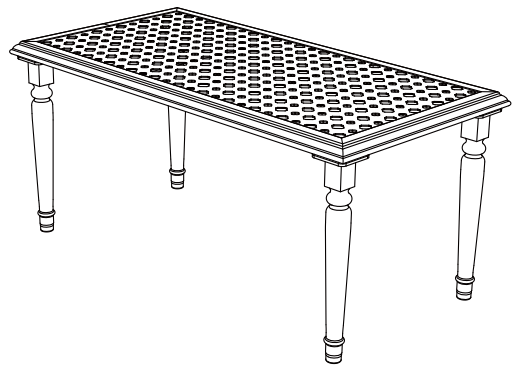

Care and Cleaning

- Do not allow water to build up in the frames. This will cause corrosion and possible freezing damage in cold climates.
- Use a mild soap and water for normal cleaning. Do not use janitorial or alcohol based cleaners. Some cleaners may be marked as natural, but some ingredients may cause discoloration or have an adverse reaction to your finish.
- Rinse with clean water and dry with a soft, absorbent cloth towel.
- Treat the frames with a liquid wax for maximum protection against UV rays and/or salty, damp air.



Questions, problems, missing parts? Before returning to the store,
call Hampton Bay Customer Service
8 a.m.-7 p.m., EST, Monday-Friday,
9 a.m.-6 p.m., EST, Saturday

1-855-HD-HAMPTON

HAMPTONBAY.COM

Retain this manual for future use.