

Grill Table Kit

ASSEMBLY INSTRUCTIONS

YellaWood
Pressure Treated Pine

OVERVIEW

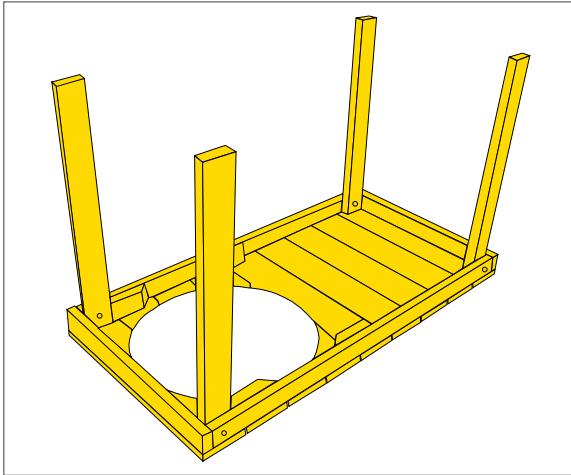

1

Place the Table Top Assembly face down on a flat surface.

2

Place four legs in corners as needed for pre-drilled hole to align (see Note 1). Using socket wrench or an adjustable wrench, secure in place with bolts, washers and nuts.

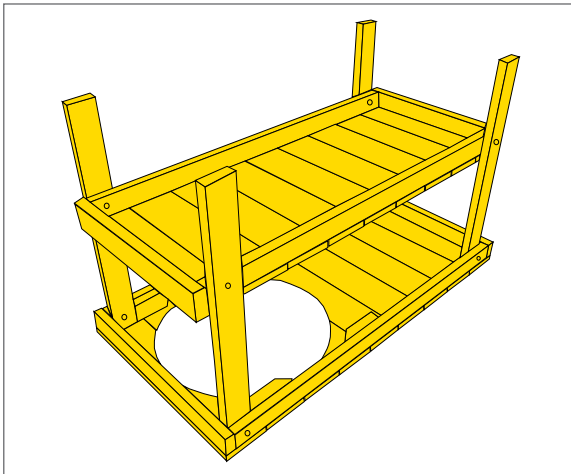

3

Position the Table Shelf Assembly at the appropriate height for your grill (see Note 2).

4

Secure with bolts, washers, and nuts. Tighten nuts with a socket wrench or an adjustable wrench.

PACKAGE INCLUDES

1x	Table Top Assembly
1x	Table Shelf Assembly
4x	Legs
8x	Carriage Bolts
8x	Washers
8x	Nuts

TOOLS NEEDED

Socket Wrench **OR** an Adjustable Wrench

NOTES

1. Each leg will match with a pre-drilled hole. You may have to rotate the legs and try them in different locations to get the pre-drilled holes to align.
2. There are 3 locations for shelf height. Choose the one that best fits your grill. A 22.5" diameter grill is the largest grill that will fit in this table.
3. A paving stone may be required to be placed under the grill. Check manufacturer's instructions for your specific grill.
4. Stain, seal or paint your grill table immediately for the best protection from the elements.
5. These instructions are for the grill table only. Grill sold separately.

Grill Table Kit

IMPORTANT INFORMATION

YellaWood®
Pressure Treated Pine

- Consult the end tag to determine which preservative or preservative system was used in the treatment of that particular product. YellaWood® brand products may be used in direct contact with aluminum building products when limited to code-compliant construction applications that provide proper water drainage and do not allow the wood to be exposed to standing water or water immersion.
- Use fasteners and other hardware that are in compliance with building codes for the intended use.
- Do not burn preserved wood.
- Wear a dust mask and goggles when cutting or sanding wood.
- Wear gloves when working with wood.
- Some preservative may migrate from the treated wood into soil/water or may dislodge from the treated wood surface upon contact with skin.
- Wash exposed skin areas thoroughly.
- All sawdust and construction debris should be cleaned up and disposed of after construction.
- Wash work clothes separately from other household clothing before reuse.
- Preserved wood should not be used where it may come into direct or indirect contact with drinking water, except for uses involving incidental contact such as fresh water docks and bridges.
- Do not use preserved wood under circumstances when the preservative may become a component of food, animal feed or beehives.
- Do not use preserved wood as mulch.
- Only preserved wood that is visibly clean and free of surface residue should be used. If the wood is to be used in an interior application and becomes wet during construction, it should be allowed to dry before being covered or enclosed.
- Mold growth can and does occur on the surface of many products, including untreated and treated wood, during prolonged surface exposure to excessive moisture conditions. To remove mold from the treated wood surface, wood should be allowed to dry. Typically, mild soap and water can be used to remove remaining surface mold. For more information visit www.epa.gov.
- Projects should be designed and installed in accordance with federal, state and local building codes and ordinances governing construction in your area, and in accordance with the National Design Specifications (NDS) and the Wood Handbook.

YellaWood® brand pressure treated products are treated with preservatives (the “Preservatives”) and preservative methods, and technologies of unrelated third parties. For details regarding the Preservatives, methods, and technologies used by Great Southern Wood Preserving, Incorporated, see yellawood.com/preservative or write us at P.O. Box 610, Abbeville, AL 36310. Ask dealer for warranty details. For warranty or for important handling and other information concerning our products including the appropriate Safety Data Sheet (SDS), please visit us at yellawood.com/warranties or write us at P.O. Box 610, Abbeville, AL 36310. YellaWood® and the yellow tag are federally registered trademarks of Great Southern Wood Preserving, Incorporated.

Great Southern Wood Preserving, Incorporated makes no warranties expressed or implied as to the fitness for a particular purpose of this plan.

DISPOSAL RECOMMENDATIONS

Preserved wood may be disposed of in landfills or burned in commercial or industrial incinerators or boilers in accordance with federal, state and local regulations.

Revised June 2018