

Assembly Instructions

D-DN1496SAL



IMPORTANT:

Please read instructions thoroughly before assembly, get yourself familiar with the parts list and assembly illustrations to ensure the safe and proper assembly.

Please keep the instructions for future reference.

WARNING:

Repeated assembly can weaken the locking ability of the washers. Please periodically check all bolted connections on your bistro to ensure they are tight and secure.

DO NOT over tighten any screws or nuts.

DO NOT operate if any part is damaged or broken.

NOT FOR USE BY CHILDREN.

Table assembly instruction

Part#	Description	QTY
A	Tabletop	1
B	Shelf	1
C	Leg	4
AA	Bolt M6x35	8
BB	M6 Spring washer	8
CC	M6 Nut	8
DD	M6 Wrench	2
	Foot pad (Preassembled on legs)	4

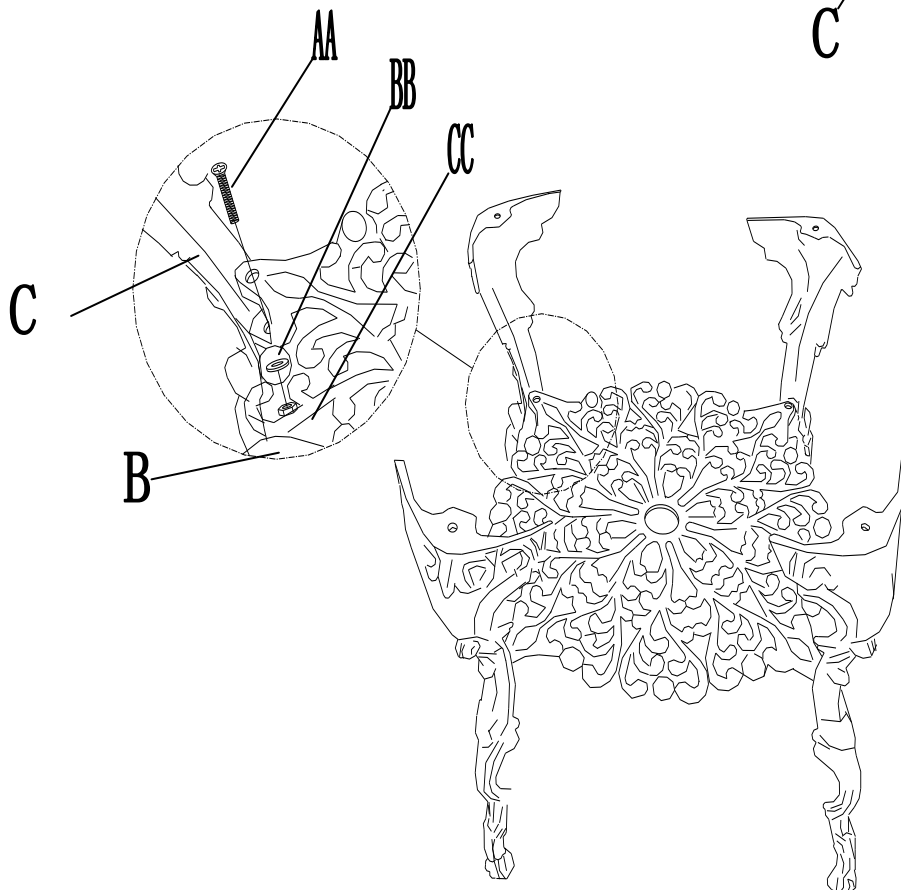
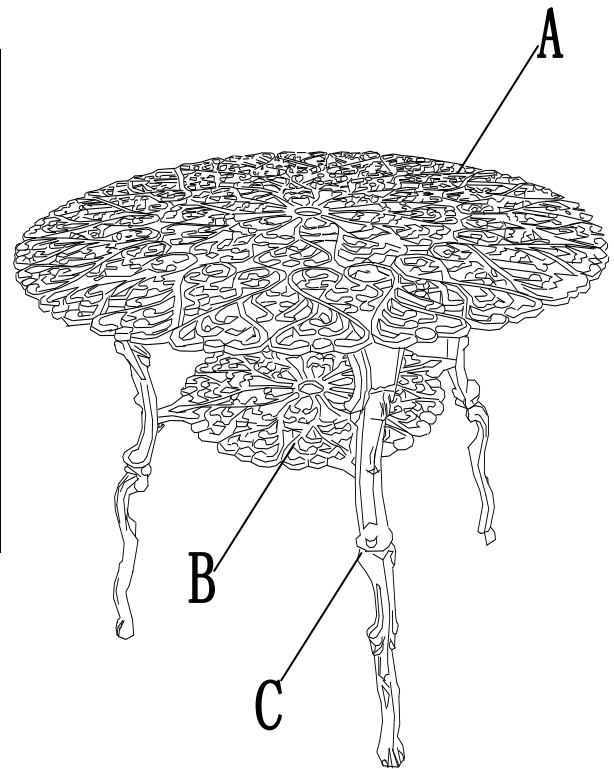

Step 1: Attach leg(C) to shelf (B) with bolt (AA) and spring washer(BB), lock with nut (CC) by using wrench(DD) and Philips-screwdriver, do not tighten fully.

Step 2: Attach leg(C) to tabletop (A) with bolt (AA) and spring washer (BB), lock with nut (CC) by using wrench (DD) and Philips-screwdriver. Adjust the table to be stable, tighten all the bolts and you may have the complete table.

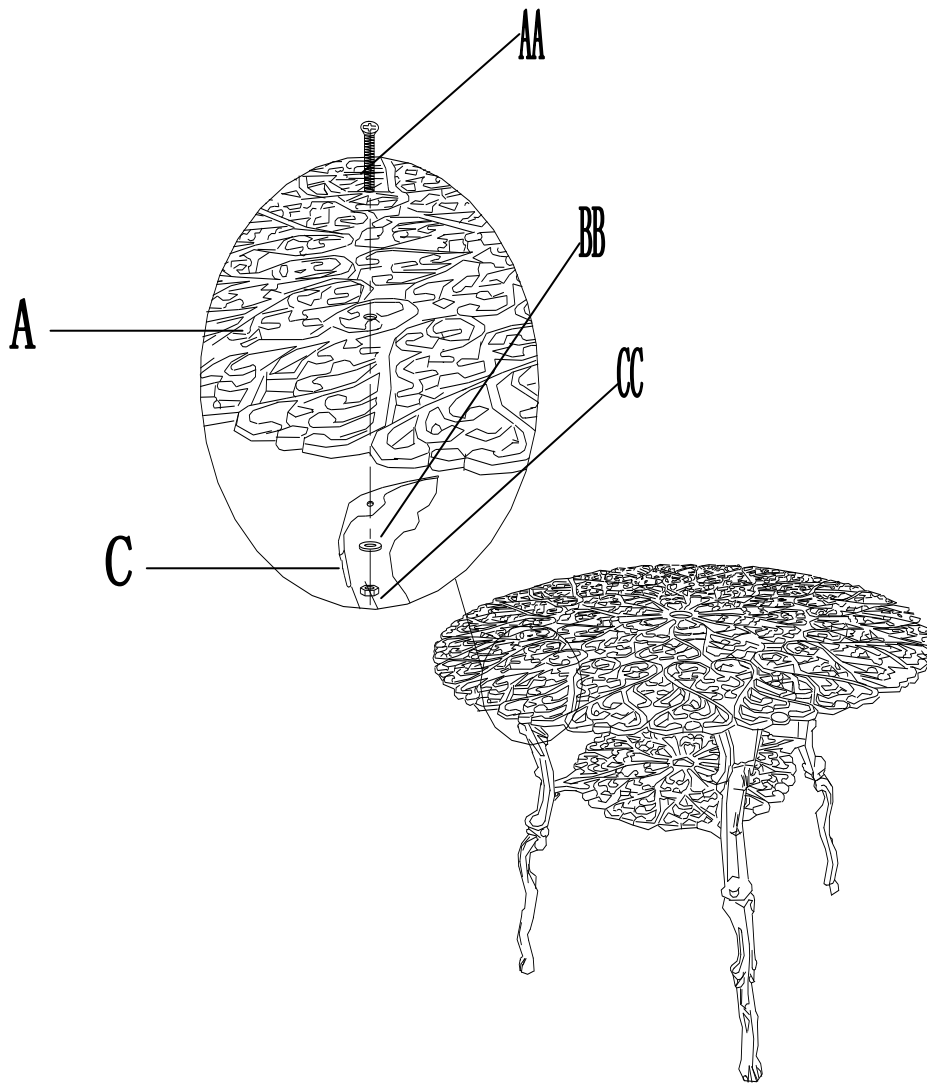

Chair assembly instruction

Part #	Description	QTY
A	Back	1
B	Armrest1	1
C	Armrest2	1
D	Seat	1
E1	Front side Leg	2
E2	Backside Leg	2
F	Decorative part	1
G	Support bar	2
AA	Bolt M6x35	20
BB	Spring washer M6	20
CC	Nut M6	20
DD	Wrench M6	2
	Foot Pad (Preassembled on legs)	4

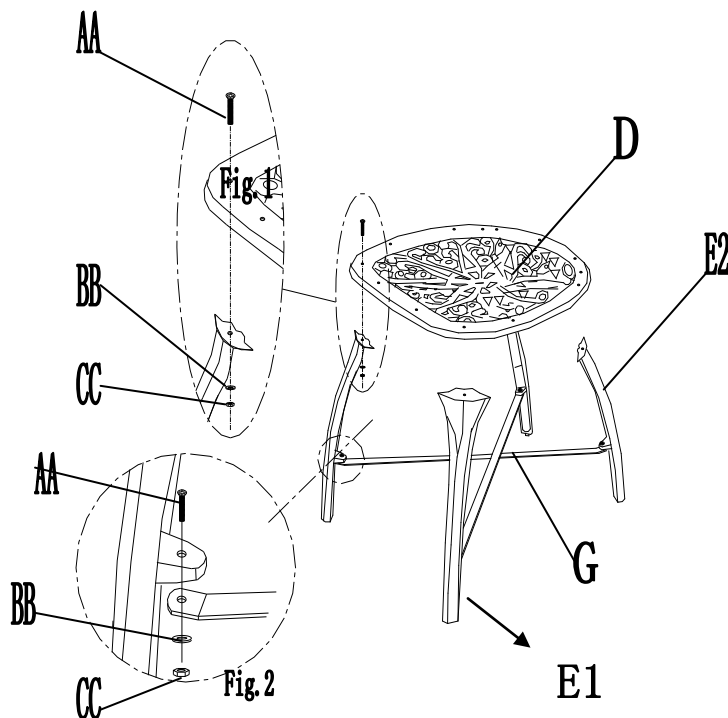
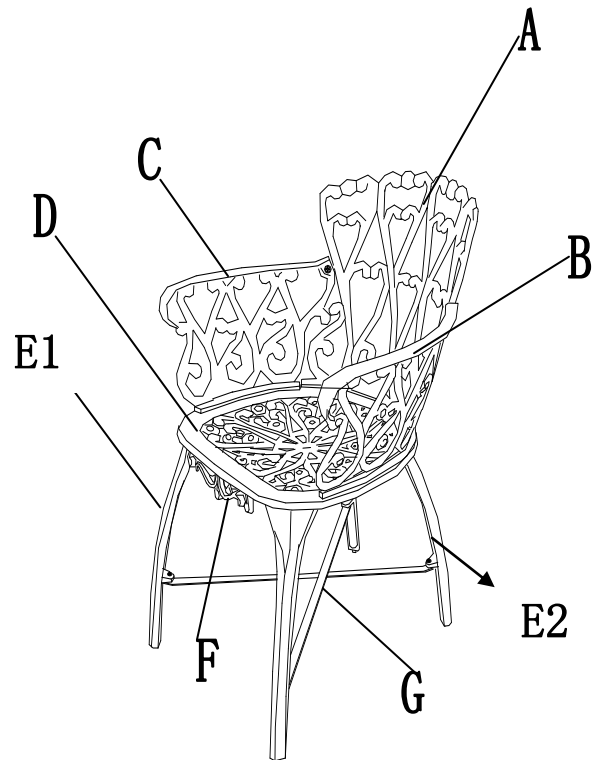

Step 1: Attach leg (E1/E2) to seat (D) with (AA) and spring washer (BB), lock by nut M6 (CC) by using wrench (DD) and Philips-screwdriver as Fig. 1 shown, don't tighten fully. Attached the two support bar (G) to legs (E) with bolt (AA), spring washer (BB).And nut (CC) by using wrench (DD) as Fig.2 shown.

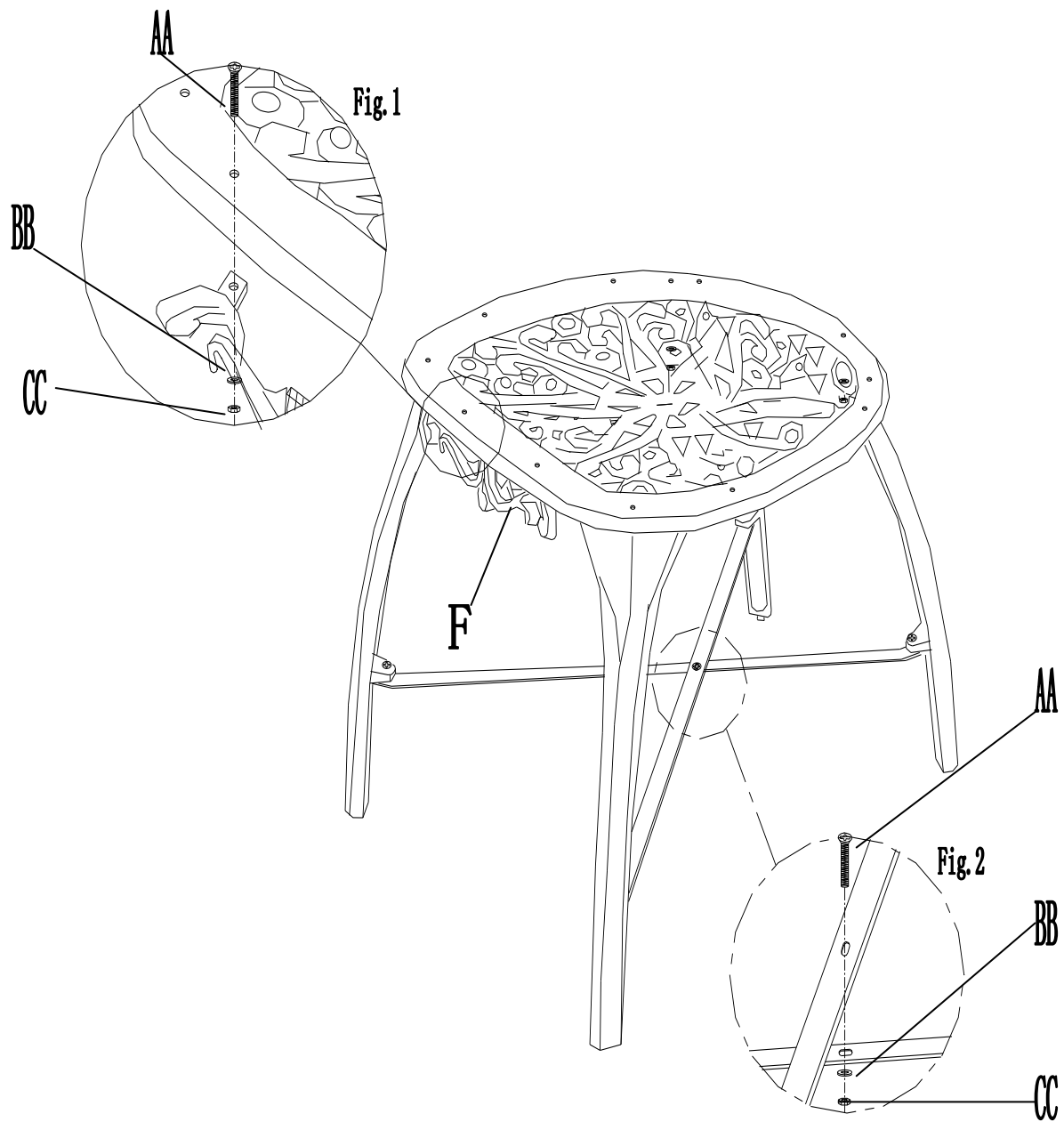

Step 2: Attach decorative part (F) to seat (D) with bolt (AA) and spring washer (BB), secure by nut (CC) by using wrench (DD) and Philips-screwdriver as showed on picture. Fix the two support bar (G) by bolt (AA) and nut (CC). Adjust the chair base to be stable, and tighten all bolts.

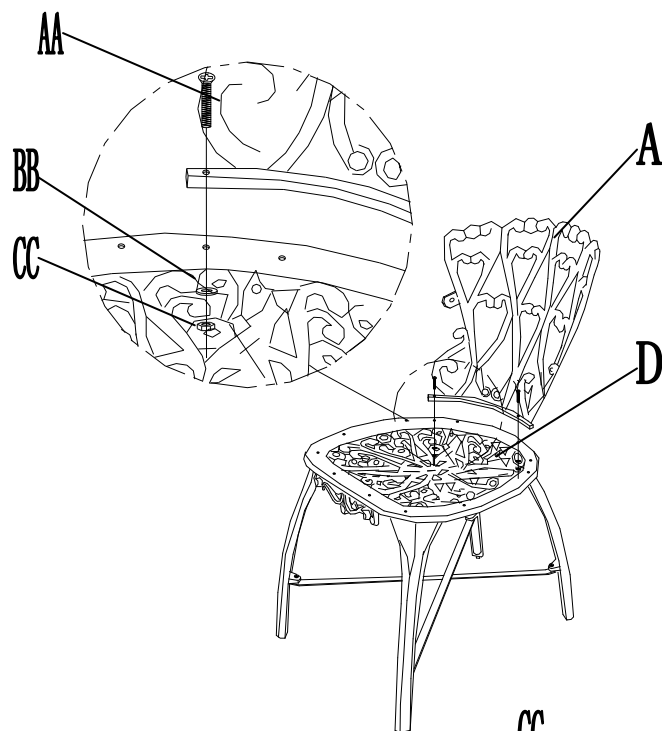

Step3: Attach back (A) to seat (D) with bolt (AA) and spring washer (BB), then lock And tighten with nut (CC) using wrench (DD) and Philips-screwdriver.

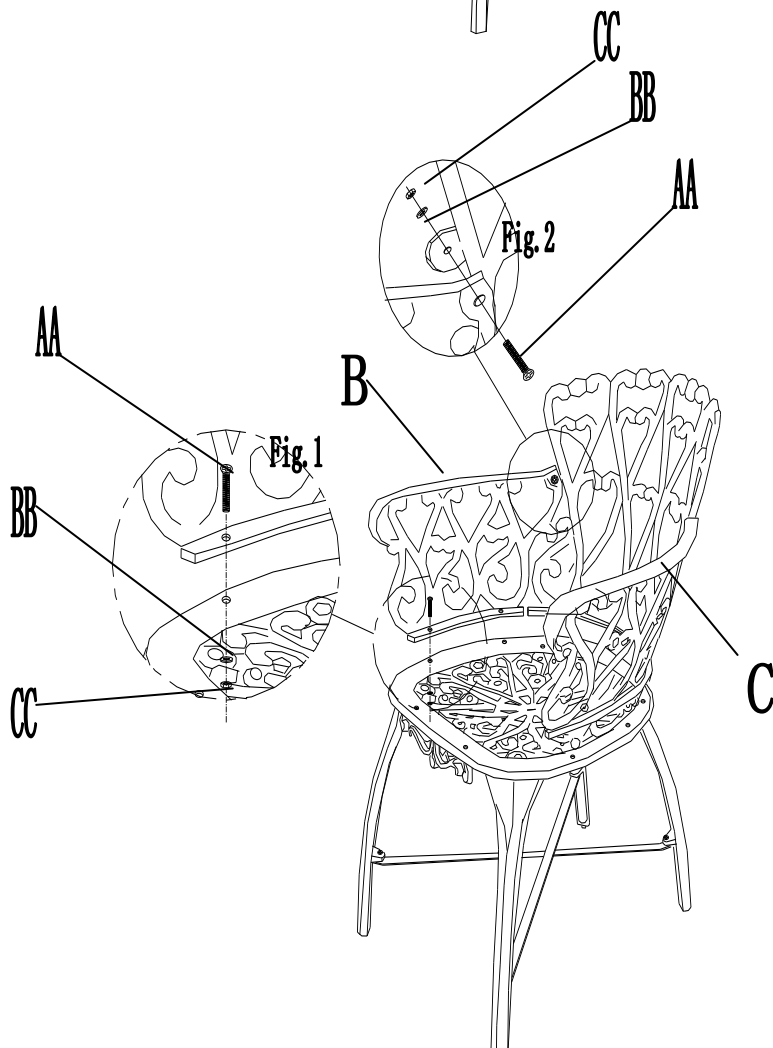

Step 4: Attach bottom of armrest (B), (C) to seat (D) with bolt (AA) spring washer (BB), lock and tighten by nut (CC) using wrench (DD) and Philips-screwdriver. Attach side of armrest (B), (C) to back (A) with bolt (AA) and spring washer (BB), secure and tighten by (CC) using wench (DD) and Philips-screwdriver.

Loveseat Assembly Instruction

Part #	Description	QTY
A	Back	1
B	Armrest1	1
C	Armrest2	1
D	Seat	1
E1	Front Leg	2
E2	Back Leg	2
F	Decorative part	1
G	Support bar	2
AA	Bolt M6x35	21
BB	Spring washer M6	21
CC	Nut M6	21
DD	Wrench M6	2
	Foot Pad (Preassembled on legs)	4

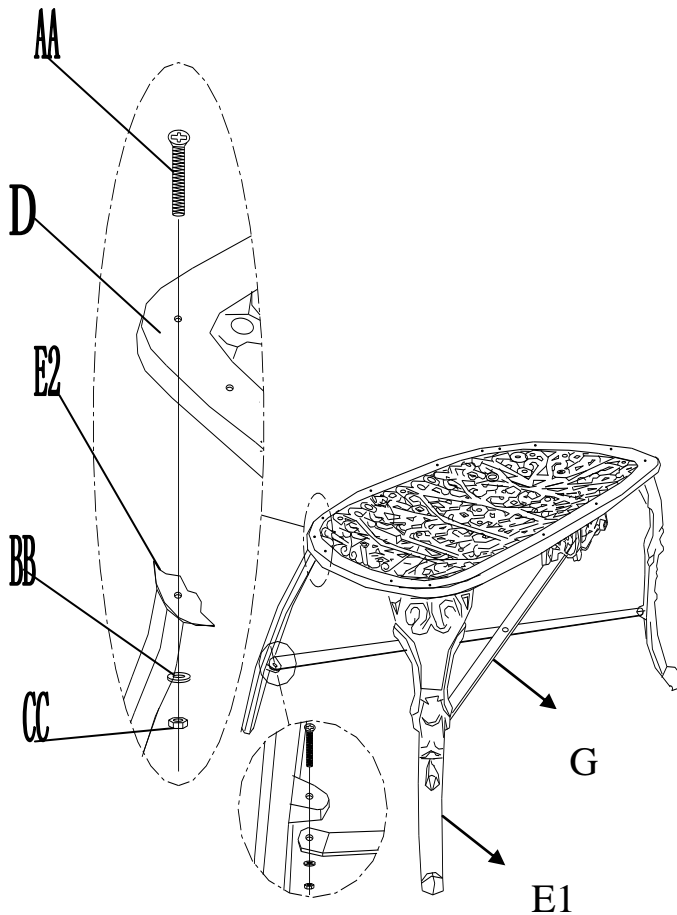
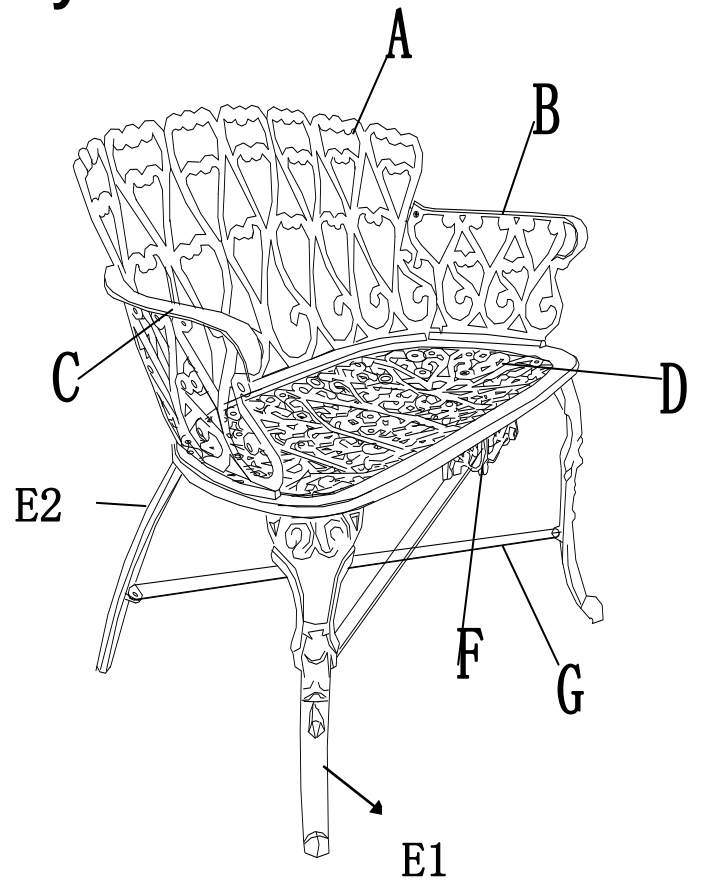

Step 1: Attach leg (E1/E2) to seat (D) with (AA) and spring washer (BB), lock by nut (CC) by using wrench (DD) and Philips-screwdriver as Fig. 1 shown, don't tighten fully.

Attached the two support bar (G) to legs (E) with bolt (AA), spring washer (BB) And nut (CC) by using wrench (DD).

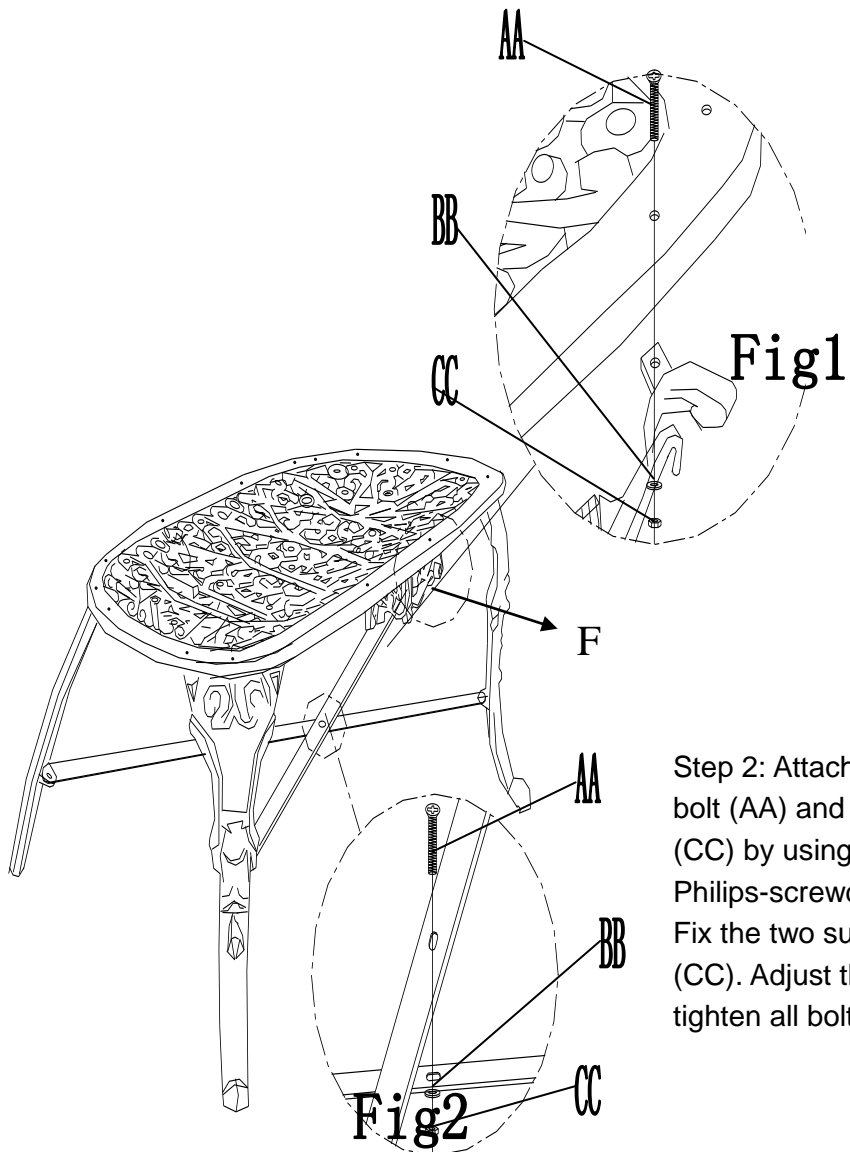

Step 2: Attach decorative part (F) to seat (D) with bolt (AA) and spring washer (BB), secure by nut (CC) by using wrench (DD) and Philips-screwdriver as showed on picture. Fix the two support bar (G) by bolt (AA) and nut (CC). Adjust the chair base to be stable, and tighten all bolts.

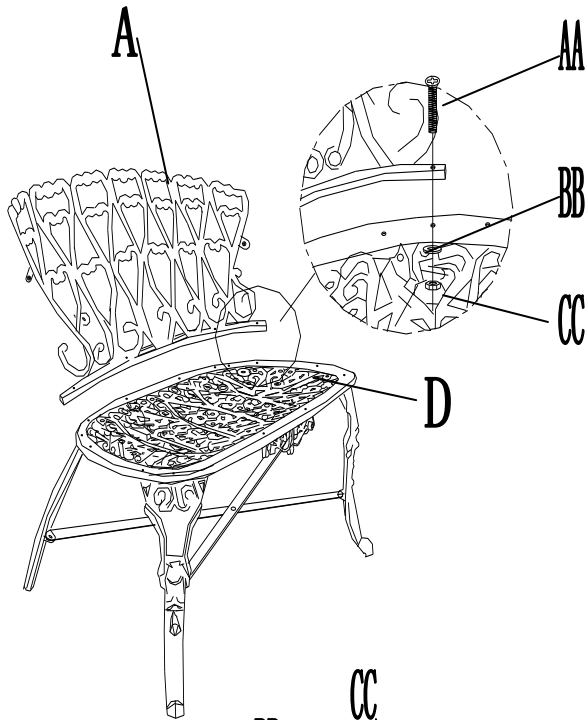

Step3: Attach back (A) to seat (D) with bolt (AA) and spring washer (BB), then lock And tighten with nut (CC) using wrench (DD) and Philips-screwdriver.

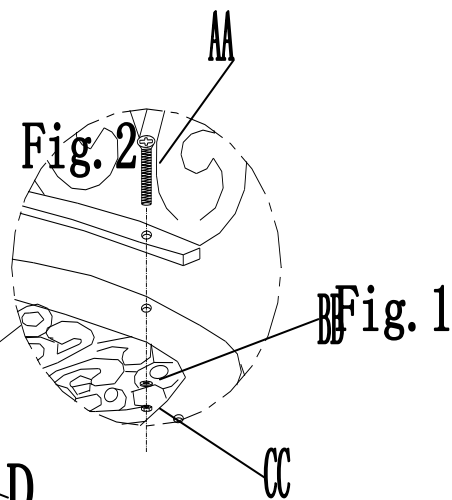
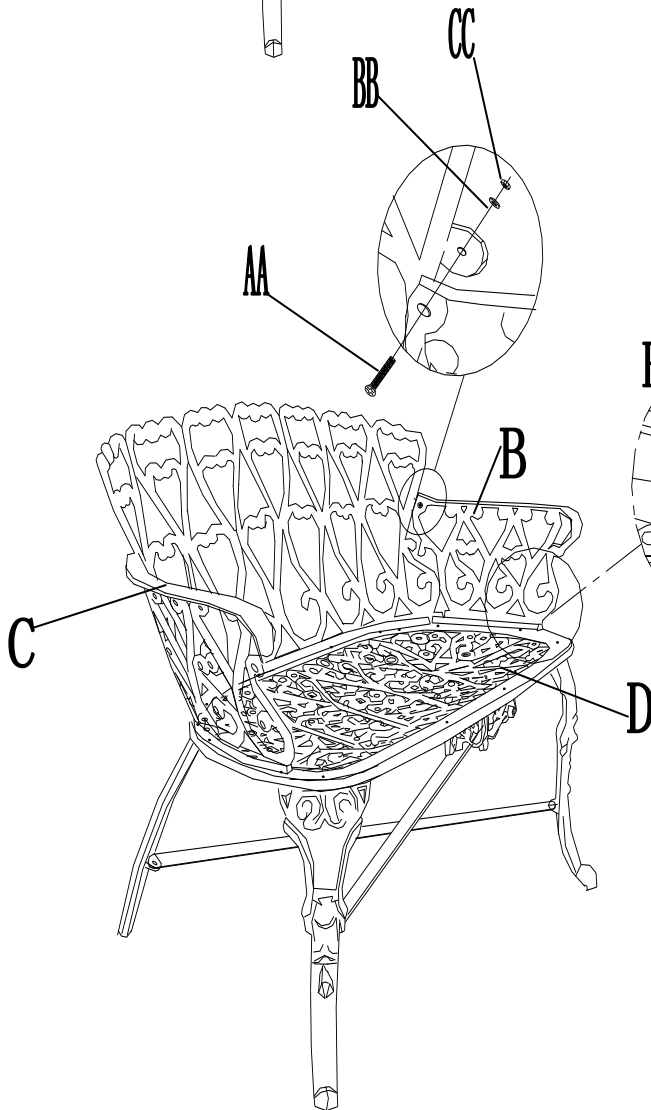

Step 4: Attach bottom of armrest (B), (C) to seat (D) with bolt (AA) spring washer (BB), lock and tighten by nut (CC) using wench (DD) and Philips-screwdriver. Attach side of armrest (B), (C) to back (A) with bolt (AA) and spring washer (BB), secure and tighten by (CC) using wench (DD) and Philips-screwdriver.



Now your Set is ready for use.

Limited Warranty:

This product carries a one (1) year warranty against defects in workmanship and materials.

Important: For technical assistance on assembly or replacement parts. In the continental U.S., you can call us toll-free at 1-866-578-6569 from 8 a.m. to 5 p.m. CST Monday – Friday. In the continental Canada, you can call us toll-free at 1-844-SUNJOY1 (1-844-786-5691) from 8 a.m. to 5 p.m. CST Monday – Friday. You can fax the replacement part form which is in the box to (740)-283-3549 .You can also send us an email to customer.care@sunjoydirect.com.The manufacturer reserves the right to repair or replace the defective product, at its discretion.

Made in China