

STERLING FANS

MODEL: SE80T SE90T SE110
 SE120 SE150

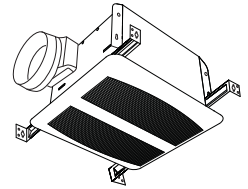

WARNING

WARNING -TO REDUCE THE RISK OF FIRE, ELECTRIC SHOCK, OR INJURY TO PERSONS, OBSERVE THE FOLLOWING:

- a). Use this unit only in the manner intended by the manufacturer. If you have questions, contact the manufacturer.
- b). Before servicing or cleaning unit, switch power off at service panel and lock the service disconnecting means to prevent power from being switching on accidentally. When the service disconnecting means cannot be locked, securely fasten a prominent warning device, such as a tag, to the service panel.
- c). Installation work and electrical wiring must be done by a qualified person(s) in accordance with all applicable codes and standards, including fire-rated construction codes and standards.
- d). Sufficient air is needed for proper combustion and exhausting of gases through the flue (chimney) of fuel burning equipment to prevent backdrafting. Follow the heating equipment manufacturer's guideline and safety standards such as those published by the National Fire Protection Association (NFPA), and the American Society for Heating, Refrigeration and Air Conditioning Engineers (ASHRAE), and the local code authorities.
- e). When cutting or drilling into wall or ceiling, do not damage electrical wiring and other hidden utilities.
- f). Ducted fans must always be vented to the outdoors.
- g). Acceptable for use over a tub or shower when connected to a GFCI (Ground Fault Circuit Interrupter) - protected branch circuit (ceiling installation only).
- h). This unit must be grounded.
- i). Not for Use in Kitchens.
- j). To reduce risk of fire and to properly exhaust air, be sure to duct air outside – Do not vent exhaust air into spaces within walls or ceilings or into attics, crawl spaces, or garages.
- k). **WARNING: To Reduce The Risk Of Fire Or Electric Shock, Do Not Use This Fan With Any Solid-State Speed Control Device.**
- l). The fan must not be installed in a ceiling thermally insulated to a value greater R40.

CAUTION

- 1. For general ventilating use only. Do not use to exhaust hazardous or explosive materials and vapors.
- 2. This product is designed for installation in ceilings up to a 12/12 pitch (45 degree angle). Duct connector must point up. **DO NOT MOUNT THIS PRODUCT IN A WALL.**
- 3. To avoid motor bearing damage and noisy and/or unbalanced impellers, keep drywall spray, construction dust, etc. off power unit.
- 4. Please read specification label on product for further information and requirements.
*The manual in electronic format can be download in our company web, or obtained from our dealer.

CLEANING & MAINTENANCE

For quiet and efficient operation, long life, and attractive appearance - lower or remove grille and vacuum interior of unit with the dusting brush attachment. The motor is permanently lubricated and never needs oiling. If the motor bearings are making excessive or unusual noises, replace the motor with the exact service motor. The impeller should also be replaced.

OPERATION

Use an on/off switch to operate this fan. See "Connect Wiring" for details.

READ AND SAVE THESE INSTRUCTIONS
Installer: Leave this manual with the homeowner.

PLAN THE INSTALLATION

1. Do not use in a cooking area.
2. Two ways to connect ductwork to a factory-shipped unit.

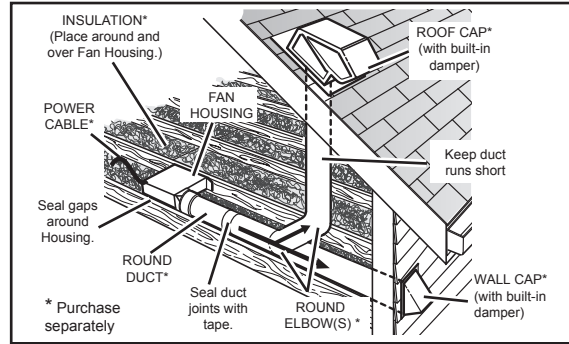
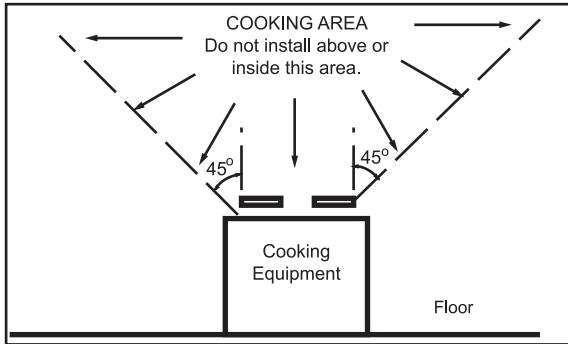

TYPES OF TYPICAL INSTALLATIONS

1. Housing mounted to I-joists (Start at "ASSEMBLY INSTRUCTIONS 1")
2. Housing mounted to joists (Start at "ASSEMBLY INSTRUCTIONS 1")
3. Housing mounted to truss (Start at step "ASSEMBLY INSTRUCTIONS 2")

ASSEMBLY INSTRUCTIONS

1. MOUNT HOUSING TO JOIST OR I-JOIST.

Hold the housing so that it is in contact with the bottom of the joist. Attach the housing with four (4) screws to the joist through the holes in each mounting flange.

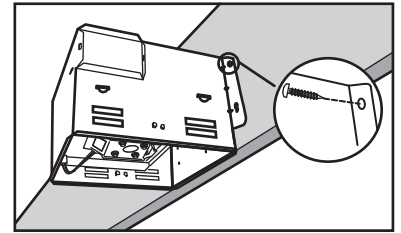

2. MOUNT WITH HANGER BARS

2a. Sliding hanger bars have been provided, which allow the housing to be positioned accurately anywhere between the framing. The bars span up to 24 in. and can be used on all types of framing: I-joist, standard joist, and truss construction. Slide hanger bars onto housing and adjust as needed to fit between framing.

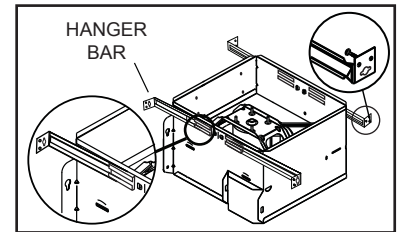

2b. Extend the hanger bars to the width of the framing. Position the ventilator with the hanger bar tabs wrapped around the bottom edge of the framing, holding the ventilator in place. Secure hanger bars to framing using one screw on each end of hanger bar. Select a proper hole and secure the hanger bars together using flange screws.

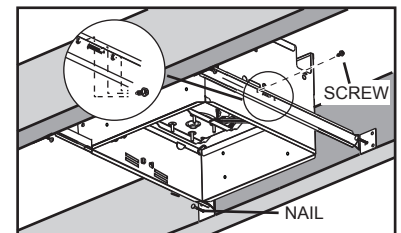

3. ATTACH DAMPER/DUCT CONNECTOR

Snap the damper/duct connector onto the fan housing. The connector must be flush with the top of the housing, and the damper flap should fall closed. Insulated flexible duct is recommended for the quietest possible installation. If rigid duct is used, a short (1-3 feet) section of insulated flexible duct will ensure quiet operation.

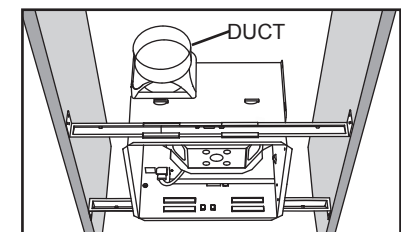

ASSEMBLY INSTRUCTIONS

4. INSTALL ROUND DUCTWORK

Connect the round ductwork (not included) to the damper/duct connector, and run the ductwork to a roof or wall cap (not included). Using tape (not included), secure all the ductwork connections so that they are air tight.

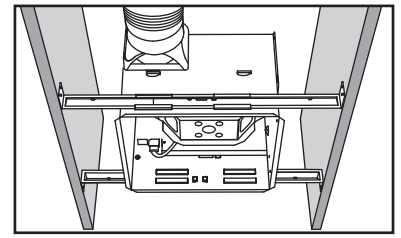

CONNECT ELECTRICAL WIRING

Run 120 V AC house wiring to the location of the fan. Use only UL-approved connectors (not included) to attach the house wiring to the wiring plate. Refer to the wiring diagram, and connect the wires as shown.

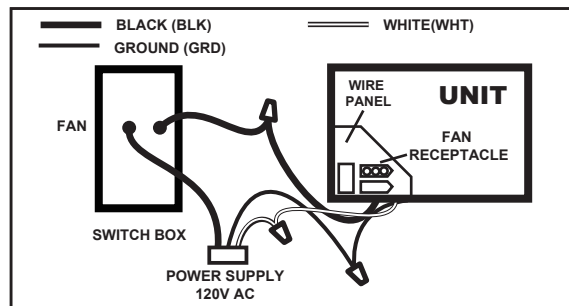
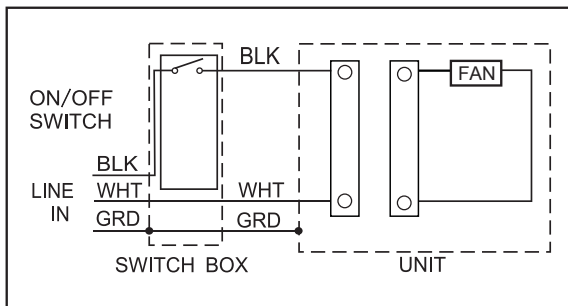

INSTALL GRILLE

Install ceiling material to complete the ceiling construction. Then, cut around the fan housing.

To attach the grille assembly to the fan housing, pinch the grille springs on the sides of the grille assembly, and position the grille into the housing with the grille springs in the appropriate slots. Push the grille assembly towards the ceiling to secure.

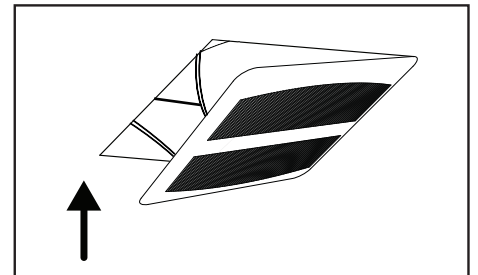

SERVICE PARTS

PART	PART NAME	Qty.
1	Grille Assembly (includes part 2)	1
2	Grille Spring	2
3	Motor Plate	1
4	Motor	1
5	Blower Wheel	1
6	Wire Panel / Harness Assembly	1
7	Wiring plate	1
8	Housing	1
9	Hanger Bar Kit	4
10	Damper / Duct Connector	1
a	Nut, Hex Lock	4
b	Washer	4
c	Screw	1
d	Isolator	4
e	Screw	1

* Blower Assembly includes part 5, 4, d, 3, c, b, a.

Replacement installation:

Remove the screw (part c), then take out the motor plate (part 3) from the housing (part 8) by pushing down the rib in the plate while pulling out on the side of the housing. Replace the broken parts.

WARNING: Ensure that the fan is switched off from the supply mains before replacing.

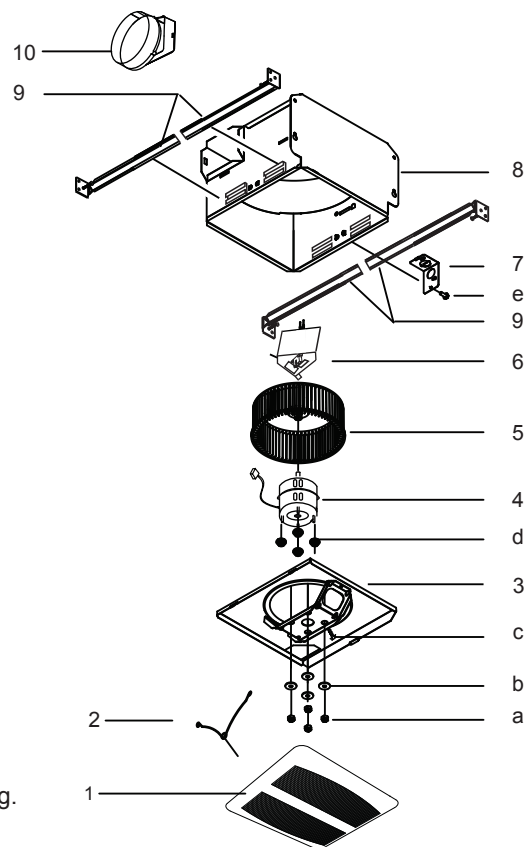

WARRANTY

This warranty covers all defects in workmanship or materials for:

The mechanical and electrical parts contained in this product, for a period of 12 months, from the date of purchase. You must keep and be able to provide your original sales receipt as proof of the date of purchase. This warranty is covered the original retail purchaser of this product. The manufacturer will repair or replace, in your home, any mechanical or electrical part which proves defective in normal household use for a period of 12 months.

THIS WARRANTY DOES NOT COVER:

- Damages from improper installation
- Damages from shipping
- Damages from misuse, abuse, accident, alteration, lack of proper care and maintenance
- Damages from service by persons other than an authorized dealer or service center.
- Labor, service, transportation and shipping charges for the removal of defective parts and for installation of a replacement part, beyond the initial 12-month period.

This warranty does not extend to fluorescent lamp starters and tubes.

THIS LIMITED WARRANTY IS GIVEN IN LIEU OF ALL OTHER WARRANTIES, EXPRESSED OR IMPLIED, INCLUDING THE WARRANTIES OF MERCHANTABILITY AND FITNESS FOR A PARTICULAR PURPOSE.

The remedy provided in this warranty is exclusive and is granted in lieu of all other remedies. This warranty does not cover incidental or consequential damages. Some states do not allow the exclusion of incidental or consequential damages, so this limitation may not apply to you. Some states do not allow limitations on how long an implied warranty lasts, so this limitation may not apply to you. This warranty gives you specific legal rights, and you may also have other rights, which vary from state to state.