

Elite Air Massage Walk In Bathtub



A3107 Left Hand Door



A3108 Right Hand Door

Specifications

Actual Size: 29.75" W x 52.25" L x 38" H

Shipping Size: 34" W x 57" L x 46" H

Shipping Weight: 250 lbs.

Net Weight: 150 lbs.

Water Capacity:

80 gal. US (unoccupied)

45-65 gal. US (occupied)

Options

- Left or Right Hand Door/Drain

Included Features

Tub Shell – Acrylic Tub Shell:

- High quality cast acrylic
- Excellent color uniformity
- High gloss white finish
- Fiberglass reinforced

1. Stainless Steel Frame
2. Unique removable swivel tray (patented) Two (2) front, one (1) toe kick and one (1) side removable access panels
3. Removable rubber back support (white)
4. Wall extension kit to fit in standard 60" opening
5. Low threshold step in 8" with the option to lower to 5"
6. Seat Width: 21.75"
7. Eight (8) adjustable heavy duty leveling legs
8. Stainless steel and tempered glass door, door frame and door seal gasket
9. Removable door for easy cleaning
10. Air Massage System (4.5 amp) (480 W)
 - Sixteen (16) therapeutic air massage jets with blackflow valve
 - Variable speed pump with auto purge

11. Five-piece thermostatic faucet set

- Thermostatic control valve
- Two (2) 2-way diverters with extension handles
- Pull out, hand held, chrome plated shower with 5 ft. retractable stainless steel braided hose

Plumbing

- Two (2) x 2" floor drains with 2 overflows and 2 ADA compliant stainless steel cable operated openers with extension handles
- Drainage time +/- 80 seconds to overflow
- Two (2) PVC 2" drain elbows with 2" opening

Warranty

- Lifetime limited warranty on frame, door, door seal gasket and acrylic walk in tub shell
- Five (5) Year parts warranty*
- Thermostatic Control Valve (TCV) 1 year limited warranty

*For more information please visit www.ellasbubbles.com

Elite Air Massage Walk In Bathtub

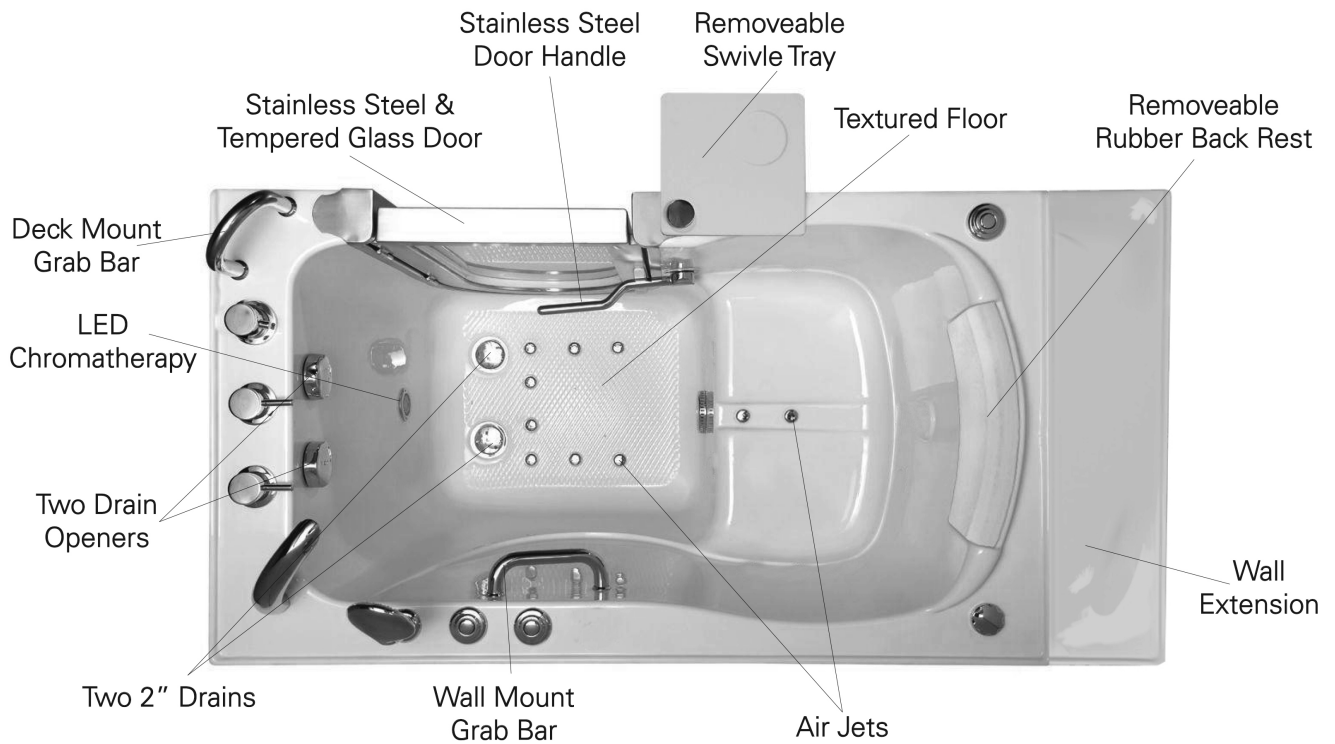

Panel On



Panel Off



Lowered Threshold



Baseboard On
(not supplied)

Elite Air Massage Walk In Bathtub

*Right hand door and drain shown

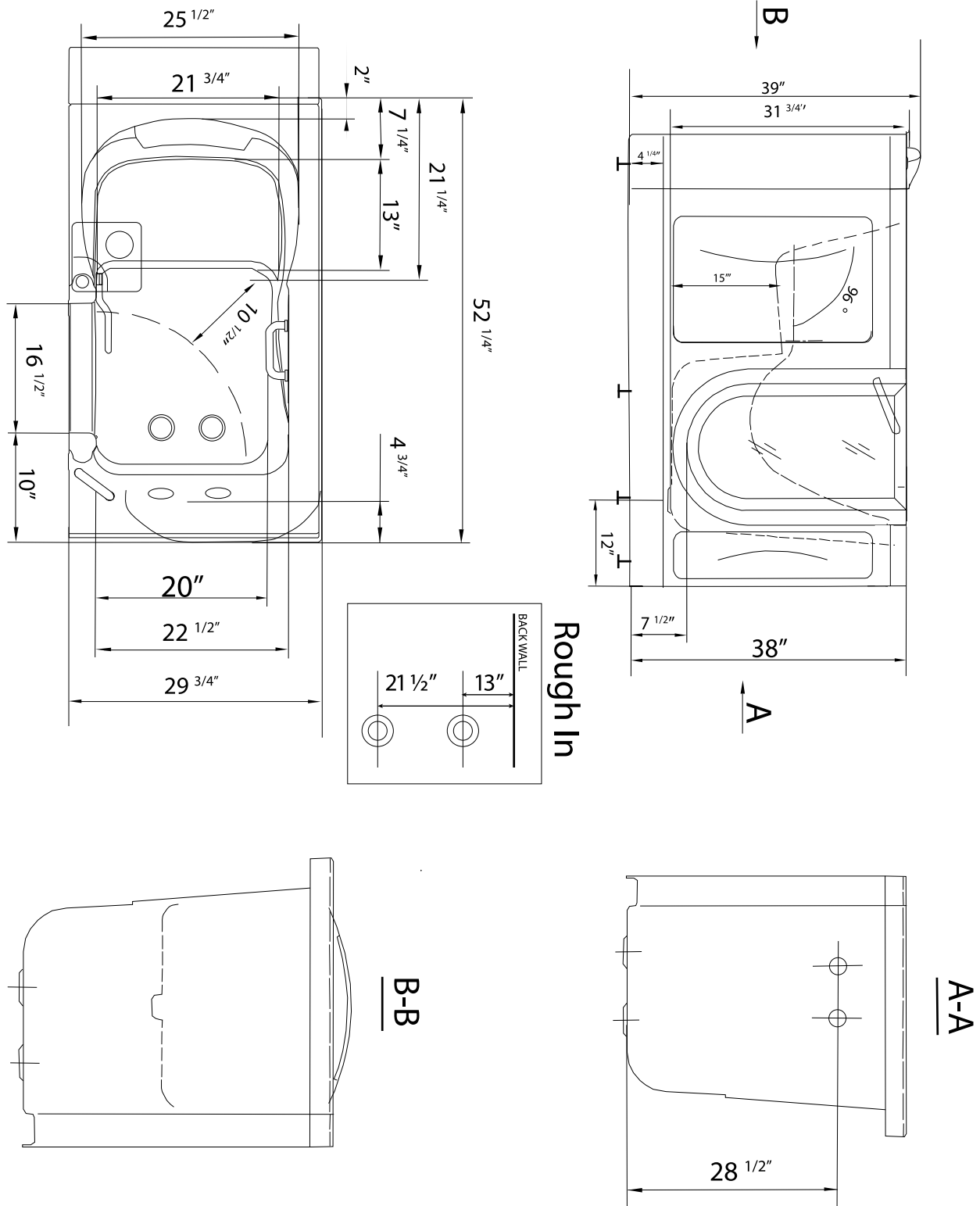

Disclaimer:

In an effort to continually improve our product, specifications and configurations are subject to change without notice. Before ordering or installing, consider future access to essential equipment.