

Model XSS02Z Parts List

A = Standard Equipment

O = Circuit Diagram

Item#	Part#	Description	Q'ty	Unit
001	265995-6	TAPPING SCREW 4X18	5	PC.
002	141472-1	HANDLE COVER COMPLETE	1	PC.
003	651976-0	SWITCH TG73BD	1	PC.
004	231469-9	COMPRESSION SPRING 4	1	PC.
005	419664-3	LOCK OFF LEVER	1	PC.
007	231469-9	COMPRESSION SPRING 4	1	PC.
009	644808-8	TERMINAL	1	PC.
010	419665-1	SWITCH LEVER	1	PC.
011	265995-6	TAPPING SCREW 4X18	2	PC.
012	419281-9	REAR COVER	1	PC.
013	643829-7	HOLDER CAP	2	PC.
014	CB441	CARBON BRUSH CB-441 (195022-4)	1	SET
015	911263-2	PAN HEAD SCREW M5X40	3	PC.
016	643897-0	BRUSH HOLDER	1	PC.
017	643898-8	BRUSH HOLDER	1	PC.
018	815L52-8	XSS02 NAME PLATE	1	
019	142597-4	MOTOR HOUSING COMPLETE	1	
	C10	803K44-3 CAUTION LABEL	1	
020	638571-3	YOKE UNIT	1	PC.
021	419285-1	BAFFLE PLATE	1	PC.
022	266292-3	TAPPING SCREW 4X65	2	PC.
023	210045-2	BALL BEARING 627DDW	1	PC.
024	510095-0	ARMATURE ASS'Y 18V	1	PC.
	D10	INC. 23,25,26		
025	241869-5	FAN 55	1	PC.
026	211061-7	BALL BEARING 6000LLB	1	PC.
027	346059-6	SHAFT LOCK	1	PC.
028	233092-6	COMPRESSION SPRING 5	1	PC.
031	142596-6	BLADE CASE COMPLETE	1	
	C10	213434-0 O RING 26	1	PC.
	C20	802U29-6 CAUTION LABEL	1	
033	262049-0	RUBBER RING 6	1	PC.
034	251368-9	+ COUNTERSUNK SCREW M6	1	PC.
035	210028-2	BALL BEARING 606ZZ	1	PC.
036	961052-5	RETAINING RING S-12	1	PC.
037	227156-6	SPUR GEAR 52	1	PC.
038	257173-2	RING 12	1	PC.
039	213512-6	O RING 39	1	PC.
040	265034-2	+ COUNTERSUNK HEAD SCREW M5X16	2	PC.
041	318009-1	BEARING BOX	1	PC.
042	210109-2	BALL BEARING 6001DDW	1	PC.
043	324626-7	SPINDLE	1	PC.
044	285845-9	BEARING RETAINER 19-29	1	PC.
045	345469-4	THICKNESS RING	1	PC.
046	231821-1	TENSION SPRING 3	1	PC.
047	419280-1	SAFETY COVER	1	PC.
048	961152-1	RETAINING RING (EXT) S-34	1	PC.
049	224411-7	INNER FLANGE 35	1	PC.
050	224409-4	OUTER FLANGE 35	1	PC.
051	266133-3	HEX. SOCKET HEAD BOLT M6X20	1	PC.

056	961014-3	STOP RING E-8	1 PC.
057	272229-0	LEVER 40	1 PC.
058	252158-3	HEX.NUT M6	1 PC.
059	941151-9	FLAT WASHER 6	1 PC.
060	345658-1	DEPTH GUIDE	1 PC.
061	252103-8	HEX. LOCK NUT M5-8	1 PC.
062	345657-3	ANGULAR GUIDE	1 PC.
065	265056-2	+ PAN HEAD SCREW M5	1 PC.
066	266194-3	FLAT HEAD SCREW M6X90	1 PC.
067	256480-0	SHOULDER PIN 6-7	1 PC.
068	256480-0	SHOULDER PIN 6-7	1 PC.
069	266264-8	H.S.SET SCREW(FLAT POINT)M5X6	1 PC.
070	251919-8	CAP SQUARE NECK BOLT M6X20	1 PC.
071	231007-7	COMPRESSION SPRING 6	1 PC.
072	251896-4	SCREW M5X20	1 PC.
073	941151-9	FLAT WASHER 6	1 PC.
076	252133-9	HEX. NUT M6	1 PC.
077	961014-3	STOP RING E-8	1 PC.
078	272251-7	LEVER 30	1 PC.
079	266264-8	H.S.SET SCREW(FLAT POINT)M5X6	1 PC.
081	154831-0	BASE COMPLETE	1 PC.
082	266229-0	H.S.SET SCREW(CUP POINT)M5X8	1 PC.
085	253186-1	FLAT WASHER 7	1 PC.
A01	164095-8	GUIDE RULE	1 PC.
A05	783203-8	HEX. WRENCH 5	1 PC.
A08-1	A-96023	T.C.T SAW BLADE 165X15.88X16T	1 PC.
E01	620259-9	CONTROLLER	1

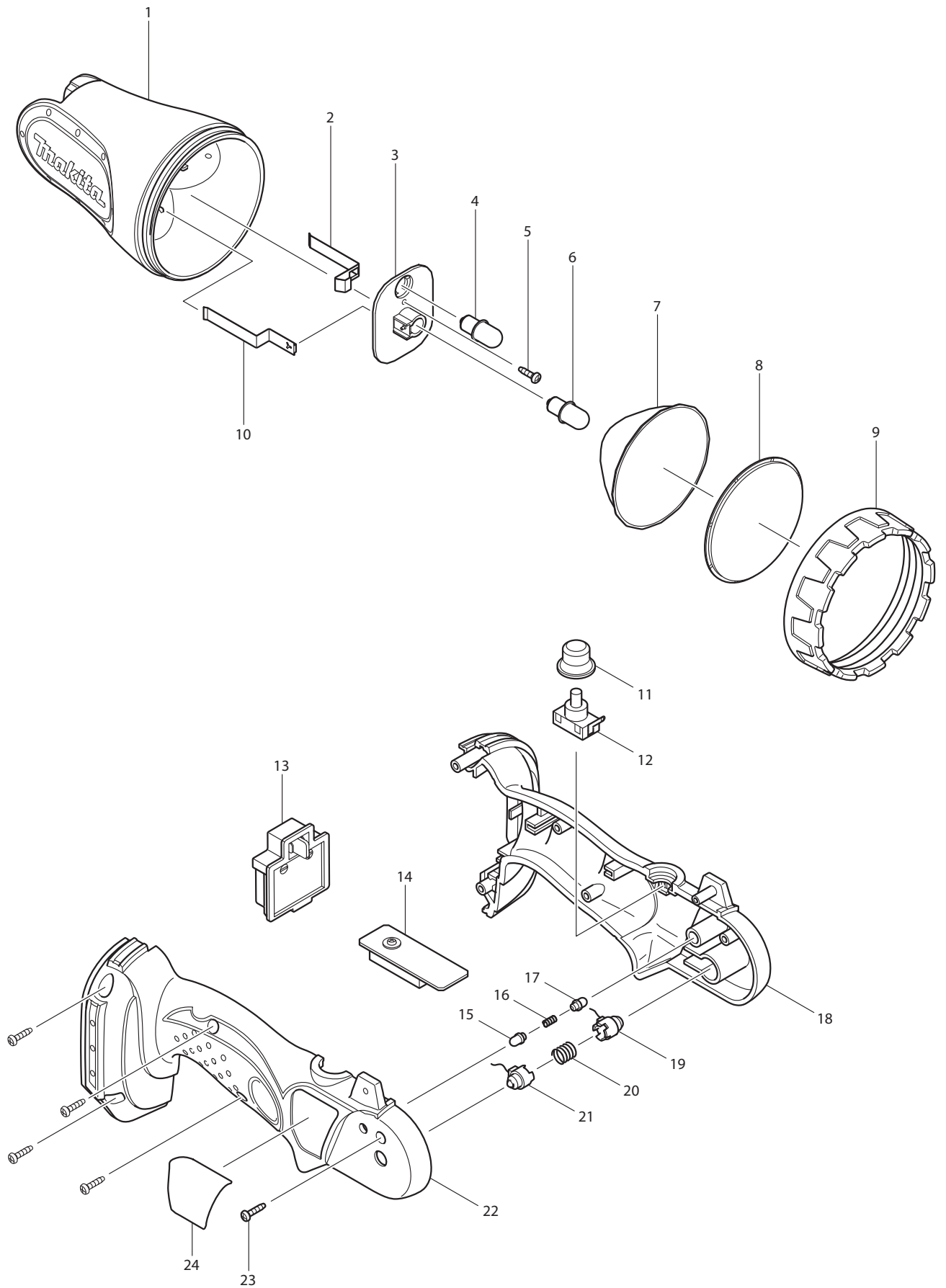

Model DML185/W Parts List

A = Standard Equipment

O = Circuit Diagram

Item#	Part#	Description	Q'ty	Unit
001	GM00001003	CASE HEAD 30105185104	1	PC. DML185
	GM00001120	CASE HEAD	1	PC. DML185W
002	GM00001010	BULB CONTACT PLATE-21201185002	1	PC.
003	GM00001002	PROTECTOR(CONTACT)32009120012	1	PC.
004	A-90261	BULB SET	1	SET
005	GM00001012	SCREW 3X12 PB BLACK ZN	1	PC.
006	A-90261	BULB SET	1	SET
007	GM00000130	REFLECTOR	1	PC.
008	GM00000070	LENS	1	PC.
009	GM00001001	REFLECTOR RETAINER 30110185003	1	PC.
010	GM00001009	BULB CONTACT PLATE (+)	1	PC.
011	GM00001006	RUBBER COVER 39010185004	1	PC.
012	GM00000200	SWITCH	1	PC.
013	GM00001116	BATTERY HOLDER (C2004185006)	1	PC.
014	GM00001029	CIRCUIT BOARD G0318500100	1	PC.
015	GM00001005	KNOCK SHAFT 31011120009	1	PC.
016	GM00000090	COMPRESSION SPRING 4	1	PC.
017	GM00001005	KNOCK SHAFT 31011120009	1	PC.
018	GM00001000	HOUSING SET	1	SET DML185
	GM00001056	HOUSING SET G0318500303	1	SET DML185W
	D10	INC. 22		
019	GM00001004	LEFT CASE SHAFT 3101012003	1	PC.
020	233144-3	COMPRESSION SPRING 7	1	PC.
021	632524-4	PIVOT TERMINAL UNIT R	1	PC.
022	GM00001000	HOUSING SET	1	SET DML185
	GM00001056	HOUSING SET G0318500303	1	SET DML185W
	D10	INC. 18		
023	GM00001013	SCREW 3X14 PB BLACK ZN	5	PC.
024	GM00001454	NAME PLATE	1	PC.
E01	810320-2	CAUTION LABEL	1	PC.

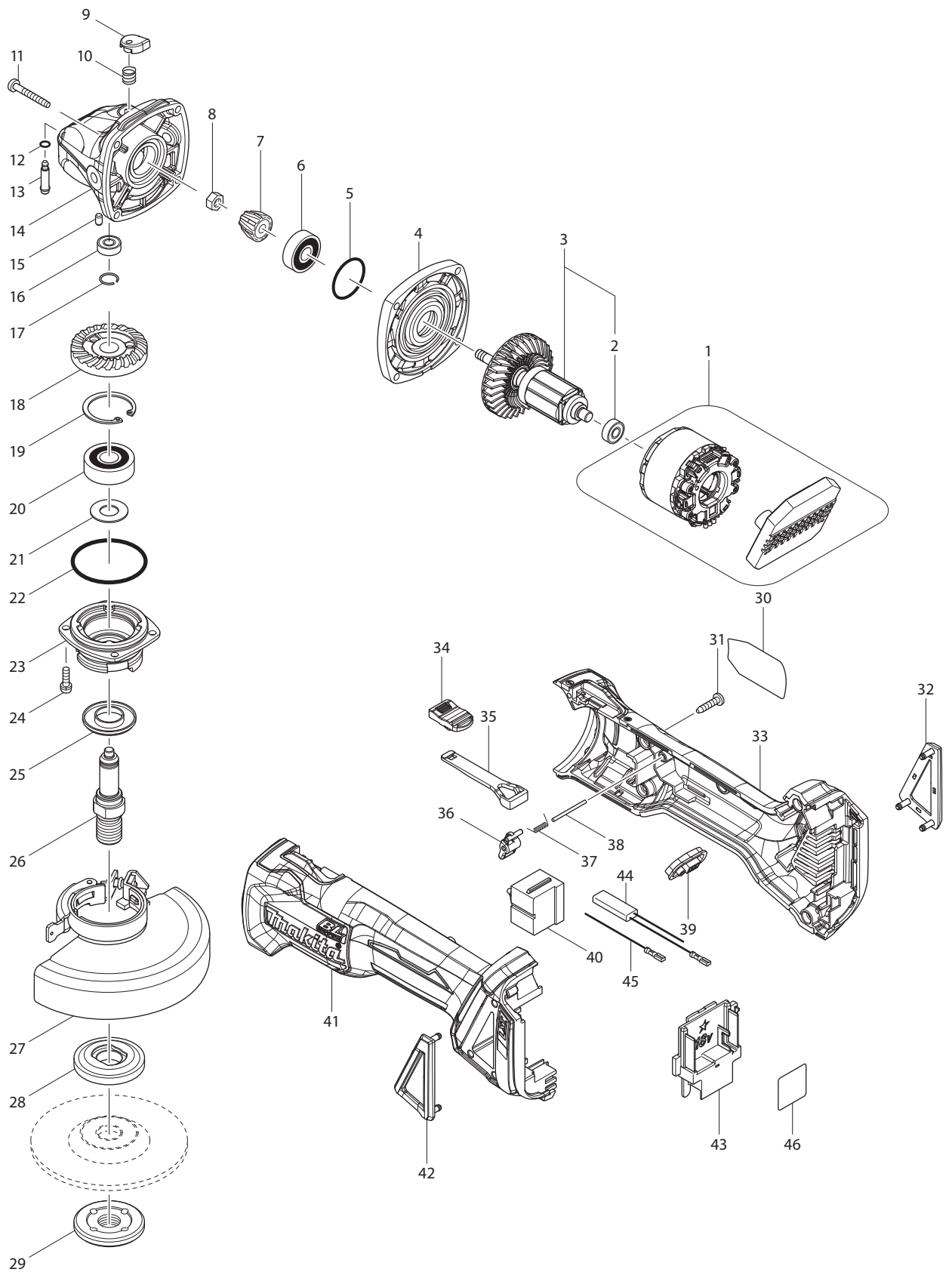

Model XAG03Z Parts List

A = Standard Equipment

O = Circuit Diagram

Item#	Part#	Description	Q'ty	Unit	
001	629134-6	STATOR COMPLETE	1	PC.	
002	210034-7	BALL BEARING 607LLB	1	PC.	
003	519354-9	ROTOR ASS'Y	1		
	D10	INC. 2			
004	319214-3	GEAR HOUSING COVER	1		
005	213445-5	O-RING 26	1	PC.	
006	210042-8	BALL BEARING 629LLB	1	PC.	
007	227541-3	SPIRAL BEVEL GEAR 10	1	PC.	
008	252186-8	HEX. NUT M6	1	PC.	
009	417771-6	PIN CAP	1	PC.	
010	233072-2	COMPRESSION SPRING 8	1	PC.	
011	266361-0	TAPPING SCREW 4X30	4	PC.	
012	213960-9	O RING 5	1	PC.	
013	256546-6	SHOULDER PIN 4	1	PC.	
014	319213-5	GEAR HOUSING	1		
015	263002-9	RUBBER PIN 4	1	PC.	
016	210033-9	BALL BEARING 696ZZ	1	PC.	
017	233950-6	RING SPRING 11	1	PC.	
018	227641-9	SPIRAL BEVEL GEAR 37	1		
019	962151-6	RETAINING RING R-32	1	PC.	
020	211129-9	BALL BEARING 6201DDW	1	PC.	
021	267113-2	FLAT WASHER 12	1	PC.	
022	213622-9	O RING 45	1	PC.	
023	318331-6	BEARING BOX	1	PC.	
024	911121-2	PAN HEAD SCREW M4X14	4	PC.	
025	345464-4	LABYRINTH RING	1	PC.	
026	324955-8	SPINDLE A	1	PC.	
027	123144-0	TOOLLESS WHEELCOVER 115AK ASSY	1	PC.	
	C10	213009-5	O RING 4	1	PC.
	C20	265180-1	PAN HEAD SCREW M5X16	1	PC.
028	224399-1	INNER FLANGE 45	1	PC.	
029	224568-4	LOCK NUT 5/8-45	1	PC.	
030	850J28-6	XAG03 NAME PLATE	1		
031	266326-2	TAPPING SCREW 4X18	5	PC.	
032	455450-8	DUST COVER R	1		
033	187998-9	MOTOR HOUSING SET	1		
	C10	263005-3	RUBBER PIN 6	2	PC.
	D10	INC. 41			
034	455447-7	SWITCH KNOB	1		
035	455446-9	SWITCH LEVER	1		
036	455448-5	LEVER	1		
037	231679-8	TORSION SPRING 2	1		
038	268330-7	PIN 2	1		
039	142901-7	INDICATOR PANEL COMPLETE	1		
040	650579-7	SWITCH 1246.3223	1	PC.	
041	187998-9	MOTOR HOUSING SET	1		
	C10	263005-3	RUBBER PIN 6	2	PC.
	D10	INC. 33			
042	455449-3	DUST COVER L	1		
043	643899-6	TERMINAL	1	PC.	
044	632E34-1	RESISTOR UNIT	1	PC.	
045	632E33-3	LEAD UNIT	1	PC.	

046	850J33-3	XAG03 SERIAL NO. LABEL	1
A01	122910-2	WHEEL COVER 115CK ASSEMBLY	1 PC.
	C10 213009-5	O RING 4	1 PC.
	C20 265180-1	PAN HEAD SCREW M5X16	1 PC.
A02	158237-4	GRIP 36 COMPLETE	1 PC.
A03	782424-9	LOCK NUT WRENCH 28	1 PC.
A04	A-95956	INOX GRINDING WHEEL 115MM	1 PC.
A05	724115-A-25	THIN CUTTING 115	1 PC.
E01	805C42-5	CAUTION LABEL	1
D01	652044-2	+BIND SCREW M3.5X5.0	2 PC.
D02	654509-0	CONNECTOR 2-SD	1 PC.

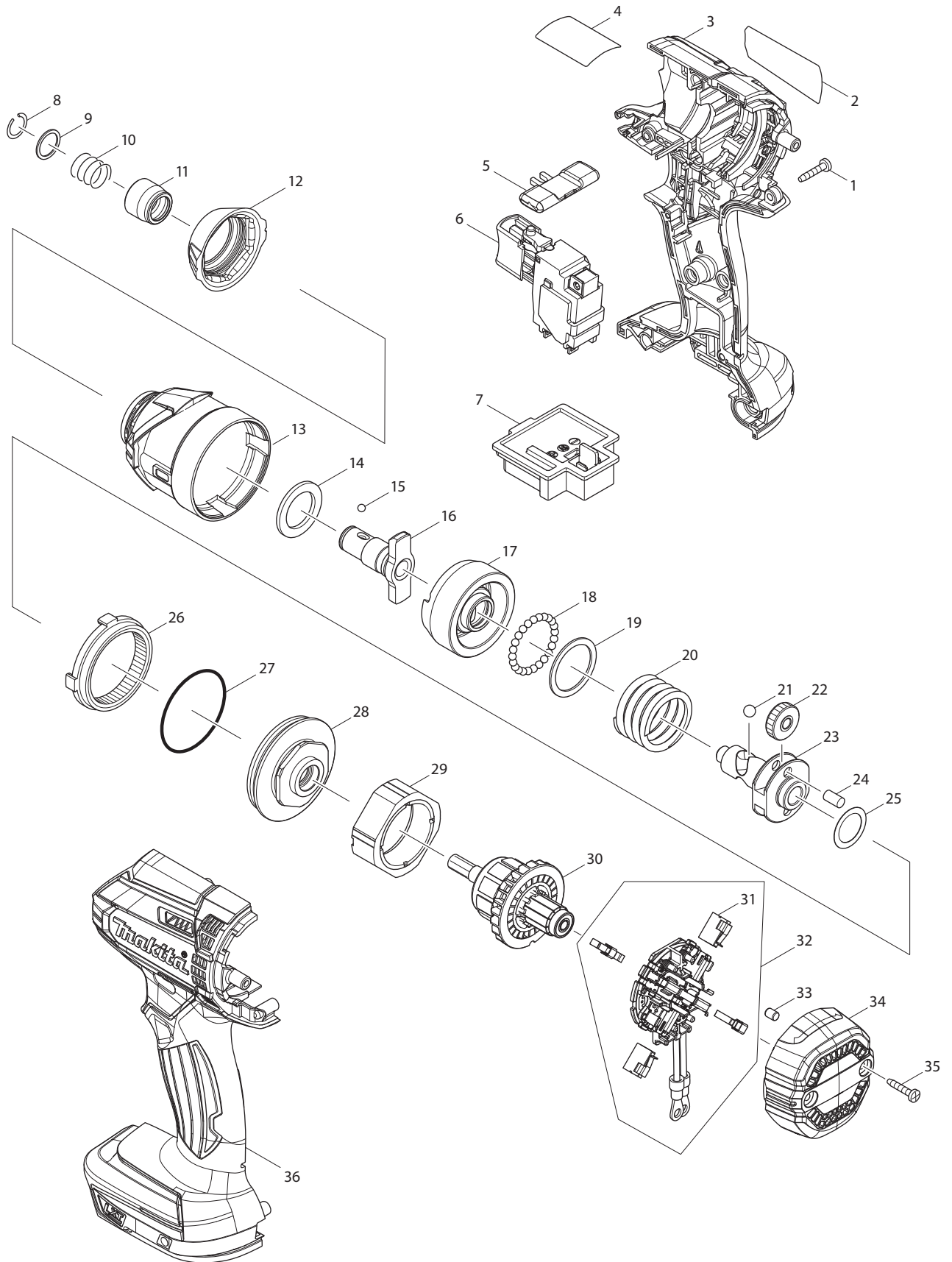

Model XDT11R Parts list

A = Standard Equipment

O= Circuit Diagram

Item#	Part#	Description	Q'ty	Unit
001	266429-2	TAPPING SCREW 3X16	8	PC.
002	851E28-9	XDT11 NAME PLATE	1	
003	183B63-4	HOUSING SET	1	
	C10 263005-3	RUBBER PIN 6	2	PC.
	D10	INC. 36		
004	806W83-4	CAUTION LABEL	1	
005	455053-8	F/R CHANGE LEVER	1	PC.
006	650751-1	SWITCH	1	
	C10 620445-2	LED CIRCUIT	1	
007	643852-2	TERMINAL	1	PC.
008	231951-8	RING SPRING 11	1	PC.
009	267085-1	FLAT WASHER 12	1	PC.
010	233005-7	COMPRESSION SPRING 13	1	PC.
011	326068-1	BIT SLEEVE	1	PC.
012	424738-7	BUMPER	1	
013	143299-5	HAMMER CASE COMPLETE	1	
014	261151-6	NYLON WASHER 19	1	PC.
015	216040-0	STEEL BALL 3.5	2	PC.
016	326563-1	ANVIL M	1	
017	326564-9	HAMMER	1	
018	216040-0	STEEL BALL 3.5	24	PC.
019	267175-0	FLAT WASHER 24	1	PC.
020	234251-5	COMPRESSION SPRING 25	1	PC.
021	216041-8	STEEL BALL 5.6	2	
022	227362-3	SPUR GEAR 22	2	PC.
023	326562-3	SPINDLE	1	
024	256253-1	PIN 5	2	PC.
025	253314-8	THIN WASHER 15	1	PC.
026	227378-8	INTERNAL GEAR 51	1	
027	213507-9	O RING 40	1	PC.
028	143298-7	BEARING BOX COMPLETE	1	
029	638396-5	YOKE UNIT	1	PC.
030	619377-8	ARMATURE	1	
031	CB448	CARBON BRUSH CB-448 (196855-0)	2	
032	632F23-2	BRUSH HOLDER COMPLETE	1	
	D10	INC. 31		
033	263032-0	RUBBER PIN 4	4	PC.
034	456044-2	REAR COVER	1	
035	266429-2	TAPPING SCREW 3X16	2	PC.
036	183B63-4	HOUSING SET	1	
	C10 263005-3	RUBBER PIN 6	2	PC.
	D10	INC. 3		
A01	346449-3	HOOK	1	PC.
A02	266622-8	+ TRUSS HEAD SCREW M4X12	1	PC.
A03	141856-3	PLASTIC CARRYING CASE COMPLETE	1	PC. (XDT11R)
	C10 162302-3	LATCH	2	PC. (XDT11R)
	C20 324207-7	SHAFT	1	PC. (XDT11R)
	C30 451749-9	HANDLE	1	PC. (XDT11R)
A04	450128-8	BATTERY COVER	1	PC. (XDT11R)
A05	***DC18RC	DC18RC FAST CHARGER	1	PC. (XDT11R)
A06	BL1820B	BATTERY BL1820B SET	2	(XDT11R)
D01	652045-0	+PAN HEAD SCREW M3.5X5	2	PC.

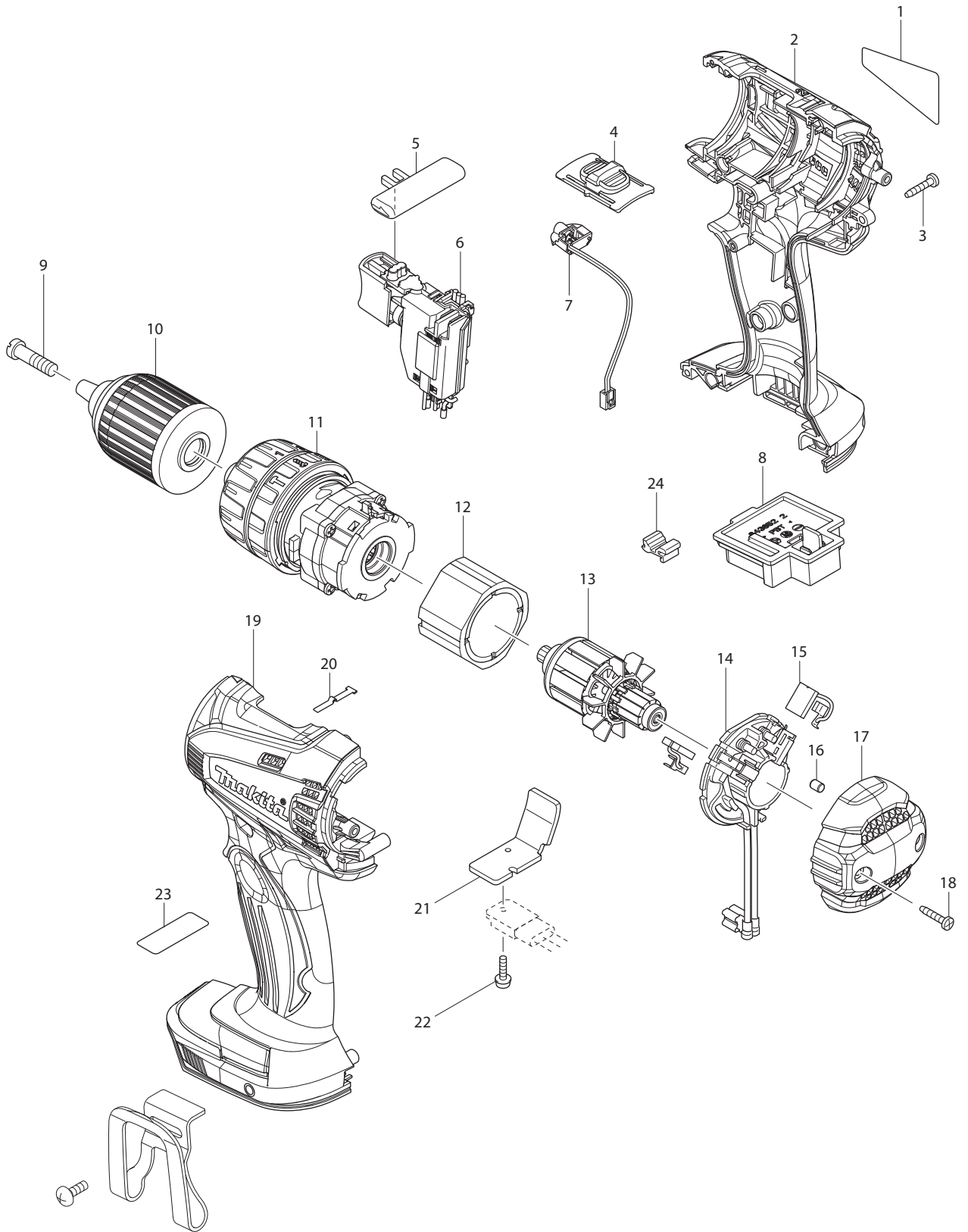

Model XPH01,XPH01CW,XPH01RW,XPH01Z Parts List

A = Standard Equipment

O = Circuit Diagram

Item#	Part#	Description	Q'ty	Unit
001	815C82-5	XPH01 NAME PLATE	1	XPH01, XPH01Z
	802R26-4	XPH01CW NAME PLATE	1	XPH01CW
	804V36-1	XPH01RW NAME PLATE	1	XPH01RW
002	188971-2	HOUSING SET	1 PC.	XPH01, XPH01Z
	188970-4	HOUSING SET	1 PC.	XPH01CW, XPH01RW
	C10 263005-3	RUBBER PIN 6	2 PC.	
	D10	INC. 19		
003	266429-2	TAPPING SCREW 3X16	9 PC.	
004	126289-3	SPEED CHANGE LEVER ASSEMBLY	1 PC.	
	C10 233438-6	COMPRESSION SPRING 4	2 PC.	
005	419250-0	F/R CHANGE LEVER	1 PC.	
006	650731-7	SWITCH C3HZ-1A-TLMS	1	
007	620012-3	LED CIRCUIT	1 PC.	
008	643852-2	TERMINAL	1 PC.	
009	251468-5	- FLAT HEAD SCREW M6X22	1 PC.	
010	766008-1	KEYLESS DRILL CHUCK 13	1 PC.	
011	126460-9	GEAR ASSEMBLY	1	
012	638425-4	YOKE UNIT	1 PC.	
013	619263-3	ARMATURE	1 PC.	
014	638494-5	BRUSH HOLDER COMPLETE	1 PC.	
015	CB440	CARBON BRUSH CB-440 (195021-6)	1 SET	
016	263032-0	RUBBER PIN 4	2 PC.	
017	452205-2	REAR COVER	1 PC.	XPH01, XPH01Z
	452202-8	REAR COVER	1 PC.	XPH01CW, XPH01RW
018	266429-2	TAPPING SCREW 3X16	2 PC.	
019	188971-2	HOUSING SET	1 PC.	XPH01, XPH01Z
	188970-4	HOUSING SET	1 PC.	XPH01CW, XPH01RW
	C10 263005-3	RUBBER PIN 6	2 PC.	
	D10	INC. 2		
020	232182-2	LEAF SPRING	1 PC.	
021	689170-4	HEAT SINK	1 PC.	
022	911013-5	PAN HEAD SCREW M3X10	1 PC.	
023	802P77-5	CAUTION LABEL	1	
024	424476-1	CUSHION	1 PC.	
A01	251314-2	+ SCREW M4X12	1 PC.	XPH01, XPH01CW, XPH01RW
A02	346449-3	HOOK	1 PC.	XPH01, XPH01CW, XPH01RW
A03	784637-8	+ - BIT 2-45	1 PC.	XPH01, XPH01CW, XPH01RW
A04	142146-7	PLASTIC CASE COMPLETE	1 PC.	XPH01
	141856-3	PLASTIC CASE COMPLETE	1 PC.	XPH01CW, XPH01RW
	C10 162302-3	LATCH	2 PC.	XPH01CW, XPH01RW
	C20 324207-7	SHAFT	1 PC.	XPH01CW, XPH01RW
	C30 451749-9	HANDLE	1 PC.	XPH01CW, XPH01RW
A05	450128-8	BATTERY COVER	1 PC.	XPH01, XPH01CW
A06	***DC18RC	DC18RC FAST CHARGER	1 PC.	XPH01, XPH01CW, XPH01RW
A07	BL1830	BATTERY BL1830 SET	2 SET	XPH01
	BL1815	BATTERY BL1815 SET		XPH01CW
	BL1820	BATTERY BL1820 SET		XPH01RW