



Mechanical Filter Box

Up to 500 gallons

ITEM #FM002

REMINDER
CALL 1-888-755-6750
BEFORE RETURNING TO STORE.



Questions, problems, missing parts? Before returning to your retailer, call our customer service department at 1-888-755-6750, 8 a.m.-6 p.m., EST, Monday-Friday, or email us at customer@thepondboss.net. Or visit our website www.thepondboss.net.

PACKAGE CONTENTS

Part	Description	Quantity
A	Filter box top	1
B	Filter box bottom	1
C	Coarse filter pad	1
D	Fine filter pad	1
E	Bio media balls	10

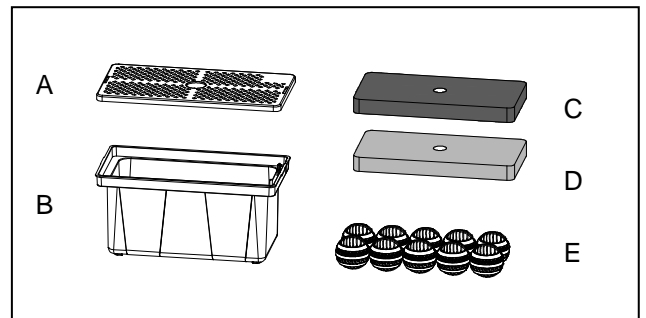

PREPARATION

Before beginning assembly of product, make sure all parts are present. Compare parts with package contents list and diagram above. If any part is missing or damaged, do not attempt to assemble, install or operate the product. Contact customer service for replacement parts.

- Estimated Assembly Time: 15 minutes
- No tools required for assembly.

PRODUCT DESCRIPTION

The FM002 is a general purpose, mechanical / biological filter system. It is designed to filter the water and promote healthy bacteria that will provide a balanced environment in your pond. This filter is designed to work with a water pump that can circulate a minimum of 200 gallons per hour. As a pre-filter, the FM002 reduces pond debris and particulate before they enter the pump and other pond accessories. This pre-filtration reduces the clogging of your pump and accessories and minimizes the need for cleaning.

ASSEMBLY INSTRUCTIONS

1. Place your pump inside the filter box, close to the center. Make sure that the outlet points up. Route the cord through the hole in the top corner of the filter box bottom. Fig. 1

NOTE: Pump is NOT INCLUDED. This filter is compatible with pump models PF320, PF525, PP225, PP350 and PP575.

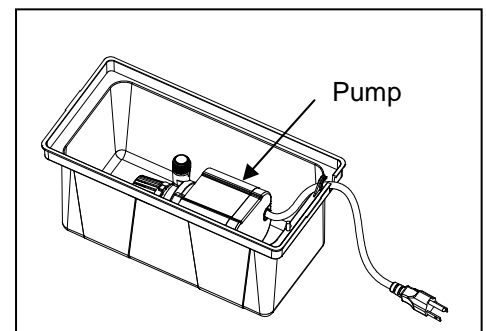

Fig. 1



PLEASE CALL 1-888-755-6750 BEFORE RETURNING TO THE STORE.
WWW.THEPONDBOSS.NET

2. Place the bio-balls around the pump. Fig. 2

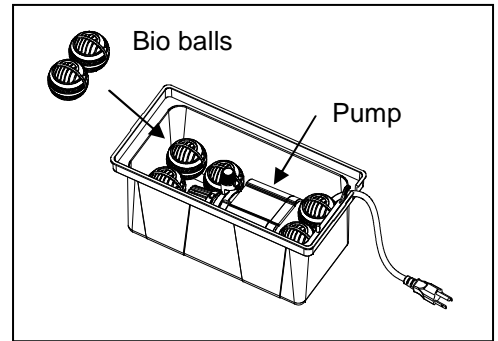

Fig. 2

3. Connect the extension tube to the outlet of the pump using the adapter (adapter is part of fountain head kit). Fig. 3

NOTE: Fountain head kit (item #NLFTN) is NOT INCLUDED, and is not required for operation.

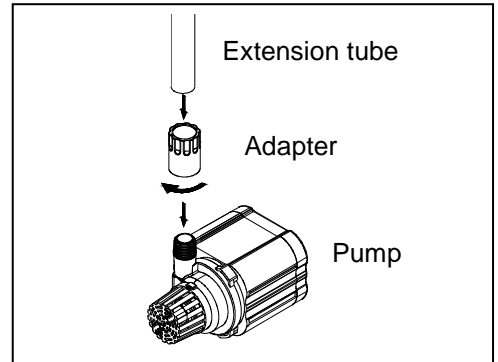

Fig. 3

4. Place one of the fine filter pads over the bio-balls and pump. Then place one of the coarse filter pads over the fine filter pad. Fig. 4

NOTE: The fine filter pad is blue and the coarse filter pad is black.

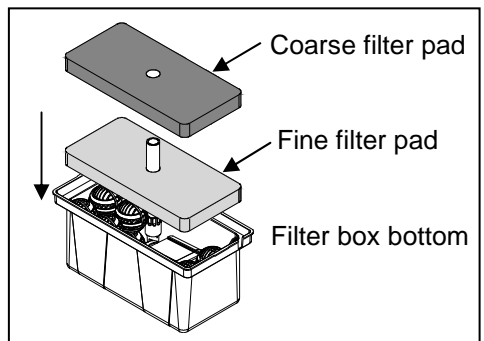

Fig. 4

NOTE: From here, a coupler or a diverter valve can be used.

- a. To flow water to the fountain head only, use the coupler. (Proceed to step 5)
- b. To flow water to the fountain head and a spitter, use the diverter. (Skip to step 8)



**PLEASE CALL 1-888-755-6750 BEFORE RETURNING TO THE STORE.
WWW.THEPONDBOSS.NET**

5. Connect the two extension tubes with the coupler. Fig. 5

NOTE: Extension tubes and coupler are NOT INCLUDED.

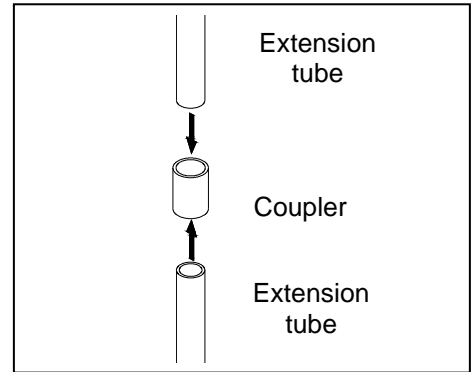

Fig. 5

6. Place the filter box top over the filter box bottom and connect the fountain head to the top extension tube. Fig. 6

NOTE: Fountain head kit is NOT INCLUDED.

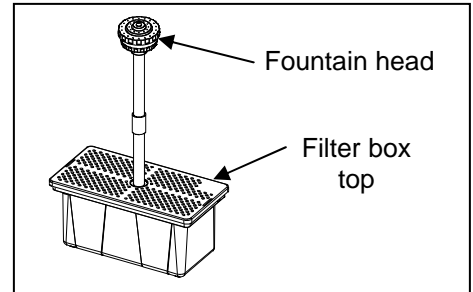

Fig. 6

7. Place the filter assembly in the water. Fig. 7

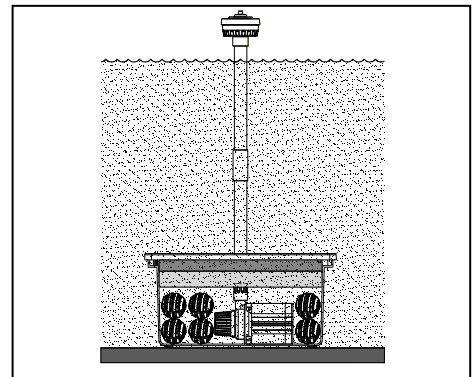

Fig. 7

8. Place the filter box top on top of the filter box bottom. It should snap closed. Fig. 8

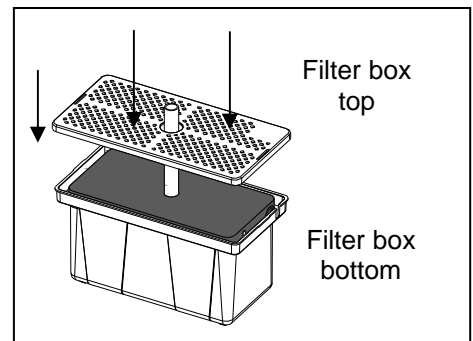

Fig. 8



PLEASE CALL 1-888-755-6750 BEFORE RETURNING TO THE STORE.
WWW.THEPONDBOSS.NET

9. Connect the extension tubes to the diverter valve. Make sure the arrow on the valve is positioned as shown and the diverter valve is connected as shown. Fig. 9

NOTE 1: Tubes and diverter valve are NOT INCLUDED.

NOTE 2: Use diverter valve to simultaneously run a spitter and fountain head from one pump.

NOTE 3: If you have a pump that uses 3/4 in. tubing and you want to divert flow, purchase an extra Diverter Valve model #NDIV.

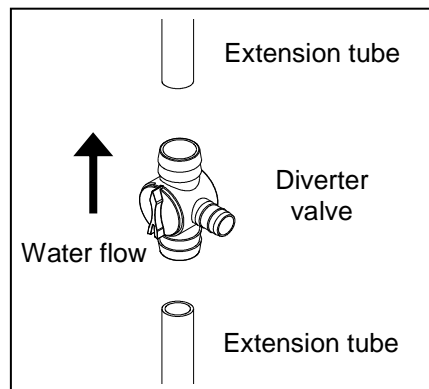

Fig. 9

10. For 1/2 in. tubing, connect the tubing onto the second output of the diverter. Connect the other end of the tubing to a spitter or other water feature. Fig. 10

NOTE: Tubing, diverter valve, and adapter are NOT INCLUDED.

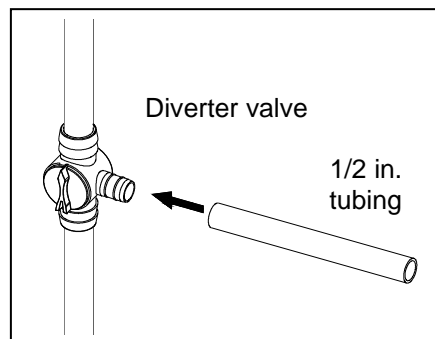

Fig. 10

11. Connect the fountain head to the top extension tube. Adjust the diverter valve to split the flow between the fountain head and the spitter. Fig. 11

NOTE: Fountain head kit is NOT INCLUDED.

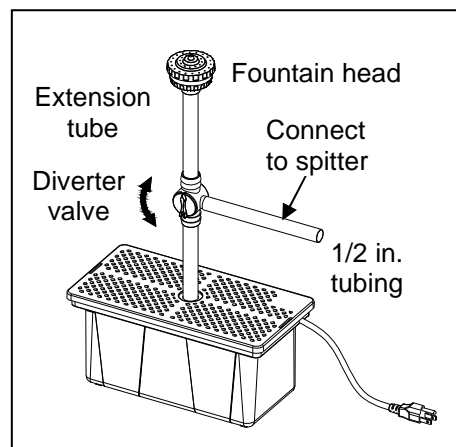

Fig. 11



12. Place the filter assembly in the water. Fig. 12

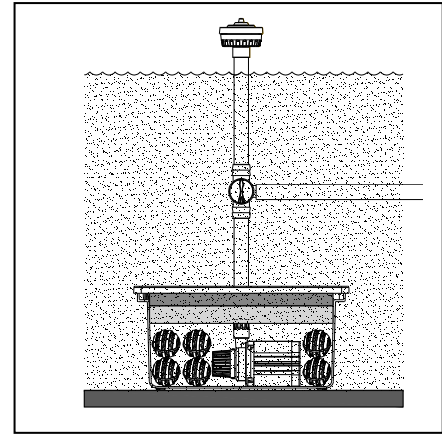

Fig. 12

CARE AND MAINTENANCE

- Occasional cleaning of the filter pads will be necessary to ensure the proper functioning of the system. The coarse filter pad is designed to trap large debris. The fine filter pad catches smaller particles. All pads should be removed and washed with clean water when they are visibly soiled.
- Filter pads should be replaced annually. The exterior surface of the filter box may also need occasional cleaning. Particularly if the openings in the top of the filter box are obstructed. When cleaning the filter box use warm water only. Do not use any chemicals that may destroy the beneficial bacteria.
- The bio media balls in your filter system and the inside surfaces of the filter box contain the beneficial bacteria. At least once a year the entire system should be disassembled and cleaned thoroughly using warm, soapy water (mild detergent). This should not be done during the warm season as it may take up to 8 weeks to re-establish the environmental balance. The best time of the year to “breakdown” your system is in early spring before the water temperatures begin to rise. This is also the ideal time to replace the filter pads.

REPLACEMENT PARTS LIST

For replacement parts, call our customer service department at 1-888-755-6750, 8 a.m.-6 p.m., EST, Monday-Friday, or email us at customercare@thepondboss.net.

Part	Description
A	Filter box top
B	Filter box bottom

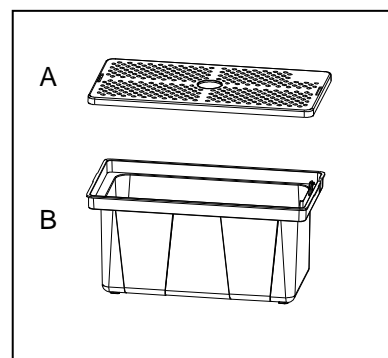

Printed in China



PLEASE CALL 1-888-755-6750 BEFORE RETURNING TO THE STORE.
WWW.THEPONDBOSS.NET

LIMITED WARRANTY

All pumps and electrical products are warranted to the user against defective material and workmanship, under normal working conditions. This warranty period begins on the date of purchase by the original purchaser.

Unless otherwise specified all pond boss® electrical products are warranted to the user against defective material and workmanship, under normal working conditions for 1 year from the date of purchase.

- Pond and Waterfall pumps are warranted for 3 years.
- All pond boss® liners are warranted to the user against defective workmanship, under normal working conditions for 20 years from the date of purchase.
- All other pond boss® products are warranted to the user against defective material and workmanship, under normal working conditions for 90 days.

Application

Warranty covers only properly installed and maintained units. Any damage to the cord or modification to the unit will invalidate the warranty. Pump warranty is limited to applications pumping fresh water in a pond or fountain only. Other liquid applications or extreme temperature uses must be approved in writing by the manufacturer. Receipt and product date code are required for warranty claims.

Warranty Claim

Warranty claims must be made by calling customer service (at 1-888-755-6750). If the item is determined to be defective, you will be given authorization to return the defective part(s), freight pre-paid, along with proof of purchase.

Disposition

The manufacturer will make a good faith effort for prompt disposition regarding all warranty claims. Returned product will be inspected to determine cause of failure before warranty is applied. Warranty does not cover any costs associated with the shipping, handling, installation or removal of products or parts subject to this warranty. For products damaged in transit, a claim should be filed with the carrier.

Disclaimer

Any oral statements made about the product by the seller, the manufacturer, the representatives, or any other parties do not constitute warranties, should not be relied upon by the user, and are not part of the contract for sale. The seller's and manufacturer's only obligation, and buyer's only remedy shall be for the manufacturer to either replace and/or repair at the manufacturer's sole discretion, the product as described above. Neither seller nor the manufacturer shall be liable for injury, loss or damages for lost profits, lost sales, injury to person or property, or any other incidental or consequential loss arising from any cause whatsoever, no matter whether based upon warranty, contract, negligence or other misuse, and the buyer and user agree that no other remedy shall be available to them. Before using, the buyer and user shall determine the suitability of the product for the intended use, and assume all risk and liability whatsoever in connection therewith. The warranty and remedy described in this limited warranty is an exclusive warranty and remedy in lieu of any other warranty or remedy expressed or implied. All other warranties and remedies are hereby expressly excluded, including but not limited to any implied warranty of merchantability of fitness for any particular purpose. This warranty gives the buyer and user specific legal rights, and buyer and user may also have other rights which vary from state to state. Some states do not allow exclusions or limitations of incidental or consequential damages, so the above limitations or exclusions may not apply to you.

REMINDER
CALL 1-888-755-6750
BEFORE RETURNING TO STORE.



PLEASE CALL 1-888-755-6750 BEFORE RETURNING TO THE STORE.
WWW.THEPONDBOSS.NET