

HIGH-EFFICIENCY FURNACES

Built Exclusively for Manufactured Housing

- Proven components.
- reliable
- Appliance finish.
- looks great
- Fully insulated cabinets.
- quiet

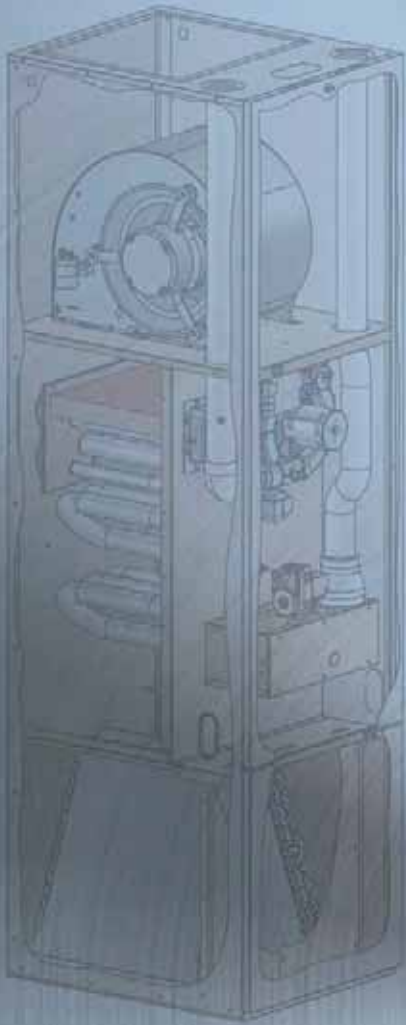

Miller is a household name.

Miller is a household name in the manufactured housing industry, with over 92 years of experience. Given our history and dedication to the manufactured housing industry, it is easy to see why most new manufactured homes are built with our heating systems, and when needed, are equipped with our cooling systems too. You can rely on your Miller comfort expert to make your home cozy with digital thermostats and other manufactured home accessories. You can have it all: clean air at the perfect temperature!

Exclusively made for the manufactured home.



Today, the manufactured home is a sophisticated, affordable home that is a smart choice for many buyers. Equally smart is knowing that your manufactured home furnace is just that – a *manufactured home* furnace. Specifically designed for your manufactured home, a Miller furnace offers high efficiency and system dependability.

Comfort you can rely on.

The more you learn how we design and build your heating and cooling system, the more you'll see that no other heating and cooling manufacturer compares to Miller's product quality – quality made possible through **Demand Flow Technology**. While other companies test products at random, we use 100% computer-automated testing on every Miller product to eliminate human error. We are the only heating and cooling manufacturer to be DFT certified.

It's a comfort to know that Miller is made for your manufactured home, and it's a comfort you can feel.

What is AFUE?

Annual Fuel Utilization Efficiency is the term used to rate the efficiency levels of a Gas or Oil furnace. The higher the AFUE rating the more energy efficient your system is and the lower your energy costs will be. It measures the amount of heat actually delivered to your house compared to the amount of fuel that you supply to the furnace. Thus, a furnace that has an 95% AFUE rating converts 95% of the fuel that you supply to heat - the other 5% is lost out of the chimney. Compare this to an older furnace that may only deliver 60% efficiency.

If installed in SCAQMD only: The furnaces in this literature do not meet the SCAQMD Rule 1111 14 ng/J NOx emission limit (14 ng/J), and thus are subject to a mitigation fee of up to \$450.

These furnaces are not eligible for the Clean Air Furnace Rebate Program: www.CleanAirFurnaceRebate.com.

Multi-speed direct drive blower (MG2R Models)

Fixed-speed blower (MG2S Models)

Two-pipe system for flexible installations

Stainless steel secondary heat exchanger

Aluminized steel primary heat exchanger

Two-stage gas valve (MG2S models)

Fully insulated cabinet

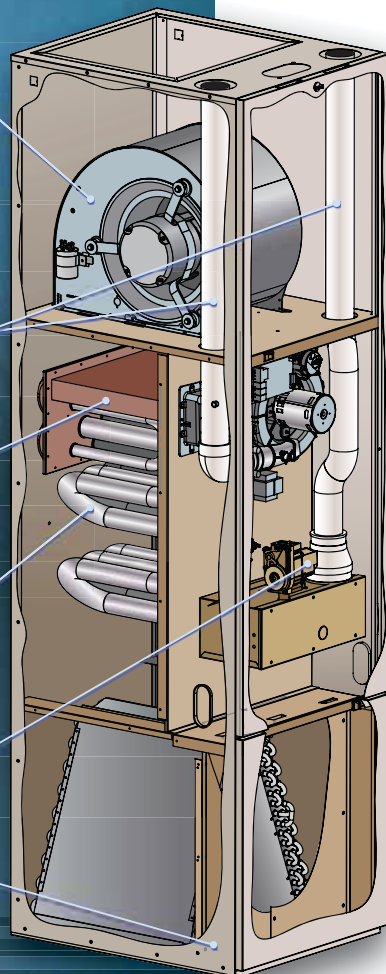

Model MG2R

95% & 96% AFUE

Extra High-Efficiency MG2R and MG2S Gas Furnaces

Products for the
Manufactured Home

The only 96% AFUE furnace that fits a standard 20" manufactured housing footprint.

- Models with coil cabinet for shorter cooling coils.
- Models without coil cabinet integrated for cooling applications that need separate taller cooling coils.
- Extremely efficient for lower gas bills. May qualify for local rebates and incentives.
- Dependable silicone-nitride hot surface igniter utilizes proven SmartLite® technology for longer igniter life.
- Stainless steel secondary heat exchanger for a long life.
- May be vertically or horizontally vented using a two-pipe system for maximum flexibility in installation.
- Can use old chimney as chase for new vent piping with accessory kit.
- Fully insulated cabinet minimizes heat loss and provides quiet operation.
- Diagnostic lights provide easy troubleshooting.

Additional features on MG2S 96% AFUE Miller two-stage, fixed-speed gas furnace models:

- Two-stage gas valve – provides low heat operation during mild outdoor temperatures.
- Fixed-speed blower provides wide range of cooling and heating airflows.
- Optimal staging on ignition board allows operation with a single-stage thermostat.

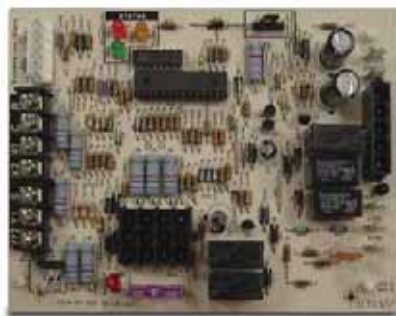

SmartLite CONTROL BOARD

Innovative hot surface igniter and control board design ensures longer igniter life.

*Model MG2
Front Return*



Model MG2 Top Return

*Model MG2 Front Return
without coil*



*Model MG2 Top Return
without coil*

95.1% & 80% AFUE High-Efficiency CMF Gas & Oil Furnaces

80% AFUE gas/oil furnaces use proven components to ensure high quality and dependability.

- New door switch design means less chance of damage when opening door.
- Disposable paper air filter, no need for cleaning. Provides better filtering and cleaner air in the home.
- Tilt out door with no hinges for easier serviceability and filter access.
- Upgraded metal latch for stability.
- More door louvers for better airflow.
- Designed most size manufactured housing applications, and space heating, garages, and hunting cabins. Ideal for tight replacement applications.
- Multi-speed blower and multi-fired burner for efficiency and long-life.
- Titanium treated aluminized steel process technology provides strength and durability to the heat exchanger for long life.
- Appliance finish protects against rust and corrosion.
- All units and each component are tested on the manufacturing line to ensure quality and safety.
- Beckett gas burners are standard.



Model
CMF3

95.1% AFUE furnace in a classic 18-inch width for tight replacement jobs.

- Heavy gauge aluminized steel heat exchanger and stainless steel secondary heat exchanger assure a long life.
- Dependable, hot surface igniter utilizes proven SmartLite® technology for longer igniter life.
- Diagnostic lights for easy troubleshooting.
- High static blowers.
- Optional - Vent termination accessory kit allows installation in a home that has an 80% AFUE furnace using a metal roof jack.

18" width for
tight installations

Multi-speed
direct drive blower

Two-pipe system
for flexible installations

Stainless steel secondary
heat exchanger

Aluminized steel
primary heat exchanger

MA 100 and CB 200 bases for
versatility in applications

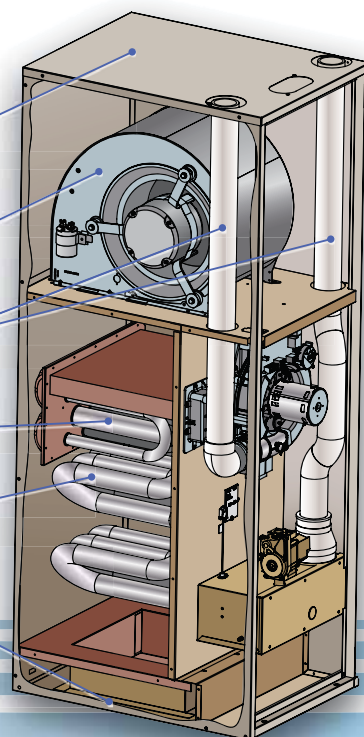

Model CMF95

Model CMF95

SmartLite
CONTROL BOARD

92.1% & 95% AFUE

Extra High-Efficiency MG3 Gas Furnaces

Proven components to ensure high quality, dependability and safety.

- Our dependable, shock-mounted hot surface ignitor has a 20 year history of reliability. It's controlled by proven SmartLite® technology to increase ignitor life by 25%.
- Heavy-gauge aluminized primary steel heat exchanger and stainless steel secondary heat exchanger ensures long life and efficiency.
- Available in both upflow and downflow models, which can be installed in a utility room or enclosed closet.
- The built-in time-delay relay increases cooling performance when matched with a Miller cooling system.
- Fully insulated cabinet provides quiet operation.
- All units and each component are tested on the manufacturing line to ensure quality, performance and safety.



Model MG3R
Downflow



Model MG3P
Upflow

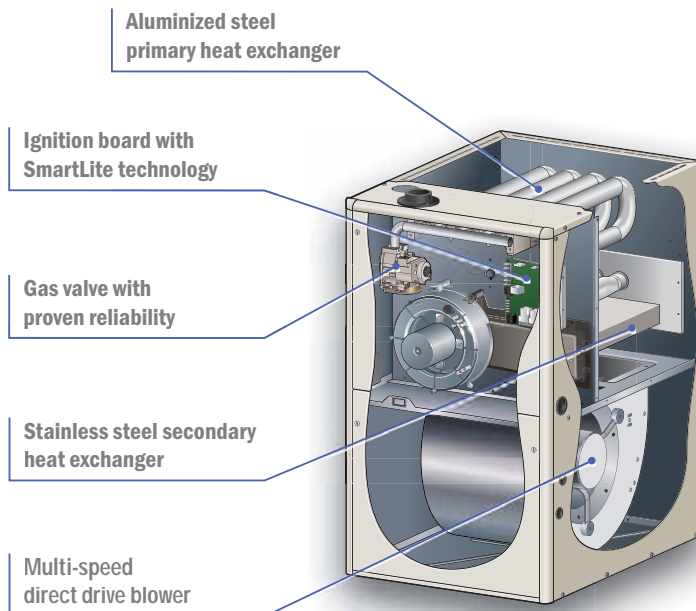

Model MG3P Upflow

Models MG1 and M5



80 & 83% AFUE

High-Efficiency MG1 Gas & M5 Oil Furnaces

Built to standard dimensions for manufactured housing:

- Models with coil cabinet for shorter cooling coils.
- Models without coil cabinet integrated for cooling applications that need separate taller cooling coils.
- Proven components ensure high quality and dependability.
- Insulated cabinet ensures minimized heat loss and quiet operation.
- All models are A/C ready with built-in blower delays. No relays needed.
- Appliance finish protects against rust and other corrosion.
- All units and each component are tested on the manufacturing line to ensure quality.

Additional features on 83% AFUE Miller M5 Oil Gun furnace models:

- Designed for all sizes of manufactured and modular homes, and can be installed in a utility room, enclosed closet or alcove.
- Heavy-gauge aluminized steel heat exchanger ensures long life and efficiency.
- Sealed combustion system vents exhaust gas directly outdoors and draws in 100% outside air for the burner.
- Easy open pawl latch secures the door firmly for transit, yet allows easy removal for access.
- Room air is cleaner with the large, effective permanent washable air filter.
- High efficiency drum heat exchanger delivers optimum heat transfer with low air resistance.
- Reliable burner with uniform flame pattern extends life of heat exchanger.

*Models MG1 and M5
without coil*

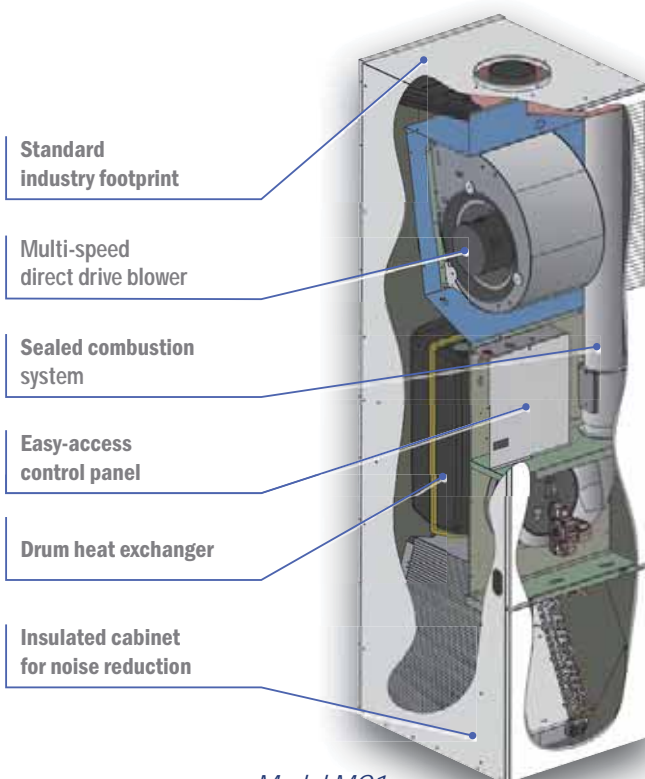

Model MG1

Electric Furnaces and Air Handlers

Miller E7 electric furnaces:

- Factory installed heater kits are UL compliant.
- Optimal cooling comfort ensured with 16 cooling speeds.
- Integrated cooling blower delay.
- Proven components ensure high quality, dependability and safety.
- Designed for all sizes of manufactured housing applications - fits easily in an enclosed closet or alcove.
- Multi-speed blowers increase air movement to circulate heat in a large, multi-section home.
- Appliance finish protects against rust and other corrosion.
- All units and each component are tested on the manufacturing line to ensure quality.
- Multiple configurations for upflow and downflow applications.
- AC ready to 5 tons, HP ready to 4 tons.
- Many accessories to enhance and accommodate most installations.
- Scannable QR code for easier access to up-to-date literature.
- Dedicated upflow and downflow electric furnaces with integrated coil cabinet for taller, high efficient cooling coils.



Model E7EM

Model E7ED Downflow



*Model
E7EU
Upflow*

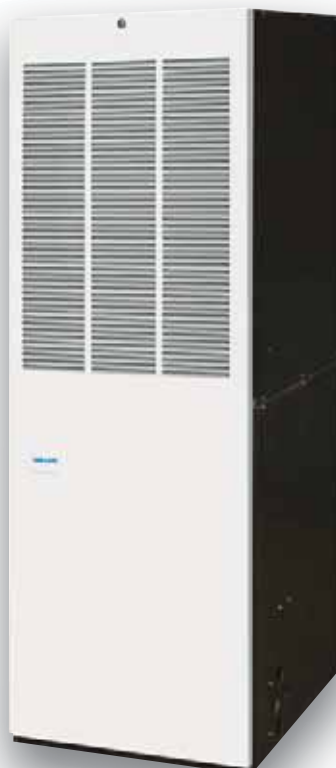

Products for the
Manufactured Home

Miller Warranty Information

Miller heating and cooling products for manufactured housing carry a one-year warranty on parts and a 5-year compressor warranty.

- **1-Year Limited Parts**
- **5-Year Limited Compressor**

Extend your standard condenser 1-year limited parts to a 5-year or 10-year limited parts by registering at www.nortekhvaccwarranty.com. Certain models apply. See warranty document for details.

In addition to the 1-year warranty, Miller gas/electric packaged systems and furnaces offer a 10-year limited warranty on heat exchangers. MG2 and CMF furnaces offer a 20-year limited warranty on heat exchangers.

Contact your Miller contractor for specific warranty details.

MILLER
Heating and Cooling Systems

millerac.com



Miller® trademark used under license. SmartLite® is a registered trademark of Nortek Global HVAC, LLC.
© Nortek Global HVAC LLC, 2020. All rights reserved. Specifications and illustrations subject to change without notice and without incurring obligation. Printed in U.S.A. 701E-0220

