

# Before you call for service

## Troubleshooting Tips

Save time and money! Review the chart on this page first and you may not need to call for service.

### **NO SOFT WATER – Most Common Problems:**

Check the following before calling for service:

- Not enough salt—should be at least 1/3 full.
- Bypass valve in “Bypass” position—handle should be in the “OUT” (service) position.
- Hardness setting too low. Check hardness setting and adjust. Verify hardness of supply water—from local water company, water test or call the GE Appliances Answer Center (800-952-5039 in US).
- Salt Bridge—salt solidifies above water level so that brine water is not in contact with salt. See the Breaking a Salt Bridge section.

<b>Problem</b>	<b>Possible Cause</b>	<b>What to do</b>
<b>No soft water</b>	<b>Faucet or fixture where sample was taken not plumbed to soft water. NOTE:</b> Be sure sample is from a faucet that does not mix soft and hard water. For example, a single lever kitchen faucet, if the cold side is plumbed to hard water.	<ul style="list-style-type: none"><li>• To conserve salt, the installer may have isolated some fixtures (outside faucets, toilets, etc.) from soft water. From the outlet of the water softening system, trace the water flow path, in house plumbing. If soft water is not directed to a faucet or fixture where wanted, consult a plumber.</li></ul>
	<b>No salt in the brine tank or salt bridged</b>	<ul style="list-style-type: none"><li>• Check for a salt bridge or, if the tank is empty, refill with recommended salt. Press (for 3 seconds) the RECHARGE button to start an immediate recharge and restore soft water supply.</li></ul>
	<b>External power supply unplugged at wall outlet or power cable to softener not connected. Fuse blown or circuit breaker popped on circuit to electrical outlet. Electrical outlet on a circuit that can continuously be switched off</b>	<ul style="list-style-type: none"><li>• Check for a loss of electrical power to the water softening system, due to any of these conditions and correct as needed. With the power supply restored, observe the faceplate time display and read Programming the Control section. NOTE: the electrical outlet for the softener should be live so it cannot be accidentally switched off.</li></ul>
	<b>Manual bypass valve in bypass position</b>	<ul style="list-style-type: none"><li>• Be sure the bypass valve stem is positioned properly, with the handle in the OUT position.</li></ul>
	<b>Valve drain hose pinched, plugged, elevated too high or otherwise restricted</b>	<ul style="list-style-type: none"><li>• Any restriction in the drain hose may prevent proper operation of the nozzle and venturi and reduce or prevent brine draw during recharge..</li></ul>
	<b>Nozzle and venturi dirty, incorrectly assembled or damaged</b>	<ul style="list-style-type: none"><li>• Refer to Cleaning the Nozzle and Venturi Assembly instructions. With water pressure to the water softening system off, take the nozzle assembly apart. Inspect, clean and replace as needed. Any foreign particle(s), scratches, nicks, etc. in the passages can prevent operation. Be sure holes in the gasket are centred over holes in the housing.</li></ul>

# Before you call for service

Problem	Possible Cause	What to do
Water hard sometimes	Using hot water while the water softening system is regenerating	<ul style="list-style-type: none"> <li>Avoid using hot water during water softening system recharge because the water heater will refill with hard water. See Automatic Hard Water Bypass During Recharge section.</li> </ul>
	Control HARDNESS number setting too low	<ul style="list-style-type: none"> <li>Press MODE/SET button until arrow points to HARDNESS. Be sure the number shown is the same as the actual grains per gallon hardness of your water supply. See Programming the Control section if a change in setting is needed.</li> </ul>
	Grains of hardness in your water supply have increased	<ul style="list-style-type: none"> <li>Water hardness can change over time, especially in well water. To check, have the water tested by a water analysis laboratory or call your local water department. Adjust the Hardness number setting as needed.</li> </ul>
Water feels slippery after installation of water softener	Absence of hardness minerals	<ul style="list-style-type: none"> <li>This is normal. Hardness in water gives it the abrasive feel you may have been accustomed to. The slippery feel is the clean feel of soft water..</li> </ul>
Water Softener not using any salt	Water softening system is a "demand" unit	<ul style="list-style-type: none"> <li>Does not use much salt to regenerate - very efficient.</li> </ul>
	Possible salt bridge	<ul style="list-style-type: none"> <li>See the <i>Breaking a Salt Bridge section</i>.</li> </ul>
	Possible plugged nozzle and venturi	<ul style="list-style-type: none"> <li>See the <i>Cleaning the Nozzle and Venturi Assembly section</i>.</li> </ul>
Water is blue color after water softener was installed	Acidic water in copper plumbing	<ul style="list-style-type: none"> <li>Have the water tested at once.</li> </ul>
Water softener not regenerating	Meter turbine stuck	<ul style="list-style-type: none"> <li>See the Manually Initiated Electronics Diagnostics section for troubleshooting procedures .</li> <li>Call for service.</li> </ul>
	Sensor wire not plugged into the control	<ul style="list-style-type: none"> <li>See the Manually Initiated Electronics Diagnostics section for troubleshooting procedures .</li> <li>Call for service</li> </ul>
	No power to unit	<ul style="list-style-type: none"> <li>Check the circuit breaker or fuses.</li> </ul>
	Mechanical defect	<ul style="list-style-type: none"> <li>Call for service.</li> </ul>
Cloudiness on glassware (automatic dishwashers)	Combination of soft water and too much detergent	<ul style="list-style-type: none"> <li>This is called etching and is permanent. To prevent this from happening, use less detergent if you have soft water. Wash glassware in the shortest cycle that will get them clean.</li> </ul>

# Before you call for service

Problem	Possible Cause	What to do
Excessive/high level of water in brine tank	Valve drain hose pinched, plugged, elevated too high or otherwise restricted	<ul style="list-style-type: none"> <li>A restriction in this drain hose may prevent proper operation of the nozzle and venturi and reduce or prevent brine draw during recharge.</li> </ul>
	Drain lines connected together	<ul style="list-style-type: none"> <li>Separate drain lines.</li> </ul>
	Nozzle and venturi dirty, incorrectly assembled or damaged.	<ul style="list-style-type: none"> <li>Refer to Cleaning the Nozzle and Venturi Assembly instructions. With water pressure to the water softening system off, take the nozzle assembly apart. Inspect, clean and replace as needed. Any foreign particle(s), scratches, nicks, etc. in the passages can prevent operation. Be sure holes in the gasket are centred over holes in the housing</li> </ul>
Salty tasting or brown/yellow colored water after installation	Unit not sanitized	<ul style="list-style-type: none"> <li>Complete Sanitization Procedures.</li> <li>At completion of recharge cycle (approx. 2 hours), run water from faucets to purge the salty water.</li> </ul>
	Low water pressure	Check pressure: <ul style="list-style-type: none"> <li>Drain height 8' or less, pressure should be minimum 20 psi.</li> <li>Drain height above 8', pressure should be minimum 50 psi.</li> </ul>
	Restricted drain hose	<ul style="list-style-type: none"> <li>Clean and reconnect hose.</li> <li>Check for kinks in drain line</li> </ul>
Brown/yellow colored water	Unit was idle for a period of time	<ul style="list-style-type: none"> <li>Complete the Sanitization Procedures.</li> </ul>
Resin beads showing up in drinking water	Cracked distributor or unit plumbed backwards	<ul style="list-style-type: none"> <li>Call for service.</li> </ul>
Sounds you might hear	Running water from the unit into a drain during recharge	<ul style="list-style-type: none"> <li>This is normal.</li> </ul>
Water has air bubbles and is cloudy	Air in system after installation	<ul style="list-style-type: none"> <li>Will go away after it runs for a while.</li> </ul>
Blue light Flashing		
When power applied to the system	Control needs to be programmed (a power outage may have occurred)	<ul style="list-style-type: none"> <li>See the Programming the Control section.</li> </ul>
If "DAYS TO EMPTY" is flashing	Low salt level, less than 15 days	<ul style="list-style-type: none"> <li>Fill with salt.</li> <li>Reset salt level.</li> </ul>

# Before you call for service

Problem	Possible Cause	What to do
Error Codes on Control	Wiring may have worked loose in the control	<ul style="list-style-type: none"> <li>• Unplug external power supply.</li> <li>• Remove control cover, release clips on side.</li> <li>• Check for loose/incorrect wiring connections to electronic board or switch. Reconnect as required.</li> <li>• Reassemble control cover.</li> <li>• Plug in Transformer.</li> <li>• Wait 8 minutes for Error Code to reappear.</li> <li>• If error Code reappears, call for service.</li> </ul>
If "Err" in display	Electrical problem with system	<ul style="list-style-type: none"> <li>• Call for service.</li> </ul>

## Advanced troubleshooting for service

### AUTOMATIC ELECTRONIC DIAGNOSTICS

This water softener has a self-diagnostic function for the electrical system (except into power and/or water meter). The water softener monitors electronic components and circuits for correct operation. If a malfunction occurs, an error code appears in the display.



Figure 14

While an error code appears in the display, all buttons are inoperable except the **MODE/SET** button. **MODE/SET** remains operational so the service person can perform the Manual Advanced Diagnostics, see below, to further isolate the problem.

#### Procedure for removing error code from display:

1. Unplug transformer from electrical outlet.
2. Correct problem.
3. Plug in transformer.
4. Wait 8 minutes. The error code will return if the problem was not corrected.

### MANUAL INITIATED ELECTRONIC DIAGNOSTICS

Use the following procedures to advance the water softener through the regeneration cycles to check operation.

Lift off the Salt Hole Cover, remove the top cover by unlocking the tabs in the back and rocking forward, to observe cam and switch operation during valve rotation.

1. Press and hold **MODE/SET** for 3 seconds until the Set low salt alarm display appears, next press the **MODE/SET** button two additional times until "000" shows in the display, then release, see Figure 15.
2. The 3 digits indicated water meter operation as follows: If you don't get a reading on the display, with faucet open, pull the sensor from the valve outlet port. Pass a small magnet back and forth in front of the sensor. You should get a reading in the display. If you get a reading, shut off water supply, unhook the in and out plumbing and check the turbine for binding.

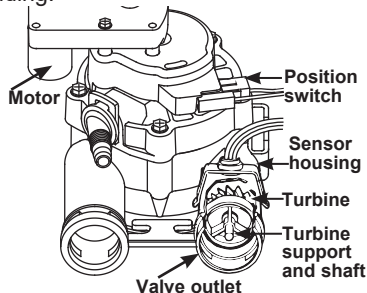

# Advanced troubleshooting for service

## MANUAL INITIATED ELECTRONIC DIAGNOSTICS (Cont.)

3. Symbols in the display indicate POSITION switch operation, see Figure 15

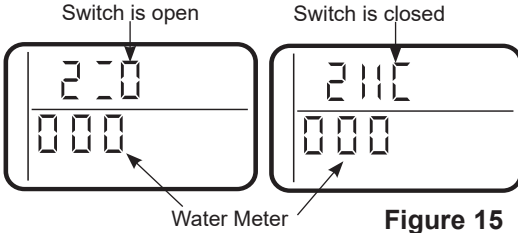

4. Use **RECHARGE** button to manually advance the valve into each cycle and check correct switch operation. **NOTE:** Be sure water is in contact with salt, and not separated by a salt bridge (see Breaking a Salt Bridge section).
5. While in this diagnostic screen, the following information is available and may be beneficial for various reasons. This information is retained by the computer from the first time electrical power is applied to the electronic controller.
- Press the ▲ UP button to display the number of days this electronic control has had electrical power applied.
  - Press the ▼ DOWN button to display the number of regenerations initiated by the electronic control since the code number was entered.

6. Press and hold the **MODE/SET** button until the mode code (F30 for GXSH30V) shows in the display. This code identifies the softener mode. If an incorrect model code is displayed, the softener will operate on incorrect configurations data.



7. To change the code number, press the ▲ UP or ▼ DOWN button until the correct code shows.
8. To return to the present time display, press the **MODE/SET** button.
9. Press the **MODE/SET** button to return to the present time display. If the code was changed, make all the timer setting. **NOTE:** If the control is left in a diagnostic display or a flashing display when setting times or hardness, present time automatically returns if a button is not pressed within four minutes.

# Advanced troubleshooting for service

---

## Service: Manually Advance Recharge Check

**NOTE:** The control display must show a steady time (not flashing).

1. Press the **RECHARGE** button and hold in for three seconds. **RECHARGE NOW** begins to flash as the water softening system enters the fill cycle of recharge. Remove the brinewell cover and, using a flashlight, observe fill water entering the brine tank. If water does not enter the tank, look for an obstructed nozzle, venturi, fill flow plug or brine tubing. See Care and Cleaning of the Water Softener System section.
2. After observing fill, press the **RECHARGE** button to move the water softening system into brining. A slow flow of water to the drain will begin. Verify brine draw from the brine tank by shining a flashlight into the brinewell and observing a noticeable drop in the liquid level over an extended period of time (15 to 20 minutes).

**NOTE:** Be sure a salt bridge is not preventing water from contacting salt. See Care and cleaning of the water softening system section.

If the water softening system does not draw brine, check:

- nozzle and/or venturi dirty or defective.
- defective nozzle and venturi seal.
- nozzle and venturi not seated properly on gasket.
- other inner valve defect (rotor seal, rotor and disc, wave washer, etc.).
- restricted drain (check drain fitting and hose).

**NOTE:** If water system pressure is low, an elevated drain hose may cause back pressure, stopping brine draw.

3. Again, press the **RECHARGE** button to move the water softening system into backwash. Look for a fast flow of water from the drain hose. A slow flow indicates a plugged top distributor, backwash flow plug or drain hose.
4. Press the **RECHARGE** button to move the water softening system into fast rinse. Again look for a fast drain flow. Allow the water softening system to rinse for a few minutes to flush out any brine that may remain in the resin tank from the brining cycle test.
5. To return the water softening system to service, press the **RECHARGE** button.

# Exploded View

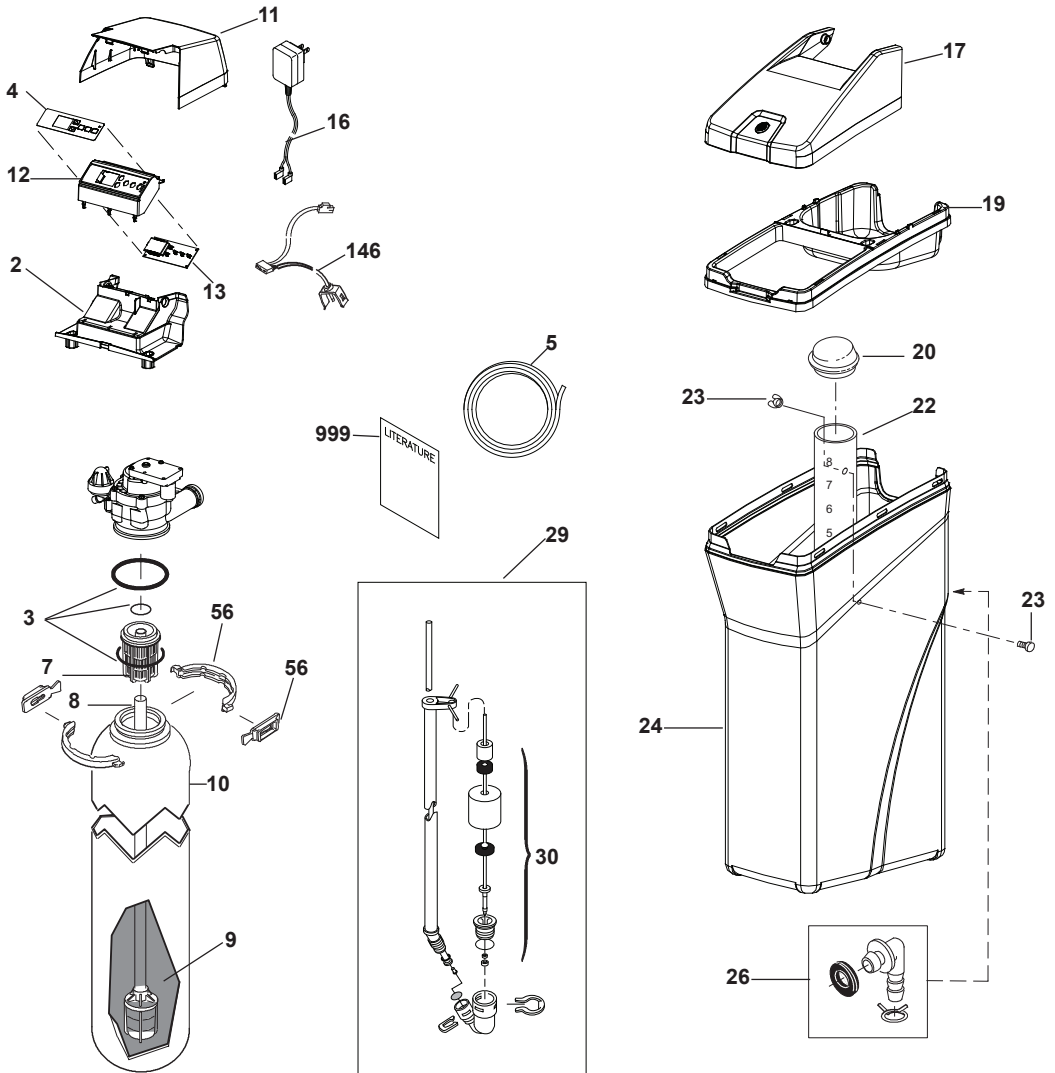

# Exploded View

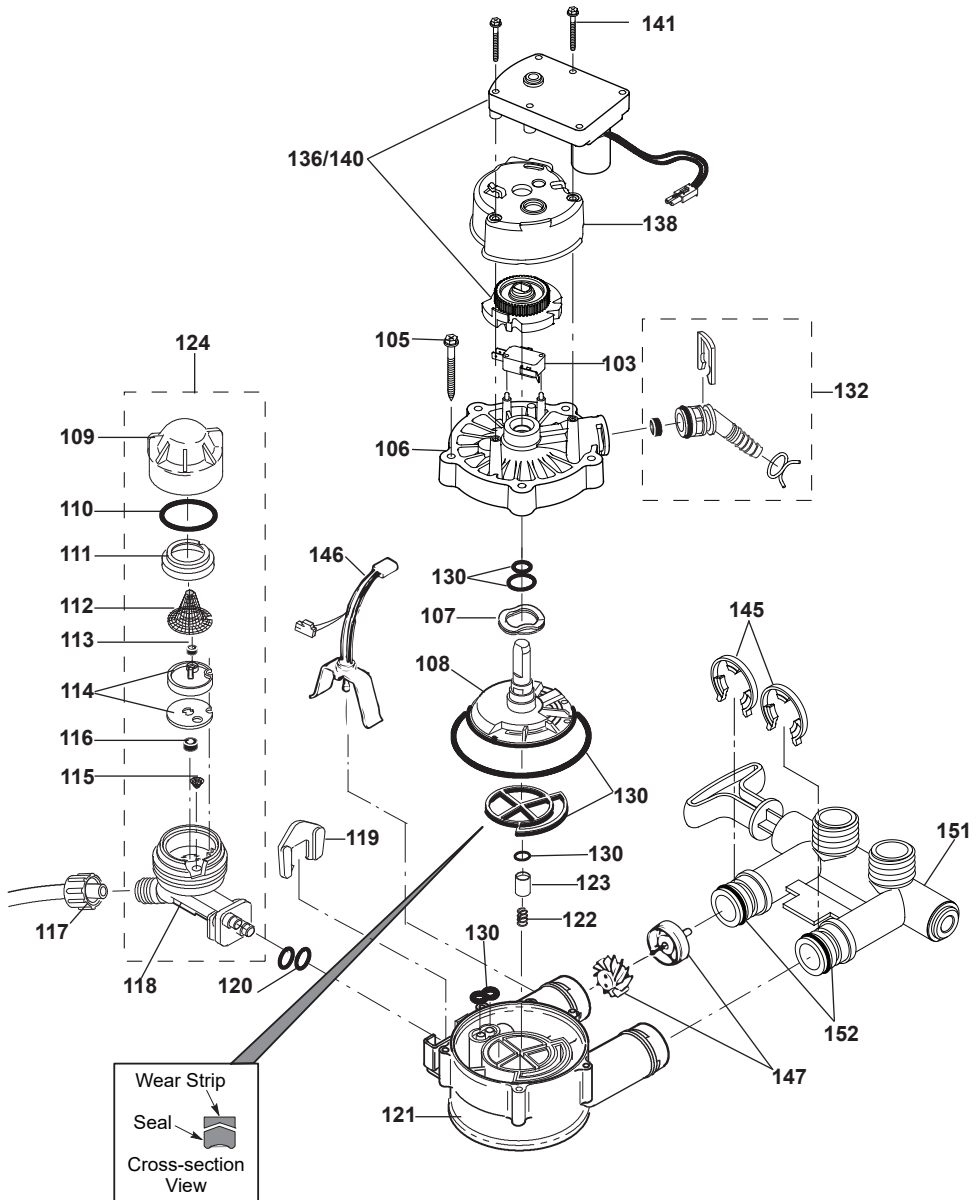



# Parts List

GXS F30V	REF. NO.	PART NO.	PART DESCRIPTION	(01)
	0002	WS31X10051	BACK COVER, ELECTRONICS	1
	0003	WS35X10001	O-RING SEAL KIT	1
	0004	WS34X10020	DECAL, FACEPLATE	1
	0005	WS07X10004	HOSE, DRAIN, 20 FT.	1
	0007	WS14X10002	DISTRIBUTOR, TOP	1
	0008	WS14X10005	DISTRIBUTOR, BOTTOM	1
	0009	WS01X10002	RESIN, 1 CU. FT.	1
	0010	WS32X10030	TANK, RESIN, 9 X 35	1
	0011	WS31X10052	COVER, TOP	1
	0012	WS34X10021	FACEPLATE	1
	0013	WS21X10053	CONTROL	1
	0016	WS26X10013	EXTERNAL POWER SUPPLY WITH POWER CORD	1
	0017	WS31X10053	COVER, SALT HOLE, WITH LABEL	1
	0019	WS33X10010	RIM	1
	0020	WS31X10024	COVER, BRINEWELL	1
	0022	WS34X10025	BRINEWELL	1
	0023	WS02X10088	SCREW KIT, BRINE TANK	1
	0024	WS32X10031	TANK, BRINE	1
	0026	WS22X10063	OVERFLOW ADAPTER KIT	1
	0029	WS15X10077	BRINE VALVE ASM.	1
	0030	WS35X10063	FLOAT, STEM & GUIDE	1
	0056	WS28X10078	TANK NECK CLAMP KIT	1
	0103	WS21X10003	SWITCH	1
	0105	WS02X10014	SCREW, #10 - 14 x 2"	5
	0106	WS31X20060	COVER, VALVE	1
	0107	WS03X10010	WASHER WAVE	1
	0108	WS26X10002	ROTOR & DISC ASM.	1
	0109	WS19X10010	CAP	1
	0110	WS03X10011	SEAL, O-RING 1.125 X 1.37	1
	0111	WS19X10005	SUPPORT SCREEN	1
	0112	WS03X10013	SCREEN	1
	0113	WS22X10036	FLOW PLUG, .15 GPM	1
	0114	WS08X10008	GASKET, NOZZLE/VENT	1
	0115	WS03X10073	SCREEN CONE	1
	0116	WS22X10021	PLUG, FILL FLOW, .30 GPM	1
	0117	WS03X10017	NUT FERRULE	1
	0118	WS15X10034	NOZZLE/VENTURI BODY	1
	0119	WS03X10018	RETAINER	1
	0120	WS03X10019	SEAL, O-RING, 1/4" X 3/8"	2
	0121	WS15X10010	BODY, VALVE	1
	0122	WS03X10020	SPRING	1
	0123	WS22X10022	PLUG, DRAIN SEAL	1
	0124	WS15X10046	NOZZLE/VENTURI ASM.	1
	0130	WS35X10005	SEAL KIT	1
	0132	WS22X10064	DRAIN HOSE ADAPTER KIT	1
	0136/140	WS26X21822	MOTOR, CAM & GEAR KIT, 3/4"	1
	0138	WS26X20061	MOTOR MOUNT	1
	0141	WS02X20063	SCREW, #6-19 x 1-3/8"	2
	0143	WS60X10013	ADAPTER—NPT THREADED—STD VALVE	2
	0145	WS60X10004	CLIP	4
	0146	WS28X10017	HARNES WIRE, SENSOR ASSY	1
	0147	WS19X10006	TURBINE & SUPPORT ASM.*	1
	0151	WS15X21823	BYPASS VALVE ASM.*	1
	0152	WS03X10025	SEAL, O-RING	4
	0998	WS35X10064	INSTALLATION KIT	1
	0999	49-50282-8	OWNER'S MANUAL	1

\* Includes 2 each of REF. NO. 152 (O-RING)