



PORTABLE AUTOMATIC ICE MAKER



Model: MIM-18(A~Z)

INSTRUCTION MANUAL

It is important that you read these instructions before using your portable ice maker. It is strongly recommend that you keep them in a safe place for future reference.

TABLE OF CONTENTS

<i>IMPORTANT SAFEGUARDS</i>	2-3
<i>IMPORTANT SAFETY INSTRUCTIONS</i>	3
<i>PARTS IDENTIFICATION</i>	4-5
<i>OPERATING PROCEDURES & MAINTENANCE</i>	
UNPACKING YOUR ICE MAKER.....	5
CONNECTING YOUR ICE MAKER.....	6
HOW TO CLEAN.....	6
CARE AND MAINTENANCE.....	7
<i>USING YOUR ICE MAKER</i>	7
<i>TROUBLESHOOTING</i>	8-9
<i>MORE TIPS AND GUIDES</i>	10
<i>WARRANTY INFORMATION</i>	11
<i>RETURN INSTRUCTIONS</i>	12

IMPORTANT SAFEGUARDS

When using electrical appliances, basic safety precautions should be followed to reduce the risk of fire, electric shock, and injury to persons or property. Read all instructions before using any appliance.

- Do not operate this or any other appliance with a damaged cord.
- Connect to properly polarized outlets only. No other appliance should be plugged into the same outlet. Be sure that the plug is fully inserted into the receptacle.
- Do not run cord over carpeting or other heat insulators. Do not cover the cord. Keep cord away from traffic areas, and do not submerge in water.
- We do not recommend the use of an extension cord, as it may overheat and become a risk of fire. If you must use an extension cord, use No.14 AWG minimum size and rated no less than 1875 watts.
- Unplug the ice maker before cleaning or making repairs.
- Exercise caution and use reasonable supervision when appliance is used near children.
- Do not clean your ice maker with flammable fluids. The fumes can create a fire hazard or explosion.
- Do not tip over.
- If the ice maker is brought indoors from outdoors during the wintertime, give it a few hours to warm up to room temperature before plugging it in.
- It is strongly recommended that any servicing be done by a qualified individual.
- Do not leave this appliance in places of either extreme cold or warm temperatures.
- Do not place the appliance near any sources of heat or open flame.
- Do not place heavy items on top of this appliance.
- Never install or place the ice maker where there is a lot of moisture or where water can splash on it.
- Use extreme caution when appliance is used near children
- Do not let children operate this device.
- Do not operate the appliance after either the side or back panels have been removed.
- Do not operate any appliance with a damaged cord or plug or after the appliance malfunctions or has been damaged in any manner. Return the appliance to the nearest authorized service facility for examination, repair or adjustment.
- Remove all packaging plastics and other materials from the unit before operating.
- Wash all removable accessories before using for the first time.
- To protect against electrical shock, do not immerse cord, plug or appliance itself in water or other liquids.
- The use of accessory attachments not recommended by the appliance manufacturer may cause injuries.

IMPORTANT SAFEGUARDS (CONT.)

- Always attach plug to appliance first, then plug cord into wall outlet. To disconnect, turn all controls to the OFF position, grasp plug body and remove from the electrical outlet. Do not pull by the cord.
- Do not store any materials other than the manufacturer's recommended accessories in this appliance when it is not in use.
- Do not use the appliance for other than its intended use.

SAVE THESE INSTRUCTIONS
THIS PRODUCT IS FOR HOUSEHOLD USE ONLY!



WARNING

DO NOT TOUCH THE EVAPORATOR WHILE THE UNIT IS IN USE OR DURING THE ICE MAKING PROCESS. IT MAY CAUSE SEVERE BURNING.

DO NOT MODIFY THE POWER CORD UNDER ANY CIRCUMSTANCES TO ALLOW THE UNIT TO BE PLUGGED INTO A NON-GROUNDED OUTLET.

THE ICE MAKER SHOULD NOT BE INSTALLED NEAR ANY HEAT SOURCE OR WHERE IT WILL COME IN DIRECT CONTACT WITH THE SUNLIGHT.

PARTS IDENTIFICATION

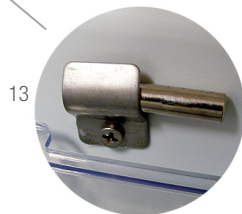
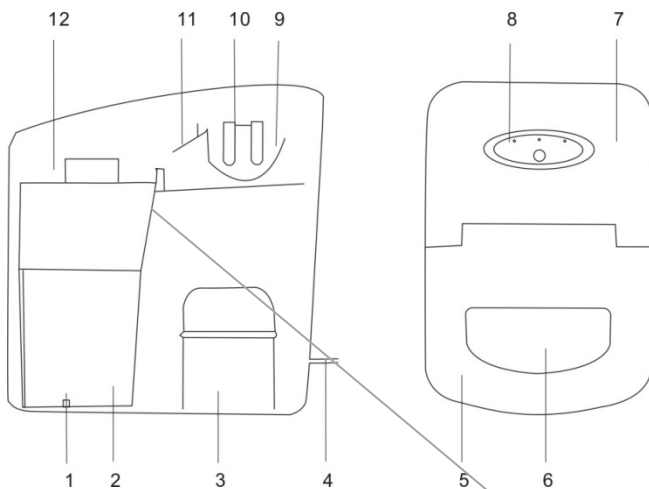
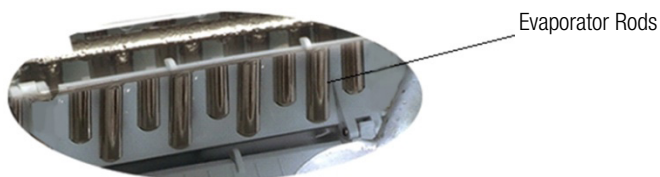

1. Silicon Water Drain Stopper - For draining water from the water reservoir.
2. Water Reservoir - holds up to 1.7L of water.
3. Compressor
4. Power Cord
5. Top Lid
6. Viewing Window
7. Back Top Cover
8. Control Panel - Easy to use, visible functions and 1-touch display setting.
9. Water Tray
10. Evaporator Rods
11. Ice Case Panel - The panel that pushes already formed ice into the Ice Basket.
12. Ice Basket - Sits above the Water Reservoir and holds already formed ice.
13. Ice Sensor - Ice Sensor determines when the Ice Basket is full.

PARTS IDENTIFICATION (CONT.)

Control Panel Operation

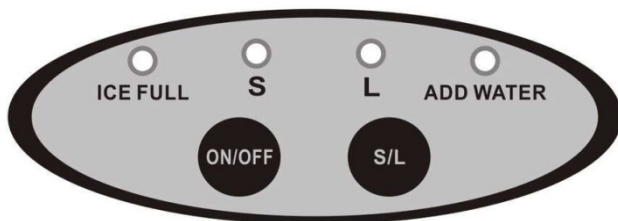

SIZE S (SMALL) or L (LARGE): Press to select the size of ice to make. Choose between size Small and Large.

ON/OFF: Press to power unit on or off.

ADD WATER: This light will turn on along with a beep indicator when the water level is too low. You will need to add water to the Water Reservoir and press the „Power“ button twice to restart the ice maker.

ICE FULL: This light will turn on with a beep indicator when the ice has reached the maximum capacity of the storage cabinet. Press the „Power“ button twice to restart the ice maker after some of the ice has been removed from the Ice Bucket.

OPERATING PROCEDURES AND MAINTENANCE

UNPACKING YOUR ICE MAKER

1. Remove all exterior and interior packaging. Check that the ice basket and ice scoop are included. If any part or accessory is missing, please contact our customer service department. (Contact information on p. 11)
2. Clean the interior with lukewarm water and a soft cloth. Remove the ice basket and wash it in warm water.
3. Wipe the evaporator rods clean using a water/vinegar solution.
4. Find a location for your ice maker that is protected from direct sunlight and other sources of heat (i.e. stove, furnace, radiator, etc...). Place the ice maker on a level surface and make sure that there is at least 5 inches of space between the back and sides of your ice maker and the wall.
5. **Allow the refrigerant fluid to settle for several hours before plugging in the unit.**
6. The appliance must be positioned so that the plug is accessible.

OPERATING PROCEDURES AND MAINTENANCE (CONT.)

CONNECTING YOUR ICE MAKER



DANGER

Improper use of the grounded plug can increase the risk of an electrical shock. If the power cord is damaged, please call our customer service department. (Contact information on p.11)

1. This unit should be properly grounded for your safety. The power cord of this appliance is equipped with a three-prong plug which plugs into a standard three prong wall outlet to minimize the possibility of electric shock.
2. Plug your appliance into its own, properly installed, grounded wall outlet. **Do not under any circumstances cut or remove the third (ground) prong from the power cord.** Any questions concerning power and/or grounding should be directed toward a certified electrician.
3. This appliance requires a standard 120 volt, 60Hz electrical outlet with three-prong ground.

The ice maker is not designed to be installed in an outside area such as a garage or a porch. Ambient temperatures of below 65°F or above 90°F will hinder the performance of the appliance.

*** BEFORE USING YOUR ICE MAKER, IT IS STRONGLY RECOMMENDED TO CLEAN IT THOROUGHLY.**

HOW TO CLEAN

1. Remove the ice basket.
2. Unplug the Drain Stopper to drain out all water inside.
3. Clean the interior with diluted detergent, warm water and a soft cloth.
4. Clean the exterior of the ice maker regularly with a mild detergent solution and warm water.
5. Dry the interior and exterior with a soft cloth.

Note: Make sure all parts are thoroughly dry before reassembling your unit. Insert the Drain Stopper back into the Ice Maker.

6. When the machine is not in use, unplug the Drain Stopper to drain water completely from water reservoir.

MOLD FORMATION CAN OCCUR IF MOISTURE GETS TRAPPED INSIDE OF THE UNIT. DRAIN ALL WATER FROM THE UNIT AFTER EVERY USE AND DRY THOROUGHLY BEFORE STORING.

OPERATING PROCEDURES AND MAINTENANCE (CONT.)

CARE AND MAINTENANCE

- The ice maker should be cleaned on a regular basis. (See the “HOW TO CLEAN” section on p.6)
- It is necessary to have an adequate ventilation space around the ice maker in order to sustain proper performance, dissipation of heat, maintain efficiency, and low power consumption. Clearance of a minimum of 5 inches should be maintained at the rear and sides of the unit, and 8 inches at the top of the unit.
- To attain proper performance, be sure to plug the appliance into a properly grounded 120/60Hz outlet.
- To avoid heat damage to the power cord, please ensure that it does not come in proximity or in direct contact with the compressor of the ice maker.
- Please avoid installing the ice maker in a location where the appliance will come in contact with water or moisture, to minimize the buildup of rust on the metal parts.
- **ONLY FRESH, CLEAN WATER CAN BE USED ON THIS APPLIANCE. THE USE OF JUICES, MILK, SODA, AND THE LIKE MAY DAMAGE THE UNIT.**

USING YOUR ICE MAKER

1. Clean your ice maker before using. Make sure the unit is off and unplugged from the outlet.
2. Open the cover and pour water into the tank.
NOTE: Make sure the water level in the water reservoir is not over the Ice Basket.
NOTE: Use distilled water for best results.
3. Close the lid.
4. Plug the unit into the electrical outlet. When the Ice Maker is first plugged in, it will default to the Small (S) ice setting which will be flashing.
5. Select the ice size you wish by pressing the S/L button to cycle between Small or Large ice.
6. Once the size has been selected, press ON/OFF to begin the ice making cycle. The indicator light for the size button will become solid.
NOTE: For the first three cycles, the ice may be small and irregular in size.
7. While the icemaker is on, regularly check the “Add Water” indicator. If the water pump can’t inject water, the ice maker will stop automatically and the “Add Water” indicator will be on. Turn the unit off using the “ON/OFF” button, then fill it with water right up to the bottom of the Ice Basket. **Allow 3 minutes for the refrigerant to settle.** After the refrigerant has settled, press the “ON/OFF” button again to restart the ice making cycle.
NOTE: If no water is pumped up to the water tray over two cycles but there is enough water in the water tank, please unplug the silicon stopper and let several drops of water run out. Restart the unit.
8. When the ice basket is full the “ICE FULL” indicator light will turn on. At this point, you can remove some of the ice with the scoop or you can allow the ice to remain in the Ice Maker.
9. Press “ON/OFF” button to stop the machine.
- Please note: This unit is not a freezer, it will not keep the Ice frozen permanently. The ice will eventually melt and as it melts, the internal temperature of the unit will rise and the Ice Maker will begin making ice once again. You have the option of removing the ice as it is formed and bagging it to store inside your freezer.

TROUBLESHOOTING

PROBLEM	POSSIBLE CAUSE	SOLUTION
Indicator lights are on but display is not on.	Blown fuse/ No power.	Replace fuse/ Turn power on.
“Ice Full” indicator is on.	Ice basket is full.	Remove ice from ice basket.
The compressor works abnormally with a buzzing noise	The voltage is lower than recommended.	Stop the ice maker and do not restart until the voltage is normal.
“Add Water” indicator light is on.	Water is low.	Press the OFF button, fill with water, wait for 3 minutes and press ON to restart. When the water has reached the fill line the ice maker will restart automatically.
	The pump is full of air.	Unplug the silicon stopper and let several drops of water run out.
The ice made is too large and cubes are sticking together.	Ice from previous cycles were left in the water tray.	Stop the unit right away. Restart the unit after the ice in water tray melts down.
	The evaporator rods are too low.	Shift the evaporator rods up a little.
	Water temperature in inner tank is too low.	Change the water in the reservoir. Use water between 45°F-80°F.
“Add Water” & “Ice Full” indicators both light up.	Water tray/Ice Case Panel are blocked by ice cubes.	Clear the ice cubes under the ice case panel, pull out the power plug from wall outlet and then plug back in. Press the “ON/OFF” button, allow a few minutes for the machine to restart automatically.

Machine keeps running but the water is warmer than the normal temperature.	The magnetic valve is broken.	Replace the magnetic valve.
Ice making cycle is normal but no ice is made.	Ambient temperature or water temperature in inner tank is too high.	Please operate the ice maker below ambient temperature of 90°F and use cold water.
	Refrigerant liquid leakage.	Consult a qualified technician.
	Pipe in the cooling system is blocked.	Consult a qualified technician.
Ice Maker is leaking water	The drain stopper may be not be inserted properly.	Check the drain stopper.
The ice cubes are melting.	<p>Location of appliance may cause temperature changes.</p> <p>Also constant opening and shutting of the lid may also cause variable temperature fluctuations.</p> <p>Leaving ice in the appliance for an extended period of time may also result in the appliance recycling the ice by melting it down and making a new batch.</p>	<p>Make sure the appliance is always placed in a temperature regulated area.</p> <p>Avoid leaving the lid open.</p> <p>Transfer ready-made ice to another container and store in a cooler or freezer to avoid recycling.</p>
There is not enough ice cubes in the ice basket, but the indicator of "ice full" is on.	<p>The room temperature may be too low.</p> <p>The ice cubes being formed may be touching the sensor occasionally when the ice case panel pushes the ice cubes into the ice basket.</p>	<p>Make sure the unit is in an area where the temperature is above 65°F regulated.</p> <p>Remove the ice cubes; wait for a few minutes to let the unit restart again.</p>
Humming or knocking sound heard from the back side of the unit.	Sound is normal and occurs as water is being pumped from the water tank.	Normal

MORE SPECIAL TIPS AND GUIDES

- **Leaking Water:**
 - Rubber Drain Stopper may be missing or not inserted properly. If missing, please contact customer service for a replacement rubber insert.
 - Check if unit still leaks water when power is unplugged. If unit does not leak water when power is unplugged then the water is leaking from the water pump. Please contact customer service for a replacement water pump.
- **Unit is not producing ice even though there is water inside the main tank:**
 - Make sure the main tank has been filled all the way up to the water level line which is right beneath the basket.
 - Check and make sure Ice Case Panel is not stuck or loose. If panel looks like it is at an odd angle or struggling to move back and forth please contact customer service for a replacement Ice Panel.
 - Check to see if red 'Add Water' light is on. If so and water tank is full, please see troubleshooting section regarding this problem.
- **Red 'Add Water' light is on when main water tank is full:**
 - First, make sure main tank has been filled all the way up to the water level line which is right beneath the basket.
 - If red light comes on immediately after pushing power and no water is drawn up to the ice making compartment (located by evaporator rods), then water pump may be stuck and is pumping only air. (You should be able to hear the water being drawn up – it will sound like a faucet running.)
 - Please contact customer service and they can walk you through the procedure of troubleshooting the water pump.
- **Ice-making process is extremely slow:**
 - When the machine is brand new, it may sometimes take a few hours for the machine to adjust and get used to producing ice at a faster rate and producing larger cubes of ice. This is considered normal.
 - Unit can start off slow and may take between 30 minutes up to 2 hours of continuous use before ice production cycles become shorter. After approximately 2-3 hours of continuous use, you should see each batch (9 ice cubes) being produced between 7-9 minutes.
- **Unit has unusual smell:**
 - The Ice Maker has excess manufacturer lubricants that are being blown off by the motor fan located in the back of the unit. Please contact customer service if the problem persists.
- **Ice has unusual smell or taste:**
 - Add one to two cups of lemon juice or vinegar to full tank of water and completely cycle through. This may take a few hours. If problem persists, repeat same procedure call customer service.

**For all other questions or issues please contact our customer service department.
(Contact information found on p.11)**

**LIMITED WARRANTY* ONE (1) YEAR
WARRANTY IS ONLY VALID WITH A DATED PROOF OF PURCHASE**

1. Your small kitchen appliance is built with precision, inspected and tested before leaving our factory.
2. It is warranted, to the original purchaser to be free from any manufacturing defects under normal use and conditions for one (1) year, cord excluded. This Warranty applies only to the original purchaser of this product.
3. If you need to exchange the unit, please return it in its original carton, with a sales receipt, to the store where you purchased it. If you are past the stores allowed return policy period, please see the enclosed Warranty.
4. If you use your appliance for household use and according to instructions, it should give you years of satisfactory service.
5. During the one-year warranty period, a product with a defect will be either repaired or replaced with a new or reconditioned comparable model (at our option) when the product is returned to our Service Center. (See the "Returns" section below).
6. The repaired or replacement product will be in warranty for the remaining balance of the one-year warranty period and an additional one-month period.
7. **This limited warranty covers appliances purchased and used within the 50 contiguous states plus the District of Columbia and does NOT cover:**

- Damages caused by unreasonable use, neglect, normal wear and tear, commercial use, improper assembly or installation of product.
- Damages caused in shipping.
- Damages caused by replacement or resetting of house fuses or circuit breakers.
- Defects other than manufacturing defects.
- Breakage caused by misuse, abuse, accident, alteration, lack of proper care and maintenance, or incorrect current or voltage.
- Lost or missing parts of the product. Parts will need to be purchased separately.
- Damages of parts that are not electrical; for example: cracked or broken plastic or glass.
- Damage from service or repair by unauthorized personnel.
- Extended warranties purchased via a separate company or reseller.
- Consumer's remorse is not an acceptable reason to return a product to our Service Center.

*One Year Limited Warranty valid only in the **50 contiguous states plus the District of Columbia, excluding** Puerto Rico and the Virgin Islands.

This warranty is effective only if the product is purchased and operated in the USA; product usage which is in violation of the written instructions provided with the unit will void this warranty. For international warranty, please contact the local distributor.

**Any instruction or policy included in this manual may be subject to change at any time.

MAXI-MATIC, USA

18401 E. Arenth Ave. City of Industry, CA 91748

Customer Service Dept: (800) 365-6133 Ext: 120/107/105 MON-FRI 8:30am-5pm PST

Website: www.maxi-matic.com email: info@maxi-matic.com

RETURN INSTRUCTIONS

RETURNS:

- A. Any return of defective merchandise to the manufacturer must be processed accordingly by first contacting customer service (contact information shown below) to obtain an RA # (Return Authorization Number). We will not accept any returns of merchandise without an applicable RA #.
- B. **IMPORTANT RETURN INSTRUCTIONS.** Your Warranty depends on your following these instructions if you are returning the unit to Maxi-Matic USA:
 1. Carefully pack the item in its original carton or other suitable box to avoid damage in shipping.
 2. Before packing your unit for return, be sure to enclose:
 - a) Your name, full address with zip code, daytime telephone number, and RA#,
 - b) A dated sales receipt or PROOF OF PURCHASE,
 - c) The model number of the unit and the problem you are having (Enclose in an envelope and tape directly to the unit before the box is sealed), and
 - d) Any parts or accessories related to the problem.
 3. Maxi-Matic USA recommends you ship the package U.P.S ground service for tracking purposes. We cannot assume responsibility for lost or damaged products returned to us during incoming shipment. For your protection, always carefully package the product for shipment and insure it with the carrier. C.O.D shipments cannot be accepted.
 4. **All return shipping charges must be prepaid by you.**
 5. Mark the outside of your package:
MAXI-MATIC USA

18401 E. ARENTH AVE.

CITY OF INDUSTRY, CA 91748
6. Once your return has been received by our warehouse, Maxi-Matic USA will repair or replace the product if it is defective in material or workmanship, subject to the conditions in paragraph B.
7. **Maxi-Matic will pay the shipping charges to ship the repaired or replacement product back to you.**