

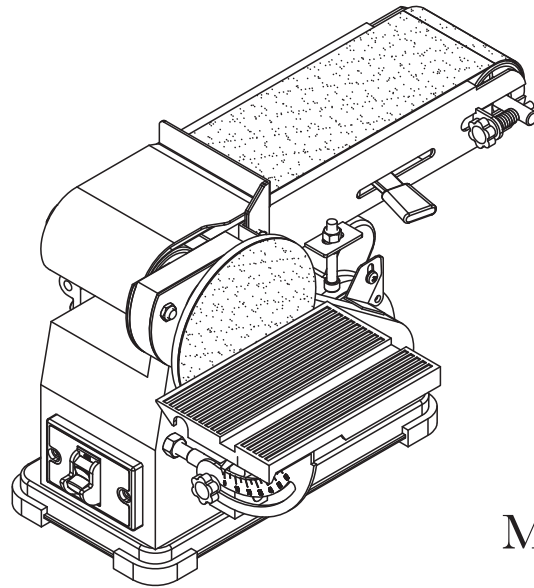

BELT DISC SANDER WITH STEEL BASE



Model # 6500, 6500T
bit.ly/wenvideo

IMPORTANT:

Your new tool has been engineered and manufactured to WEN's highest standards for dependability, ease of operation, and operator safety. When properly cared for, this product will supply you years of rugged, trouble-free performance. Pay close attention to the rules for safe operation, warnings, and cautions. If you use your tool properly and for its intended purpose, you will enjoy years of safe, reliable service.

NEED HELP? CONTACT US!

Have product questions? Need technical support?
Please feel free to contact us at:

 **800-232-1195** (M-F 8AM-5PM CST)

 techsupport@wenproducts.com

 **WENPRODUCTS.COM**

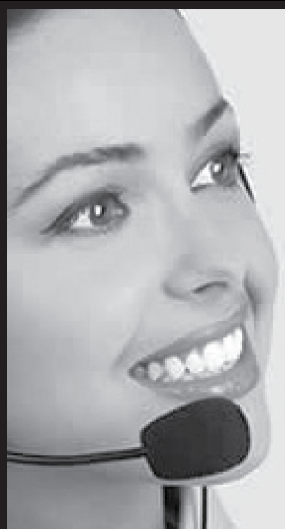

TABLE OF CONTENTS

Technical Data	2
General Safety Rules	3
Specific Safety Rules For Belt/Disc Sander	4
Electrical Information	5
Know Your Belt/Disc Sander	7
Assembly and Adjustments	8
Operation	10
Maintenance	11
Troubleshooting	12
Exploded View and Parts List	13
Warranty	15

TECHNICAL DATA

Model Number:	6500, 6500T
Motor:	120 V, 60 Hz, 3.2 A
Speed:	1150 FPM
Disc Diameter:	6"
Belt Size:	4" x 36"
Belt Bed Tilt:	0 to 90°
Net Weight:	32.2 lb
Product Dimensions:	17 x 13 x 11 inches

GENERAL SAFETY RULES

Safety is a combination of common sense, staying alert and knowing how your item works. **SAVE THESE SAFETY INSTRUCTIONS.**



WARNING: To avoid mistakes and serious injury, do not plug in your tool until the following steps have been read and understood.

1. **READ** and become familiar with this entire instruction manual. **LEARN** the tool's applications, limitations, and possible hazards.
2. **AVOID DANGEROUS CONDITIONS.** Do not use power tools in wet or damp areas or expose them to rain. Keep work areas well lit.
3. **DO NOT** use power tools in the presence of flammable liquids or gases.
4. **ALWAYS** keep your work area clean, uncluttered, and well lit. **DO NOT** work on floor surfaces that are slippery with sawdust or wax.
5. **KEEP BYSTANDERS AT A SAFE DISTANCE** from the work area, especially when the tool is operating. **NEVER** allow children or pets near the tool.
6. **DO NOT FORCE THE TOOL** to do a job for which it was not designed.
7. **DRESS FOR SAFETY.** Do not wear loose clothing, gloves, neckties, or jewelry (rings, watches, etc.) when operating the tool. Inappropriate clothing and items can get caught in moving parts and draw you in. **ALWAYS** wear non-slip footwear and tie back long hair.
8. **WEAR A FACE MASK OR DUST MASK** to fight the dust produced by operations.



WARNING: Dust generated from certain materials can be hazardous to your health. Always operate the tool in a well-ventilated area and provide for proper dust removal. Use dust collection systems whenever possible.

9. **ALWAYS** remove the power cord plug from the electrical outlet when making adjustments, changing parts, cleaning, or working on the tool.
10. **KEEP GUARDS IN PLACE AND IN WORKING ORDER.**
11. **AVOID ACCIDENTAL START-UPS.** Make sure the power switch is in the **OFF** position before plugging in the power cord.
12. **REMOVE ADJUSTMENT TOOLS.** Always make sure all adjustment tools are removed from the tool before turning it on.
13. **NEVER LEAVE A RUNNING TOOL UNATTENDED.** Turn the power switch to **OFF**. Do not leave the tool until it has come to a complete stop.
14. **NEVER STAND ON A TOOL.** Serious injury could result if the tool tips or is accidentally hit. **DO NOT** store anything above or near the tool.

GENERAL SAFETY RULES

15. **DO NOT OVERREACH.** Keep proper footing and balance at all times. Wear oil-resistant rubber-soled footwear. Keep the floor clear of oil, scrap, and other debris.
16. **MAINTAIN TOOLS PROPERLY.** ALWAYS keep tools clean and in good working order. Follow instructions for lubricating and changing accessories.
17. **CHECK FOR DAMAGED PARTS.** Check for alignment of moving parts, jamming, breakage, improper mounting, or any other conditions that may affect the tool's operation. Any part that is damaged should be properly repaired or replaced before use.
18. **MAKE THE WORKSHOP CHILDPROOF.** Use padlocks and master switches and ALWAYS remove starter keys.
19. **DO NOT** operate the tool if you are under the influence of drugs, alcohol, or medication that may affect your ability to properly use the tool.
20. **USE SAFETY GOGGLES AT ALL TIMES** that comply with ANSI Z87.1. Normal safety glasses only have impact resistant lenses and are not designed for safety. Wear a face or dust mask when working in a dusty environment. Use ear protection such as plugs or muffs during extended periods of operation.

SPECIFIC RULES FOR THE BELT SANDER



WARNING: Do not operate this tool until it is completely assembled and installed according to the instructions.

1. This sander is designed to sand wood or wood-like products only. Sanding or grinding other materials could result in fire, injury, or damage to the workpiece.
2. Use the sander on horizontal surfaces only. Operating the sander when mounted on non-horizontal surfaces may result in motor damage or injury.
3. Make sure the sanding belt is installed in the correct direction. See directional arrow on back of belt.
4. Always have the tracking adjusted properly so the belt does not run off the pulleys.
5. Do not use sanding belts or discs that are damaged, torn, or loose. Use only correct size sanding belt and disc.
6. Always hold the workpiece firmly when sanding. Keep hands away from sanding belt or disc. Sand only one workpiece at a time.
7. Always hold the workpiece firmly on the table when using the disc sander and when using the belt sander.
8. Always sand on the downward side of the sanding disc when using the disc sander. Sanding on the upward side of the disc can cause the workpiece to fly out of position, resulting in injury.
9. Always maintain a minimum clearance of 1/16 inch (1.6 mm) or less between the table or backstop and the sanding belt or disc.

SPECIFIC RULES FOR THE BELT SANDER

10. Do not sand pieces of material that are too small to be safely supported.
11. When sanding a large workpiece, provide additional table height support.
12. Do not sand with the workpiece unsupported. Support the workpiece with the backstop or table. The only exception is curved work performed on the outer sanding drum.
13. Always remove scrap pieces and other objects from the table, backstop, or belt before turning the sander ON.
14. Never perform layout, assembly or set-up work on the table while the sander is operating.
15. Never use solvents to clean plastic parts. Solvents could dissolve or otherwise damage the material. Use only a soft damp cloth to clean plastic parts.
16. Should any component of your sander be missing/damaged or fail in any way, shut off switch and remove plug from power supply outlet. Replace the missing, damaged, or failed parts before resuming operation.
17. Never pull the power cord out of the receptacle. Keep cords away from heat, oil, and sharp edges.
18. Have an electrician replace or repair damaged or worn cords immediately.

ELECTRICAL INFORMATION

GROUNDING INSTRUCTIONS

IN THE EVENT OF A MALFUNCTION OR BREAKDOWN, grounding provides the path of least resistance for an electric current and reduces the risk of electric shock. This tool is equipped with an electric cord that has an equipment grounding conductor and a grounding plug. The plug **MUST** be plugged into a matching outlet that is properly installed and grounded in accordance with **ALL** local codes and ordinances.

DO NOT MODIFY THE PLUG PROVIDED. If it will not fit the outlet, have the proper outlet installed by a licensed electrician.

IMPROPER CONNECTION of the equipment grounding conductor can result in electric shock. The conductor with the green insulation (with or without yellow stripes) is the equipment grounding conductor. If repair or replacement of the electric cord or plug is necessary, **DO NOT** connect the equipment grounding conductor to a live terminal.

CHECK with a licensed electrician or service personnel if you do not completely understand the grounding instructions or whether the tool is properly grounded.

USE ONLY THREE-WIRE EXTENSION CORDS that have three-pronged plugs and outlets that accept the tool's plug as shown in Fig. A. Repair or replace a damaged or worn cord immediately.

ELECTRICAL INFORMATION

CAUTION: In all cases, make certain the outlet in question is properly grounded. If you are not sure, have a licensed electrician check the outlet.



WARNING: This tool is for indoor use only. Do not expose to rain or use in damp locations.
Guidelines for using extension cords

Make sure your extension cord is in good condition. When using an extension cord, be sure to use one heavy enough to carry the current your product will draw. An undersized cord will cause a drop in line voltage resulting in loss of power and overheating. The table below shows the correct size to be used according to cord length and nameplate ampere rating. When in doubt, use a heavier cord. The smaller the gauge number, the heavier the cord.

Make sure your extension cord is properly wired and in good condition. Always replace a damaged extension cord or have it repaired by a qualified person before using it.

Protect your extension cords from sharp objects, excessive heat and damp/wet areas.

Use a separate electrical circuit for your tools. This circuit must not be less than a #12 wire and should be protected with a 15 A time-delayed fuse. Before connecting the motor to the power line, make sure the switch is in the OFF position and the electric current is rated the same as the current stamped on the motor nameplate. Running at a lower voltage will damage the motor.

WARNING: This tool must be grounded while in use to protect the operator from electric shock.

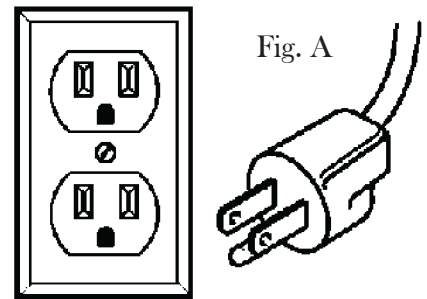

AMPERAGE	REQUIRED GAUGE FOR EXTENSION CORDS			
	25 ft.	50 ft.	100 ft.	150 ft.
3.2 A	18 gauge	16 gauge	16 gauge	14 gauge

KNOW YOUR BELT/DISC SANDER

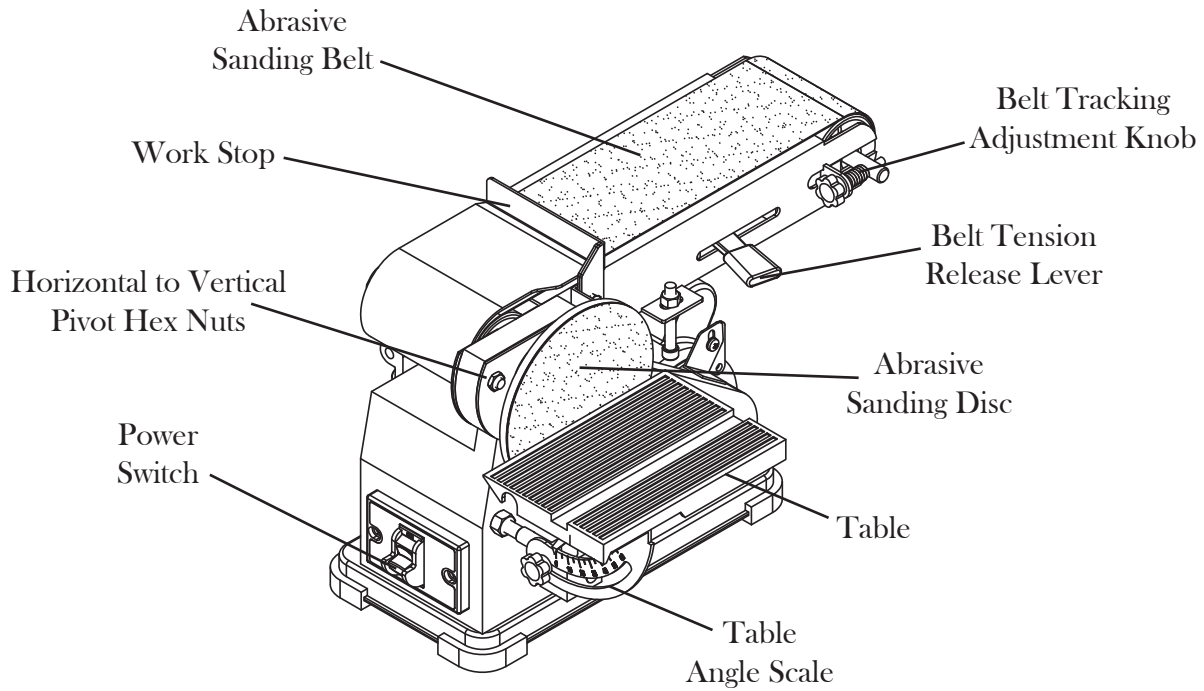

UNPACKING



WARNING: To avoid injury from accidental startups, turn switch OFF and remove the plug from the power source outlet before making any adjustments.

Carefully unpack the belt/disc sander and all its parts, and compare against the list below. Do not discard the carton or any packaging until the belt/disc sander is completely assembled.

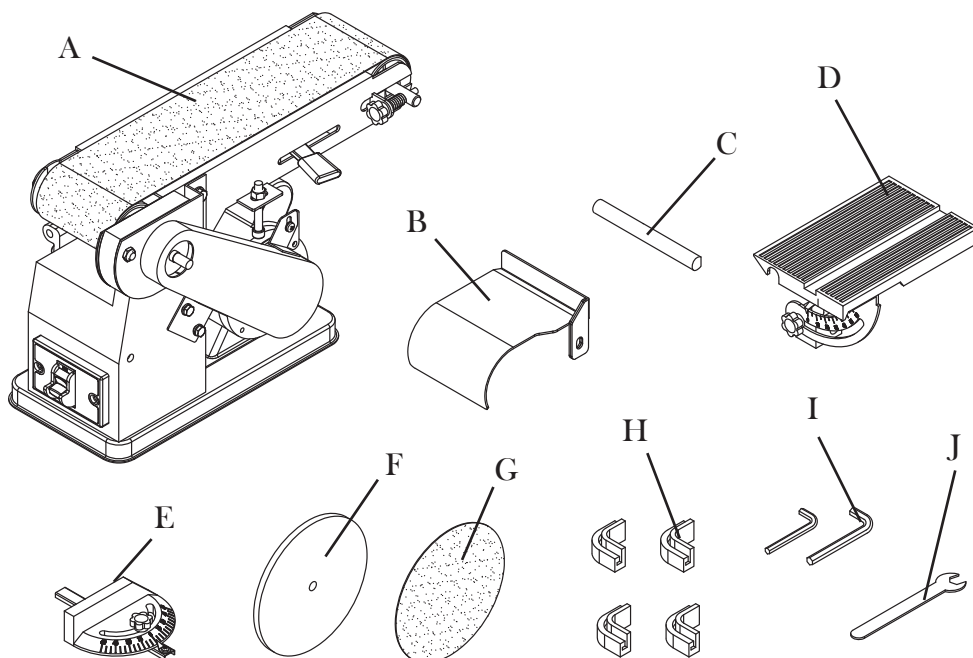

UNPACKING

- A - Belt Sander
- B - Work Stop
- C - Support Rod
- D - Table Assembly
- E - Miter Gauge
- F - Aluminum Disc
- G - Abrasive Sanding Disc
- H - Foot (4)
- I - Hex Wrench (2)
- J - Spanner (1)

ASSEMBLY AND ADJUSTMENTS

FEET INSTALLATION (Fig. B)

1. Carefully set the belt sander on its side.
2. Find the four rubber feet (Fig. B - 1) in the parts bag.
3. Press-fit each rubber foot over the lip of the corners around the base of the machine.

MOUNTING THE ALUMINUM DISC (Fig. C)

1. Place the belt sander so that it is sitting on its feet.
2. Loosen the disc's set screw (Fig. C - 2) with a hex wrench (Fig. C - 1).
3. Slide the disc all the way onto the drive shaft so that the set screw faces the shaft's flat surface.
4. Securely tighten the set screw.

MOUNT THE DISC SANDER TABLE

1. Install the support rod (Fig. D - 2) into the hole on the body below the sander's disc. Make sure the flat surface of the rod is oriented in the vertical position and is securely tightened in place using two set screws.
2. Slide the pivot bracket (Fig. D - 3) all the way onto the rod and tighten the set screw.
3. The table can also be installed to the support block (Fig. E - 1) beside the body for the vertical belt sanding operation.

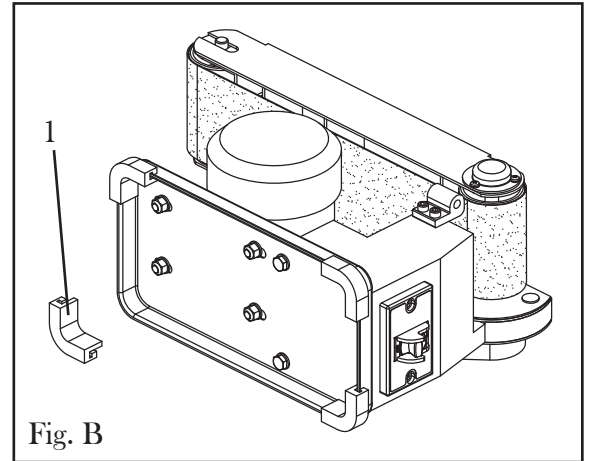

Fig. B

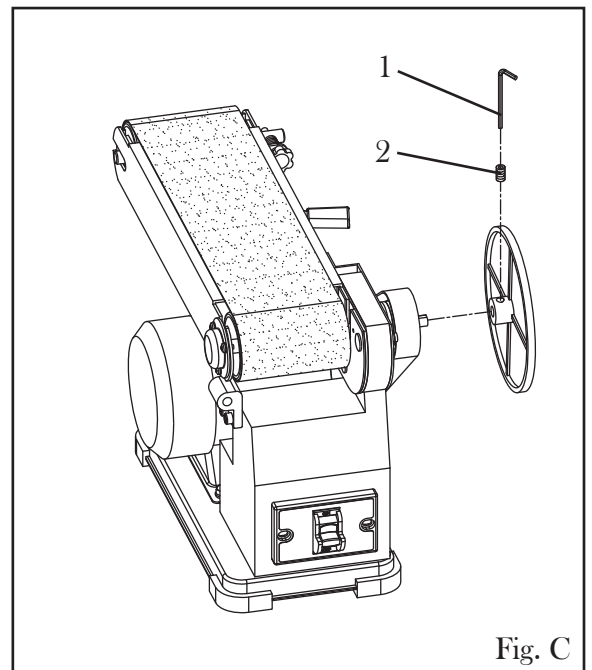

Fig. C

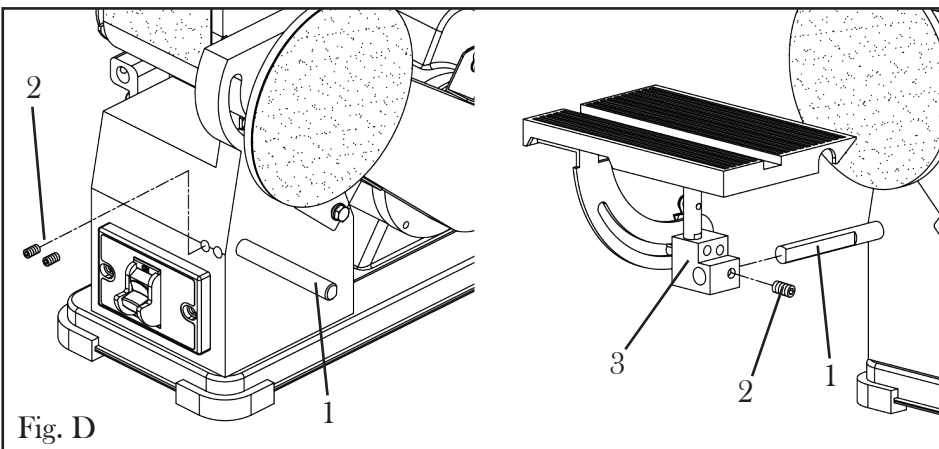

Fig. D

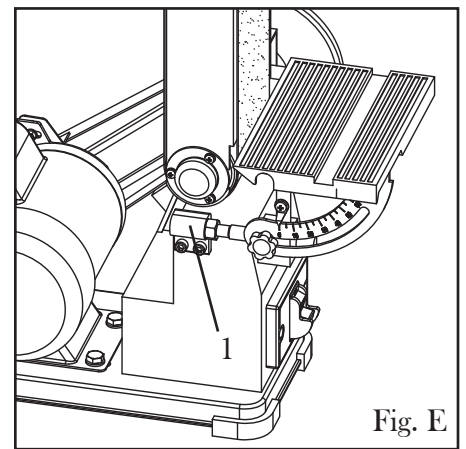

Fig. E

ASSEMBLY AND ADJUSTMENTS

MOUNTING THE WORK STOP

1. Loosen and remove the hex bolt (Fig. F - 1) and the flat washer (Fig. F - 2) from the plate.
2. Install the work stop and replace the hex bolt and washer to hold it in place.

LEVELING TABLE ASSEMBLY

1. Place a combination square (not included, Fig. G - 1) on the table so that it contacts both the table and the sanding disc.
2. If the table is not at a perfect 90 degrees with the disc, loosen the angle lock knob (Fig. G - 3) and tilt the table retighten the knob to hold the table in place.
3. Once the table is squared, loosen the angle pointer screw (Fig. G - 2) and adjust the pointer so it is aiming directly at 0°. Retighten the screw.

ADJUSTING THE BELT'S TRACKING

1. Turn on the switch. If the belt looks like it is going to slide off either drum, the belt tracking needs to be adjusted.
2. Turn the belt tracking adjustment knob (Fig. H - 1) until the belt rides in the center of both drums.

ADJUSTING THE SANDING BELT FOR VERTICAL OPERATION

1. Using a spanner, loosen the two hex nuts (Fig. I - 1) until the belt frame can be moved up and down.
2. Once the desired angle has been reached, retighten the hex nuts to secure the plate in place.

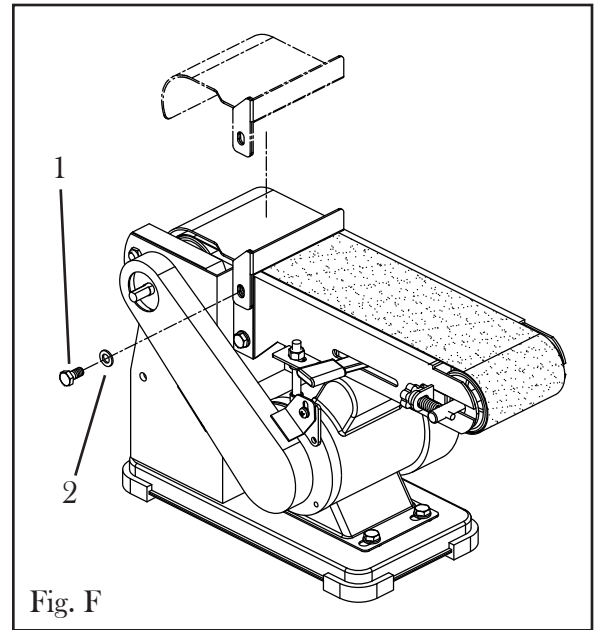

Fig. F

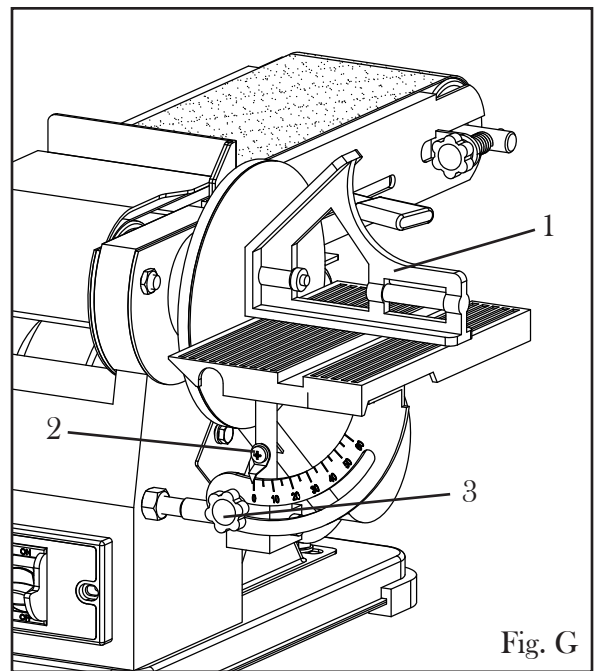

Fig. G

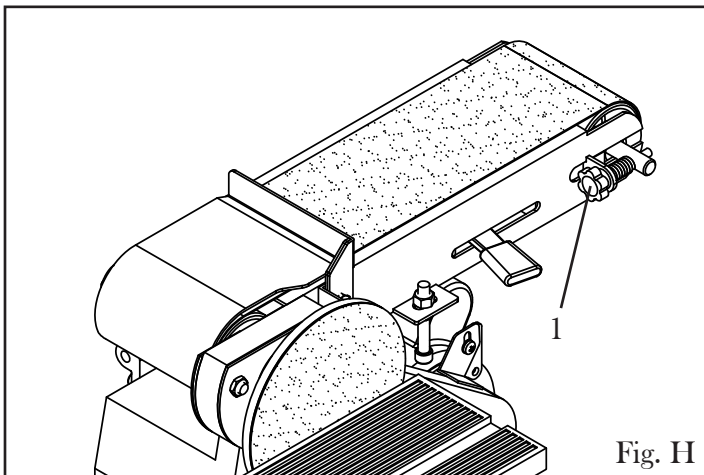

Fig. H

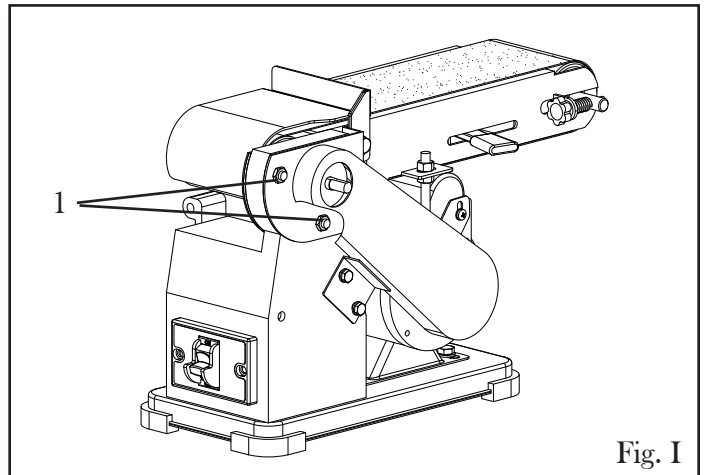

Fig. I

OPERATION

ON/OFF SWITCH

1. To turn sander ON, insert the safety key into the key slot in the center of the switch.
2. Push key firmly into the slot, then push switch to the ON position to start the sander.
3. To turn the sander OFF push switch to the OFF position.
4. Remove the safety key when the sander has come to a complete stop by gently pulling it forward and out.



WARNING: The keyed switch is intended to prevent unauthorized use of the sander. Remove the safety key whenever the sander is not in use. Place the key in a safe place and out of the reach of children.

SURFACE SANDING ON SANDING BELT

Hold the workpiece firmly with both hands. Keep fingers away from sanding belt. Keep the workpiece end against the backstop and move it slowly across the sanding belt. Apply enough pressure to remove material; excessive pressure will reduce sanding efficiency.

SANDING INSIDE CURVES

When sanding inside-curves on the belt-sander, always sand on the idler drum end of the work support station (right side of the machine as shown in diagram). Hold the workpiece firmly, keeping fingers away from the sanding belt. Keep the curve pressed firmly against the idler drum, moving the work evenly back and forth across the drum.

Note: Use extra caution when sanding very thin pieces, and apply only enough pressure to allow the sanding belt to remove the material.

END SANDING AND OUTSIDE CURVE SANDING WITH THE DISC

Use for sanding the ends of small and narrow workpieces and outside curved edges. Always work on the left side of the disc (downward rotation side), holding the workpiece firmly with light pressure against the sanding disc.



CAUTION: To avoid personal injury and/or damage to the workpiece, become familiar with the rotation of the belt and disc sanding surfaces.

The disc sander rotates counterclockwise, downward toward the table on the left side of the disc and upward from the table on the right side of the disc. Always use the left side of the disc; using the right side of the disc will cause the workpiece to fly up or kickback and could result in injury. Review this instruction manual for correct operation, adjustments, and basic sanding operations.

MITER GAUGE - DISC SANDER

A miter-gauge is supplied with your sander, and can be used on the disc table. The miter gauge head can be set anywhere up to 60° (right or left) by loosening the lock-knob, setting the miter gauge head to the desired angle, and retightening the lock-knob.

SANDING SMALL END GRAIN AND OTHER SMALL SURFACES USING MITER GAUGE

Use of the miter gauge is recommended for sanding small end surfaces on the sanding disc.

Note: Always move the workpiece across the sanding disc from the left side towards the right side, and be sure to hold the workpiece down tightly onto the table surface.

MAINTENANCE

WARNING: For your own safety, turn the switch OFF and remove the plug from the electrical outlet before adjusting or performing maintenance or lubrication work on the belt/disc sander.

Before using, check to make sure parts are not damaged, missing, or worn. Check for alignment of moving parts, binding of moving parts, improper mounting, or any other conditions that may affect the sander operation. If any of these conditions exist, do not use the sander until parts are replaced or the sander is properly repaired. Frequently blow or vacuum dust from all sanding parts and motor housing.

WARNING: Any attempt to repair or replace electrical parts on this tool may be hazardous. Repairs should be done by a qualified service technician.

CHANGING THE SANDING DISC

1. Remove the work table from the sanding disc.
2. Remove the used sanding disc. A WEN 2020 Heat Gun can help to soften up the adhesive to make for an easier, cleaner removal.
3. Wipe the sanding disc plate clean.
4. Peel the backing from the new sanding disc, align the disc with the plate and press the sanding disc firmly on to the plate.
5. Reinstall the work table and tighten the screws.

CHANGING THE SANDING BELT

1. Release the belt tension lever (Fig. J - 1) to loosen the belt.
2. Slide the old abrasive sanding belt off of the two drums.
3. Slide the new abrasive belt onto the two drums.
4. Tighten the belt tension lever.
5. Turn on the sander under no load to test the new belt. If the belt tracks to one side, follow the procedure for belt tracking adjustment found on page 9.

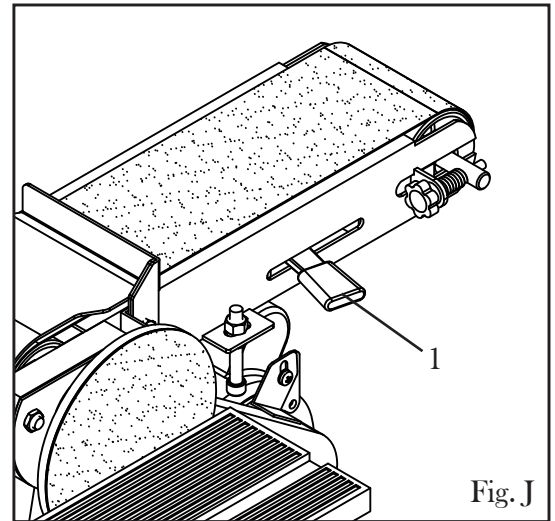

Fig. J

TROUBLESHOOTING

PROBLEM	CAUSE	SOLUTION
Sanding grains easily rub off belt or discs	<ol style="list-style-type: none"> 1) Sanding belt/disc has been stored in an incorrect environment. 2) Sanding belt/disc has been damaged or folded. 	<ol style="list-style-type: none"> 1) Store sanding accessories away from extremely hot/dry temperatures. 2) Store sanding accessories flat—not bent or folded.
Deep sanding grooves or scars in workpiece.	<ol style="list-style-type: none"> 1) Sanding belt/disc grit is too coarse for the desired finish. 2) Workpiece sanded across the grain. 3) Too much sanding force on workpiece. 4) Workpiece held still against belt-disc for too long. 	<ol style="list-style-type: none"> 1) Use a finer-grit sanding accessory. 2) Sand with the grain of the wood. 3) Reduce pressure on workpiece while sanding. 4) Keep workpiece moving while sanding on the sanding accessory.
Sanding surface clogs quickly	<ol style="list-style-type: none"> 1) Too much pressure against belt/disc 2) Sanding softwood. 	<ol style="list-style-type: none"> 1) Reduce pressure on workpiece while sanding. 2) Use different stock/sanding accessories, or accept that this will happen and plan on cleaning or replacing belts/discs frequently.
Burns on workpiece	<ol style="list-style-type: none"> 1) Use a sanding grit that is too fine. 2) Using too much pressure. 3) Work held still for too long. 4) Sanding disc/belt loaded with debris. 	<ol style="list-style-type: none"> 1) Use a coarser-grit sanding accessory. 2) Reduce sanding pressure on workpiece 3) Do not keep workpiece in one place for too long. 4) Clean or replace the disc or belt.
Sander does not turn on	<ol style="list-style-type: none"> 1) Not plugged in to an electrical outlet 2) Defective power switch 3) Motor or wiring problem 	<ol style="list-style-type: none"> 1) Connect the unit to an outlet. 2) Replace the switch. 3) Have a qualified technician make repairs.
Motor will not start—fuses or circuit breakers tripping/blowing	<ol style="list-style-type: none"> 1) Short circuit in line, cord or plug. 2) Short circuit in motor or loose connections 3) Incorrect fuses or circuit breakers in power line. 	<ol style="list-style-type: none"> 1) Inspect cord or plug for damaged insulation and shorted wires. 2) Inspect all connections on motor for loose or shorted terminals and/or worn insulation. 3) Install correct fuses or circuit breakers or switch tool to an appropriately sized circuit.
Motor overheats	<ol style="list-style-type: none"> 1) Motor overloaded 2) Extension cord too long with an insufficient gauge. 	<ol style="list-style-type: none"> 1) Reduce load on motor (pressure on object being sanded) 2) Utilize an extension cord of appropriate gauge and length or plug tool directly into outlet.
Sander makes excessive noise	<ol style="list-style-type: none"> 1) V-belt is too tight. 	<ol style="list-style-type: none"> 1) A qualified technician needs to loosen.

EXPLODED VIEW AND PARTS LIST

No.	Part Number	Description	Qty.
1	6500-001	Pan Head Screw	6
2	6500-002	Lock Washer	6
3	6500-003	Flat Washer	6
4	6500-004	Bearing House	1
5	6500-005	Ball Bearing	2
6	6500-006	Abrasive Belt	1
7	6500-007	Drive Drum	1
8	6500-008	Work Stop	1
9	6500-009	Sanding Belt Plate	1
10	6500-010	Carriage Bolt	2
11	6500-011	Bearing House	1
12	6500-012	Hex Nut	2
13	6500-013	Support Rod	1
14	6500-014	Spring	1
15	6500-015	Sliding Support	1
16	6500-016	Tracking Adjust Knob	1
17	6500-017	Tension Lever	1
18	6500-018	Hex Head Bolt	1
19	6500-019	Spring	1
20	6500-020	Retaining Ring	2
21	6500-021	Idle Drum Shaft	1
22	6500-022	Ball Bearing	2
23	6500-023	Idle Drum	1
24	6500-024	Socket Head Screw	2
25	6500-025	Support Block	1
26	6500-026	Body	1
27	6500-027	Switch Plate	1
28	6500-028	Switch	1
29	6500-029	Pan Head Screw	3
30	6500-030	Lock Washer	1
31	6500-031	Serrate Washer	1
32	6500-032	Holding Plate	1
33	6500-033	Hex Nut	2
34	6500-034	Set Screw	1
35	6500-035	Idle Pulley	1
36	6500-036	V Belt	1
37	6500-037	Belt Cover	1
38	6500-038	Set Screw	1
39	6500-039	Aluminum Disc	1
40	6500-040	Abrasive Disc	1
41	6500-041	Hex Head Bolt	2
42	6500-042	Flat Washer	2

No.	Part Number	Description	Qty.
43	6500-043	Pan Head Screw	1
44	6500-044	Flat Washer	1
45	6500-045	Flat Washer	1
46	6500-046	Lock Washer	1
47	6500-047	Hex Nut	1
48	6500-048	Hex Head Bolt	2
49	6500-049	Flat Washer	2
50	6500-050	Bushing	1
51	6500-051	Strain Relief Mounting Plate	1
52	6500-052	Flat Washer	2
53	6500-053	Pan Head Screw	2
54	6500-054	Strain Relief	1
55	6500-055	Power Cord	1
56	6500-056	Support Plate	1
57	6500-057	Motor	1
58	6500-058	Hex Head Bolt	4
59	6500-059	Flat Washer	8
60	6500-060	Hex Nut	4
61	6500-061	Motor Pulley	1
62	6500-062	Set Screw	1
63	6500-063	Base	1
64	6500-064	Foot	4
65	6500-065	Flat Washer	4
66	6500-066	Hex Head Bolt	4
67	6500-067	Set Screw	4
68	6500-068	Table Support Rod	1
69	6500-069	Set Screw	2
70	6500-070	Pivot Bracket	1
71	6500-071	Hex Head Bolt	1
72	6500-072	Flat Washer	1
73	6500-073	Flat Washer	1
74	6500-074	Knob	1
75	6500-075	Angle Plate	1
76	6500-076	Pan Head Screw	1
77	6500-077	Pointer	1
78	6500-078	Table Mounting Rod	1
79	6500-079	Table	1
80	6500-080	Miter Gauge	1
81	6500-081	4mm Hex Wrench	1
82	6500-082	3mm Hex Wrench	1
83	6500-083	Spanner	1

EXPLODED VIEW AND PARTS LIST

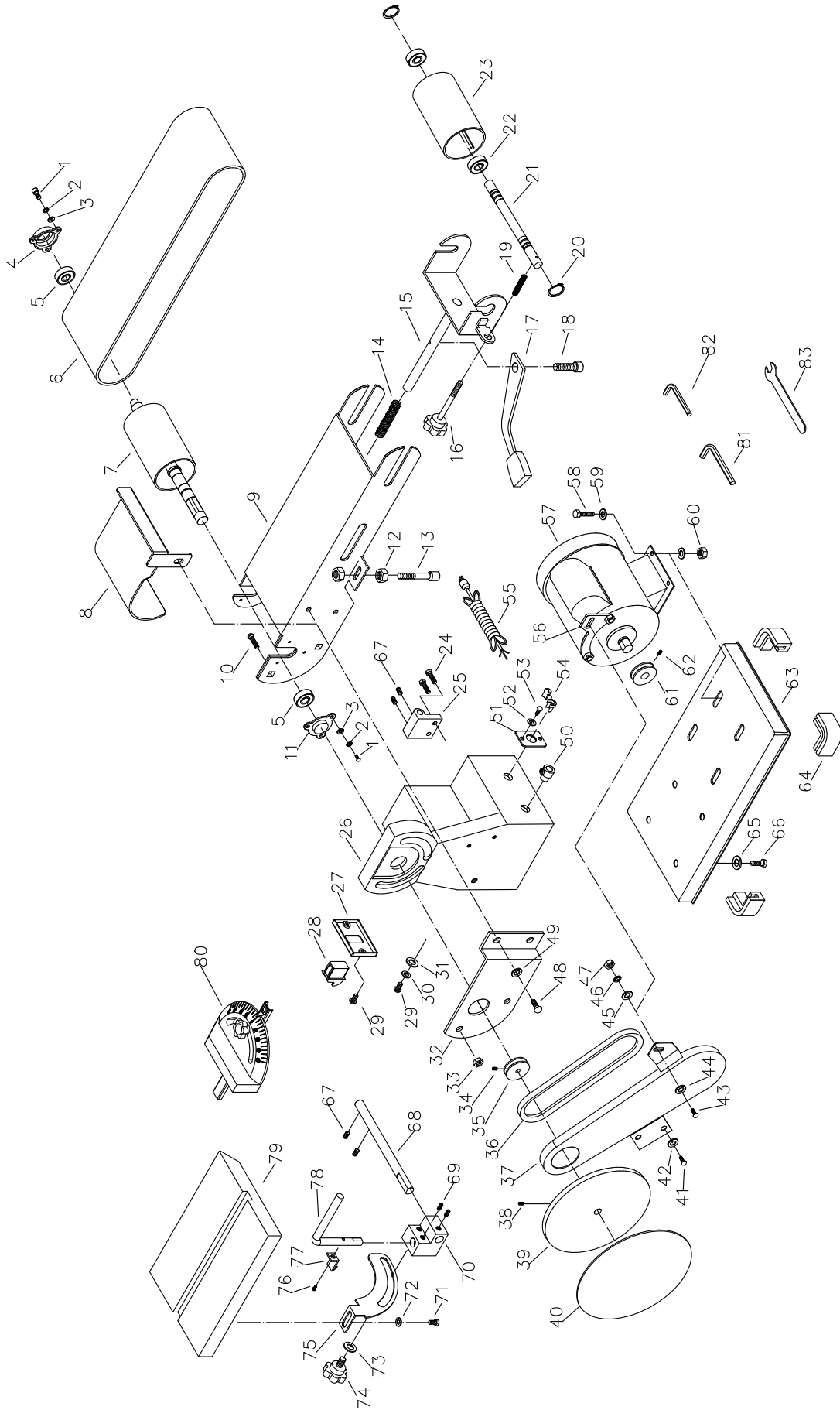

LIMITED TWO YEAR WARRANTY

WEN Products is committed to building tools that are dependable for years. Our warranties are consistent with this commitment and our dedication to quality.

LIMITED WARRANTY OF WEN CONSUMER POWER TOOLS PRODUCTS FOR HOME USE

GREAT LAKES TECHNOLOGIES, LLC (“Seller”) warrants to the original purchaser only, that all WEN consumer power tools will be free from defects in material or workmanship for a period of two (2) years from date of purchase. Ninety days for all WEN products, if the tool is used for professional use.

SELLER’S SOLE OBLIGATION AND YOUR EXCLUSIVE REMEDY under this Limited Warranty and, to the extent permitted by law, any warranty or condition implied by law, shall be the repair or replacement of parts, without charge, which are defective in material or workmanship and which have not been misused, carelessly handled, or misrepaired by persons other than Seller or Authorized Service Center. To make a claim under this Limited Warranty, you must make sure to keep a copy of your proof of purchase that clearly defines the Date of Purchase (month and year) and the Place of Purchase. Place of purchase must be a direct vendor of Great Lakes Technologies, LLC. Third party vendors such as garage sales, pawn shops, resale shops, or any other secondhand merchant void the warranty included with this product. Contact techsupport@wenproducts.com or 1-800-232-1195 to make arrangements for repairs and transportation.

When returning a product for warranty service, the shipping charges must be prepaid by the purchaser. The product must be shipped in its original container (or an equivalent), properly packed to withstand the hazards of shipment. The product must be fully insured with a copy of the warranty card and/or the proof of purchase enclosed. There must also be a description of the problem in order to help our repairs department diagnose and fix the issue. Repairs will be made and the product will be returned and shipped back to the purchaser at no charge.

THIS LIMITED WARRANTY DOES NOT APPLY TO ACCESSORY ITEMS THAT WEAR OUT FROM REGULAR USAGE OVER TIME INCLUDING BELTS, BRUSHES, BLADES, ETC.

ANY IMPLIED WARRANTIES SHALL BE LIMITED IN DURATION TO TWO (2) YEARS FROM DATE OF PURCHASE. SOME STATES IN THE U.S., SOME CANADIAN PROVINCES DO NOT ALLOW LIMITATIONS ON HOW LONG AN IMPLIED WARRANTY LASTS, SO THE ABOVE LIMITATION MAY NOT APPLY TO YOU.

IN NO EVENT SHALL SELLER BE LIABLE FOR ANY INCIDENTAL OR CONSEQUENTIAL DAMAGES (INCLUDING BUT NOT LIMITED TO LIABILITY FOR LOSS OF PROFITS) ARISING FROM THE SALE OR USE OF THIS PRODUCT. SOME STATES IN THE U.S. AND SOME CANADIAN PROVINCES DO NOT ALLOW THE EXCLUSION OR LIMITATION OF INCIDENTAL OR CONSEQUENTIAL DAMAGES, SO THE ABOVE LIMITATION OR EXCLUSION MAY NOT APPLY TO YOU.

THIS LIMITED WARRANTY GIVES YOU SPECIFIC LEGAL RIGHTS, AND YOU MAY ALSO HAVE OTHER RIGHTS WHICH VARY FROM STATE TO STATE IN THE U.S., PROVINCE TO PROVINCE IN CANADA AND FROM COUNTRY TO COUNTRY.

THIS LIMITED WARRANTY APPLIES ONLY TO PORTABLE ELECTRIC TOOLS, BENCH POWER TOOLS, OUTDOOR POWER EQUIPMENT AND PNEUMATIC TOOLS SOLD WITHIN THE UNITED STATES OF AMERICA, CANADA AND THE COMMONWEALTH OF PUERTO RICO. FOR WARRANTY COVERAGE WITHIN OTHER COUNTRIES, CONTACT THE WEN CUSTOMER SUPPORT LINE.

THANKS FOR REMEMBERING

