



# Two-Stage Snow Blower

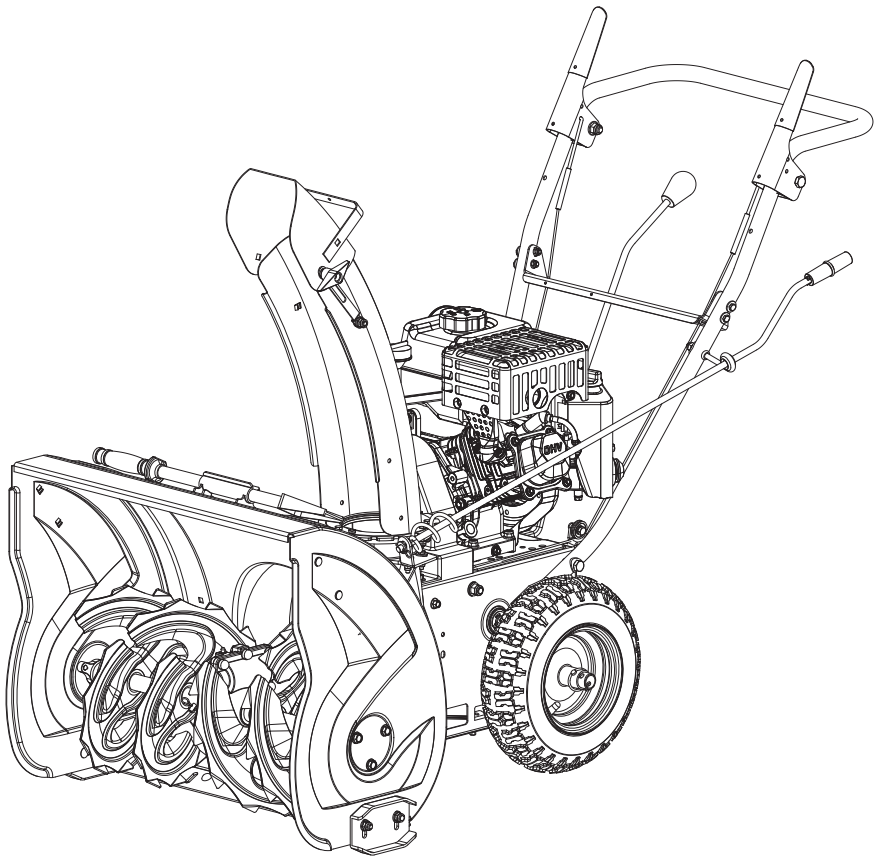
Operator's Manual

**MODEL NUMBER**  
YB6270

**SERIAL NUMBER**

**PURCHASE DATE**

Both model number and serial number may be found on the main label. You should record both of them in a safe place for future use.



---

**FOR YOUR SAFETY**

*READ AND UNDERSTAND THE ENTIRE MANUAL BEFORE OPERATING MACHINE*

---

Your new YARDMAX™ snow blower offers quality construction, and is easy and safe to operate. With proper use and care, it is designed to give you many years of dependable service.

Prepare to experience the durability to take on any job with the ease, portability, and convenience of your new snow blower!

**Discover the YARDMAX Advantage**

At YARDMAX, we understand that land ownership definitely has its privileges, but it also comes with a great deal of responsibility. When duty calls and you need to respond, will you have what it takes to tame the great outdoors?

When looking for outdoor power equipment (OPE) to get the job done right, at the right price, YARDMAX delivers the perfect combination of performance and practicality. YARDMAX has a solution that’s right for you.

**MAX Performance, MAX Value, MAX Support – that’s YARDMAX**

- ✓ Backed by decades of proven manufacturing expertise
- ✓ Enhanced design features come standard
- ✓ Engineered for the best user experience
- ✓ Quality metal parts are used instead of plastic
- ✓ A robust warranty supports all products
- ✓ Budget-friendly prices make it practical



*Up for the job? YARDMAX is.*

---

## TABLE OF CONTENTS

---

Introduction	1
Specifications	3
Symbols	4
Safety	5
Unpacking the Container	7
Contents Supplied	8
Assembly	9
Know Your Machine	12

Adjustment	15
Operation	17
Maintenance	19
Service	20
Storage	23
Troubleshooting	24
Parts Diagram	26
Parts List	29



Carefully read through this entire operator's manual before using your new unit. Pay attention to all cautions and warnings.

This unit is a gasoline engine driven snow blower. It is perfect for tackling heavy snowfall — easily able to cut through snow in excess of a foot or more. It is easy and safe to operate. With proper use and care, it should give you many years of dependable service.

### ENGINE MANUAL

The **Engine Manufacturer** is responsible for all engine-related issues with regards to performance, power rating, specifications, warranty and service. Please refer to the **Engine Manufacturer's** owner/operator's manual, packed separately with your unit, for more information.

### EMISSION CONTROL SYSTEM

This equipment or its engine may include exhaust and evaporative emission control system components required to meet U.S. Environmental Protection Agency (EPA) and/or California Air Resources Board (CARB) regulations. Tampering with emission controls and components by unauthorized personnel may result in severe fines or penalties. Emission controls and components can only be adjusted by an authorized engine manufacturer's service center.

### CALIFORNIA PROPOSITION 65 WARNING

Engine exhaust, some of its constituents and certain product components contain or emit chemicals known to the state of California to cause cancer and birth defects or other reproductive harm.

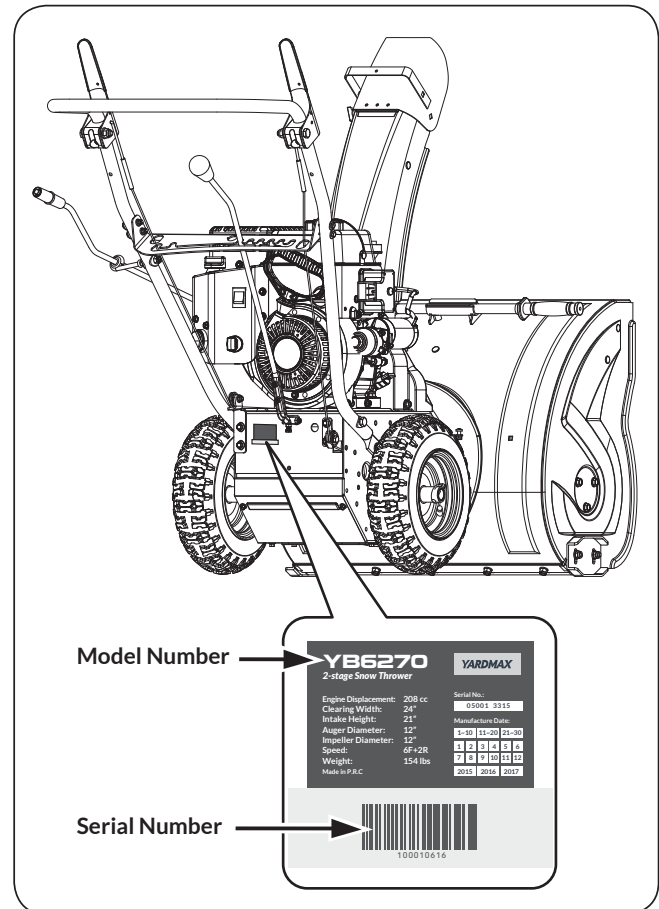
### ENVIRONMENTAL



Recycle unwanted materials instead of disposing of them as waste. All tools, hoses, and packaging should be taken to the local recycling center and disposed of in an environmentally safe way.

### MODEL AND SERIAL NUMBERS

Record the model and serial number as well as date and place of purchase for future reference. Have this information available when ordering parts, optional accessories and when making technical or warranty inquiries.

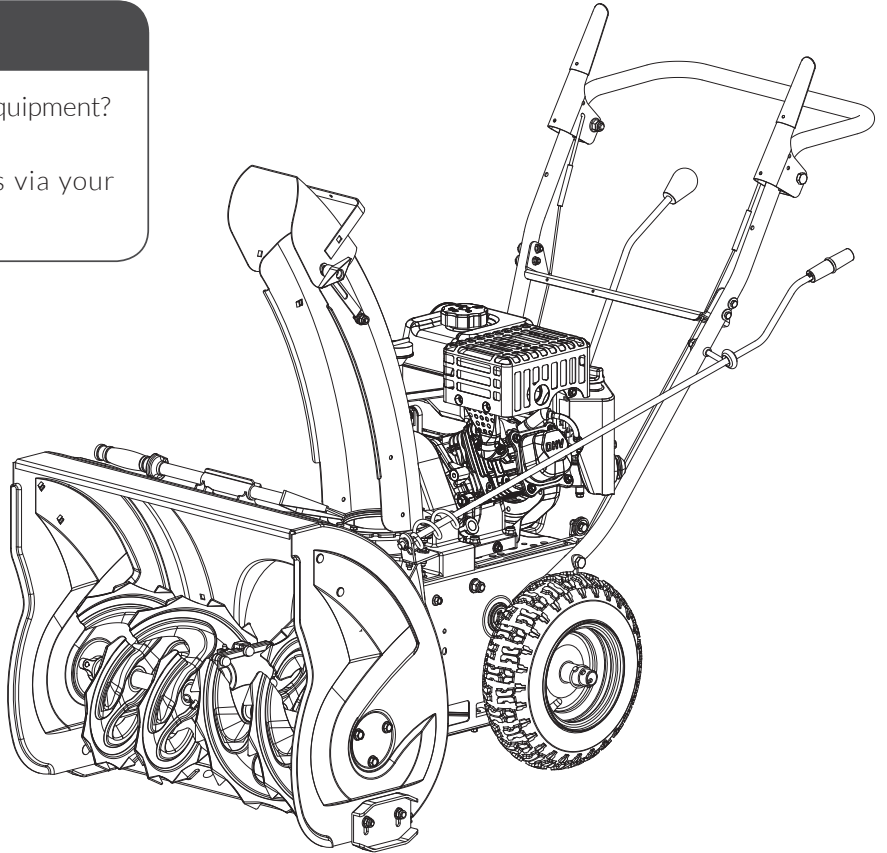


### DISCLAIMER

YARDMAX reserves the right to discontinue, change, and improve its products at any time without notice or obligation to the purchaser. The descriptions and specifications contained in this manual were in effect at printing. Equipment described within this manual may be optional. Some illustrations may not be applicable to your unit.

## SUPPORT

Have questions about your YARDMAX equipment? Call us at 844-YARDMAX, email us at [support@yardmax.com](mailto:support@yardmax.com), or contact us via your favorite social media site.



## SPECIFICATIONS

Model Number	YB6270
Clearing Width	24"
Engine	LCT
Displacement	208cc
Start Type	Electric
Auger Diameter	12"
Impeller Diameter	12"
Chute Control	Crank
Chute Type	Steel
Intake Depth	21"
Speed	13" x 4"
Forward Speeds	6
Reverse Speeds	2

## SYMBOLS

The rating plate on your machine may show symbols. These represent important information about the product or instructions on its use.



Read these instructions carefully.



Wear eye protection.  
Wear hearing protection.



Wear safety footwear.



Keep children and bystanders off and away.



Stop engine and remove ignition key prior to leaving the operator's position.



Only use clean-out tool to clear blockage.  
Never use your hands.



Do not remove or tamper with the protection and safety devices.



No smoking, sparks, or flames.



Do not touch parts that are hot from operation. Serious burns may result.



Stop engine, remove key, read manual before making any repairs or adjustments.



Keep hands out of the inlet and discharge openings while machine is running.



Stay away from rotating augers.



Never direct discharge towards persons or property.

---

# SAFETY

---

## GENERAL SAFETY RULES

### UNDERSTAND YOUR MACHINE

Read this manual and labels affixed to the machine to understand its limitations and potential hazards.

Be thoroughly familiar with the controls and their proper operation. Know how to stop the machine and disengage the controls quickly.

Make sure to read and understand all the instructions and safety precautions as outlined in the **Engine Manufacturer's** manual packed separately with your unit. Do not attempt to operate the machine until you fully understand how to properly operate and maintain the engine and how to avoid accidental injuries and/or property damage.

If the unit is to be used by someone other than original purchaser or loaned, rented, or sold, always provide this manual and any needed safety training before operation. The user can prevent and is responsible for accidents or injuries that may occur to themselves, other people, and property.

Do not force the machine. Use the correct machine for your application. The correct machine will do the job more efficiently and safer at the rate it was designed.

### PERSONAL SAFETY

Do not permit children to operate this machine at any time.

Keep children, pets, and other people not using the unit away from the work area. Be alert and shut off unit if anyone enters work area. Keep children under the watchful care of a responsible adult.

Do not operate the machine while under the influence of drugs, alcohol, or any medication that could affect your ability to use it properly.

Dress properly. Wear heavy long pants, boots, and gloves. Do not wear loose clothing, short pants, or jewelry of any kind. Secure long hair so it is above shoulder level. Keep your hair, clothing, and gloves away from moving parts. Loose clothes, jewelry, or long hair can be caught in moving parts.

Protect eyes, face, and head from objects that may be thrown from the unit. Always wear safety goggles or safety glasses with side shields when operating.

Wear appropriate hearing protection.

Always keep hands and feet away from all moving parts during operation. Moving parts can cut or crush body parts.

Always keep hands and feet away from all pinch points.

Do not touch parts that might be hot from operation. Allow parts to cool before attempting to maintain, adjust, or service.

Stay alert, watch what you are doing, and use common sense when operating the machine.

Do not overreach. Do not operate the machine while barefoot or when wearing sandals or similar lightweight footwear. Wear protective footwear that will protect your feet and improve your footing on slippery surfaces. Keep proper footing and balance at all times. This enables better control of the machine in unexpected situations.

### INSPECT YOUR MACHINE

Check your machine before starting it. Keep guards in place and in working order. Make sure all nuts, bolts, etc., are securely tightened.

Never operate the machine when it is in need of repair or is in poor mechanical condition. Replace damaged, missing, or failed parts before using it. Check for fuel leaks. Keep the machine in safe working condition.

Do not use the machine if the engine's switch does not turn it on or off. Any gasoline powered machine that can't be controlled with the engine switch is dangerous and must be replaced.

Regularly check to see that keys and adjusting wrenches are removed from the machine area before starting it. A wrench or a key that is left attached to a rotating part of the machine may result in personal injury.

Avoid accidental starting. Be sure the engine's switch is off before transporting the machine or performing any maintenance or service on the unit. Transporting or performing maintenance or service on a machine with its switch on invites accidents.

If the machine should start to vibrate abnormally, stop the engine (motor) and check immediately for the cause. Vibration is generally a warning sign of trouble.

**ENGINE SAFETY**

This machine is equipped with an internal combustion engine. Do not use on or near any unimproved, forest covered, or brush covered land unless the exhaust system is equipped with a spark arrester meeting applicable local, state, or federal laws.

In the state of California, a spark arrester is required by law. Other states have similar laws. A spark arrester, if used, must be maintained in effective working order by the operator.

Never start or run the engine inside a closed area. The exhaust fumes are dangerous, containing carbon monoxide, an odorless and deadly gas. Operate this unit only in a well-ventilated outdoor area.

Do not tamper with the engine to run it at excessive speeds. The maximum engine speed is preset by the manufacturer and is within safety limits. See engine manual.

Keep a Class B fire extinguisher on hand when operating this snow blower in dry areas as a precautionary measure.

**FUEL SAFETY**

Fuel is highly flammable, and its vapors can explode if ignited. Take precautions when using to reduce the chance of serious personal injury.

When refilling or draining the fuel tank, use an approved fuel storage container while in a clean, well-ventilated outdoor area. Do not smoke, or allow sparks, open flames, or other sources of ignition near the area while adding fuel or operating the unit. Never fill the fuel tank indoors.

Keep grounded conductive objects, such as tools, away from exposed, live electrical parts and connections to avoid sparking or arcing. These events could ignite fumes or vapors.

Always stop the engine and allow it to cool before filling the fuel tank. Never remove the cap of the fuel tank or add fuel while the engine is running or when the engine is hot. Do not operate the machine with known leaks in the fuel system.

Loosen the fuel tank cap slowly to relieve any pressure in the tank.

Never overfill the fuel tank. Fill the tank to no more than 1/2" below the bottom of the filler neck to provide space for expansion as the heat of the engine can cause fuel to expand.

Replace all fuel tank and container caps securely and wipe up spilled fuel. Never operate the unit without the fuel cap securely in place.

Avoid creating a source of ignition for spilled fuel. If fuel is spilled, do not attempt to start the engine but move the machine away from the area of spillage and avoid creating any source of ignition until fuel vapors have dissipated.

When fuel is spilled on yourself or your clothes, wash your skin and change clothes immediately.

Store fuel in containers specifically designed and approved for this purpose.

Store fuel in a cool, well-ventilated area, safely away from sparks, open flames, or other sources of ignition.

Never store fuel or a machine with fuel in the tank inside a building where fumes may reach a spark, open flame, or any other source of ignition, such as a water heater, furnace, or clothes dryer. Allow the engine to cool before storing in any enclosure.

**SPECIFIC SAFETY RULES**

Do not operate without wearing adequate winter outer garments.

Do not use the machine on a roof.

Do not run the engine indoors, except when starting the engine and for transporting the snow thrower in or out of the building. Open the outside doors; exhaust fumes are dangerous.

Always check overhead and side clearances carefully before operation. Always be aware of traffic when operating along streets or curbs.

Thoroughly inspect the area to be worked. Keep the working area clean and free of toys, doormats, newspapers, sleds, boards, wires and other foreign objects, which could be tripped over or thrown

by the auger/impeller. Check for weak spots on docks, ramps or floors.

Plan your snow-throwing pattern to avoid discharge toward people or areas where property damage can occur.

Do not operate near drop-offs, ditches, or embankments. Machine can suddenly turn over if a wheel is over the edge of a cliff or ditch, or if an edge caves in.

Keep all bystanders, children, and pets at least 75 feet (23m) away. If you are approached, stop the unit immediately.

Use a grounded three-wire extension cord and receptacle for all machines with electric start engines.

Check clutch and brake operation frequently. Adjust and service as required. All motion of drive wheels and auger/impeller must stop quickly when control levers are released.

Let engine and machine adjust to outdoor temperature before starting to clear snow.

Stay alert for hidden hazards or traffic.

Do not overload machine capacity by attempting to clear snow at too fast of a rate.

Do not throw snow any higher than necessary.

Adjust auger housing height to clear gravel or crushed rock surfaces. Exercise extreme caution when operating.

Exercise caution to avoid slipping or falling, especially when operating in reverse. Never operate machine at high transport speeds on slippery surfaces. Always look down and behind before and while backing.

Do not operate on steep slopes. Do not clear snow across the face of slopes. Keep all movement on slopes slow and gradual. Do not make sudden changes in speed or direction. Use a slow speed to avoid stops or shifts on slopes. Avoid starting or stopping on a slope. Do not park machine on a slope unless absolutely necessary. When parking on a slope, always block the wheels.

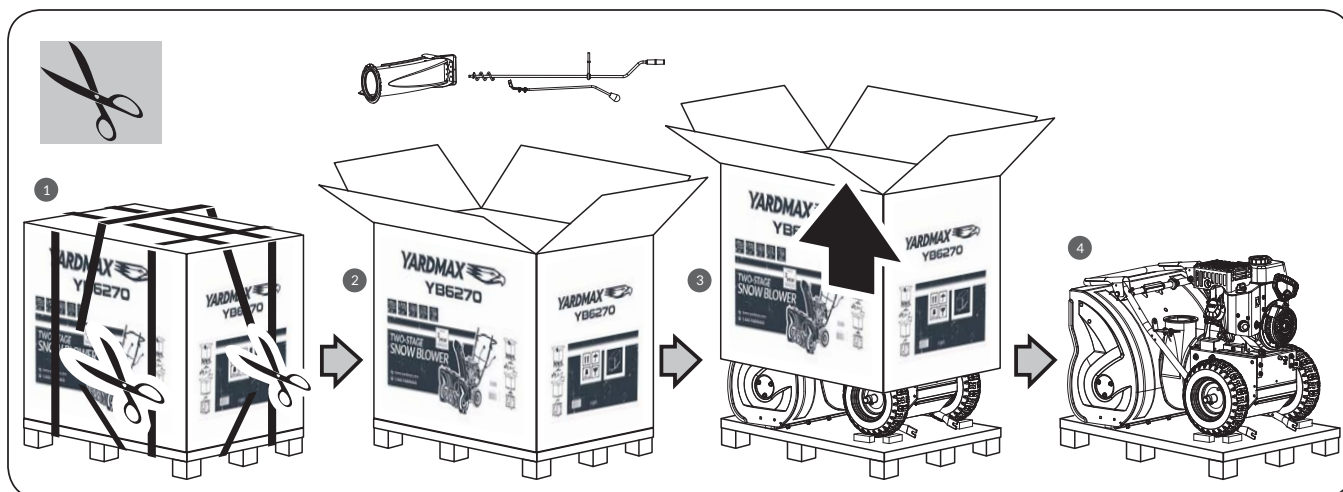
Disengage power to the auger/impeller when transporting or not in use.

Disengage all control levers and stop engine before you leave the operating position (behind the handles). Wait until the auger/impeller comes to a complete stop before unlogging the chute assembly, making any adjustments, or inspections.

Hand contact with the rotating impeller inside the discharge chute is the most common cause of injury associated with snow throwers. Do not unlog chute assembly while engine is running. Shut off engine and remain behind handles until all moving parts have stopped before unlogging. Never put your hand in the discharge or collector openings. Always use the clean-out tool provided to unlog the discharge opening.

## UNPACKING THE CONTAINER

Open the top of box and remove all the loosen parts. Lift off the carton and dispose of properly. (See **Figure 1**)

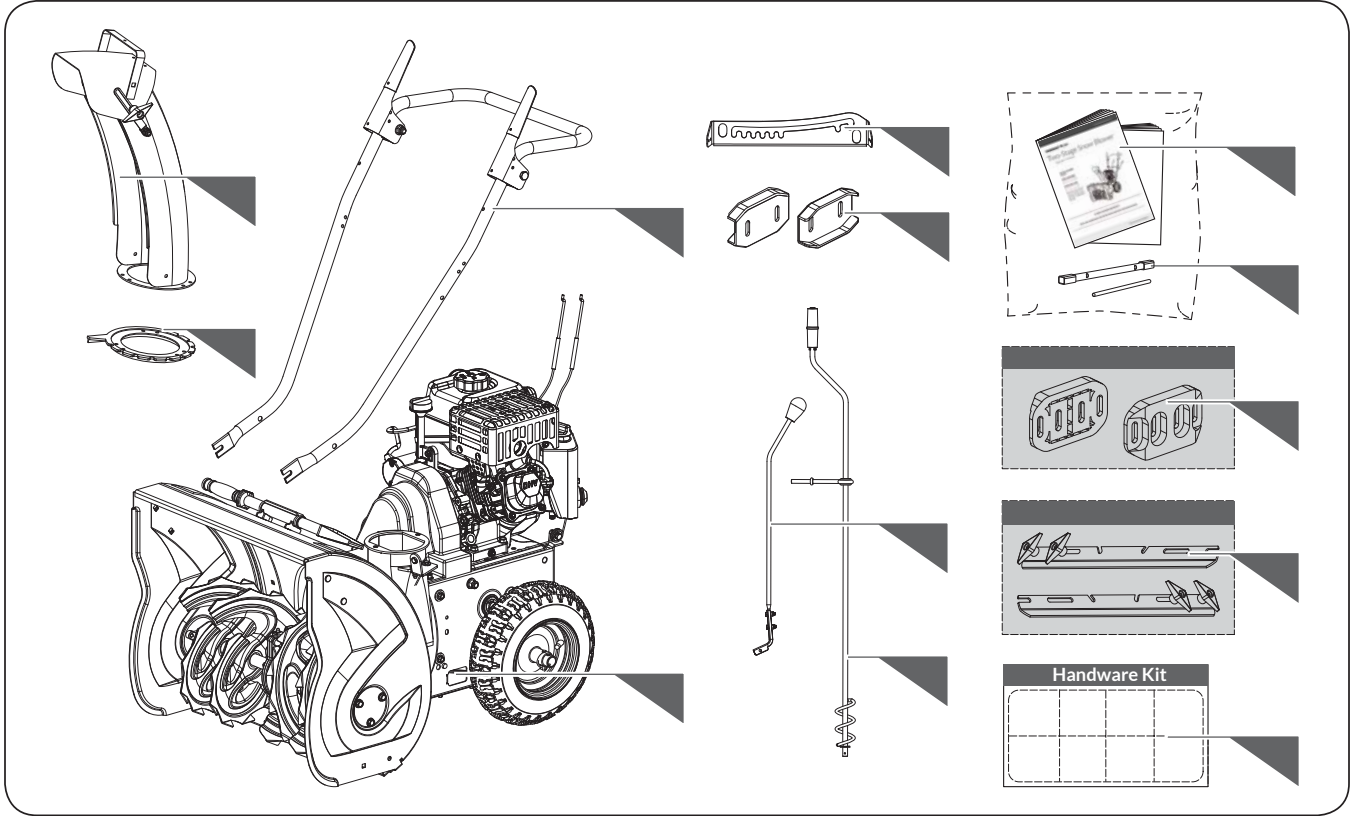


**Figure 1**



## CONTENTS SUPPLIED

Your YARDMAX snow blower comes partially assembled and contains the following:



1. Main Machine
2. Discharge Chute
3. Chute Crank Flange
4. Handlebars
5. Control Panel
6. Skid Shoes
7. Shift Rod
8. Directional Chute Control
9. Operator's Manual & Engine Manual
10. Tools for Spark Plug Assembly
11. Plastic Skid Shoes (Optional)
12. Drift Cutters (Optional)
13. Hardware Kit, Including:

	M10 X 40	X2	<b>1</b>
	M6 X 40	X4	<b>2</b>
	M6 X 30	X1	<b>3</b>

	M6 X 30	X6	<b>4</b>
		X3	
	M8	X1	<b>5</b>
		X1	
	M8x25	X2	<b>6</b>
	M8x20	X2	

### REPLACEMENT PARTS

		X2	<b>7</b>
		X2	
	6 X 37	X2	<b>8</b>

### TOUCH-UP PAINT

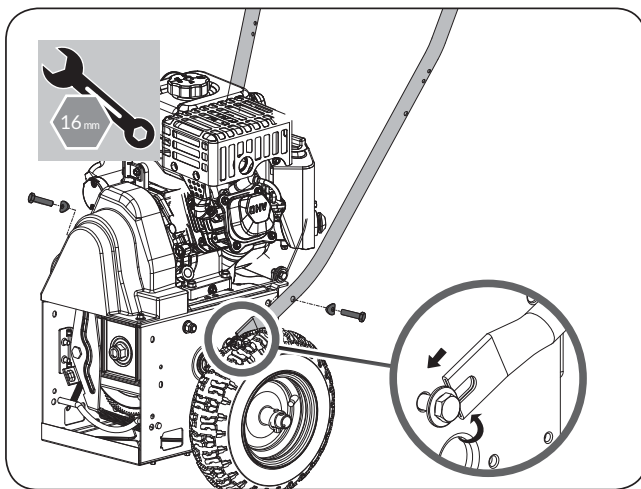
	Orange	X1	<b>9</b>
	Light Gray	X1	

# ASSEMBLY

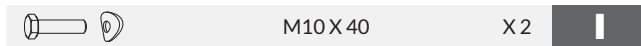
This snow blower was partially assembled at the factory. To assemble your machine follow the below instructions.

## HANDLEBARS

1. Loosen the two bolts on the sides of the transmission housing.
2. Slide the handle slots in-between the transmission and the washer. Finger tighten the bolts to hold the handle in place.
3. Align the holes in the handle with the upper holes on both sides of the transmission housing. Insert the bolts and curved washers and finger tighten to hold in place. (See **Figure 2**)

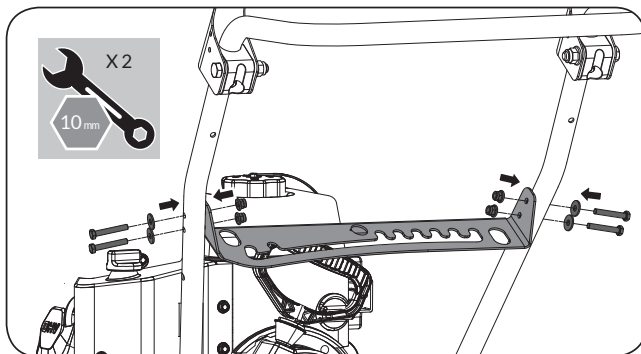


**Figure 2**

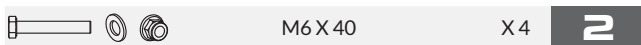


## CONTROL PANEL

1. Secure control panel to the handlebars with screws, washers and nuts until they are finger tight.



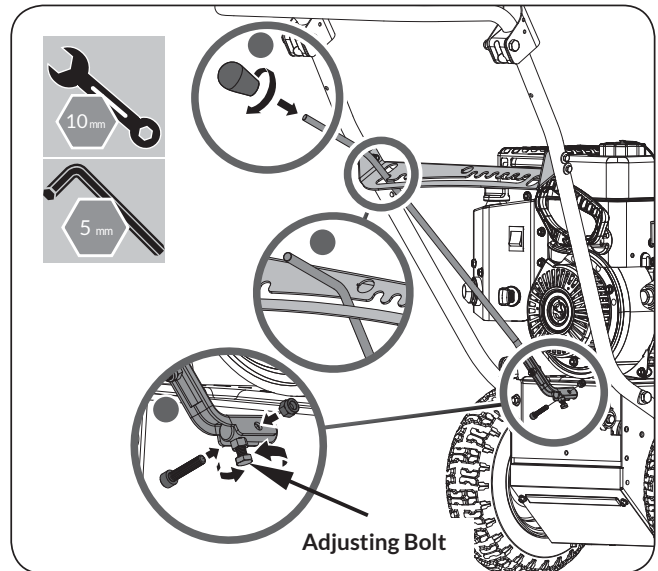
**Figure 3**



2. Once control panel is installed. Securely tighten lower handle and control panel bolts.

## SPEED SHIFT LINKAGE

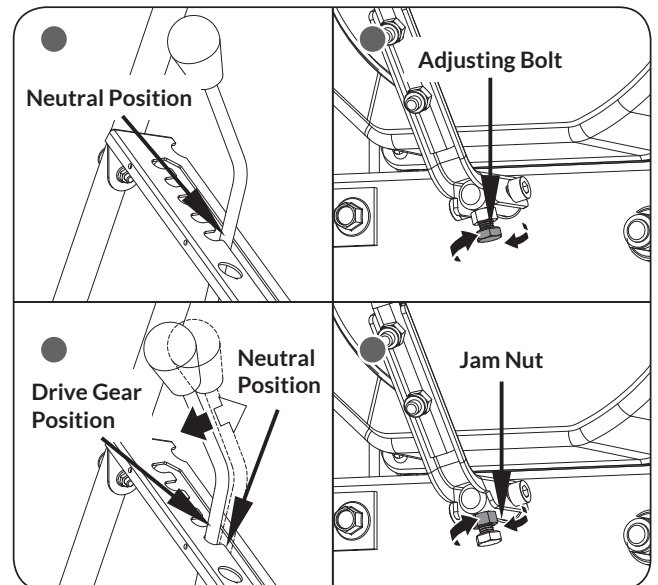
1. Remove the knob to slide the shift lever through the slot in the control panel.
2. The adjusting bolt will need to be loosen to install shift arm (See **Figure 4a #2**). Secure shift lever to the shift arm with screw and nut.
3. Reattach the knob.



**Figure 4a**



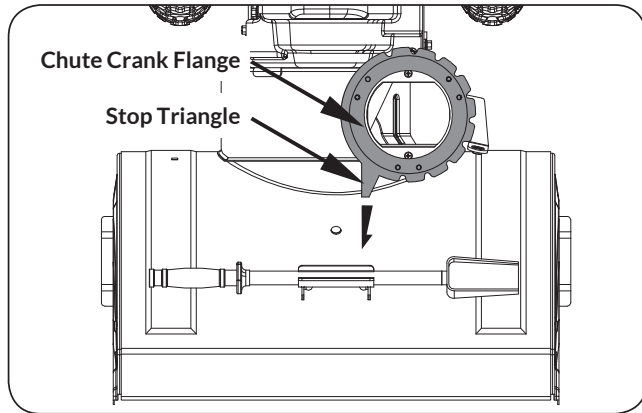
4. Slowly tighten the adjusting bolt until the shift lever has tension with a spring action when shifting from Neutral to a Drive Gear position.



**Figure 4b**

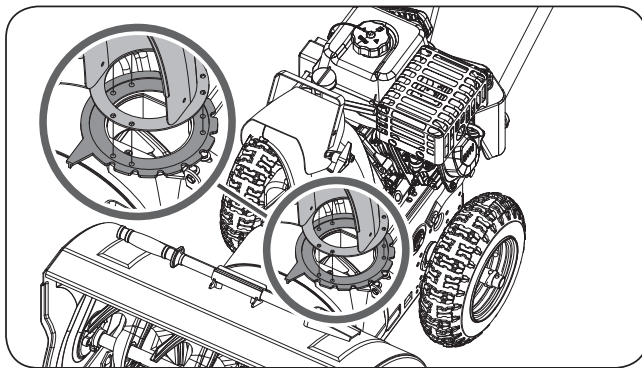
### DISCHARGE CHUTE

1. Sit the chute crank flange on top of the impeller housing. Make sure the stop triangle points forward so that the notched edge are on the left side and the pre-greased surface is on the bottom. (See **Figure 5a**)



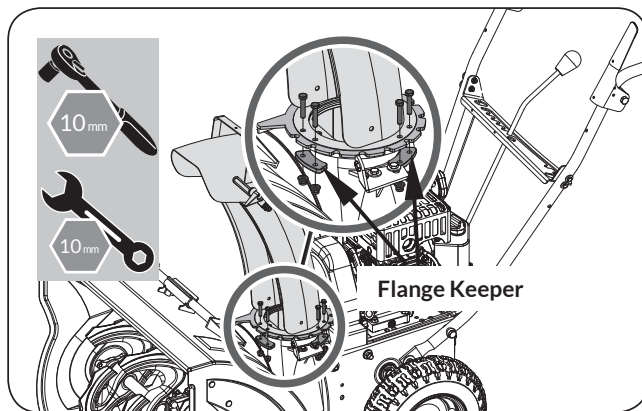
**Figure 5a**

2. Place the discharge chute facing it forward over the chute crank flange. (See **Figure 5b**)





**Figure 5b**

3. Secure the three flange keepers to the bottom of the chute crank flange by sliding the bolts through the chute base holes, sliding the keepers up from the bottom, then securing them with the included nuts. (See **Figure 5c**)

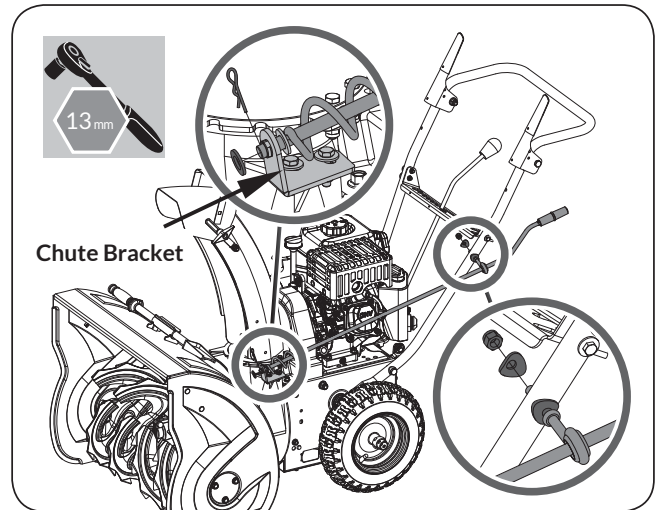


**Figure 5c**



	M6 X 30	X 6	<b>4</b>
		X 3	

### DIRECTIONAL CHUTE CONTROL

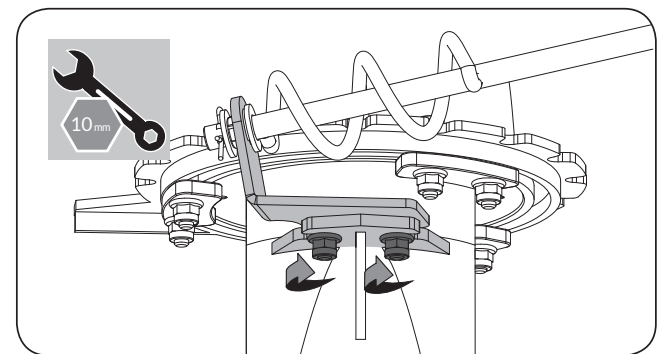
1. Slide the spiral end of the directional chute control lever into the chute bracket.
2. Attach the directional chute control lever to the handlebar through the hole on the left handle by sliding the bolt thru the hole. Use the curved washer and nut to secure it to the handlebar. Leave it finger tight for easier alignment later.
3. Secure the spiral end on the chute bracket by sliding on the flat washer and clevis pin. (See **Figure 6a**)



**Figure 6a**

	M8	X 1	<b>5</b>
		X 1	

4. Make sure the spiral at the bottom is fully engaging with the chute crank flange and tighten the two bolts on the chute bracket. (See **Figure 6b**)

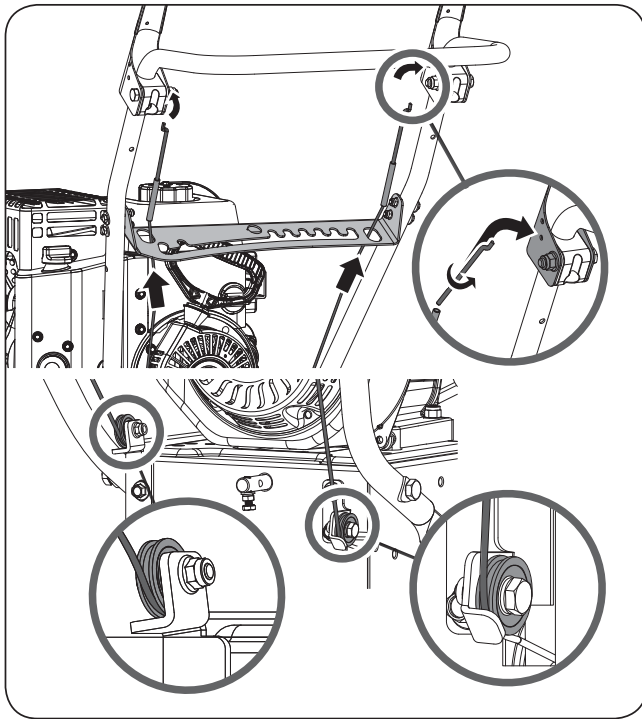


**Figure 6b**

5. Tighten the nut which secures the directional chute control on the handlebar.

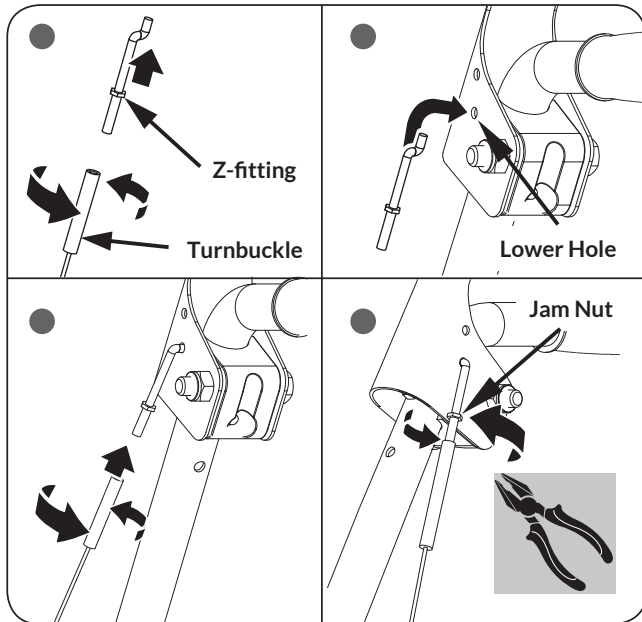
### AUGER CLUTCH CABLE AND DRIVE CLUTCH CABLE

Slide the control cables through the holes in the control panel. Make certain the cables are seated properly in roller guides when hook the cables to the clutch levers.



**Figure 7a**

2. Disconnect the Z-fittings from the turnbuckles and hook them into the lower holes in the clutch levers. Thread the turnbuckles without turning the cables onto Z-fittings until there is no slack in the cables. Do not overtighten the cables. Hold the flats on the turnbuckles with pliers and tighten the jam nuts against the turnbuckles. (See **Figure 7b** steps 1 - 4)

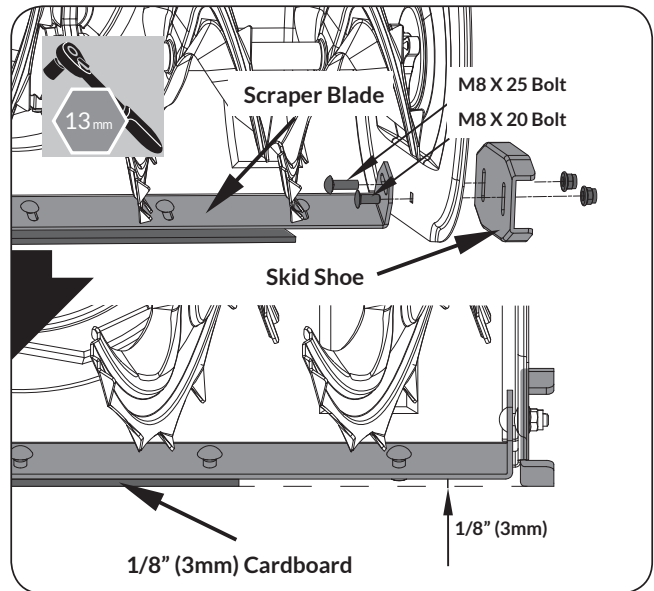


**Figure 7b**

### SKID SHOES

1. Place the machine is on a level and solid surface.

2. Lift the machine so that the scrapper blade is 1/8" (3mm) above the ground, ensuring it is level. A piece of cardboard half the thickness of the snow blower packaging placed under the scrapper blade is recommended.
3. Attach the skid shoes to the sides of auger housing with the bolts and nuts. The shorter M8X20 bolts should be in the front holes while the longer M8X25 bolts in the rear holes. Move the skid shoes down as far as possible. Be sure both skid shoes are adjusted evenly. Tighten securely. (See **Figure 8**)



**Figure 8**

	M8x25	X 2	<b>6</b>
	M8x20	X 2	

4. Remove the 1/8" (3mm) spacer you used from under the scrapper blade.

### TIRES

The tires are over-inflated at factory for shipping purposes. Check the pressure in the tires prior to usage. Reduce or increase air pressure to ensure equal tire pressure to the manufacturer's recommended pressure. The recommended air pressure can be found on the tire sidewall.



*Under any circumstance do not exceed manufacturer's recommended pressure. Excessive pressure when seating beads may cause tire/rim assembly to burst with force sufficient to cause serious injury. Refer to side wall of tire for recommended pressure.*



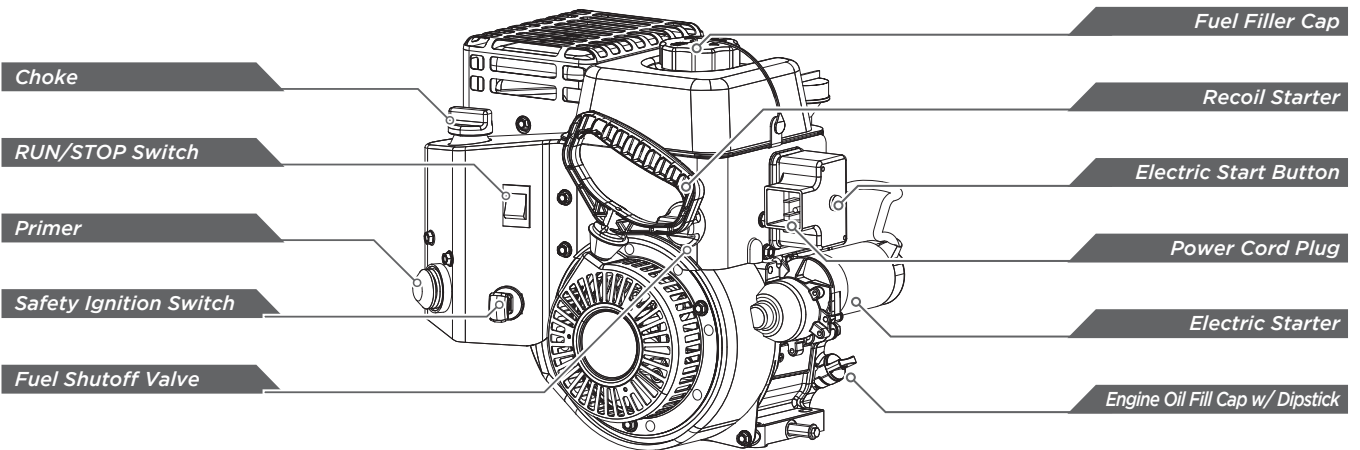
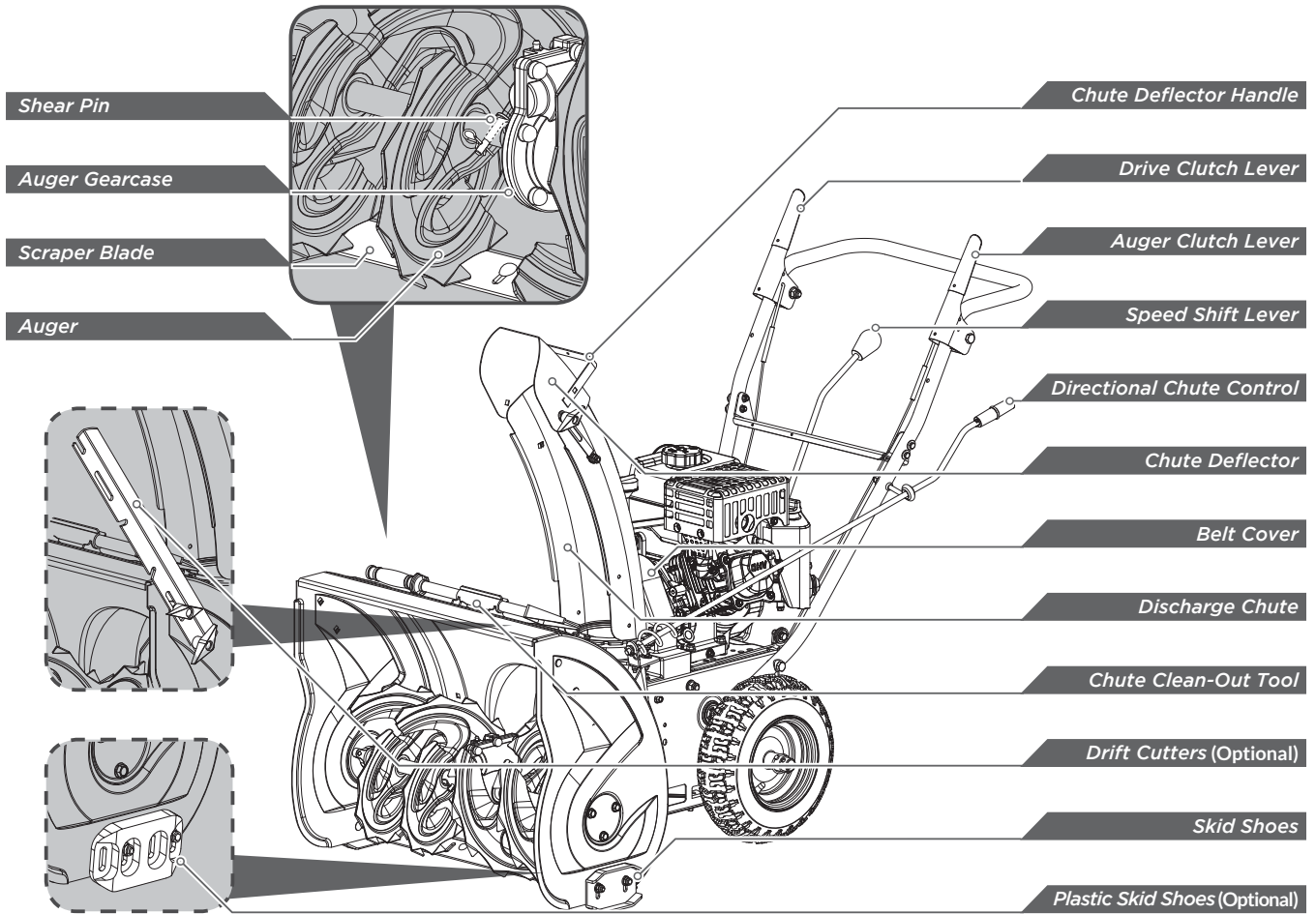
*Equal tire pressure should be maintained at all times. If the tire pressure is not equal in both tires, the machine may not travel in a straight path and the scrapper blade may wear unevenly.*



*Keep tires free of gasoline and oil, which can harm rubber.*

# KNOW YOUR MACHINE

## FEATURES AND CONTROLS



## SPEED SHIFT LEVER

- » The speed shift lever has 8 positions: 6 forward speeds and 2 reverse. To change speeds, move the speed shift lever to the desired position. The lever locks in a notch at each speed selection.



*Always release the drive clutch lever before changing speeds. Failure to do so will result in damage to the snow blower.*

- » For easier snow removal, we recommend slower speeds when removing heavier snow. Faster speeds are better for when removing lighter snow and transporting the snow blower. It is recommended that you use a slower speed until you are familiar with the operation of the snow blower.



*If the engine slows down under a load or the wheels slip, shift the machine into a lower gear.*



*If the front of the machine rides up, shift the machine into a lower gear. If the front continues to ride up, lift up on the handles.*

## DIRECTIONAL CHUTE CONTROL

- » Rotate the directional chute control clockwise to move the discharge chute to the left; counterclockwise to move the chute to the right.



## CHUTE DEFLECTOR

- » To adjust the placement and angle of the snow discharge loosen the wingnut on the side of the deflector chute, move the handle forward to place the snow low and near the machine, pull the handle back to throw the snow further up and away from the machine. Retighten the wingnut to ensure the deflector remains where you would like it.

## DRIVE CLUTCH LEVER

- » Squeeze the clutch lever against the handgrip to engage the transmission. Release to disengage.



*Always release the drive clutch lever before changing speeds. Failure to do so will result in damage to the snow blower.*

## AUGER CLUTCH LEVER

- » Squeeze the clutch lever against the handgrip to engage the auger and start snow blowing. Release to disengage.



## SCRAPER BLADE & SKID SHOES

- » The scraper blade allows better contact with the surface being cleared. It also prevents damage to the housing from normal use.

- » The skid shoes are located on each side of the auger housing and control the distance between the scraper blade and the ground. Adjust skid shoes equally to keep the scraper blade level with the ground.

- » The scraper blade & skid shoes are subject to wear and damage. Both scraper blade and skid shoes are adjustable to compensate for wear. They should be checked and adjusted periodically. Replace when necessary.

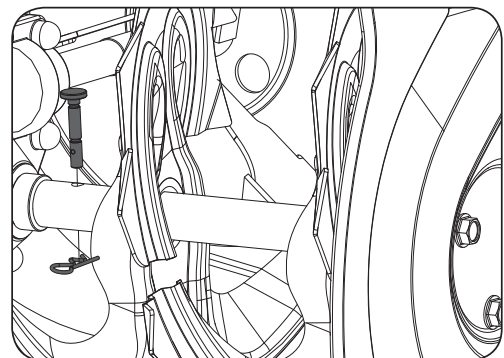
- » Both scraper blade and skid shoes have two wear edges. When one side wears out, they can be rotated 180° to use the other edge.



*Damage to auger housing will result if scraper blade wears down too far.*

## SHEAR PINS

- » The augers are secured to the auger shaft with shear pins and clevis pins. If the auger should strike a foreign object or ice jam, the snow blower is designed so that the pins may shear, preventing damage to any other components. If augers will not turn, check to see if the pins have sheared. Replace the shear pins if necessary.





*Do not substitute. Use only original equipment shear pins as supplied with your snow blower.*

#### AUGER

- » When engaged, the augers rotate and pull snow into the auger housing.

#### DISCHARGE CHUTE

- » Snow drawn into the auger housing is discharged out the discharge chute.

#### CHUTE CLEAN-OUT TOOL



*Never use your hands to clear a clogged discharge chute. Shut off engine and remain behind handles until all moving parts have stopped before unclogging.*

- » The chute clean-out tool is conveniently fastened to the rear of the auger housing with a mounting clip.
- » Should snow and ice become lodged in the discharge chute during operation, proceed as follows to safely clean the discharge chute and chute opening:



1. Release the auger clutch lever and shut off the engine.
2. Remove the clean-out tool from the clip which secures it to the rear of the auger housing.
3. Grasp the tool firmly by the handle and push and twist the tool into the discharge chute to dislodge the blockage.
4. Refasten the clean-out tool to the mounting clip on the rear of the auger housing.
5. Make sure the discharge chute is pointed in a safe direction (no vehicles, buildings, people, or other objects are in the direction of discharge). Restart the engine. While standing in the operator's position (behind the snow blower), engage the auger control for a few seconds to clear any remaining snow and ice from the auger housing and the discharge chute.

#### FUEL SHUTOFF VALVE

- » Always operate the snow blower with the fuel shut-off valve in the OPEN position. Close the valve when you do not use the machine.

#### CHOKE CONTROL



The choke control is used to choke the carburetor and assist in starting the engine. The choke control switches between the CHOKE CLOSED  and CHOKE OPEN  positions.



*Never use choke to stop engine.*

#### PRIMER



Press the primer to pump additional fuel from the carburetor to the cylinder for improved cold weather starting.

#### RECOIL STARTER HANDLE



The handle is used to start the engine.

#### SAFETY IGNITION SWITCH



Insert the safety ignition key for engine to start and run. To stop the engine, remove the key.

#### RUN/STOP SWITCH



Used to stop the engine. Move switch to STOP position to stop engine. Place switch in RUN position for engine to start and run.

#### ELECTRIC STARTER & START BUTTON



The electric starter will start a properly choked and primed engine when start button (120V AC) is pushed.



To start the machine, connect the electric starter to an electric power source with an approved extension cord and press the start button.



*Thoroughly inspect the electrical cord before using the machine. If the cord is damaged, do not operate the machine. Replace or repair the damaged cord immediately.*

*Connect extension cord to the electric starter plug-in first and then to a power outlet; disconnect the extension cord from the power outlet first and then from the machine.*

*To prevent damaging the electric starter, do not run it more than 5 continuous seconds each time you try to start. Wait 10 seconds between each attempt.*

# ADJUSTMENT

## SKID SHOES

Position the skid shoes based on surface conditions. For removal of snow in normal conditions, such as a paved driveway or sidewalk, place skid shoes in the higher position to give a 1/8" (3mm) clearance between the scraper blade and the ground. Use a middle or lower position when the area to be cleared is uneven.

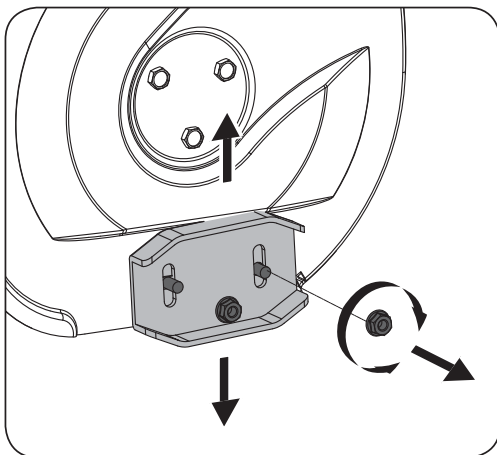


*It is not recommended to operate the snow blower on gravel as it can easily pick up and throw by the impeller, causing personal injury or damage to the snow thrower and surrounding property.*

If you choose to operate the snow thrower on a gravel surface, use extra caution and keep the skid shoes in position for maximum clearance between the ground and the scraper blade.



*Always adjust skid shoes after adjusting scraper blade to prevent premature wear to scraper blade or damage to auger housing.*



**Figure 9**



To adjust the skid shoes:

1. Loosen the four hex nuts (two on each side) and carriage bolts. Move skid shoes to desired position.
2. Make sure the entire bottom surface of skid shoe is against the ground to avoid uneven wear on the skid shoes.
3. Retighten nuts and bolts securely.

## AUGER CLUTCH AND DRIVE CLUTCH



When auger clutch lever or drive clutch lever is released and in the disengaged position, the cable should have very little slack.



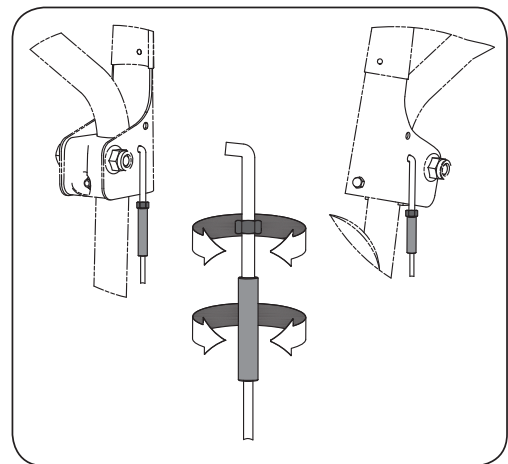
Auger must stop within 5 seconds when the auger clutch lever is released. If auger clutch does not engage or disengage properly, adjust auger clutch before operation.



If the snow blower's drive is disengaging intermittently during operation, or it drives when you release the drive clutch lever, adjust the drive clutch before operation.



Both auger clutch and drive clutch can be adjusted at either end of their control cables.



**Figure 10**

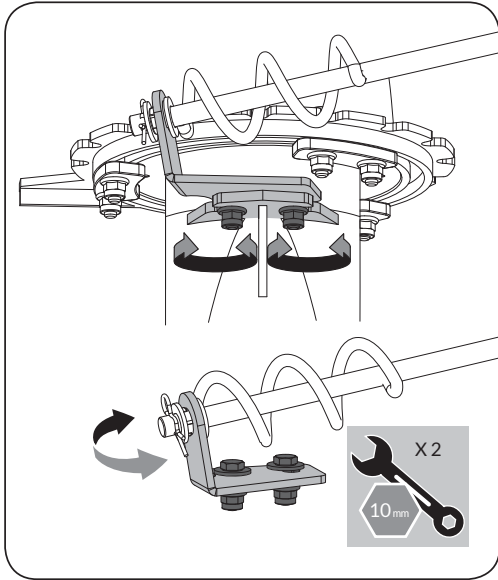
1. Loosen lock nut on adjustment turnbuckle.
2. Turn the adjustment turnbuckle up and down to increase cable tension or provide more slack.
3. Retighten lock nut.

## CHUTE BRACKET



If the spiral at the bottom of the directional chute control lever is not fully engaging with the chute assembly, the chute bracket must be adjusted.





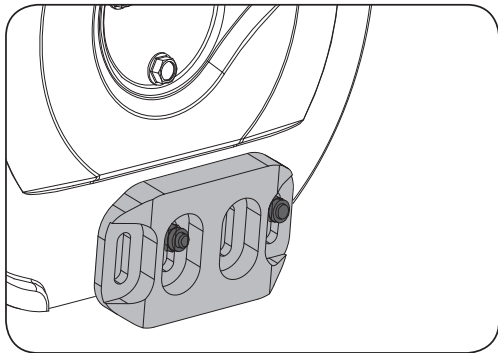
**Figure 11**

» To do so:

1. Loosen the two nuts which secure the chute bracket and reposition it slightly.
2. Retighten the nuts.

**PLASTIC SKID SHOES (OPTIONAL)**

» Optional reversible poly skid shoes protect decorative surface.

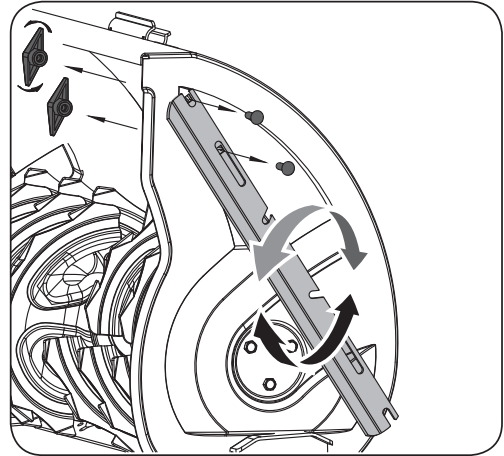


**Figure 12**

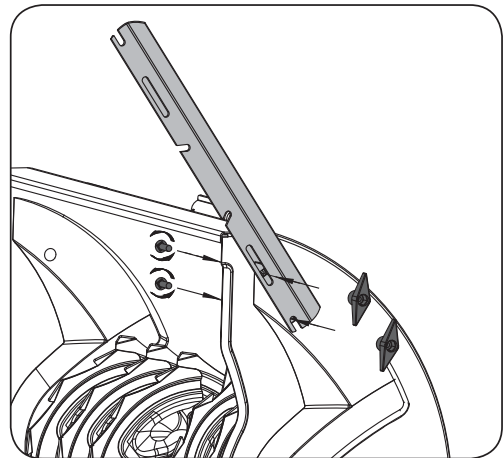
**DRIFT CUTTERS (OPTIONAL)**

Drift cutters break up snow drifts that are taller than the auger housing and direct the snow into the auger.

» Store the drift cutters on the auger housing when not in use. Reposition drift cutters so they face forward as shown. Wing nuts should be fastened on the outside of the auger housing.



**Figure 13a**



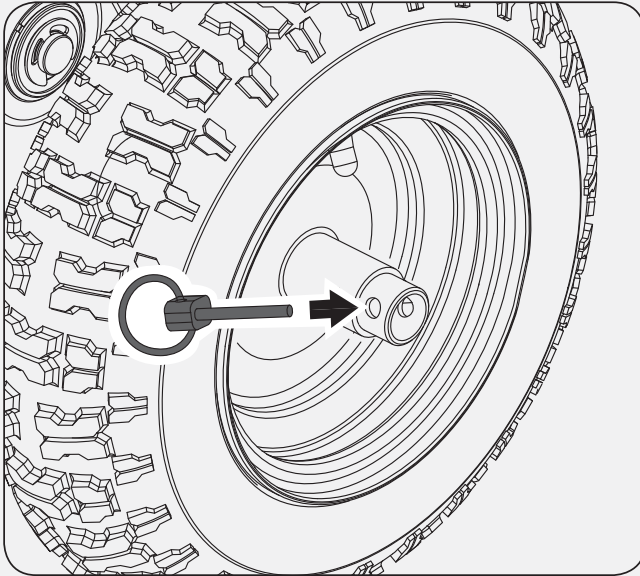
**Figure 13b**

# OPERATION

## FREEWHEELING AND SELF-PROPELLING

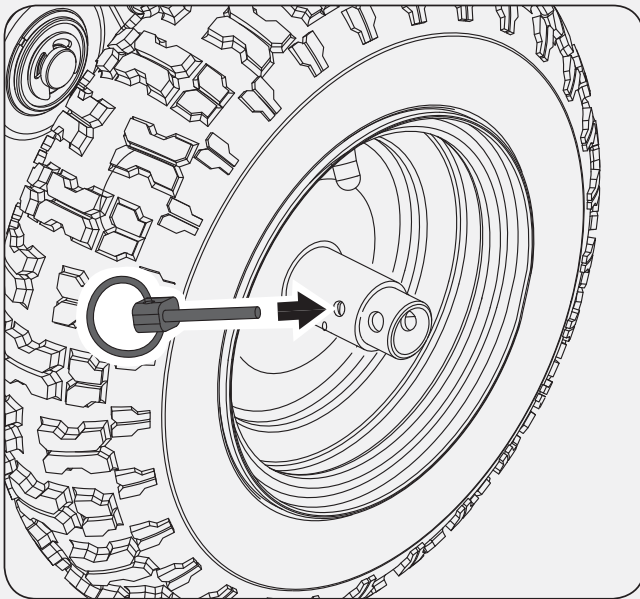
Use the axle lock pin to lock or unlock the right or left wheel. Lock both wheels to increase traction; unlock one wheel to allow for easier turning of the unit; unlock both wheels for freewheeling.

To unlock wheel, slide it inward and insert the axle pin through the outer axle hole, but not through the wheel hub.



**Figure 14a**

To lock wheel, slide it outward and insert the axle pin through the hole in the wheel hub and the outer axle hole.



**Figure 14b**

## STARTING AND STOPPING THE ENGINE




*Before starting the engine, check engine oil level and ensure the engine is served as described in the Engine Manual with the snow blower.*

## COLD START - ELECTRIC STARTER (120V AC)

The engine is equipped with 120V A.C. electric starter and a recoil starter. The electric starter is equipped with a three-wire power cord and plug and is designed to operate at the voltage shown in the label.



*Do not use the electric starter if your household voltage different from the one shown on the electric starter.*

1. Insert safety ignition key into ignition slot until it clicks. Do not turn the key.
2. Be sure fuel shutoff valve is in the OPEN position.
3. Move choke control to CLOSED  position.
4. Push the primer 2 or 3 times. When temperature is below 15°F (-25°C), additional priming may be needed. When temperature is above 50°F (10°C), priming is not necessary.


Over priming may cause flooding, preventing the engine from starting. If you do flood the engine, wait a few minutes before attempting to start and do not push the primer.

Some snow engine are not equipped with primer as priming is not needed.

5. Connect the extension cord to the engine.
6. Plug the other end of the extension cord into a three-wire grounded receptacle.
7. Push starter button until engine starts.



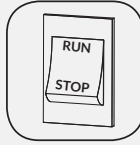
*To prevent damaging the electric GB starter, do not run it more than 5 continuous seconds each time you try to start. Wait 10 seconds between each attempt.*


8. When the engine starts, release the starter button and slowly move the choke control to the OPEN  position.
9. Disconnect the extension cord from thereceptacle first, then from the engine.

**COLD START - RECOIL STARTER**


1. Be sure fuel shutoff valve is in the OPEN position.

2. Place RUN / STOP switch in RUN position.




3. Rotate choke control to CLOSED  position.
4. Push the primer 2 or 3 times. When temperature is below 15°F (-25°C), additional priming may be needed. When temperature is above 50°F (10°C), priming is not necessary.

» Over priming may cause flooding, preventing the engine from starting. If you do flood the engine, wait a few minutes before attempting to start and do not push the primer.

5. Grasp recoil starter handle and pull rope out slowly until it pulls harder. Let rope rewind slowly.
6. Pull rope with a rapid continuous full arm stroke. Do not allow starter rope to snap back.
7. Repeat steps 5 and 6 until engine starts.
8. When the engine starts, release the recoil starter handle and slowly move the choke control to the OPEN  position.

**WARM START**

Follow the steps above, keeping the choke control in the OPEN  position and do not use primer.

» Allow the engine to warm up for a few minutes, engine will not develop full power until it has reached normal operating temperature.

» In snowy and cold conditions, some controls and moving parts may freeze. Do not use excessive force when trying to operate frozen controls. If you have difficulty operating any control or part, start the engine and let it run for a few minutes.

**SNOW BLOWING TIPS**

It is easier and more efficient to remove snow immediately after it falls.

The best time to remove snow is the early morning. At this time the snow is usually dry and has not been exposed to the direct sun and warming temperatures.

Slightly overlap each successive path to ensure all snow will be removed.

For large areas, start in the middle and throw snow to each side, so snow is not cleared more than once.

For extremely heavy snow, reduce the width of snow removal by overlapping previous path and moving slowly.

Throw snow downwind whenever possible.

Keep engine clean and clear of snow during use. This will help air flow and extend engine life.

After snow-throwing is completed, let the engine run for a few minutes to help dry off the moisture on the engine and prevent moving parts from freezing. Engage the auger/impeller to clear any remaining snow from inside the housing. Rotate the discharge chute to prevent it from freezing. Stop the engine, wait for all moving parts to stop, and remove all ice and snow from the snow thrower. With the engine off, pull the recoil starter handle several times to prevent the recoil starter from freezing up.

**TRAVELING**

To travel from one work area to another:

1. Set throttle to slow or part-throttle position.
2. Press down on handle bars enough to raise front of unit slightly off surface.
3. Engage drive clutch without engaging auger clutch.

**TRANSPORT**

*Always shut off engine, remove key, and close fuel shut-off valve when transporting unit on a truck or trailer. Do not transport machine while engine is running.*

Use extra care when loading or unloading unit onto trailer or truck.

Secure unit chassis to transport vehicle. Never secure from rods or linkages that could be damaged.

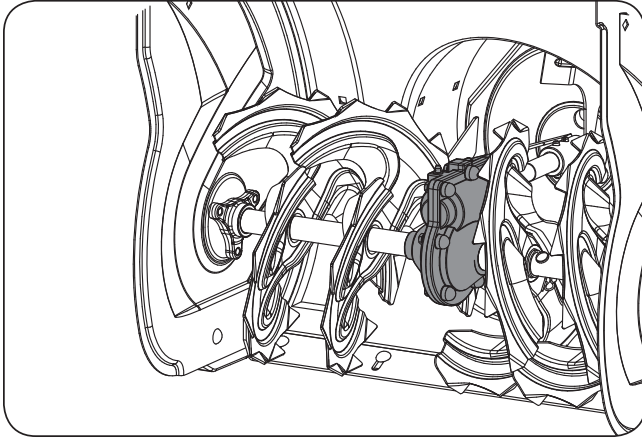
# MAINTENANCE

## ENGINE

Refer to the Engine Operator's Manual.

## LUBRICATION

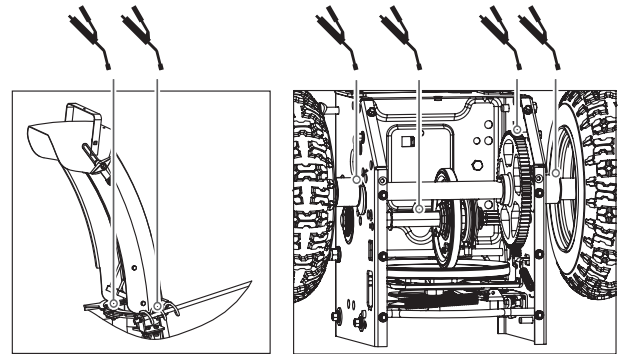
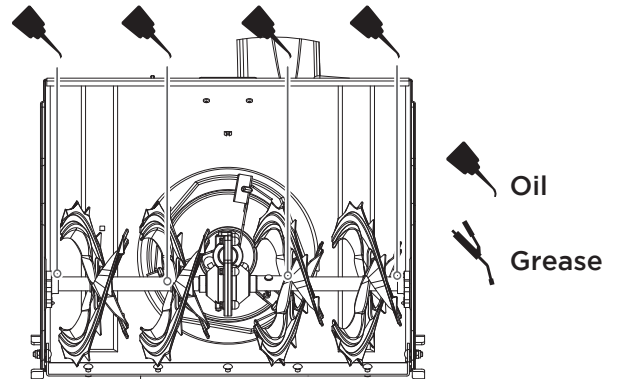
### AUGER GEARBOX



The gearbox was filled with lubricant to the proper level at the factory. Unless there is evidence of leakage or service has been performed on the gearbox, no additional lubricant should be required. If lubricant is required, use GL-5 or GL-6, SAE85-95, EP gear oil lubricant. Do not use synthetic oil.

### GENERAL LUBRICATION

Lightly lubricate all moving parts of the machine at the end of the season or every 25 operating hours.



*Do not allow grease or oil get on friction disc, friction plate or belts. Do not excessively oil the machine; extra oil may enter the traction drive and cause the traction drive belt to slip.*

- » When lubricating auger shaft, remove shear pins to apply oil inside the shaft and around spacers and flange bearings found at either end of the shaft.
- » Remove the wheels to apply grease the wheel shaft.

## SERVICE

### REPLACEMENT SHEAR PINS

A pair of replacement auger shear pins and clevis pins are included with your snow blower. Store them in a safe place until needed.

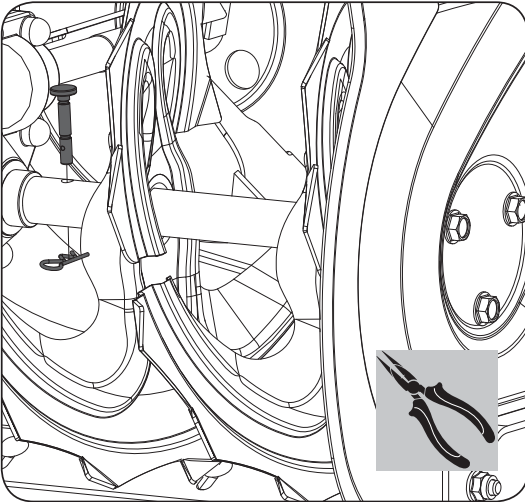


Figure 15



### SPARE ROLL PINS

The impeller is secured to the impeller shaft with roll pins.

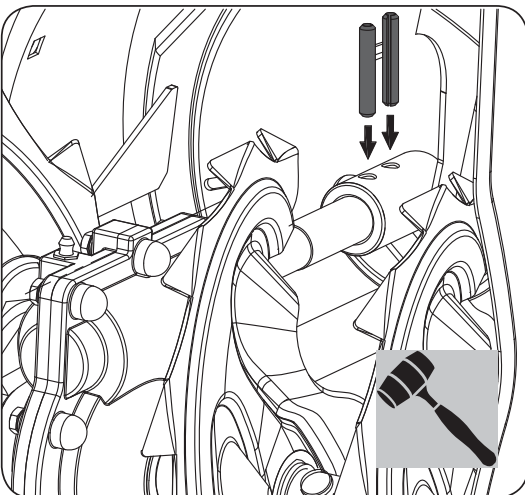


Figure 16



Two 6x37 roll pins for impeller are supplied as spare in the hardware kit. Store them in a safe place until needed.

### AUGER BELT REPLACEMENT

If the auger belt becomes worn, oil-soaked, or otherwise damaged, proceed as follows to replace the belt.

1. To prevent spillage drain all fluids, remove all fuel from tank by running engine until it stops. Remove the key to avoid unintended starting and allow unit to cool completely.
2. Remove the two screws that hold the belt cover in place and set the cover aside. (See **Figure 17a**)

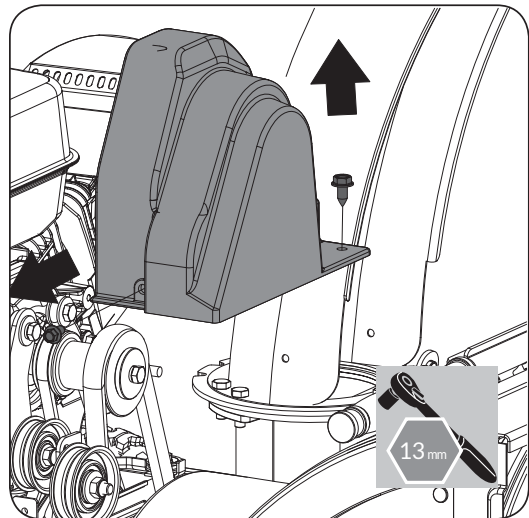


Figure 17a

3. Roll the auger belt off the engine pulley. (See **Figure 17b**)

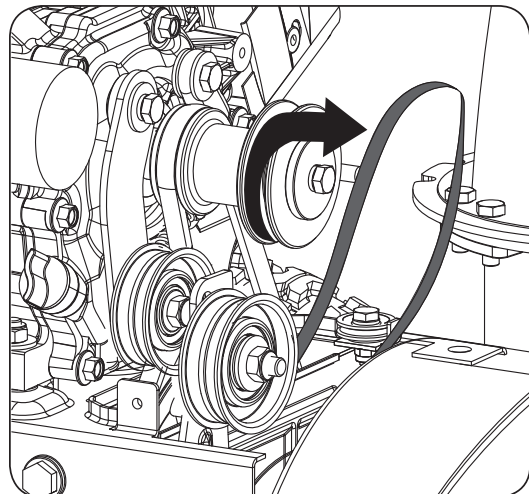
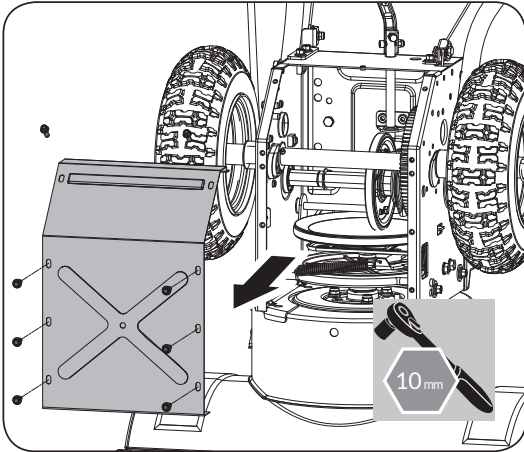


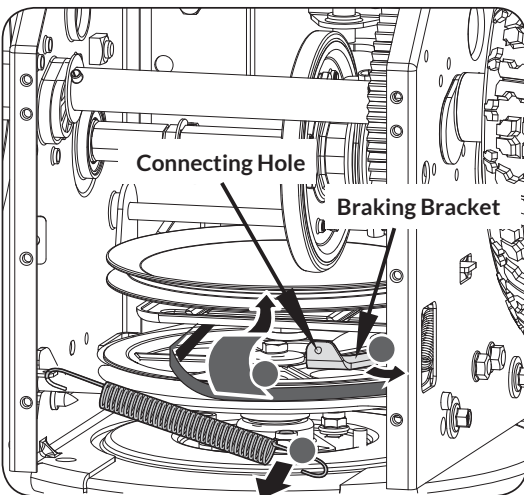
Figure 17b

4. Carefully pivot the snow blower up and forward so that it rests on the auger housing.
5. Remove the frame cover from the underside of the snow blower by removing the screws which secure the cover. (See **Figure 17c**)



**Figure 17c**

6. Release the spring from the connecting hole in the braking bracket. Move the braking bracket away from the belt. Remove the belt from around the auger pulley, and slip the belt between the support bracket and the auger pulley. (See **Figure 17d**)



**Figure 17d**

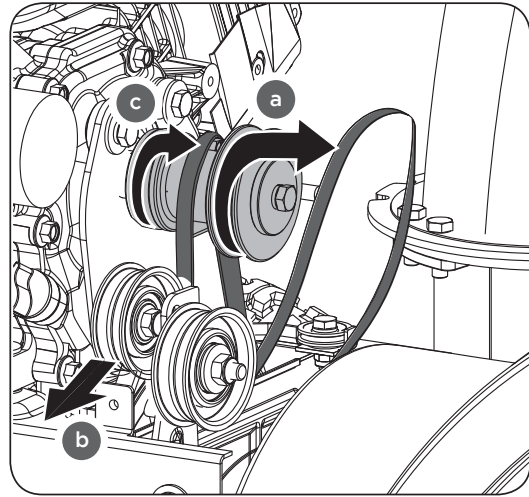
7. Replace the auger belt by following instructions in reverse order.

### DRIVE BELT REPLACEMENT

If the drive belt becomes worn, oil-soaked, or otherwise damaged, proceed as follows to replace the belt.

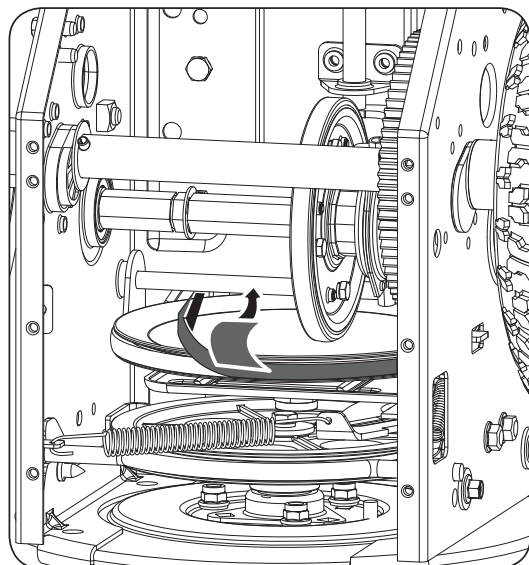
1. To prevent spillage, remove all fuel from tank by running engine until it stops. Remove the key to avoid unintended starting and allow unit to cool completely.
2. Remove the two screws that hold the belt cover in place and set the cover aside. (See **Figure 17a**)
3. Remove the belt as follows.
  - a. Roll the auger belt off the engine pulley. (See **Figure 17b**)

- b. Pivot the idle pulley toward the right to relieve tension.
- c. Lift the drive belt off engine pulley. (See **Figure 18a**)



**Figure 18a**

4. Carefully pivot the snow blower up and forward so that it rests on the auger housing.
5. Remove the frame cover from the underside of the snow blower by removing the screws which secure the cover. (See **Figure 17c**)
6. You must push down the friction wheel disc a bit by hand. Then slip the drive belt off the pulley and between friction wheel and friction wheel disc. (See **Figure 18b**)



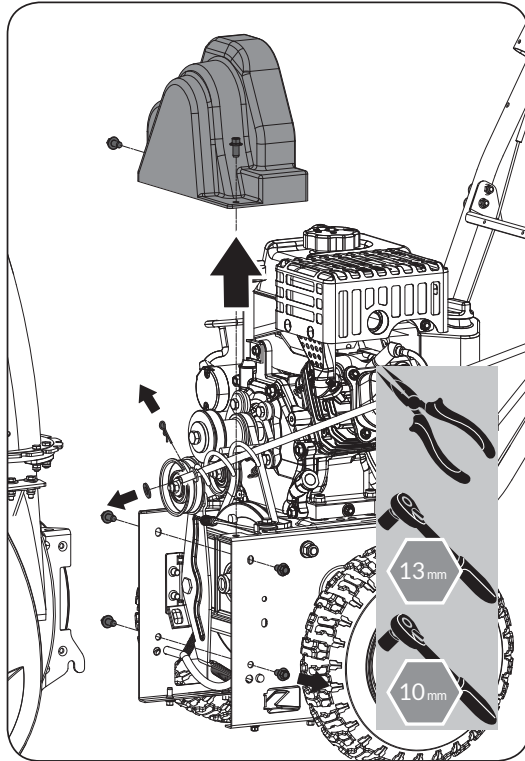
**Figure 18b**

7. Remove and replace belt in the reverse order.

» Holding down the drive clutch lever will ease reinstallation of the belt.

If an assistant is available, you can also separate the auger housing from the frame assembly to replace belts.

1. Shut off engine, remove key, disconnect spark plug wire and allow unit to cool completely.



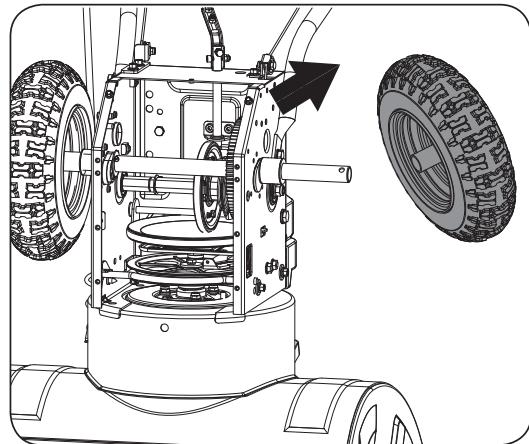
**Figure 18c**

2. Remove belt cover. (See **Figure 17a**)
3. Remove the clevis pin and washer from the directional chute control to remove it from the lower bracket.
4. Remove bottom cover to avoid bending it when tipping unit apart. (See **Figure 17c**)
5. Remove the screws securing auger housing to the frame (two on each side). Tip auger housing and frame. (See **Figure 18c**)
6. Replace auger belt or drive belt.
7. Tip auger housing and frame back together and secure with screws.
  - » Holding down the auger clutch lever will ease reconnection of the auger housing and frame.
8. Place belt(s) onto engine sheave(s).
9. Reinstall the directional chute control.

## FRICITION WHEEL REPLACEMENT

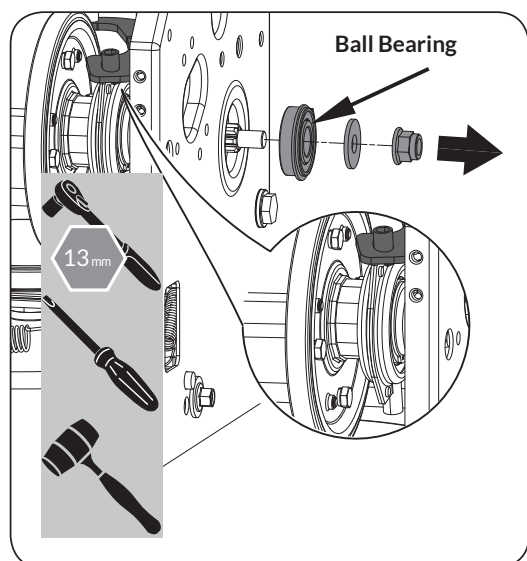
If the snow blower fails to drive with the drive clutch engaged, and performing the clutch control cable adjustment fails to correct the problem, the friction wheel may need to be replaced.

1. To prevent spillage drain all fluids, remove all fuel by rinning engine until it stops. Remove the key to avoid unintended starting and allow unit to cool completely.
2. Carefully pivot the snow blower up and forward so that it rests on the auger housing.
3. Remove the frame cover(s) from the underside of the snow blower by removing the screws which secure the cover(s). (See **Figure 17c**)
4. Remove the right-hand wheel by removing the axle lock pin. (See **Figure 19a**)



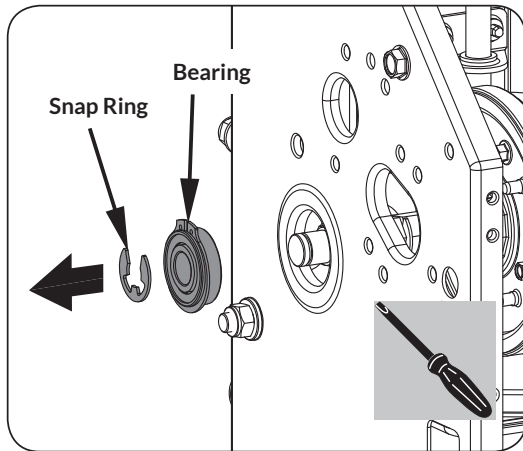
**Figure 19a**

5. Carefully remove the hex nut and washer which secures the hex shaft to the snow blower frame and lightly tap the shaft's end to dislodge the ball bearing from the right side of the frame. Be careful not to damage the threads on the shaft. (See **Figure 19b**)



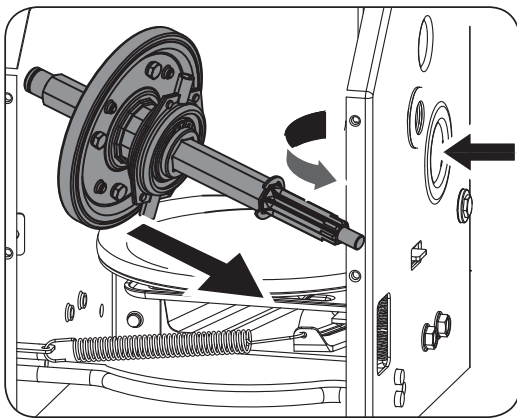
**Figure 19b**

- Remove the other bearing from the left side of the frame by removing the snap ring.



**Figure 19c**

- Carefully position the hex shaft downward and to the left
- Carefully sliding the friction wheel assembly off the shaft.

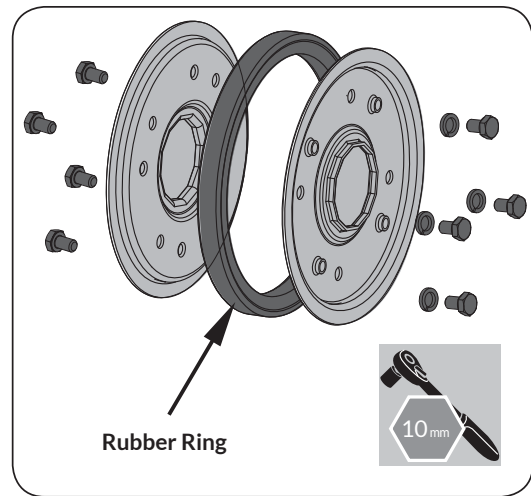


**Figure 19d**

- Follow the previous steps in reverse order to reassemble.

If you only want to replace the rubber ring, proceed as follows:

- Remove the eight screws which secure the friction wheel's side plates together.



**Figure 19e**

- Remove the rubber ring from between the plates.
- Reassemble the side plates with a new rubber ring.

When reassembling the friction wheel assembly, make sure that rubber ring is centered and seated properly between the side plates. Tighten each screw only one rotation before turning the wheel clockwise and proceeding with the next screw on the other side of the wheel. Repeat this process several times to ensure the plates are secured with equal force between 90N.m(6 ft-lbs) and 130N.m(9 ft-lbs).

- Slide the friction wheel assembly back onto the hex shaft. Make sure the shift lever pin is in place in the bearing housing. Follow the steps above in reverse order to reassemble components.

## STORAGE



Refer to the Engine Manual for information on storing your engine.

At the end of the season or if the snow blower will not be used for 30 days or longer, follow the storage instructions below.

- Run the engine until the fuel lines and carburetor are empty and it stops due to lack of fuel.
- Remove the safety ignition key and allow the engine to cool.
- Lubricate the machine as instructed.
- Clean the exterior of the engine and the snow blower thoroughly.
- Touch up all rusted or chipped paint surfaces; sand affected areas before painting, and use a rust preventative to prevent the metal parts from rusting.
- Tighten all loose screws, bolts, and locknuts. Repair or replace any damaged parts.
- Cover the machine and store it in a clean, dry place out of the reach of children.



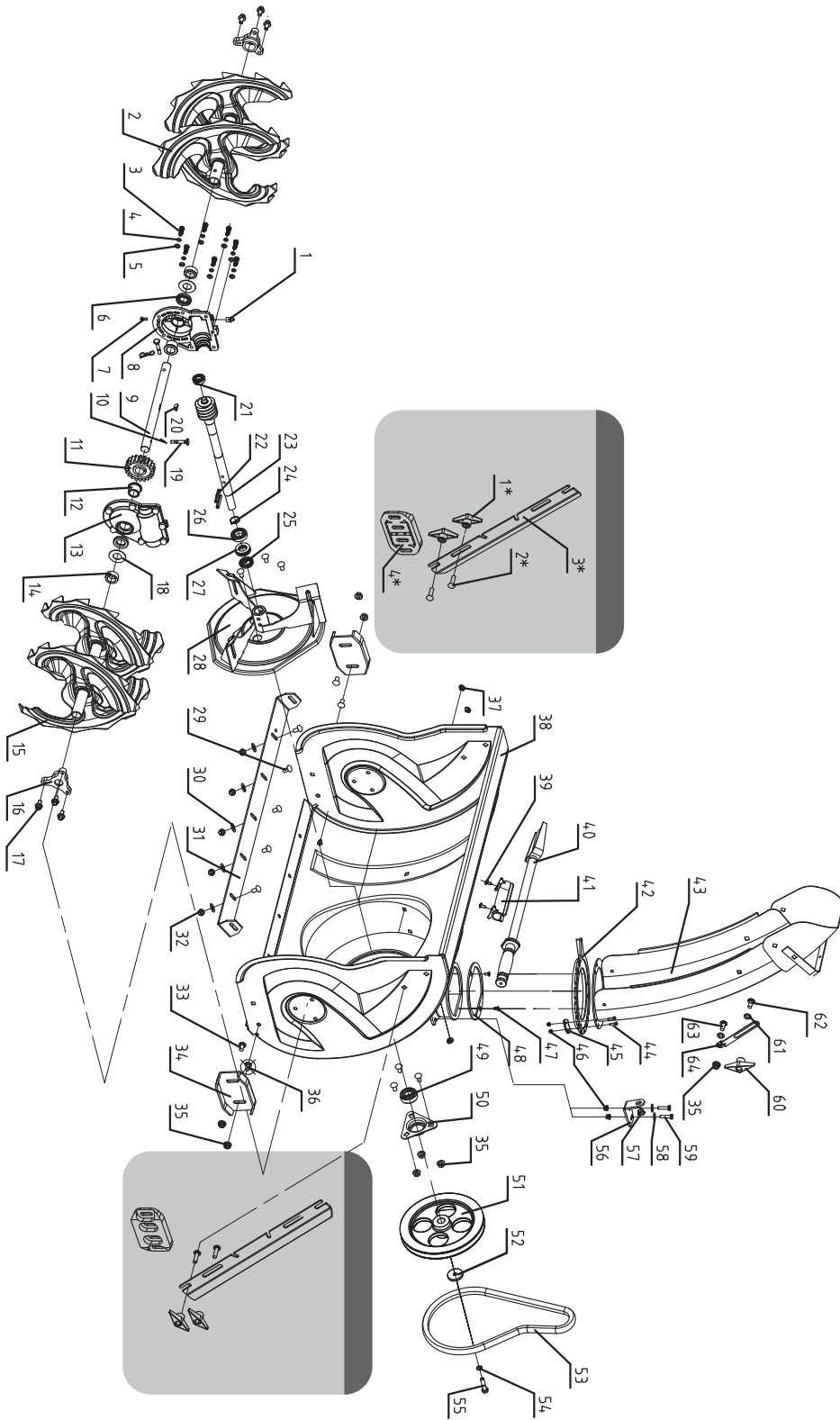
## TROUBLESHOOTING

Problem	Cause	Remedy
Electric starter does not turn (on models so equipped)	<ol style="list-style-type: none"> <li>1. Extension cord not connected</li> <li>2. The extension cord is worn, corroded, or damaged</li> <li>3. The power outlet is not energized</li> </ol>	<ol style="list-style-type: none"> <li>1. Connect the extension cord to the outlet and/or the machine</li> <li>2. Replace the extension cord</li> <li>3. Have a qualified electrician energize the outlet</li> </ol>
Engine fails to start	<ol style="list-style-type: none"> <li>1. Choke not in CHOKE position</li> <li>2. Engine not primed</li> <li>3. Engine is flooded</li> <li>4. Fuel shut-off valve closed</li> <li>5. Throttle in STOP position or RUN/STOP switch is STOP</li> <li>6. Spark plug wire loose or disconnected</li> <li>7. Fuel tank empty or stale fuel</li> <li>8. Faulty spark plug</li> <li>9. Safety ignition key is not inserted</li> <li>10. The engine oil level in the engine crankcase is too low or too high</li> </ol>	<ol style="list-style-type: none"> <li>1. Move choke to CHOKE position</li> <li>2. Prime engine as instructed in this manual</li> <li>3. Wait a few minutes before restarting, do not prime</li> <li>4. Open fuel shut-off valve</li> <li>5. Move throttle to FAST position or RUN/STOP switch to RUN Position</li> <li>6. Connect or tighten spark plug wire</li> <li>7. Fill tank with clean, fresh gasoline and stabilizer</li> <li>8. Clean, adjust gap, or replace</li> <li>9. Insert safety ignition key</li> <li>10. Add or drain oil to adjust the oil level in the engine crankcase</li> </ol>
Engine idles or runs roughly	<ol style="list-style-type: none"> <li>1. Engine running on CHOKE</li> <li>2. Fuel tank is nearly empty or stale fuel</li> <li>3. Contaminated fuel supply</li> <li>4. Carburetor out of adjustment</li> <li>5. Engine over-governed</li> <li>6. The fuel shutoff valve is not completely open or blockage in fuel line</li> <li>7. Spark plug wire loose</li> <li>8. Faulty spark plug</li> <li>9. The engine oil level in the engine crankcase is too low or too high</li> </ol>	<ol style="list-style-type: none"> <li>1. Move choke lever to RUN position</li> <li>2. Fill tank with clean, fresh gasoline</li> <li>3. Replace with clean fuel</li> <li>4. Contact a qualified repair personnel</li> <li>5. Contact a qualified repair personnel</li> <li>6. Open the fuel shutoff valve or clean fuel line</li> <li>7. Tighten spark plug wire</li> <li>8. Clean, adjust gap, or replace</li> <li>9. Add or drain oil to adjust the oil level in the engine crankcase</li> </ol>
The engine overheats	Carburetor not adjusted properly	Contact a qualified repair personnel

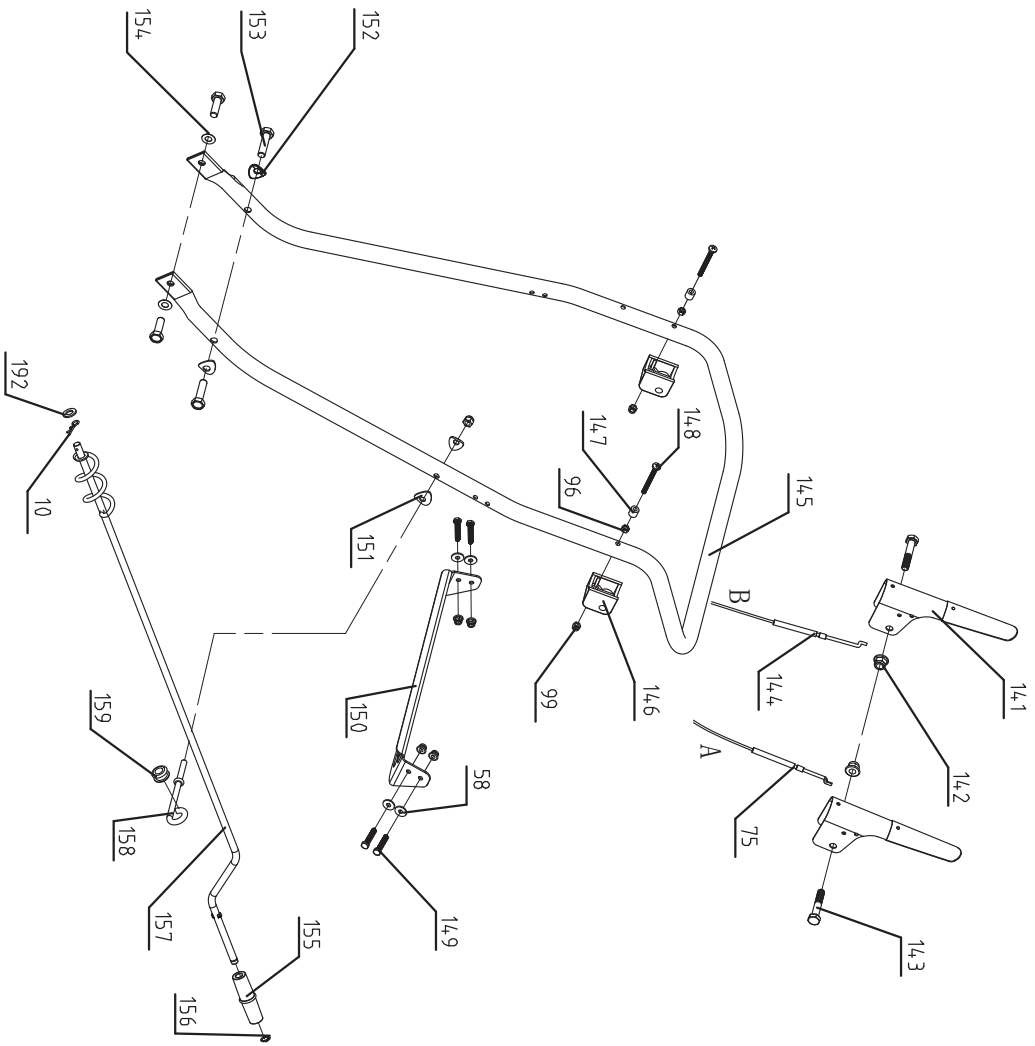
Excessive vibration	Loose parts or damaged parts	Tighten all fasteners or replace damaged parts
Loss of power	<ol style="list-style-type: none"> <li>1. Spark plug wire loose</li> <li>2. Gas gap vent hole plugged</li> <li>3. Dirty or clogged muffler</li> </ol>	<ol style="list-style-type: none"> <li>1. Tighten spark plug wire</li> <li>2. Clean or replace fuel cap</li> <li>3. Clean or replace muffler</li> </ol>
Loss of traction drive	<ol style="list-style-type: none"> <li>1. Drive control cable not adjusted properly</li> <li>2. Drive belt loose or damaged</li> <li>3. Friction wheel worn</li> </ol>	<ol style="list-style-type: none"> <li>1. Adjust drive control cable</li> <li>2. Replace drive belt</li> <li>3. Replace friction wheel</li> </ol>
Loss of snow discharge or slowing of snow discharge	<ol style="list-style-type: none"> <li>1. Discharge chute clogged</li> <li>2. Augers or impeller jammed</li> <li>3. Auger control cable not adjusted properly</li> <li>4. Auger belt loose or damaged</li> <li>5. Shear pin(s) sheared</li> <li>6. Throttle not in FAST position when throwing snow</li> <li>7. Moving too fast to clear the snow</li> <li>8. Throwing too much snow</li> <li>9. Trying to remove extremely heavy or wet snow</li> <li>10. Auger is frozen in place</li> </ol>	<ol style="list-style-type: none"> <li>1. Unclog discharge chute</li> <li>2. Remove debris or foreign object from augers or impeller</li> <li>3. Adjust auger control cable</li> <li>4. Replace auger belt</li> <li>5. Replace with new shear pin(s)</li> <li>6. Move throttle to FAST position</li> <li>7. Shift into a lower gear</li> <li>8. Reduce speed and width of swath</li> <li>9. Do not overload with extremely heavy or wet snow</li> <li>10. Move unit to a warm place to thaw</li> </ol>
Discharge chute either does not lock into place or does not move	<ol style="list-style-type: none"> <li>1. The discharge chute control not adjusted properly</li> <li>2. Chute assembly incorrectly</li> </ol>	<ol style="list-style-type: none"> <li>1. Adjust the discharge chute control</li> <li>2. Disassemble chute control and reassemble as instructed in this manual</li> </ol>
Machine does not properly clear the snow of the surface	<ol style="list-style-type: none"> <li>1. The skid shoes and/or scraper blade not adjusted properly</li> <li>2. The pressure in the tires not equal</li> </ol>	<ol style="list-style-type: none"> <li>1. Adjust the skid shoes and/or the scraper blade</li> <li>2. Check and adjust the pressure in one or both tires</li> </ol>

# PARTS DIAGRAM

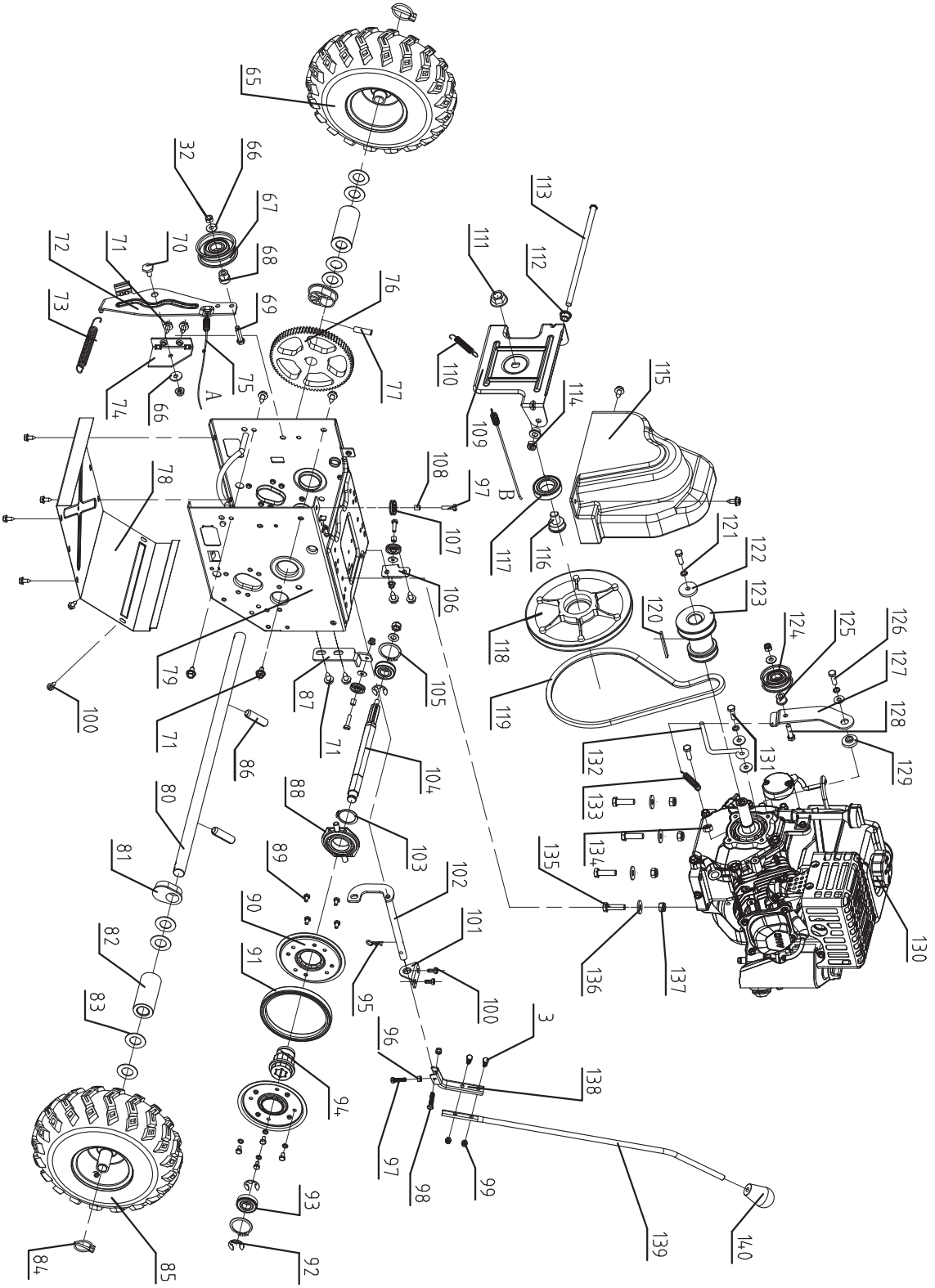
## MAIN MACHINE



# HANDLEBARS



GEARBOX



## PARTS LIST

No.	Description	Qty	No.	Description	Qty	No.	Description	Qty
1	Oil Seal M10x1	1	37	Plug	5	73	Extension Spring	1
2	Spiral Assembly-Right	1	38	Auger Housing Assy.	1	74	Auger Idler Mounting Bracket	1
3	FT Bolt M6x20	8	39	Screw ST5.5x13	3	75	Friction Wheel Cable	1
4	Spring Washer 6	15	40	Chute Clean-Out Tool	1	76	Big Gear	1
5	Flat Washer 6	10	41	Clean-Out Tool Mounting Bracket	1	77	Pin A6x35	1
6	Seal B20x35x7	2	42	Chute Crank Flange	1	78	Frame Cover	1
7	Screw M5x10	1	43	Discharge Chute	1	79	Gearbox Main Frame	1
8	Auger Gearcase Housing-Right	1	44	FT Bolt M6x30	6	80	Wheel Shaft	1
9	Auger Shaft	1	45	Chute Flange Keeper	3	81	Shaft Bushing	2
10	Clevis Pin 1.8	5	46	Flange Lock Nut M6	12	82	Shaft Spacer	2
11	Worm Wheel	1	47	Screw M5x6	2	83	Wahser	3
12	Shaft Sleeve	2	48	Discharge Chute Washer	1	84	Lock Pin 8	2
13	Auger Gearcase Housing-Left	1	49	Ball Bearing 60203-2RS	1	85	Wheel	1
14	Washer	2	50	Bearing Housing	1	86	Pin 6x36	2
15	Spiral Assembly-Left	1	51	Auger Pulley	1	87	Auger Cable Holder 1	1
16	Bearing Box	2	52	Big Flat Washer 8	2	88	Shift Arm	1
17	Screw ST8x16	6	53	Auger Belt 4LXP960	1	89	FT Bolt M6x10	8
18	Big Washer	2	54	Spring Washer 8	3	90	Friction Wheel Side Plate	2
19	Shear Pin	2	55	Bolt M8x25	1	91	Rubber Ring	1
20	Half Round Key 5x7.5x19	1	56	Chute Crank Bracket	1	92	Snap Ring 15	2
21	Ball Bearing 6001-2RS	1	57	Bushing	1	93	Ball Bearing 60203-2RSN	2
22	Roll Pin 6x37	2	58	Flat Washer 6	8	94	Friction Wheel Hub	1
23	Impeller Shaft	1	59	FT Bolt M6x20	2	95	Clevis Pin 2	1
24	Washer	1	60	Handle Knob Assembly	1	96	Nut M6	3
25	Seal B20x35x7	1	61	Lock Washer	2	97	FT Bolt M6x25	4
26	Ball Bearing 61904-2RS	1	62	Bolt M8x35	1	98	Bolt M6x30	1
27	Thrust Bearing 51104	1	63	Bolt M8x20	1	99	Lock Nut M6	3
28	Impeller Assembly	1	64	Chute Linkage Plate	1	100	Screw M6x16	10
29	Bolt M8x16	5	65	Wheel	1	101	Fork Bracket	1
30	Flat Washer 8	5	66	Flat Washer 8	5	102	Fork Assembly	1
31	Shave Plate	1	67	Auger Idler	1	103	Circlip 35	1
32	Lock Nut M8	9	68	Spacer	1	104	Hex Shaft	1
33	Bolt M8x20	5	69	FT Bolt M8x35	1	105	Circlip 40	2
34	Skid Shoe (Metal)	2	70	Pivot Bolt	1	106	Auger Cable Holder 2	1
35	Hex. Flange Nut M8	9	71	Screw M8x16	12	107	Cable Roller	3
36	Bolt M8x25	2	72	Auger Idler Bracket	1	108	Roller Bushing	3

No.	Description	Qty
109	Driven Pulley Bracket	1
110	Friction Wheel Retaining Spring	1
111	Flange Lock Nut M16x1.5	1
112	Locating Knot	2
113	Locating Shaft	1
114	Flange Lock Nut M10	1
115	Engine Belt Cover	1
116	Driven Pulley Hub	1
117	Ball Bearing 6006-2RS	1
118	Engine Pulley	1
119	Drive Belt	1
120	Key 6X6X45	1
121	Spring Washer 10	1
122	Washer	1
123	Belt Pulley	1
124	Drive Clutch Idler	1
125	Bushing	1
126	Bolt 5/16-24unf	1
127	Drive Clutch Idler Bracket	1
128	FT Bolt M8x30	1
129	Spacer	1
130	Engine	1

No.	Description	Qty
131	Bolt 5/16-24unf	2
132	Belt Blocker	1
133	Extension Spring	1
134	Jam Nut 5/16-24unf	1
135	FT Bolt M8x35	4
136	Flat Washer 10	6
137	Flange Lock Nut M8	4
138	Spring Clip	1
139	Shift Rod	1
140	Operating Handle	1
141	Handle	2
142	Flange Lock Nut M10	2
143	Screw M10x55	2
144	Chute Adjustable Cable	1
145	Rail Handle	1
146	Handle Base	2
147	Handle Locate Jacket	2
148	Screw M6x60	2
149	Screw M6x40	4
150	Control Panel	1
151	Arc Washer 8	2
152	Arc Washer 10	2

No.	Description	Qty
153	FT Bolt M10x40	2
154	FT Bolt M10x20	2
155	Directional Chute Control Lever Knob	1
156	Circlip 10	1
157	Directional Chute Control Lever	1
158	Chute Bracket	1
159	Rubber Spacer	1
160	Washer 10	1

### OPTIONAL DRIFT CUTTERS

No.	Description	Qty
1*	Handle Knob Assembly	4
2*	Bolt M8x25	4
3*	Drift Cutter	2

### OPTIONAL SKID SHOES

No.	Description	Qty
4*	Plastic Skid Shoe	2

*Tame the Great Outdoors™*

