

# Install Guide CT80

# Radio Thermostat

Radio Thermostat Company of America

## Caution

- The thermostat is a precise instrument, handle with care.
- Turn off electricity to the HVAC system before installing or servicing thermostat or any part of the system.
- Do not turn electricity back on until work is completed.
- Do not short (jumper) across electric terminals at the control on the furnace or air conditioner to test the system. This may damage the thermostat.
- All wiring must conform to local codes and ordinances.
- This thermostat is designed for use with 24VAC and millivolt systems (with a separate 24VAC power adapter).
- The thermostat relay load should be limited to 1.0 amp; higher amperage may cause damage to the thermostat.

## Caution

To avoid electrical shock and to prevent damage to the furnace, air conditioner, and thermostat, disconnect the power supply before beginning work. This can be done at the circuit breaker, or at the HVAC system.

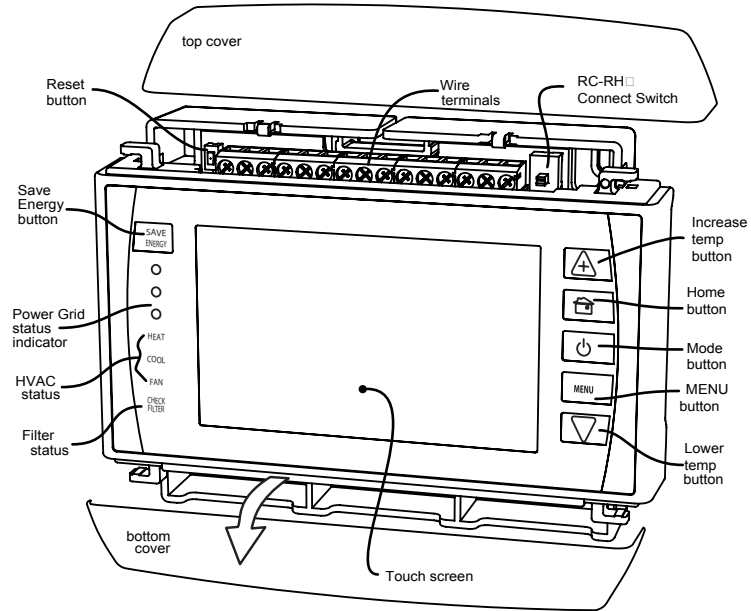

## TOOLS

You will need a small Phillips screwdriver and a drill with 3/16-in. (4.8mm) bit for wall mounts.

## LOCATION

Replacement installations - mount the CT80 in place of the thermostat. You must have a “C” wire or other 24VAC power available at the CT80 location. A new location will require moving your wiring.

New installations and for relocating the CT80 - follow the guidelines listed below:

- Locate the thermostat on an inside wall, about 5 ft. (1.5m) above the floor, and in a room that is used often.
- Do not install it where there are unusual heating conditions, such as: in direct sunlight; near a lamp, radio, television, radiator register, fireplace; near hot water pipes in a wall; or near a stove on the other side of a wall.
- Do not locate in unusual cooling conditions, such as: on a wall separating an unheated room; or in a draft from a stairwell, door, or window.
- Do not locate in a damp area. This can lead to corrosion that will shorten thermostat life.
- Do not locate where air circulation is poor, such as: in a corner, an alcove; behind an open door.
- Do not install the CT80 until all construction and painting has been completed.
- This thermostat does not require leveling.

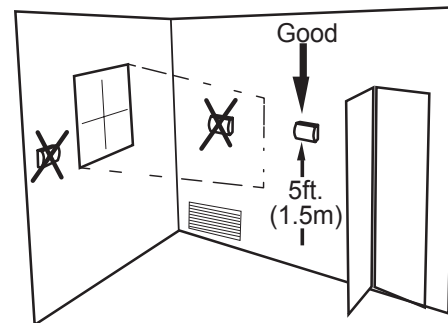

## REMOVE OLD UNIT

- ⚠ Switch OFF electricity to the furnace and air conditioner; then follow these steps.
- Remove cover from old thermostat. Most are snap-on types and simply pull off. Some have locking screws on the side or front. These must be loosened. DO NOT remove wires. Note the letters printed near the terminals. Attach labels (enclosed) to each wire for identification.

### ⚠ Caution

Read instructions carefully before removing any wiring from existing thermostat. Wires must be labeled before they are removed. **THERE IS NO STANDARD COLOR CODE.** When removing wires from their terminals, ignore the color of the wires and **LABEL THEM** by the terminal where they were screwed.

- Label the wires one at a time. You must label all the wires before you proceed. With all wires labeled, remove them from the old unit.
- Make sure the wires do not fall back inside the wall. You can wind them around a pencil to keep them from falling.
- Loosen all screws on the old thermostat and remove it from the wall.

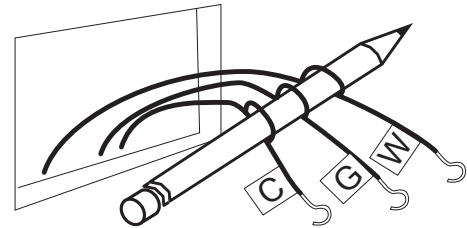

## What wires do you have?

Make sure your wires are labeled. This may require you to find the 'other end' connection for each wire on your heating or air conditioning equipment and read the label there. Refer to the Wire Reference page at end of install section for better understanding of wire labels from different HVAC system makers.

**⚠ IMPORTANT:** The CT80 requires constant 24VAC power from the HVAC system's "C wire". If you do not have a C wire you can run a new wire from the HVAC or use a standard 24VAC 100mA or greater wall transformer.

**⚠ IMPORTANT:** If you have both RH and RC wires you need to move the RC/RH switch to the UP position which separates these terminals.

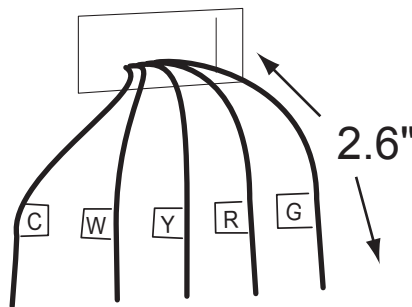

## Prepare Wires

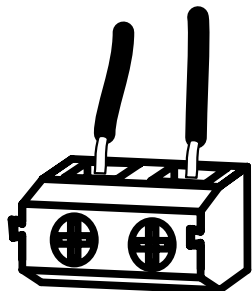

Wire Terminals

Please follow these guidelines for safe and secure wire connections:

- You will need at least 2.6" of wire for each of your connections to the CT80.
- If you do not have enough wire, splice additional wire to allow enough slack.
- Terminals accept wires from 16-22awg.
- Fan out wires below the hole as shown.
- Remove insulation 1/8" from the tip of each wire.

## Find the step-by-step diagram for your system

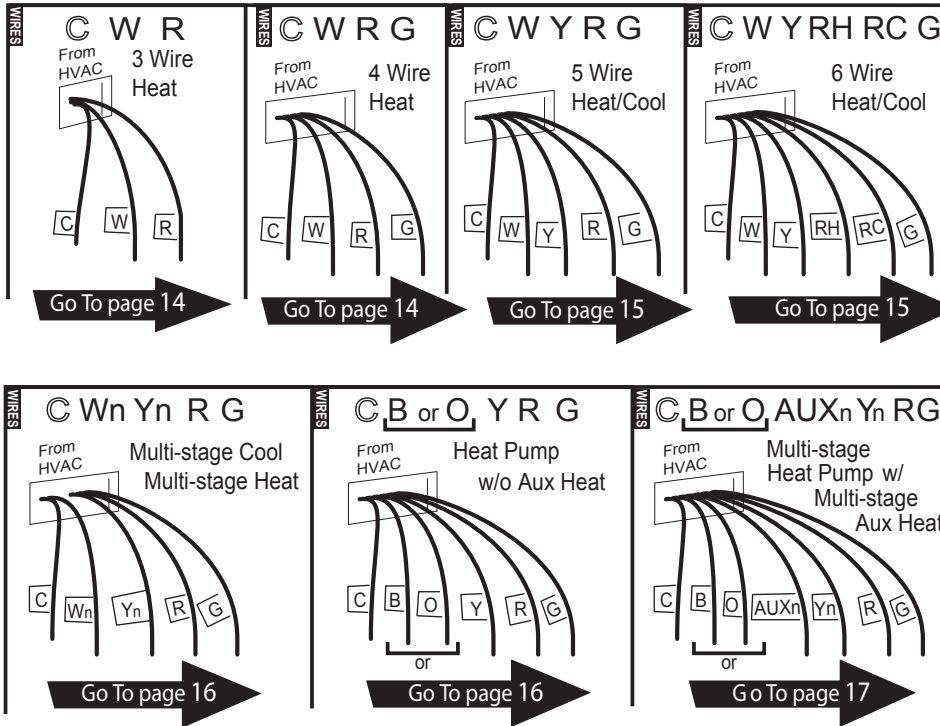

- Select the reference page with your wiring diagram and set-up information below.

- The C-wire is required to operate your CT80. If you do not have a C wire you will need to provide an alternate source of 24VAC power to the unit.

- If your combination of wires is shown here, you can use the wiring table at the end of the install section to determine your connections, or contact customer support for help.

- When handling, take care not to damage the labels for each wire.

- “Fan out” wires as illustrated with CT80 below the wall opening. As in the example: fan out the wires so that the C wire is above the C terminal, the W above the W. This allows the CT80 to fit snug to the wall.



## Caution

Do not allow wires to touch each other or parts on thermostat.

- Wires will position behind the CT80 and up over the terminal area.
- Do not bunch wires behind the CT80. Feed any slack back into the wall opening.

## Connect Your Wires

- Connect labeled wires only to a terminal with the same letter label.
- Insert the wire in the terminal well and tighten the screw securely.

NOTE: If you wish you can mount the CT80 to the wall first, and then connect the wires.

- The CT80 can be externally powered with a power source rated for 24V, AC or DC, at 300ma or greater. If used, connect to the C and RH terminals (no polarity).

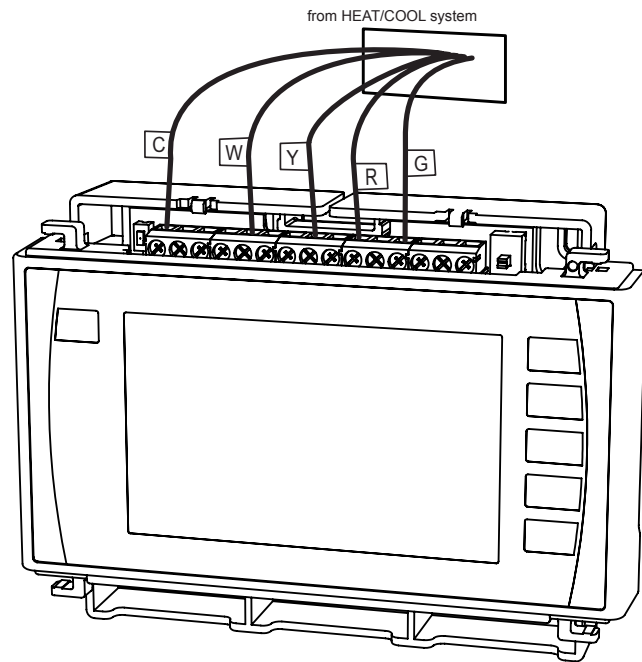

## Mount the CT80 to Wall

1. Hold the CT80 against the wall, with the wires coming over the top; above terminal block. The CT80 will cover the hole in the wall.
2. Position CT80 for best appearance.
3. Attach the CT80 to the wall with the screws provided.
4. If you are mounting the CT80 to sheet rock or if you are using the old mounting holes, use the plastic anchors provided.
5. Mark first and drill a 3/16-in.(4.8mm) hole for the insert at each screw location, then mount the unit.

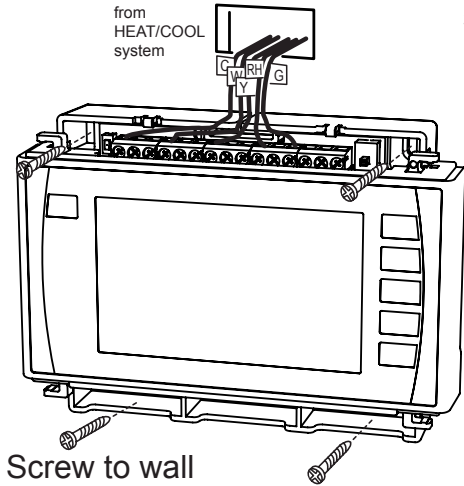

Place wires like this inside wire groove

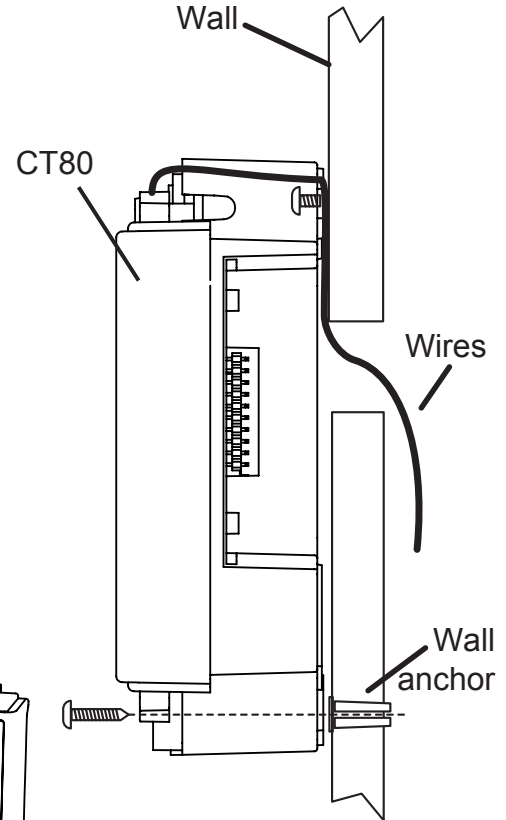
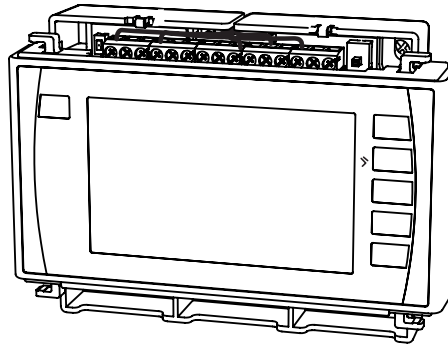

## Turn ON Power

With all the wires connected (including the C wire), it is time to turn the AC power back on. Do this at the breaker you used to switch it off. The CT80 will power-up in the control OFF mode. Your CT80 is not configured to operate your HVAC system yet. You must now use the menu driven HVAC SET-UP function.

## HVAC setup

**⚠ IMPORTANT:** Make sure the CT80 is powered up and is in the OFF mode before set-up. (To turn your thermostat off, press the  Mode button in the middle of the control bar to the right of the display and touch OFF). Heat and Cool systems must be configured separately (except with Heat Pumps).

**The CT80 uses an easy to use interview to determine the proper setup for your HVAC system. You must know what type of HVAC system you have before answering the interview questions. If you are not sure, go to the HVAC unit and determine the make and model then get a manual for the system.**

**If you are experienced with HVAC systems, you can use the FASTSET single page setup to set all functions on one screen.**

**Interview setup - You will need to be able to answer these questions -**

“Do you want to configure HEAT or COOL? (Touch one)

Do you have a NORMAL heating system or a HEAT PUMP system?



Is your heat GAS/OIL or ELECTRIC?

Is your system multi-stage? No 2 Stages 3 Stages

Thank you, your thermostat is configured to control your HEATING.

Configure COOL?

How many stages of A/C do you have? 1 stage 2 stage

Thank you, your thermostat is configured to control your COOLing.”

### **If you have a HEAT PUMP system you will be asked these questions -**

“Is your heat pump multi-stage? 1 stage 2 stage

Do you have auxiliary heat? YES or NO

(if yes) What kind of aux heat do you have? ELEC or GAS/OIL

How many stages of aux heat do you have? 1 stage 2 stage 3stage

(Maximum of 5 stages total pump and aux)

Thank you, your thermostat is configured to control your heating and cooling.”

When you have completed set-up completing interview go to pg 11 and test your installation.

### **FASTSET for NORMAL systems** (not a heat pump):

1. Press the purple **MENU** button on the control bar and then touch **HVAC SET-UP**.
2. Touch to highlight **HEAT** in the upper left corner of the display.
3. Touch to highlight **NORMAL**.

HVAC SET-UP	12:30pm WED 7 7'
HEAT or COOL	STAGES
NORMAL	
HEAT PUMP	[1]
AUXILIARY	[NONE]
AUX ELECT or GAS-OIL	
FAN CONTROL TSTAT	
<INTERVIEW>	BACK>

4. Select the appropriate number of stages for your heating system (from 1 to 3) by touching the number of **STAGES** (in brackets) to highlight, and using the +/- buttons to increase or decrease.
5. Touch the appropriate **FAN CONTROL** setting.  
Select **HVAC** if your heating system controls the fan (appropriate for most gas, oil, propane and similar furnaces).  
Select **TSTAT** if you want the thermostat to control the fan (for most electric heating systems).
6. Go on to configure **COOL** or press **HOME** to return to the Home screen.

### **FASTSET for NORMAL A/C cooling systems:**

1. Press **MENU** and then touch **HVAC SET-UP**.
2. Touch and highlight **COOL** in the upper left corner of the display.
3. Select the number of stages of compression for your cooling system (1 or 2) by touching the number of **STAGES** and using +/- buttons to increase or decrease.
4. Touch to select the appropriate **FAN CONTROL** setting **HVAC** or **TSTAT**.  
NOTE: Most cooling systems require that the thermostat **TSTAT** control the fan.
5. Press **HOME** to return to the Home screen.

### **SET-UP for HEAT PUMP systems:**

1. Press **MENU** and then touch **HVAC SET-UP**.
2. Touch **HEAT** in the upper left corner of the display.
3. Touch **HEAT PUMP**.
4. Select the number of stages of compression for your heat pump system (1 or 2) by touching the number of **STAGES**, and using the +/- buttons to increase or decrease (same for **HEAT** and **COOL**).  
NOTE: Most heat pump systems have one stage of compression.

5. If you have AUXILIARY heat, touch the number of stages (default is [NONE] ) use the +/- buttons to select 1-3 stages. (NOTE: The CT80 controls a maximum of 5 stages total between pump and AUX.)

6. (If you have AUX) Select the type of auxiliary heat that you have - Electric or Gas-Oil.  
NOTE: Most heat pump systems have electric heat strips for auxiliary heat.

7. Fan Control is set by the CT80 (tstat) for heat pumps.

8. Press HOME button to return to the Home screen.

NOTE: For heat pump system your cooling is already configured since the heat pump unit provides both heating and cooling.

## Test Installation

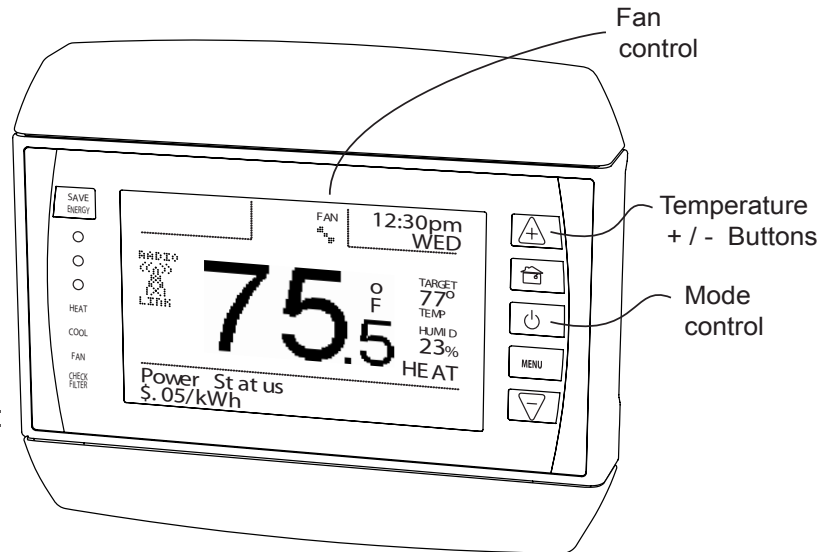

Follow these procedures to verify you have correctly installed the CT80.

**TO CHECK FAN** (If you connected the G wire):  
Touch the fan icon and turn the fan **ON**.  
Verify that air is blowing from the system.  
Press the fan icon again and return to **AUTO**.





## Test Installation cont.

To check **HEAT** mode:

1. Press the mode control  and select HEAT.
2. Press the **+** button to raise the target temp to 90°F. Allow the system 2 minutes to respond.
3. Verify that heat is blowing from the system.
4. Return mode control  to OFF (leave OFF for 4 minutes before checking COOL).

To check **COOL** mode (do not operate AC if outside temp is below 65°F):

1. Press the  mode control and select **COOL**.
2. Press the blue **-** button to lower the cool target temperature to 50°F.  
Allow the system 5 minutes to respond.
3. Verify that cool air is blowing from the system.
4. Return  mode to OFF

**Congratulations, you have successfully installed your unit. Please proceed to the OPERATING Guide to initialize the CT80.**

**⚠ IMPORTANT:** After you have labeled and connected your wires, and followed the correct HVAC set-up, if these check procedures do not operate your system more info is available on our website at [www.radiothermostat.com](http://www.radiothermostat.com) or 877-602-5028.

**STATEMENT OF USE** - This thermostat can be used with all 24VAC and millivolt (24VAC external power) heating and cooling systems. It cannot be used with line voltage systems. This thermostat is digital and your desired heat or cool temperatures can easily be set on the large touch screen with the +/- buttons. A minimum 4 minute off time protects heating and cooling compressors from damage. This thermostat uses a new technique called sequential staging for more comfort with faster reaction to requested temperature changes.

### **24VAC is Required -**

This thermostat can run on the HVAC system's 24VAC common "C" wire or an external adapter 12V to 24V AC or DC connected to the C and RH (no polarity). The 24VAC "C" wire is the other side of the 24VAC heating transformer and can be found where the other thermostat wires connect at the wall or at the furnace. **Do not** use the common or ground side of the line voltage.

## Step-by-step wiring diagrams

### 3 Wire Heat GAS MILLIVOLT or 24VAC system

STEP 1 - Connect the R (or RH) wire to the RH terminal.

This connects the heat power.

STEP 2 - Connect the W wire to the W terminal.

This connects the heat.

STEP 3 - Connect the C wire to the C terminal.

Your heater is now connected to the CT80.

← Please Go To Page 6

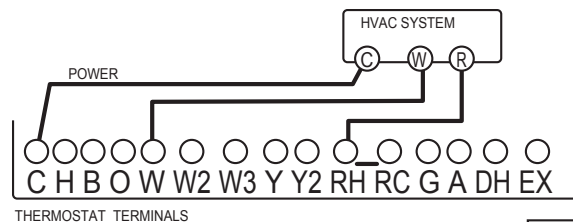

RC and RH  
connected

### 4 Wire Heat

STEP 1 - Connect the R (or RH) wire to the RH terminal. This connects the heat power.

STEP 2 - Connect the W wire to the W terminal.

This connects the heat.

STEP 3 - Connect the G wire to the G terminal on the thermostat. This connects the fan.

STEP 4 - Connect the C wire to the C terminal.

Your system is now connected to the CT80.

← Please Go To Page 6

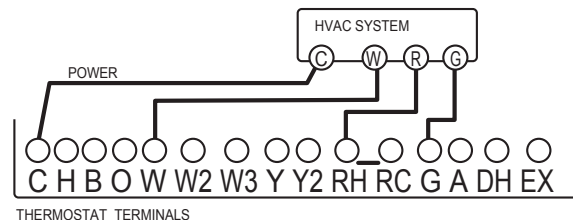

RC and RH  
connected

**5 Wire Heat/Cool****5 Wire Heat/Cool**

STEP 1 - Connect the W wire to the W terminal.

This connects the heat.

STEP 2 - Connect the Y wire to the Y terminal.

This connects the cooling compressor.

STEP 3 - Connect the R (or RH) wire to the RH terminal. This connects the power.

STEP 4 - Connect the G wire to the G terminal on the thermostat. This connects the fan.

STEP 5 - Connect the C wire to the C terminal.

Your HVAC system is now connected to the CT80.

← Please Go To Page 6

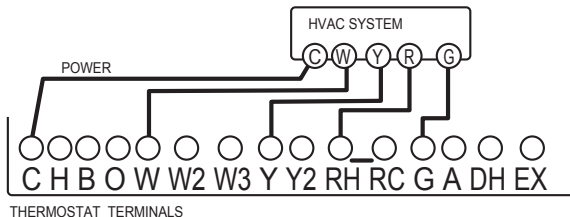

RC and RH  
connected

**6 Wire HEAT/Cool****6 Wire HEAT/Cool**

STEP 1 - Connect the W wire to the W terminal. This connects the heat.

STEP 2 - Connect the Y wire to the Y terminal. This connects to the cooling compressor.

STEP 3 - Disconnect the RC and RC terminals by placing the RC-RH switch in the UP position.

STEP 4 - Connect the RH wire to the RH and the RC wire to the RC terminals. This connects power.

STEP 5 - Connect the G wire to the G terminal. This connects the fan.

STEP 6 - Connect the C wire to the C terminal.

Your HVAC system is now connected to the CT80.

← Please Go To Page 6

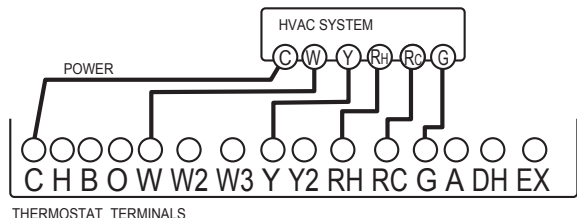

RC and RH  
disconnected

**Wires** C Wn Yn RG

**Multi-stage Heat and Multi-stage Cool**

The CT80 can handle up to 3 stages of HEAT and 2 stages of COOL.

STEP 1 - Connect the W, W2 and W3 wires to the W terminals. This connects the stages of HEAT.

STEP 2 - Connect the Y and Y2 wires to the Y terminals. This connects the stages of COOL.

STEP 3 - STEP 5 - Connect the R (or RH) wire to the RH terminal. This connects the power.

STEP 4 - Connect the G wire to the G terminal. This connects the fan.

STEP 5 - Connect the C wire to the C terminal.

Your HVAC system is now connected to the CT80.

← Please Go To Page 6

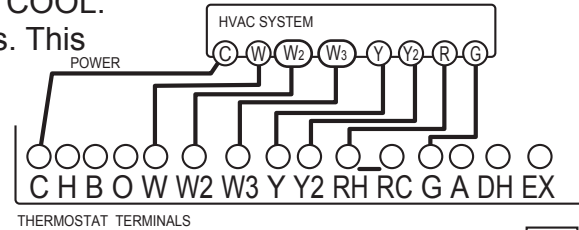

RC and RH connected

**Wires** C B or O Yn RG

**Heat Pump (heat/cool) without Auxiliary Heat**

STEP 1 - Connect O wire to the O terminal or B wire to the B. This connects the change-over valve. If you have both O and B - connect only the O wire to the O terminal and DO NOT connect B to B terminal (see wire reference under Trane for B wire terminal).

STEP 2 - Connect the Y wire(s) to the Y terminal(s). This connects the compressor (stages).

STEP 3 - Connect the R (or RH) wire to RH. This connects the power.

STEP 4 - Connect the G wire to the G. This connects the fan.

STEP 5 - Connect the C wire to the C terminal.

Your HVAC system is now connected to the CT80.

← Please Go To Page 6

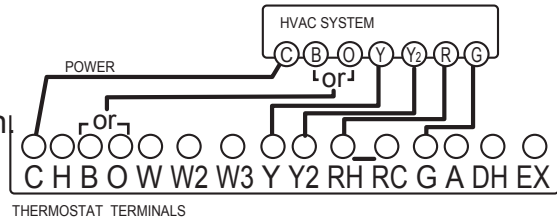

RC and RH connected



**WIRING** **C O or B AUX<sub>n</sub> Y<sub>n</sub> R G**

**Multi-stage Heat Pump with Multi-stage Aux Heat**

The CT80 can handle up to 2 stages of Pump compression and 3 stages of AUX heat.

STEP 1 - Connect O wire to the O terminal **or** B wire to the B terminal. This connects the change-over valve. If you have both O and B - connect only the O wire to the O terminal and DO NOT connect B to B terminal (see wire reference under Trane for B wire terminal).

STEP 2 - Connect the AUX 1, AUX 2, AUX 3 to the W, W2 and W3 respectively. This connects the auxiliary heat.

STEP 3 - Connect the Y and Y2 wires to the Y terminals. This connects the compressor.

STEP 4 - Connect the R (or RH) wire to RH terminal. This connects the power.

STEP 5 - Connect the G wire to G terminal. This connects the fan.

STEP 6 - Connect the C wire to the C terminal. Your HVAC system is now connected to the CT80.

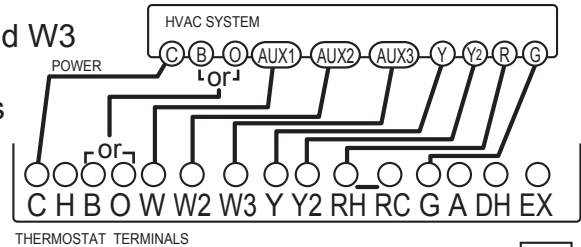

RC and RH connected

**← Please Go To Page 6**

**Accessory Wiring -**

**3 Wire Zoned Hot Water Heat -**

For 3 wire solenoid or motor valves connect the wires shown to the correct terminals on the CT80. If you have different letters than shown, go to page 20.

**FOR 3WIRE ZONED HOT WATER**

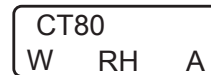

MOTOR VALVE

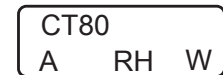

SOLENOID VALVE

## Humidifier -

To use the CT80 internal humidistat to control an external humidifier unit, connect it as shown. Connect the H terminal to the control leg of the humidifier relay. This allows H to turn the humidifier ON and Off.

## DeHumidifier -

To use the CT80 internal humidistat to control an external dehumidifier unit, connect it as shown. Connect the DH terminal to the control leg of the dehumidifier relay. This allows DH to turn the dehumidifier ON and OFF.

## Fresh Air -

The Fresh Air feature uses the EX relay to control a baffle on a fresh external air source. Connect the 24VAC baffle to C and EX terminals.

### FOR EXTERNAL HUMIDIFIER or DEHUMIDIFIER USING HVAC SYSTEM'S 24VAC

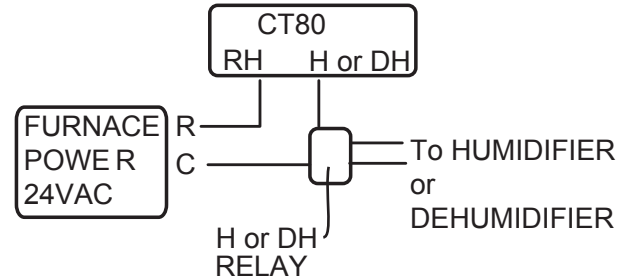

### FOR EXTERNAL HUMIDIFIER or DEHUMIDIFIER USING 24VAC ADAPTER

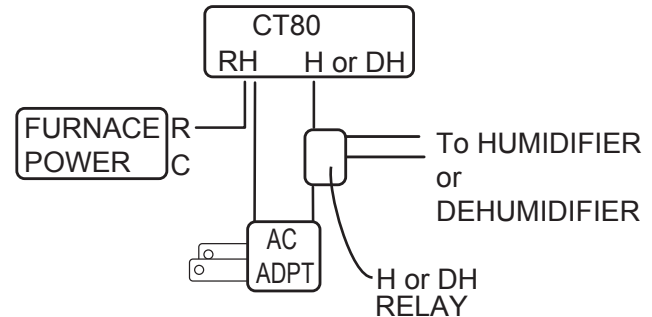

### FOR FRESH AIR BAFFLE

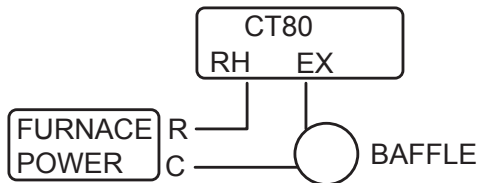

## Wire Reference Table

<i>Possible Wires</i>	<i>What They Control</i>
R or V or VR	<b>RH</b> and <b>RC</b> Single power for HEAT and COOL
RH or 4	<b>RH</b> Power for HEAT (RH not connected to RC with switch in UP position)
RC	<b>RC</b> Power for COOL (RH not connected to RC with switch in UP position)
W	<b>W</b> Heat control - Normal 1st stage heat or heat pump aux 1st stage
W2	<b>W2</b> Normal 2nd stage heat or heat pump aux 2nd stage
W3	<b>W3</b> Normal 3rd stage heat or heat pump aux 3rd stage
Y	<b>Y</b> COOL control or 1st stage compression for heat pump
Y2	<b>Y2</b> 2nd stage COOL control or 2nd stage compression for a heat pump
G or F	<b>G</b> FAN control
C or X	<b>C</b> 24VAC power (to power thermostat)
	NOTE: TRANE, AMERICAN STANDARD and YORK often use the letter B for C
H	<b>H</b> External Humidifier
DH	<b>DH</b> External De-Humidifier
EX	<b>EX</b> external fresh air baffle
B	<b>B</b> Heat pump changeover (cool to heat, powered in heat)
O	<b>O</b> Heat pump changeover (heat to cool, powered in cool)
B and O	<b>⚠ IMPORTANT: If you have a heat pump with both B and O wires (Trane pump products) DO NOT CONNECT B to B terminal, connect B to C terminal. Other Trane products use B letter for C wire.</b>
E	n/a Emergency heat (do not connect, tape off)
L	n/a System monitor (do not connect, tape off)
T	n/a Outdoor sensor (do not connect, tape off)

**Wire Ref Cont.****Lennox Heat Pump**

<b>V or VR or R</b>	<b>RH</b> Power for HEAT
<b>M or Y</b>	<b>Y</b> COOL control
<b>Y or W or W2</b>	<b>W2</b> 2nd stage HEAT
<b>F or G</b>	<b>G</b> Fan control
<b>R or O</b>	<b>O</b>
<b>X or X2 or C</b>	<b>C</b>

**Trane Products [American Standard]**

<b>B</b>	<b>C</b> 24VAC power (to power thermostat)
<b>X2</b>	Emergency heat (do not connect, tape off)

**Zoned Hot Water****2 wire****Your Wires**

<b>R</b>	<b>Thermostat Terminal</b>
<b>W</b>	<b>RH</b>
	<b>W</b>

**3 Wire****Solenoid Valves**

<b>R</b>	<b>RH</b> (power)
<b>W</b>	<b>A</b> (heat ON)
<b>Y or G</b> (the 3rd wire)	<b>W</b> (heat OFF)

**3 Wire****Motor Driven Valves**

<b>R or 5</b>	<b>RH</b> (power)
<b>W or 4</b>	<b>W</b> (heat ON)
<b>Y or G or 6</b> (the 3rd wire)	<b>A</b> (heat OFF)

## **APPENDIX 1 : Multi-staged HVAC theory of operation -**

### **Staging for 2 stage normal Cool and 2 stage heat pump Cool**

**Target Temperature Maintenance in COOL** - If the room temperature is within the target temperature plus the “2nd stg on at” setting, the 1st stage of cool will turn on. If the target temperature is not reached within 15 minutes, the 2nd stage of cool will turn on with the 1st stage to the target temperature.

**Target Temperature Recovery in COOL**- If the room temperature is beyond the new target temperature plus the “2nd stg on at” setting, the 1st stage will turn on. Ten seconds later, the 2nd stage will turn on with the 1st stage to the new target temperature.

There are two options for recovery: FAST and ECON. With FAST recovery, both stages stay on until the new target temperature is reached. With ECON recovery, both stages stay on until the “2nd stg on at” setting is reached. Then, the 2nd stage shuts off and the 1st stage stays on to the new target temperature.

### **Staging for 2 or 3 stages normal Heat**

**Target Temperature Maintenance in HEAT** - If the room temperature is within the target temperature minus the “2nd stg on at” setting, the 1st stage of heat will turn on. If the target temperature is not reached within 15 minutes, the 2nd stage of heat will turn on with the 1st stage to the target temperature. 3rd stage is not used for maintenance.

Example: Target 70F, “2nd stg on at” 2F, maintenance occurs at room temperatures of 69F and 68F.

**Target Temperature Recovery in HEAT**- If the room temperature is beyond the new target temperature minus the “2nd stg on at” setting, the 1st stage will turn on. Ten seconds later, the 2nd stage will turn on with the 1st stage. 10 seconds later the 3rd stage will come on with the 1st and 2nd stages.

There are two options for recovery: FAST and ECON. With FAST recovery, all stages stay on until the target temperature is reached. With ECON recovery, all stages stay on until the “2nd stg on at” setting is reached. Then, the 2nd and 3rd stages shut off and the 1st stage stays on to target.

### **Staging for Heat Pump with 2 stages of compression (no auxiliary)**

**Target Temperature Maintenance** - If the room temperature is within the target temperature minus the “2nd stg on at” setting, the 1st stage heat pump will turn on. If the target temperature is not reached within 15 minutes, the 2nd stage of heat pump will turn on with the 1st stage to target.

**Target Temperature Recovery** - If the room temperature is beyond the new target temperature minus the “2nd stg on at” setting, the 1st stage of heat pump will turn on. Ten seconds later, the 2nd stage of heat pump will turn on with the 1st stage.

There are two options for recovery: FAST and ECON. With FAST recovery, both heat pump stages stay on to the target. With ECON recovery, both heat pump stages stay on until the “2nd stg on at” setting is reached. Then, the 2nd stage heat pump shuts off and the 1st stage pump stays on to target.

### **Staging for 1 or 2 stages of Heat Pump, and up to 3 stages of aux heat**

**Target Temperature Maintenance** - If the room temperature is within the target temperature minus the “aux on at” setting, the auxiliary heat will not be used, just the heat pump (1 or 2 stages) as explained above in “target temperature maintenance”.

**Target Temperature Recovery** - If the room temperature is beyond the new target minus the “aux on at” setting, the 1st stage of heat pump will turn on, ten seconds later the 2nd stage of heat pump will turn on, ten seconds later the 1st stage of auxiliary heat will turn on. If the new target temperature is then not reached after 15 minutes, the 2nd stage of auxiliary heat will turn on. If the new target temperature is not reached 15 minutes after that, the 3rd stage of auxiliary heat will turn on.

There are two options for recovery: FAST and ECON. With FAST recovery all stages will stay on until the new target temperature is reached. With ECON recovery all stages will stay on until the “aux on at” setting is reached. Then all auxiliary heat goes off and only the heat pump is on to the target.

**ELECTRIC vs. GAS or OIL auxiliary heat** - With electric auxiliary heat, the heat pump stays on while the auxiliary heat is on. With gas or oil auxiliary heat, the heat pump will shut off while the auxiliary heat is on.

This is required by heat pump design.

## **APPENDIX 2 : FRESH AIR install and operation**

To use the FRESH AIR option; your system needs to have a fresh air baffle or an air to air exchanger. This unit needs to be in the closed/off position (outside air is blocked) when not energized (normally closed).

**Fresh Air baffle/ air to air exchanger installation** - Connect one end of the wire to the HVAC's C terminal and connect the other end to EX terminal on the thermostat. When Fresh Air is requested, the thermostat energizes EX (connects EX to RH).

The CT80 has two methods of providing Fresh Air - FAN FRESH AIR and MANUAL FRESH AIR. FAN FRESH AIR can be accessed from the HOME screen. Touch the FAN icon and choose FRESH. The fresh air baffle or air to air exchanger will activate every time the heat or cool comes on to add fresh air to your home. To use MANUAL FRESH AIR from the HOME screen, touch the FAN icon. Choose FRESH and touch ON. The fan will run continuously with fresh air until FAN control is returned to AUTO.

**Energy saving with Fresh Air.** You can use your FRESH AIR baffle as a source of HEAT or COOL - Your fresh air baffle can help you save money by allowing you to use it as your first stage of Heat or Cool depending on the outside air temperature. For example, you can use it to cool off the house after a hot day when the outdoor night time temperature cools down lower than the indoor temperature.

To do this in the Heat or Cool mode from the HOME screen, touch the main temperature display to go to the temporary screen. At the temporary screen touch FRESH AIR. The fresh air baffle will open and the fan will turn on when the system calls for HVAC. The outside air will now be used to heat or cool the house. The thermostat will use Fresh Air until the next program time slot is reached. At the next time slot, the thermostat will revert to regular non-fresh operation.

The thermostat will revert to normal HVAC control if the room temperature does go the wrong way ( ie. increases in COOL mode) by 3°F or if the target temperature is not reached within 30 minutes while using FRESH AIR.