

Model XPH07M/XPH07Z Parts List

A = Standard Equipment

O = Circuit Diagram

Item#	MJ Part#	Description	Q'ty	Unit
001	187921-4	HOUSING SET	1	
	C10 263005-3	RUBBER PIN 6	2	PC.
	D10	INC. 21		
002	815S70-8	XPH07 NAME PLATE	1	
003	266130-9	TAPPING SCREW BIND PT 3X16	7	PC.
004	232220-0	LEAF SPRING	2	PC.
005	126411-2	SPEED CHANGE LEVER ASSEMBL	1	
	C10 233438-6	COMPRESSION SPRING 4	2	PC.
006	419250-0	F/R CHANGE LEVER	1	PC.
007	650710-5	SWITCH C3JW-4B	1	
008	251468-5	- FLAT HEAD SCREW M6X22	1	PC.
009	766015-4	KEYLESS DRILL CHUCK 13	1	PC.
010	265995-6	TAPPING SCREW 4X18	4	PC.
011	126410-4	GEAR ASSEMBLY	1	
012	142263-3	INDICATOR PANEL COMPLETE	1	
013	424517-3	CUSHION	1	PC.
014	629116-8	STATOR COMPLETE	1	PC.
015	619336-2	ROTOR	1	
016	266130-9	TAPPING SCREW BIND PT 3X16	2	PC.
017	455011-4	REAR COVER	1	
018	620283-2	LED CIRCUIT	1	
019	643899-6	TERMINAL	1	PC.
020	803N96-2	CAUTION LABEL	1	
021	187921-4	HOUSING SET	1	
	C10 263005-3	RUBBER PIN 6	2	PC.
	D10	INC. 1		
A01	122576-8	STOPPER POLE ASS'Y	1	PC.
A02	126413-8	GRIP ASSEMBLY	1	
	C10 142652-2	POLE COMPLETE	1	
	C20 142653-0	ARM R COMPLETE	1	
	C30 265785-7	THUMB SCREW M5X10	1	PC.
	C40 266886-4	HEX. BOLT M8X65	1	
	C50 319129-4	ARM L	1	
	C60 931202-6	HEX. NUT M5	1	PC.
	C70 962055-2	RETAINING RING (INT) R-15	1	PC.
A03	251314-2	+ SCREW M4X12	2	PC.
A04	346449-3	HOOK	1	PC.
A05	452947-8	BIT HOLDER	1	PC.
A06	784637-8	+ BIT 2-45	2	PC.
A07	821524-1	PLASTIC CARRYING CASE	1	PC. (XPH07M)
	C10 162302-3	LATCH	2	PC.
	C20 325809-2	SHAFT	1	PC.
	C30 451749-9	HANDLE	1	PC.
	C40 453473-0	PLASTIC CASE LID	1	PC.
A08	***DC18RC	DC18RC FAST CHARGER	1	PC. (XPH07M)
A09	BL1840	BATTERY BL1840 SET (196402-7)	2	(XPH07M)
A10	450128-8	BATTERY COVER	1	PC. (XPH07M)

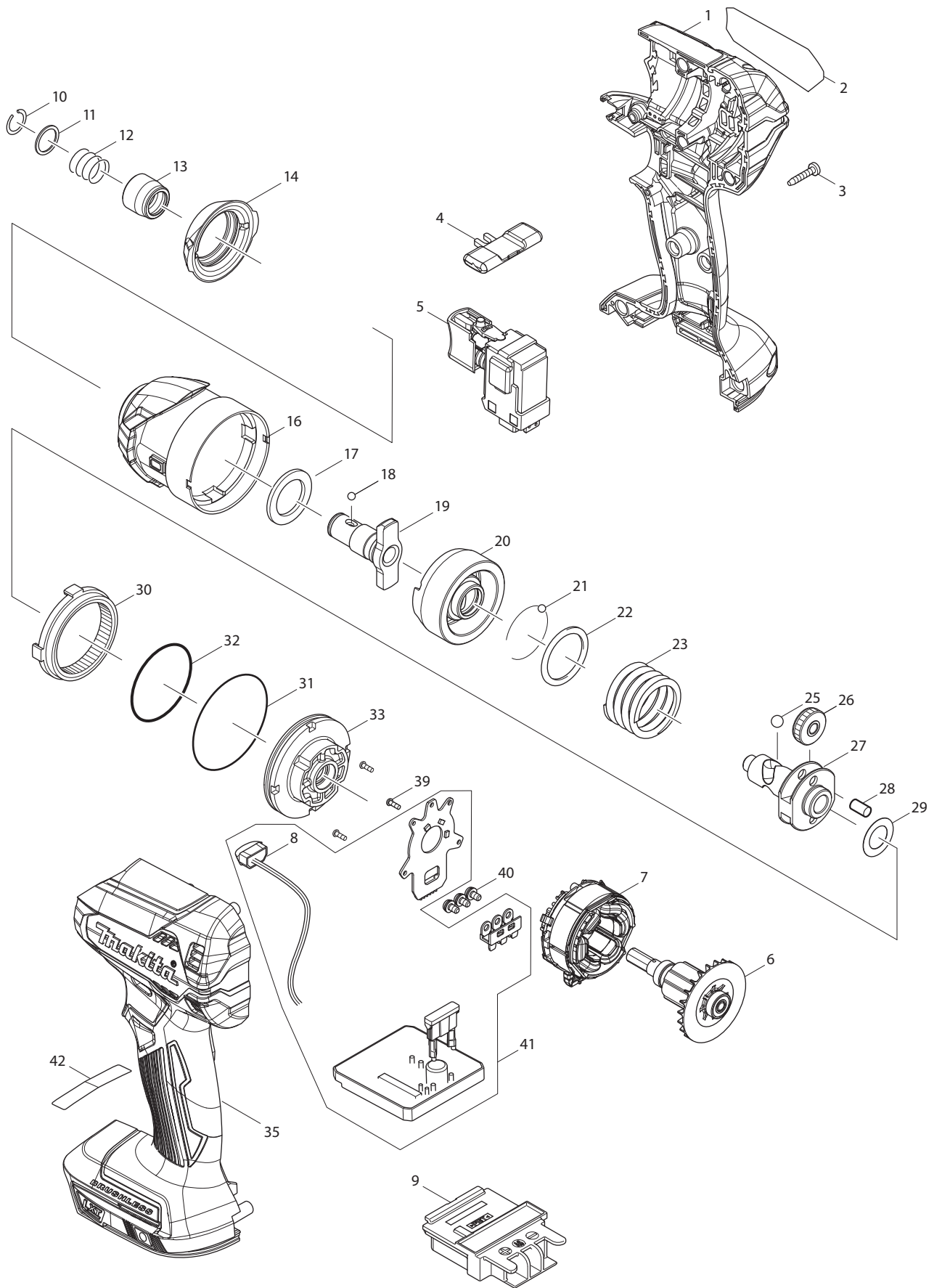

Model XDT13M/R/Z Parts List

A = Standard Equipment

O = Circuit Diagram

Item#	Part#	Description	Q'ty	Unit
001	183E34-9	HOUSING SET	1	
	C10 263005-3	RUBBER PIN 6	2	PC.
	C20 252126-6	HEX. LOCKING NUT M4-7	2	PC.
	D10	INC. 35		
002	852K78-3	XDT13 NAME PLATE	1	
003	266429-2	TAPPING SCREW 3X16	9	PC.
004	455053-8	F/R CHANGE LEVER	1	PC.
005	143975-1	SWITCH COMPLETE	1	
006	619404-1	ROTOR	1	
007	629224-5	STATOR	1	
008	620557-1	LED CIRCUIT	1	
009	643860-3	TERMINAL	1	PC.
010	231951-8	RING SPRING 11	1	PC.
011	267085-1	FLAT WASHER 12	1	PC.
012	233005-7	COMPRESSION SPRING 13	1	PC.
013	326068-1	BIT SLEEVE	1	PC.
014	424888-8	BUMPER	1	
016	143957-3	HAMMER CASE COMPLETE	1	
017	261151-6	NYLON WASHER 19	1	PC.
018	216040-0	STEEL BALL 3.5	2	PC.
019	326563-1	ANVIL M	1	
020	326564-9	HAMMER	1	
021	216040-0	STEEL BALL 3.5	24	PC.
022	267175-0	FLAT WASHER 24	1	PC.
023	234251-5	COMPRESSION SPRING 25	1	PC.
025	216041-8	STEEL BALL 5.6	2	
026	227362-3	SPUR GEAR 22	2	PC.
027	326562-3	SPINDLE	1	
028	256253-1	PIN 5	2	PC.
029	253314-8	THIN WASHER 15	1	PC.
030	227378-8	INTERNAL GEAR 51	1	
031	213606-7	O RING 48	1	PC.
032	213507-9	O RING 40	1	PC.
033	143958-1	BEARING BOX COMPLETE	1	
035	183E34-9	HOUSING SET	1	
	C10 263005-3	RUBBER PIN 6	2	PC.
	C20 252126-6	HEX. LOCKING NUT M4-7	2	PC.
	D10	INC. 1		
039	266490-9	TAPPING SCREW PT 2X6	3	PC.
040	652069-6	FLAT HEAD SCREW M3X6	3	PC.
041	620556-3	CONTROLLER	1	
	D10	INC. 8		
042	809R90-6	CAUTION LABEL	1	
A01	266622-8	+ TRUSS HEAD SCREW M4X12	1	PC.
A02	346449-3	HOOK	1	PC.
A03	450128-8	BATTERY COVER	1	PC. (XDT13M/R)
A04	***DC18RC	DC18RC FAST CHARGER	1	PC. (XDT13M/R)
	D10	COMPO-PARTS		
A05	BL1840B	BATTERY BL1840B SET	2	(XDT13M)

	BL1820B	BATTERY BL1820B SET	2	(XDT13R)
A06	141856-3	PLASTIC CARRYING CASE COMPLETE	1	PC. (XDT13M/R)
C10	162302-3	LATCH	2	PC. (XDT13M/R)