

1 YEAR LIMITED WARRANTY

For one year from date of purchase, Malibu Lighting Corporation warrants the Malibu Low Voltage Lights against defects due to workmanship or materials to the original purchaser. The Malibu Lighting Corporation's obligations under this warranty are limited to the following guidelines:

- This warranty does not cover units that have been altered/modified or damaged due to: normal wear, rust, abuse, improper maintenance and/or improper use.
- This warranty does not cover surface scratches to fixtures or transformer, which is considered normal wear.
- Malibu Lighting Corporation may elect to repair or replace damaged units covered by the terms of this warranty.
- This warranty extends to the original purchaser only and is not transferable or assignable to subsequent purchasers.

Malibu Lighting Corporation requires reasonable proof of purchase. Therefore, we strongly recommend that you retain your sales receipt or invoice. To obtain repair or replacement of your Malibu Low Voltage Lights under the terms of this warranty, please call Customer Service Department at 888-295-7348 for a Return Authorization Number and further instructions. A receipt or proof of purchase will be required. Malibu Lighting Corporation will not be responsible for any units forwarded to us without a Return Authorization Number.

EXCEPT AS ABOVE STATED, THE MALIBU LIGHTING CORPORATION MAKES NO OTHER EXPRESS WARRANTY.

THE IMPLIED WARRANTIES OF MERCHANTABILITY AND FITNESS FOR A PARTICULAR PURPOSE ARE LIMITED IN DURATION TO ONE YEAR FROM THE DATE OF PURCHASE. SOME STATES DO NOT ALLOW LIMITATIONS ON HOW LONG AN IMPLIED WARRANTY LASTS, SO THE ABOVE LIMITATION MAY NOT APPLY TO YOU.

ANY LIABILITY FOR INDIRECT, INCIDENTAL OR CONSEQUENTIAL DAMAGES ARISING FROM THE FAILURE OF THE MALIBU LOW VOLTAGE LIGHTS TO COMPLY WITH THIS WARRANTY OR ANY IMPLIED WARRANTY IS EXCLUDED. CUSTOMER ACKNOWLEDGES THAT THE PURCHASE PRICE CHARGED IS BASED UPON THE LIMITATIONS CONTAINED IN THE WARRANTY SET OUT ABOVE. SOME STATES DO NOT ALLOW THE EXCLUSION OR LIMITATION OF INCIDENTAL OR CONSEQUENTIAL DAMAGES, SO THE ABOVE LIMITATION OR EXCLUSION MAY NOT APPLY TO YOU. THIS WARRANTY GIVES YOU SPECIFIC LEGAL RIGHTS, AND YOU MAY ALSO HAVE OTHER RIGHTS WHICH VARY FROM STATE TO STATE.

1 AÑO DE GARANTÍA LIMITADA

Durante un año a partir de la fecha de compra, Malibu Lighting Corporation garantiza al comprador original que las luces Malibu de Baja Tensión está libre de defectos de materiales o mano de obra. Las obligaciones de Malibu Lighting Corporation con respecto a esta garantía se limitan a lo siguiente:

- Esta garantía no cubre unidades que hayan sido alteradas/modificado o dañadas debido a: uso normal, herrumbre, maltrato, mantenimiento inadecuado y/o uso inapropiado.
- Esta garantía no cubre rayones superficiales a los accesorios o caja de energía, daño por herrumbre o por calor al acabado, lo cual se considera como uso normal.
- Malibu Lighting Corporation puede decidir reparar o reemplazar las unidades dañadas cubiertas bajo los términos de esta garantía.
- Esta garantía se otorga al comprador original únicamente y no es transferible o asignable a los compradores posteriores.

Malibu Lighting Corporation exige un comprobante de compra razonable. Por lo tanto, le recomendamos enfáticamente que retenga su recibo o factura de venta. Para solicitar reparación o reemplazo de la Luces Malibu de Baja Tensión de conformidad con los términos de esta garantía, sírvase llamar al Departamento de Atención al Cliente al 888-295-7348 para recibir un Número de autorización de devolución y otras instrucciones. Se requerirá el recibo o comprobante de compra. Malibu Lighting Corporation no puede asumir responsabilidad por unidades que sean enviadas a nosotros sin un Número de autorización de devolución.

EXCEPTO POR LO INDICADO ARRIBA, MALIBU LIGHTING CORPORATION NO OTORGA NINGUNA OTRA GARANTÍA EXPRESA.

LAS GARANTÍAS IMPLÍCITAS DE COMERCIABILIDAD Y ADECUACIÓN CON UN FIN EN PARTICULAR SON DE DURACIÓN LIMITADA DE ACUERDO A LO INDICADO ARRIBA A PARTIR DE LA FECHA DE COMPRA. ALGUNOS ESTADOS NO PERMITEN LIMITACIONES DE DURACIÓN DE UNA GARANTÍA IMPLÍCITA; POR LO TANTO, LA LIMITACIÓN ANTERIOR PODRÍA NO SER APLICABLE EN SU CASO.

SE EXCLUYE CUALQUIER RESPONSABILIDAD POR DAÑOS INDIRECTOS, INCIDENTALES O CONSIGUIENTES DERIVADOS DE LA FALTA DE CUMPLIMIENTO DE ESTA GARANTÍA O DE CUALQUIER GARANTÍA IMPLÍCITA DE LUCES MALIBU DE BAJA TENSIÓN. EL CLIENTE RECONOCE QUE EL PRECIO DE COMPRA COBRADO SE BASA EN LAS LIMITACIONES CONTENIDAS EN LA GARANTÍA ANTERIOR. ALGUNOS ESTADOS NO PERMITEN LA EXCLUSIÓN O LIMITACIÓN DE LOS DAÑOS INCIDENTALES O CONSIGUIENTES; POR LO TANTO, LA LIMITACIÓN O EXCLUSIÓN ANTERIOR PODRÍA NO SER APLICABLE EN SU CASO. ESTA GARANTÍA LE OTORGA DERECHOS LEGALES ESPECÍFICOS Y USTED PUEDE TENER ADEMÁS OTROS DERECHOS QUE VARÍAN DE UN ESTADO A OTRO.

GARANTIE LIMITÉE DE 1 AN

Malibu Lighting Corporation garantit Malibu Éclairage de Basse Tension pendant 1 an à compter de la date d'achat contre les défauts de fabrication ou de matières à l'acheteur initial. Aux termes de la présente garantie, les obligations de Malibu Lighting Corporation se limitent à ce qui suit:

- La présente garantie ne couvre pas les fumoirs altérés, modifiés ou endommagés par suite : de l'usure normale, la corrosion, d'un usage abusif, d'un entretien inadéquat ou d'une utilisation incorrecte.
- La présente garantie ne couvre pas les rayures superficielles ou les dégâts/décoloration au fini occasionnés par la chaleur, car ils sont considérés comme faisant partie de l'usure normale.
- Malibu Lighting Corporation peut choisir de réparer ou remplacer les appareils endommagés couverts par les termes de la présente garantie.
- La présente garantie ne s'adresse qu'à l'acheteur initial et ne peut être transférée ou cédée aux acheteurs ultérieurs.

Malibu Lighting Corporation exige une preuve d'achat raisonnable. Nous vous recommandons donc vivement de conserver votre preuve d'achat ou facture. Pour obtenir une réparation ou le remplacement de votre Malibu Éclairage de Basse Tension au titre de cette garantie, veuillez appeler le Service à la clientèle au 888-295-7348 pour obtenir un numéro d'autorisation de retour et de plus amples instructions. Une réception ou une preuve d'achat est exigée. Le numéro d'autorisation de retour doit être clairement indiqué sur la paroi extérieure de la boîte. Malibu Lighting Corporation n'est pas responsable de toutes unités retournés sans numéro d'autorisation de retour.

LA GARANTIE OFFERTE PAR MALIBU LIGHTING CORPORATION NE COUVRE EXPRESSÉMENT QUE CE QUI PRÉCÈDE.

LES GARANTIES TACITES DE VALEUR COMMERCIALE ET D'ADAPTATION À UN USAGE PARTICULIER SONT LIMITÉES À UN AN À COMPTER DE LA DATE DE L'ACHAT. CERTAINES PROVINCES INTERDISSENT DE LIMITER LA DURÉE D'UNE GARANTIE TACITE. LA LIMITE QUI PRÉCÈDE PEUT PAR CONSÉQUENT NE PAS S'APPLIQUER À L'ACHETEUR.

TOUTE RESPONSABILITÉ POUR DES DOMMAGES INDIRECTS, FORTUITS OU CONSÉQUENTS DUS À L'INOBSERVATION PAR L'ACHETEUR MALIBU ÉCLAIRAGE DE BASSE TENSION DES TERMES DE LA PRÉSENTE GARANTIE OU DE TOUTE GARANTIE TACITE EST EXCLUE. LE CONSOMMATEUR RECONNAÎT QUE LE PRIX D'ACHAT FACTURÉ EST BASÉ SUR LES DÉLAIS DE PRESCRIPTION POUR LA GARANTIE DE L'ENSEMBLE CI-DESSUS. CERTAINS ÉTATS, PROVINCES OU PAYS NE PERMETTENT PAS L'EXCLUSION OU LA RESTRICTION DES DOMMAGES INDIRECTS OU MATÉRIELS. PAR CONSÉQUENT, LES RESTRICTIONS OU LES EXCLUSIONS MENTIONNÉES CI-DESSUS POURRAIENT NE PAS S'APPLIQUER À VOTRE CAS. CETTE GARANTIE VOUS DONNE DES DROITS SPÉCIFIQUES, ET VOUS POUVEZ ÉGALEMENT AVOIR D'AUTRES DROITS QUI VARIENT D'UNE PROVINCE À L'AUTRE.

Malibu Lighting Corporation
All intellectual property rights are used under license from
J. Baxter Brinkmann International Corporation
Todos los derechos de propiedad intelectual se utilizan bajo licencia de
J. Baxter Brinkmann International Corporation
Tous les droits de propriété intellectuelle sont utilisées sous licence de
J. Baxter Brinkmann International Corporation

1401-5530-40
0714

© 2014
Dallas, Texas 75244
www.MalibuLights.com



FOR MODEL 8401-5530-01

LED Low Voltage Light Fixture

SAVE THESE INSTRUCTIONS

READ BEFORE
USING THIS PRODUCT.

Instructions for Assembling and Installing Malibu® Light Fixture

⚠ WARNING: Risk of Fire or Electrical Shock

- For use with OUTDOOR low voltage landscape lighting systems ONLY.
- NOT FOR USE with submersible or pool/spa equipment.
- Do not install within 10 feet (3 m) of pools, spas, or fountains.
- Do not connect with wet hands.
- Do not submerge in water, the product can be damaged.
- Do not repair or modify this product.
- This product is not a toy and must not be operated by children.
- Low voltage cable can be buried to a maximum of 6 inches.
- Keep away from materials that may burn. Do not operate the luminaire fitting with a missing or damaged lens.
- If necessary to splice cable, carefully follow instructions that came with the connector you have purchased.
- The included cable connectors are to be used only on low voltage power cable with SPT-3W or equivalent 18, 16, 14, or 12AWG cable.
- The fixture's cable and connector shall:
 - Be protected by routing in close proximity to the light fixture, or next to a building structure such as a house or deck.
 - Not be buried except for a maximum 6 inches (15.2 cm) to connect to the main low voltage cable.
 - Have a length such that the connector is within six inches (15.2 cm) from the light fixture or a building structure.
- Do not use cable smaller than listed in chart below.

SELECT CABLE. Use the chart below to determine the MINIMUM gauge cable to be used, depending on the wattage of the power pack. Using larger cable will ensure maximum light output. For Malibu cable, contact your supplier.

Power Pack Wattage	Minimum Gauge Cable
217-300	12
157-216	14-12
121-156	16-14-12
0-120	18-16-14-12

BEFORE FIRST USE –

1. Turn fixture head on its side. Remove battery compartment cover and gasket with a phillips head screwdriver. Remove battery from packaging.
2. Install rechargeable 900mAh LiFePO4 battery. Make sure the battery is installed with the correct polarity. Light will automatically turn on when battery is installed.
3. Replace battery compartment lid and gasket.
4. Select either HIGH (H) or LOW (L) for your preferred level of illumination.
5. When replacing battery, recycle or dispose of used battery properly. Do not puncture, short circuit, or dispose of in fire.
6. For low voltage landscape lighting operation, place the light fixture on the ground stake assembly. The orientation of the fixture head on the ground stake does not matter. Light will automatically switch from battery mode to low voltage lighting mode and light up if the power pack is ON. Battery will recharge during normal nighttime landscape lighting operation. Battery will only discharge when the fixture is removed from the ground stake and the light comes ON.

⚠ WARNING: Risk of Fire or Electrical Shock

- Read power pack instruction sheet before attempting to install or hook up the power pack. Failure to follow directions may result in **Risk of Fire or Electric Shock**.
- Use only CSA or UL approved low-voltage cable. Failure to the correct gauge cable or install it as directed in these instructions may result in **Risk of Fire or Electric Shock**.

⚠ CAUTION:

- To avoid risk of eye injury, do not stare at bright light.

Assemble the fixture

- 1) Assemble fixture as shown in illustration. Be sure to run wire leads through slot in stake.

- 2) Lay the fixtures out where you want to locate them. The first fixture should be at least 10 wire feet from the power pack. **WARNING-RISK OF ELECTRICAL SHOCK: Do not place a fixture within 10 feet of a pool or spa.**
- 3) With cable connected to power pack (SEE POWER PACK INSTRUCTION SHEET) and power pack switched on, attach each fixture to power cable using cable connectors as shown. Separate the connector parts. Push cable all the way into the U-shaped slot. Thread the cap onto the U-shaped piece, turning clockwise to secure tightly. Prongs will pierce cable to make contact and illuminate fixture. **The fixtures will illuminate when the connection is complete.**
- 4) To install, loosen ground with a shovel or soften soil with water, then press stake into ground. **NOTE: Make certain that the ground stake is firmly planted deep into the soil to keep the light from falling over. Do not use hammer. Do not push head of fixture to install stake into ground as it may break fixture.**

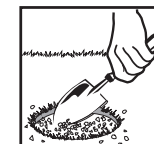

For dependable performance, use genuine Malibu replacement parts.

For customer service or to purchase replacement parts please visit our web site:

www.malibulights.com

or call Monday - Friday,
8:30am - 5:00pm (CST)
888-295-7348

IMPORTANT: Please have product model number available when ordering.

YOU MUST KEEP YOUR RECEIPT FOR PROOF OF PURCHASE.

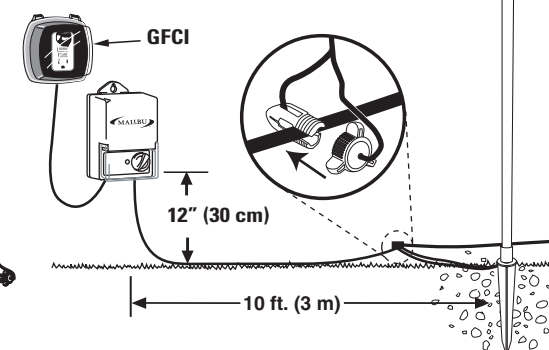

Note: This equipment has been tested and found to comply with the limits for a Class B digital device, pursuant to part 15 of the FCC Rules. These limits are designed to provide reasonable protection against harmful interference in a residential installation. This equipment generates, uses and can radiate radio frequency energy and, if not installed and used in accordance with the instructions, may cause harmful interference to radio communications. However, there is no guarantee that interference will not occur in a particular installation. If this equipment does cause harmful interference to radio or television reception, which can be determined by turning the equipment off and on, the user is encouraged to try to correct the interference by one or more of the following measures:

- Reorient or relocate the receiving antenna.
- Increase the separation between the equipment and receiver.
- Connect the equipment into an outlet on a circuit different from that to which the receiver is connected.
- Consult the dealer or an experienced radio/TV technician for help.