

## Assembly Instructions Model: TXB48

### Parts

- (1) Seat
- (1) Back
- (2) Sideframes
- (1) Hardware pack

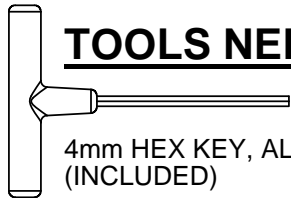

### TOOLS NEEDED

4mm HEX KEY, ALLEN, T-HANDLE  
(INCLUDED)

### Step 1

Attach sideframes to seat using (4) 1¾" chair bolts (A).  
DO NOT TIGHTEN!!

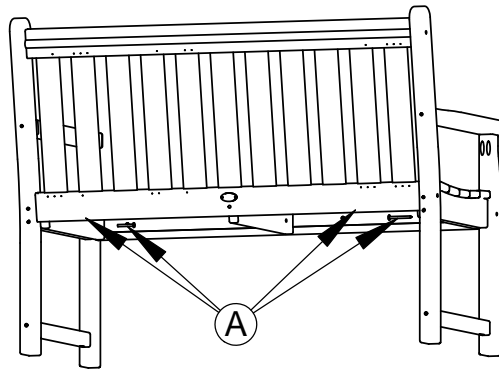

### Step 2

- Attach back to sideframes using (2) 1¾" chair bolts (A) into the tube on top and (4) 2½" screws (B) on bottom

- Attach center of the back to the seat using (1) 2½" screw (B)

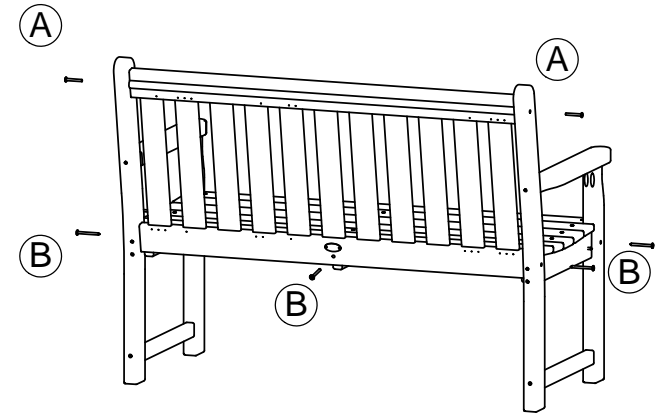

### Step 3

Tighten the 1¾" chair bolts from Step 1

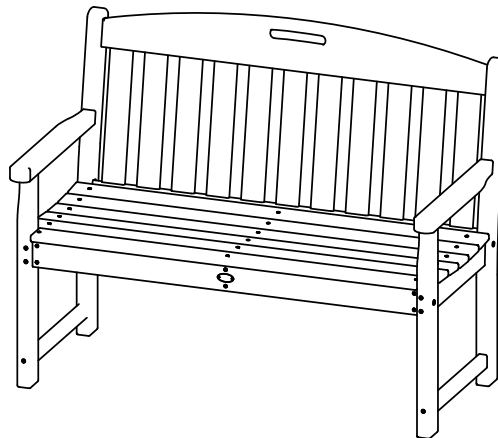

Qty.	Description
6	A - 1/4-20 X 1-3/4 WAFER SHCS
5	B - .27 X 2-1/2 SOCKET WAFER A

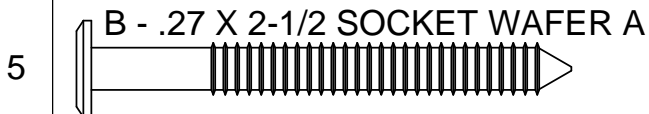
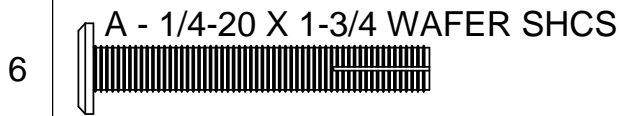

ALL HARDWARE IS COATED STAINLESS STEEL