



**STRONGER
THAN STEEL.™**

ProSTUD® DRYWALL
FRAMING SYSTEM

ClarkDietrich.

WHERE INNOVATION
TAKES FORM.

The ProSTUD® Drywall Framing System can be called many things. Strong. Versatile. Fast. And without a doubt—revolutionary. But one of the biggest benefits to keep in mind is this: ProSTUD was developed, tested and approved by pros in the field who demanded nothing less than achieving absolute ease of use. Its performance has also been proven by the most extensive laboratory evaluations available. All of which means ProSTUD comes with complete confidence and no questions about code compliance. With the backing of online, mobile and data-rich BIM resources, there’s no better example of a broader vision at work.

ProSTUD, in fact, is just one example of how ClarkDietrich can reinforce your efforts to design and build more intelligently. Yes, we’re known as a manufacturer of extensively tested, code-compliant steel framing products, but we offer so much more. Our products perform as a system. We support a range of efforts for smarter installation and design. We

provide the expertise of a versatile engineering services team. And we do it all on a nationwide scale.

We’ve put together an incredible array of resources to help you be successful on any project, regardless of size or complexity. Within this catalog you’ll discover the multiple advantages ProSTUD has to offer, as well as detailed information on the product lineup, limiting heights, sound and fire assemblies, and more.

Ultimately, your choice of ProSTUD doesn’t come down to the integrity of the product alone, or even its ease of use. You’re also looking to the strength of the company that stands behind it. Count on the expertise, services and full support of ClarkDietrich today—and far into the future.

Need Product Submittals?

Use **SubmittalPro®** at clarkdietrich.com.

TABLE OF CONTENTS

ProSTUD Drywall Framing System		Non-Composite Limiting Heights Tables	
Overview	2	Fully Braced	12
Profile Information	3	Braced at 48" o.c.	13
Physical & Structural Properties		Sound Testing	
ProSTUD 25	4	Sound Assemblies	14–15
ProSTUD 20	5	Fire Testing	
ProSTUD 30MIL	6	UL® Listed Wall Assemblies	16
ProSTUD 33MIL	7	Connections	
Connections		Deflection Track Systems	17
Allowable Screw Design Values	8	Ceiling Span Tables	18
High-Impact Gypsum Board	8	General	
Limiting Heights Overview	9	LEED® Information	19
Composite Limiting Heights Tables	10–11	Support Tools	20
		Code Compliance and Certification	21

WHAT IS AN EQUIVALENT (EQ) DRYWALL STUD?

Gauge equivalent drywall framing must meet the minimum performance requirements of conventional drywall framing as defined by the Steel Framing Industry Association (SFIA) and the Steel Stud Manufacturers Association (SSMA). The industry’s “EQ” product of choice, ProSTUD[®], employs roll-forming and steel-making technology, exceeding the performance of conventional drywall framing for allowable moment and screw connection strength. When comparing drywall framing systems, it is important to keep in mind Life Safety, System Performance and Connections. The ProSTUD Drywall Framing System provides peace of mind for all three important functions by providing the right selection of products and product data for every application.

ProSTUD Drywall Framing		Conventional Drywall Framing	
ProSTUD 25	15mil	25 Gauge	18mil
ProSTUD 20	19mil	20 Gauge	30mil

Life Safety

Life Safety is the primary concern and duty of all construction and design professionals. For interior drywall framing members, bending strength is the criteria most important to the strength of a wall or ceiling. AISI defines bending or flexural strength by Allowable Moment. The corresponding chart compares the bending strength of ProSTUD and conventional drywall studs.

Allowable Bending Capacity, 3-5/8" Stud

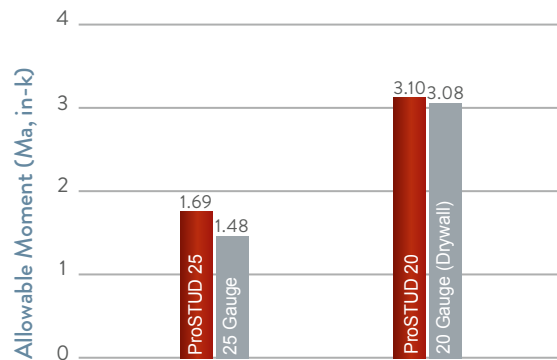

System Performance

Given ProSTUD’s strength and versatility, it’s important to know the performance of the ProSTUD member under your project’s specific criteria. This catalog will provide guidance in a variety of assemblies and loading criteria, based on current building codes. Additional data is available at clarkdietrich.com.

Connections

In addition to sufficient member strength, it’s important to know how connections will perform. Connections can be critical to the capacity and safety of an assembly, but they are also important for the attachment of cabinets, shelving, handrails, and other accessories to steel framing. The tables below compare the screw performance of ProSTUD to conventional drywall framing. This performance relationship to conventional studs can be applied to a variety of fasteners and connections.

#6 Screw Pullout Values

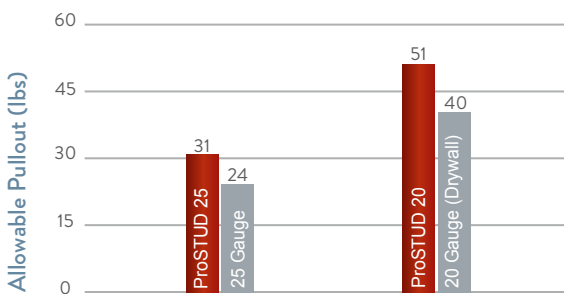

#6 Screw Shear (Bearing) Values

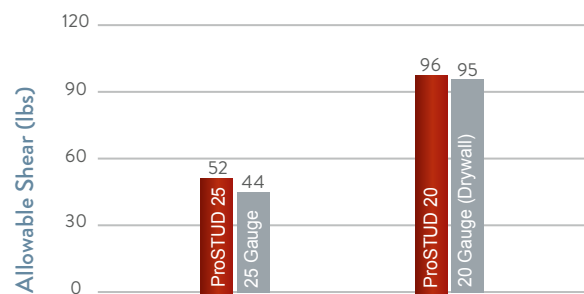

Along with connection capacity, conventional framing members are required to meet performance criteria for screw spinout. ProSTUD was developed with screw performance in mind. High-strength steel, flange stiffening grooves, web embossments, and knurling features combine to provide the best performance per thickness, exceeding the requirements of ASTM C645.

CONSTRUCTION ADVANTAGES

- High-strength steel combined with low-profile flange stiffening grooves and double offset web planking increases strength and provides greater limiting heights
- Diamond-embossed web creates stiffness, reducing flange fade and screw spinout during drywall installation
- Strong, lightweight stud and track cuts and handles easier than conventional flat steel studs
- Flange grooves provide sight line for drywall alignment and aid in positioning screws at drywall joints to maintain the 3/8" edge requirement
- Web and leg enhancements in ProTRAK® provide straight and rigid legs, making it the best choice for framing walls, headers, soffits, and bulkheads

DESIGN ADVANTAGES

- Designed to meet the additional strength requirements of today's building codes: IBC 2003, 2006, 2009 & 2012, AISI NASPEC (S100), ICC-ES AC86 (2010)
- UL Classified and listed in over 50 designs, including U419, V438, and chase wall assemblies
- Exceptional sound performance in over 50 tested sound assemblies
- Can contribute up to 7 LEED® Credits under LEED for New Construction and Major Renovations (LEED-NC Ver. 2.2 and 3.0)
- National availability

ProSTUD®

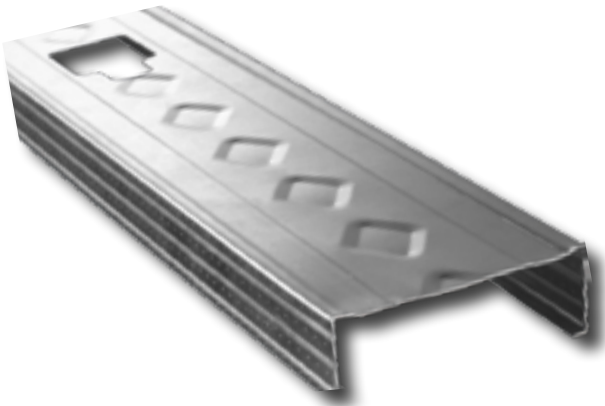

- Web Widths: 1-5/8," 2-1/2," 3-1/2," 3-5/8," 4," 5-1/2," and 6"
- Flange: 1-1/4"
- Return Lip: varies by stud size
- **Material Thicknesses:**
 ProSTUD 25 / 15mil (25ga EQ) 50ksi
 ProSTUD 20 / 19mil (20ga EQ) 65ksi
 ProSTUD 30MIL 33ksi
 ProSTUD 33MIL 33ksi
- Available G40EQ, G40, or G40EQ DiamondPlus (CP60 available as special order)

ProSTUD Profile

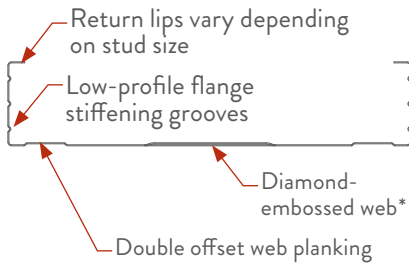

Shipping / Stacking

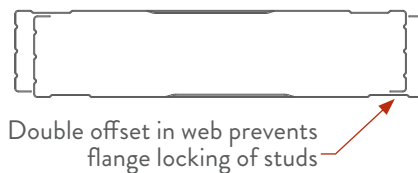

Drywall Joint

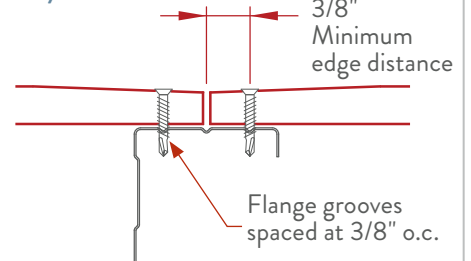

*Except in 1-5/8"

ProTRAK

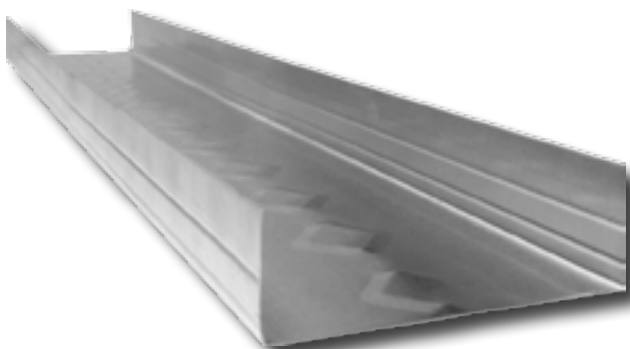

- Web Widths: 1-5/8," 2-1/2," 3-1/2," 3-5/8," 4," 5-1/2," and 6"
- Legs: 1," 1-1/4," 1-1/2," 2," 2-1/2," and 3"
- **Material Thicknesses:**
 ProTRAK 25 / 15mil (25ga EQ) 50ksi
 ProTRAK 20 / 19mil (20ga EQ) 50ksi
 ProTRAK 30MIL 33ksi
 ProTRAK 33MIL 33ksi
- Available G40EQ, G40, or G40EQ DiamondPlus (CP60 available as special order)

ProSTUD® 25 DRYWALL STUD

ClarkDietrich ProSTUD 25 (15mil) physical and structural properties

Member	Design thickness (in)	Fy (ksi)	Gross Section Properties						Effective Section Properties at Fy						Torsional Properties					Lu (in)
			Area (in ²)	Weight (lb/ft)	Ix (in ⁴)	Rx (in)	Iy (in ⁴)	Ry (in)	Ae (in ²)	Ix (in ⁴)	Sx (in ³)	Ma (in-lbs)	Vag (lb)	Vanet (lb)	Jx1000 (in ⁴)	Cw (in ⁶)	Xo (in)	Ro (in)	β Beta	
162PDS125-15	0.0158	50	0.071	0.24	0.033	0.688	0.015	0.466	0.033	0.030	0.024	719	232	104	0.00589	0.009	-1.088	1.369	0.368	24.8
250PDS125-15	0.0158	50	0.085	0.29	0.088	1.020	0.018	0.459	0.033	0.080	0.044	1198	147	141	0.00704	0.023	-0.959	1.473	0.576	24.5
362PDS125-15 ¹	0.0158	50	0.102	0.35	0.206	1.420	0.020	0.442	0.034	0.190	0.056	1689	100	100	0.00852	0.051	-0.837	1.706	0.760	24.3
400PDS125-15 ¹	0.0158	50	0.108	0.37	0.260	1.549	0.021	0.436	0.034	0.233	0.062	1870	90	90	0.00901	0.064	-0.803	1.798	0.800	24.2
600PDS125-15 ²	0.0158	50	0.140	0.48	0.683	2.209	0.023	0.404	0.034	0.537	0.105	2781	60	60	0.01164	0.161	-0.666	2.343	0.919	23.6

ProTRAK® 25 DRYWALL TRACK

ClarkDietrich ProTRAK 25 (15mil) physical and structural properties

Member	Design thickness (in)	Fy (ksi)	Gross Section Properties						Effective Section Properties at Fy						Torsional Properties				
			Area (in ²)	Weight (lb/ft)	Ix (in ⁴)	Rx (in)	Iy (in ⁴)	Ry (in)	Ae (in ²)	Ix (in ⁴)	Sx (in ³)	Ma (in-lbs)	Vag (lb)	Jx1000 (in ⁴)	Cw (in ⁶)	Xo (in)	Ro (in)	β Beta	
162PDT125-15	0.0158	50	0.065	0.22	0.034	0.717	0.011	0.412	0.020	0.021	0.016	464	222	0.00542	0.006	-0.881	1.208	0.468	
250PDT125-15	0.0158	50	0.079	0.27	0.085	1.038	0.013	0.400	0.020	0.059	0.024	724	143	0.00657	0.015	-0.771	1.353	0.675	
362PDT125-15 ¹	0.0158	50	0.097	0.33	0.196	1.425	0.014	0.381	0.021	0.125	0.035	1059	98	0.00805	0.034	-0.668	1.619	0.830	
400PDT125-15 ¹	0.0158	50	0.103	0.35	0.247	1.550	0.014	0.374	0.021	0.153	0.039	1171	89	0.00854	0.043	-0.640	1.718	0.861	
600PDT125-15 ²	0.0158	50	0.134	0.46	0.646	2.194	0.016	0.343	0.021	0.350	0.059	1762	59	0.01117	0.108	-0.524	2.282	0.947	
162PDT200-15	0.0158	50	0.089	0.30	0.050	0.752	0.039	0.663	0.020	0.025	0.015	455	222	0.00739	0.020	-1.579	1.870	0.287	
250PDT200-15	0.0158	50	0.103	0.35	0.124	1.098	0.045	0.662	0.021	0.064	0.024	720	143	0.00854	0.052	-1.431	1.921	0.445	
362PDT200-15 ¹	0.0158	50	0.120	0.41	0.277	1.516	0.051	0.648	0.021	0.137	0.036	1063	98	0.01002	0.120	-1.282	2.088	0.623	
400PDT200-15 ¹	0.0158	50	0.126	0.43	0.344	1.650	0.052	0.642	0.021	0.168	0.039	1178	89	0.01052	0.151	-1.240	2.162	0.671	
600PDT200-15 ²	0.0158	50	0.158	0.54	0.864	2.338	0.058	0.608	0.021	0.389	0.060	1789	59	0.01315	0.383	-1.058	2.638	0.839	
162PDT250-15	0.0158	50	0.105	0.36	0.061	0.766	0.071	0.824	0.020	0.027	0.015	455	222	0.00871	0.038	-2.058	2.345	0.230	
250PDT250-15	0.0158	50	0.118	0.40	0.150	1.123	0.082	0.831	0.021	0.066	0.024	725	143	0.00986	0.096	-1.892	2.352	0.353	
362PDT250-15 ¹	0.0158	50	0.136	0.46	0.330	1.557	0.092	0.823	0.021	0.142	0.036	1073	98	0.01134	0.220	-1.720	2.462	0.512	
400PDT250-15 ¹	0.0158	50	0.142	0.48	0.409	1.696	0.095	0.819	0.021	0.174	0.040	1189	89	0.01183	0.275	-1.670	2.517	0.560	
600PDT250-15 ²	0.0158	50	0.174	0.59	1.009	2.409	0.108	0.787	0.021	0.404	0.060	1809	59	0.01446	0.697	-1.452	2.921	0.753	

Notes:

- Calculated properties are based on AISI S100-07, North American Specification for Design of Cold-Formed Steel Structural Members and AISI S220-11, North American Standard for Cold-Formed Steel Framing—Nonstructural Members.
 - Effective properties incorporate the strength increase from the cold work of forming as applicable per AISI A7.2.
 - Tabulated gross properties, including torsional properties, are based on full-unreduced cross section of the studs, away from punchouts.
 - Tabulated gross properties, including torsional properties, are based on full-unreduced cross section of the tracks.
 - For deflection calculations, use the effective moment of inertia.
 - Allowable moment includes cold work of forming.
 - Allowable moment is taken as the lowest value based on local or distortional buckling. Distortional buckling strength is based on a $k\text{-}\phi = 0$.
 - Web depth for track sections is equal to the nominal height plus two times the design thickness plus the bend radius. Hems on nonstructural track sections are ignored.
- 1 Web-height to thickness ratio exceeds 200. Web stiffeners are required at bearing points.
 - 2 Web-height to thickness ratio exceeds 260. Web stiffeners are required at bearing and intermediate points.

ProSTUD® 20 DRYWALL STUD

ClarkDietrich ProSTUD 20 (19mil) physical and structural properties

Member	Design thickness (in)	Fy (ksi)	Gross Section Properties						Effective Section Properties at Fy						Torsional Properties					Lu (in)
			Area (in ²)	Weight (lb/ft)	Ix (in ⁴)	Rx (in)	Iy (in ⁴)	Ry (in)	Ae (in ²)	Ix (in ⁴)	Sx (in ³)	Ma (in-lbs)	Vag (lb)	Vanet (lb)	Jx1000 (in ⁴)	Cw (in ⁶)	Xo (in)	Ro (in)	β Beta	
162PDS125-19	0.0200	65	0.090	0.31	0.042	0.685	0.020	0.466	0.042	0.037	0.031	1193	473	165	0.01197	0.012	-1.096	1.374	0.364	22.0
250PDS125-19	0.0200	65	0.109	0.37	0.112	1.017	0.024	0.467	0.046	0.104	0.061	2110	299	226	0.01449	0.032	-0.992	1.495	0.560	22.2
362PDS125-19	0.0200	65	0.132	0.45	0.266	1.420	0.027	0.454	0.048	0.254	0.080	3103	203	189	0.01757	0.072	-0.876	1.729	0.743	22.1
400PDS125-19	0.0200	65	0.140	0.48	0.336	1.550	0.028	0.451	0.050	0.316	0.091	3537	184	184	0.01865	0.092	-0.851	1.825	0.783	22.2
600PDS125-19 ²	0.0200	65	0.181	0.62	0.892	2.220	0.033	0.425	0.051	0.727	0.158	5421	121	121	0.02414	0.236	-0.723	2.373	0.907	21.9

ProTRAK® 20 DRYWALL TRACK

ClarkDietrich ProTRAK 20 (19mil) physical and structural properties

Member	Design thickness (in)	Fy (ksi)	Gross Section Properties						Effective Section Properties at Fy						Torsional Properties				
			Area (in ²)	Weight (lb/ft)	Ix (in ⁴)	Rx (in)	Iy (in ⁴)	Ry (in)	Ae (in ²)	Ix (in ⁴)	Sx (in ³)	Ma (in-lbs)	Vag (lb)	Jx1000 (in ⁴)	Cw (in ⁶)	Xo (in)	Ro (in)	β Beta	
162PDT125-19	0.0200	50	0.082	0.28	0.043	0.719	0.014	0.411	0.031	0.028	0.024	718	421	0.01099	0.007	-0.879	1.207	0.470	
250PDT125-19	0.0200	50	0.100	0.34	0.108	1.039	0.016	0.400	0.032	0.078	0.038	1136	289	0.01333	0.018	-0.769	1.353	0.677	
362PDT125-19	0.0200	50	0.122	0.42	0.249	1.426	0.018	0.380	0.032	0.191	0.055	1650	199	0.01633	0.043	-0.666	1.619	0.831	
400PDT125-19	0.0200	50	0.130	0.44	0.312	1.551	0.018	0.374	0.032	0.232	0.061	1822	180	0.01733	0.054	-0.638	1.718	0.862	
600PDT125-19 ²	0.0200	50	0.170	0.58	0.819	2.195	0.020	0.342	0.032	0.508	0.091	2717	119	0.02266	0.137	-0.523	2.282	0.948	
162PDT200-19	0.0200	50	0.112	0.38	0.064	0.754	0.049	0.662	0.031	0.034	0.024	707	421	0.01499	0.026	-1.576	1.868	0.288	
250PDT200-19	0.0200	50	0.130	0.44	0.157	1.099	0.057	0.661	0.032	0.094	0.037	1119	289	0.01733	0.066	-1.429	1.920	0.446	
362PDT200-19	0.0200	50	0.152	0.52	0.351	1.517	0.064	0.647	0.032	0.205	0.055	1651	199	0.02033	0.152	-1.280	2.088	0.624	
400PDT200-19	0.0200	50	0.160	0.54	0.436	1.651	0.066	0.642	0.032	0.251	0.061	1829	180	0.02133	0.191	-1.238	2.161	0.672	
600PDT200-19 ²	0.0200	50	0.200	0.68	1.094	2.339	0.074	0.607	0.033	0.580	0.093	2780	119	0.02666	0.485	-1.056	2.637	0.840	
162PDT250-19	0.0200	50	0.132	0.45	0.078	0.768	0.090	0.823	0.031	0.037	0.023	698	421	0.01766	0.048	-2.055	2.343	0.231	
250PDT250-19	0.0200	50	0.150	0.51	0.190	1.125	0.103	0.830	0.032	0.099	0.037	1113	289	0.01999	0.121	-1.890	2.351	0.354	
362PDT250-19	0.0200	50	0.172	0.59	0.419	1.558	0.117	0.822	0.032	0.213	0.055	1649	199	0.02299	0.278	-1.718	2.461	0.513	
400PDT250-19	0.0200	50	0.180	0.61	0.518	1.697	0.120	0.818	0.032	0.261	0.061	1829	180	0.02399	0.348	-1.668	2.517	0.561	
600PDT250-19 ²	0.0200	50	0.220	0.75	1.278	2.410	0.136	0.786	0.033	0.605	0.093	2788	119	0.02933	0.881	-1.450	2.920	0.754	

Notes:

- Calculated properties are based on AISI S100-07, North American Specification for Design of Cold-Formed Steel Structural Members and AISI S220-11, North American Standard for Cold-Formed Steel Framing—Nonstructural Members.
 - Effective properties incorporate the strength increase from the cold work of forming as applicable per AISI A7.2.
 - Tabulated gross properties, including torsional properties, are based on full-unreduced cross section of the studs, away from punchouts.
 - Tabulated gross properties, including torsional properties, are based on full-unreduced cross section of the tracks.
 - For deflection calculations, use the effective moment of inertia.
 - Allowable moment includes cold work of forming.
 - Allowable moment is taken as the lowest value based on local or distortional buckling. Distortional buckling strength is based on a k-phi = 0.
 - Web depth for track sections is equal to the nominal height plus two times the design thickness plus the bend radius. Hems on nonstructural track sections are ignored.
- 1 Web-height to thickness ratio exceeds 200. Web stiffeners are required at bearing points.
 - 2 Web-height to thickness ratio exceeds 260. Web stiffeners are required at bearing and intermediate points.

ProSTUD® 30MIL DRYWALL STUD
 (AVAILABLE IN SELECT MARKETS)

ClarkDietrich ProSTUD 30MIL physical and structural properties

Member	Design thickness (in)	Fy (ksi)	Gross Section Properties						Effective Section Properties at Fy						Torsional Properties					Lu (in)
			Area (in ²)	Weight (lb/ft)	Ix (in ⁴)	Rx (in)	Iy (in ⁴)	Ry (in)	Ae (in ²)	Ix (in ⁴)	Sx (in ³)	Ma (in-lbs)	Vag (lb)	Vanet (lb)	J* 1000 (in ⁴)	Cw (in ⁶)	Xo (in)	Ro (in)	β Beta	
162PDS125-30	0.0312	33	0.137	0.47	0.064	0.681	0.029	0.458	0.098	0.064	0.067	1332	572	124	0.04459	0.017	-1.070	1.348	0.371	30.8
250PDS125-30	0.0312	33	0.165	0.56	0.169	1.012	0.034	0.451	0.106	0.168	0.121	2356	832	397	0.05345	0.042	-0.941	1.454	0.581	30.1
362PDS125-30	0.0312	33	0.200	0.68	0.398	1.411	0.038	0.434	0.107	0.396	0.170	3358	776	457	0.06484	0.096	-0.820	1.689	0.764	29.7
400PDS125-30	0.0312	33	0.212	0.72	0.501	1.540	0.039	0.428	0.108	0.499	0.189	3737	701	490	0.06864	0.120	-0.787	1.781	0.805	29.5
600PDS125-30	0.0312	33	0.274	0.93	1.324	2.199	0.043	0.396	0.109	1.281	0.338	6031	461	461	0.08888	0.303	-0.651	2.327	0.922	28.7

ProTRAK® 30MIL DRYWALL TRACK
ClarkDietrich ProTRAK 30MIL physical and structural properties

Member	Design thickness (in)	Fy (ksi)	Gross Section Properties						Effective Section Properties at Fy						Torsional Properties				
			Area (in ²)	Weight (lb/ft)	Ix (in ⁴)	Rx (in)	Iy (in ⁴)	Ry (in)	Ae (in ²)	Ix (in ⁴)	Sx (in ³)	Ma (in-lbs)	Vag (lb)	J* 1000 (in ⁴)	Cw (in ⁶)	Xo (in)	Ro (in)	β Beta	
162PDT125-30	0.0312	33	0.128	0.44	0.067	0.722	0.022	0.409	0.080	0.054	0.048	951	610	0.04168	0.011	-0.872	1.204	0.475	
250PDT125-30	0.0312	33	0.156	0.53	0.169	1.042	0.025	0.397	0.084	0.140	0.087	1713	832	0.05054	0.029	-0.763	1.351	0.681	
362PDT125-30	0.0312	33	0.191	0.65	0.389	1.428	0.027	0.378	0.087	0.330	0.149	2938	755	0.06193	0.067	-0.661	1.619	0.833	
400PDT125-30	0.0312	33	0.203	0.69	0.489	1.553	0.028	0.371	0.088	0.417	0.172	3407	683	0.06573	0.084	-0.633	1.718	0.864	
600PDT125-30	0.0312	33	0.265	0.90	1.278	2.196	0.031	0.340	0.090	1.074	0.240	4737	454	0.08597	0.212	-0.519	2.282	0.948	
162PDT200-30	0.0312	33	0.175	0.60	0.101	0.758	0.076	0.660	0.081	0.067	0.052	1028	610	0.05687	0.040	-1.570	1.864	0.291	
250PDT200-30	0.0312	33	0.203	0.69	0.246	1.103	0.088	0.659	0.086	0.170	0.094	1862	832	0.06573	0.103	-1.423	1.917	0.449	
362PDT200-30	0.0312	33	0.238	0.81	0.549	1.520	0.099	0.645	0.089	0.397	0.160	3159	755	0.07712	0.237	-1.274	2.086	0.627	
400PDT200-30	0.0312	33	0.249	0.85	0.682	1.654	0.102	0.639	0.089	0.502	0.176	3480	683	0.08091	0.297	-1.232	2.160	0.674	
600PDT200-30	0.0312	33	0.312	1.06	1.710	2.342	0.114	0.605	0.091	1.353	0.262	5170	454	0.10116	0.754	-1.051	2.637	0.841	
162PDT250-30	0.0312	33	0.206	0.70	0.123	0.772	0.139	0.821	0.082	0.073	0.054	1059	610	0.06699	0.075	-2.048	2.338	0.233	
250PDT250-30	0.0312	33	0.234	0.80	0.298	1.129	0.160	0.828	0.086	0.186	0.097	1926	832	0.07585	0.190	-1.883	2.347	0.356	
362PDT250-30	0.0312	33	0.269	0.92	0.656	1.562	0.181	0.820	0.089	0.436	0.157	3097	755	0.08724	0.435	-1.712	2.458	0.515	
400PDT250-30	0.0312	33	0.281	0.96	0.812	1.701	0.187	0.816	0.090	0.551	0.173	3425	683	0.09104	0.543	-1.662	2.514	0.563	
600PDT250-30	0.0312	33	0.343	1.17	1.997	2.413	0.211	0.784	0.092	1.473	0.261	5162	454	0.11128	1.373	-1.444	2.919	0.755	

Notes:

- Calculated properties are based on AISI S100-07, North American Specification for Design of Cold-Formed Steel Structural Members and AISI S220-11, North American Standard for Cold-Formed Steel Framing—Nonstructural Members.
 - Effective properties incorporate the strength increase from the cold work of forming as applicable per AISI A7.2.
 - Tabulated gross properties, including torsional properties, are based on full-unreduced cross section of the studs, away from punchouts.
 - Tabulated gross properties, including torsional properties, are based on full-unreduced cross section of the tracks.
 - For deflection calculations, use the effective moment of inertia.
 - Allowable moment includes cold work of forming.
 - Allowable moment is taken as the lowest value based on local or distortional buckling. Distortional buckling strength is based on a $k\text{-}\phi = 0$.
 - Web depth for track sections is equal to the nominal height plus two times the design thickness plus the bend radius. Hems on nonstructural track sections are ignored.
- 1 Web-height to thickness ratio exceeds 200. Web stiffeners are required at bearing points.
 - 2 Web-height to thickness ratio exceeds 260. Web stiffeners are required at bearing and intermediate points.

ProSTUD® 33MIL DRYWALL STUD
(AVAILABLE IN SELECT MARKETS)

ClarkDietrich ProSTUD 33MIL physical and structural properties

Member	Design thickness (in)	Fy (ksi)	Gross Section Properties						Effective Section Properties at Fy						Torsional Properties					Lu (in)
			Area (in ²)	Weight (lb/ft)	Ix (in ⁴)	Rx (in)	Iy (in ⁴)	Ry (in)	Ae (in ²)	Ix (in ⁴)	Sx (in ³)	Ma (in-lbs)	Vag (lb)	Vanet (lb)	J* 1000 (in ⁴)	Cw (in ⁶)	Xo (in)	Ro (in)	β Beta	
162PDS125-33	0.0346	33	0.152	0.52	0.070	0.679	0.032	0.456	0.114	0.070	0.078	1541	632	123	0.06059	0.019	-1.065	1.344	0.371	30.8
250PDS125-33	0.0346	33	0.182	0.62	0.186	1.010	0.037	0.449	0.125	0.186	0.138	2697	1007	431	0.07267	0.046	-0.937	1.449	0.582	30.1
362PDS125-33	0.0346	33	0.221	0.75	0.439	1.409	0.041	0.433	0.127	0.439	0.200	3943	1024	541	0.08820	0.106	-0.816	1.685	0.766	29.6
400PDS125-33	0.0346	33	0.234	0.80	0.553	1.538	0.043	0.426	0.128	0.553	0.222	4394	957	602	0.09338	0.132	-0.783	1.777	0.806	29.5
600PDS125-33	0.0346	33	0.303	1.03	1.463	2.196	0.047	0.394	0.130	1.428	0.399	7021	630	630	0.12100	0.332	-0.647	2.323	0.922	28.6

ProTRAK® 33MIL DRYWALL TRACK

ClarkDietrich ProTRAK 33MIL physical and structural properties

Member	Design thickness (in)	Fy (ksi)	Gross Section Properties						Effective Section Properties at Fy						Torsional Properties				
			Area (in ²)	Weight (lb/ft)	Ix (in ⁴)	Rx (in)	Iy (in ⁴)	Ry (in)	Ae (in ²)	Ix (in ⁴)	Sx (in ³)	Ma (in-lbs)	Vag (lb)	J* 1000 (in ⁴)	Cw (in ⁶)	Xo (in)	Ro (in)	β Beta	
162PDT125-33	0.0346	33	0.142	0.48	0.075	0.723	0.024	0.409	0.095	0.063	0.056	1104	677	0.05683	0.012	-0.870	1.203	0.477	
250PDT125-33	0.0346	33	0.173	0.59	0.188	1.043	0.027	0.397	0.102	0.160	0.100	1972	1024	0.06891	0.032	-0.762	1.351	0.682	
362PDT125-33	0.0346	33	0.212	0.72	0.432	1.429	0.030	0.377	0.105	0.375	0.170	3358	1024	0.08444	0.074	-0.659	1.618	0.834	
400PDT125-33	0.0346	33	0.225	0.77	0.542	1.554	0.031	0.371	0.106	0.473	0.197	3887	931	0.08962	0.093	-0.632	1.718	0.865	
600PDT125-33	0.0346	33	0.294	1.00	1.418	2.197	0.034	0.339	0.109	1.237	0.287	5681	619	0.11723	0.234	-0.517	2.282	0.949	
162PDT200-33	0.0346	33	0.194	0.66	0.112	0.759	0.085	0.660	0.097	0.077	0.061	1198	677	0.07754	0.045	-1.568	1.862	0.292	
250PDT200-33	0.0346	33	0.225	0.77	0.274	1.104	0.097	0.658	0.104	0.196	0.109	2150	1024	0.08962	0.114	-1.421	1.916	0.450	
362PDT200-33	0.0346	33	0.264	0.90	0.610	1.521	0.110	0.645	0.107	0.452	0.186	3669	1024	0.10515	0.263	-1.272	2.085	0.628	
400PDT200-33	0.0346	33	0.276	0.94	0.758	1.655	0.113	0.639	0.108	0.567	0.215	4246	931	0.11033	0.329	-1.230	2.159	0.675	
600PDT200-33	0.0346	33	0.346	1.18	1.897	2.342	0.126	0.604	0.111	1.520	0.322	6355	619	0.13795	0.835	-1.050	2.637	0.842	
162PDT250-33	0.0346	33	0.229	0.78	0.137	0.774	0.154	0.821	0.098	0.085	0.063	1235	677	0.09135	0.083	-2.046	2.336	0.233	
250PDT250-33	0.0346	33	0.259	0.88	0.331	1.130	0.177	0.827	0.104	0.214	0.113	2225	1024	0.10343	0.211	-1.881	2.346	0.357	
362PDT250-33	0.0346	33	0.298	1.01	0.728	1.563	0.200	0.820	0.108	0.493	0.193	3808	1024	0.11896	0.482	-1.710	2.457	0.516	
400PDT250-33	0.0346	33	0.311	1.06	0.901	1.702	0.207	0.815	0.109	0.622	0.214	4221	931	0.12414	0.602	-1.660	2.514	0.564	
600PDT250-33	0.0346	33	0.380	1.29	2.216	2.414	0.233	0.783	0.111	1.657	0.320	6327	619	0.15175	1.522	-1.443	2.919	0.756	

Notes:

- Calculated properties are based on AISI S100-07, North American Specification for Design of Cold-Formed Steel Structural Members and AISI S220-11, North American Standard for Cold-Formed Steel Framing—Nonstructural Members.
 - Effective properties incorporate the strength increase from the cold work of forming as applicable per AISI A7.2.
 - Tabulated gross properties, including torsional properties, are based on full-unreduced cross section of the studs, away from punchouts.
 - Tabulated gross properties, including torsional properties, are based on full-unreduced cross section of the tracks.
 - For deflection calculations, use the effective moment of inertia.
 - Allowable moment includes cold work of forming.
 - Allowable moment is taken as the lowest value based on local or distortional buckling. Distortional buckling strength is based on a k-phi = 0.
 - Web depth for track sections is equal to the nominal height plus two times the design thickness plus the bend radius. Hems on nonstructural track sections are ignored.
- 1 Web-height to thickness ratio exceeds 200. Web stiffeners are required at bearing points.
 - 2 Web-height to thickness ratio exceeds 260. Web stiffeners are required at bearing and intermediate points.

ALLOWABLE SCREW DESIGN VALUES (LBS)

Member designation	Thickness (mils)	Design thickness (in)	Yield (ksi)	Ultimate	#6 Screw (0.138" Dia., 5/16" Head)			#8 Screw (0.164" Dia., 5/16" Head)			#10 Screw (0.190" Dia., 0.34" Head)					
					Shear, lbs	1-Side	2-Side	Pullout, lbs	Shear, lbs	1-Side	2-Side	Pullout, lbs	Shear, lbs	1-Side	2-Side	Pullout, lbs
PDS125-15	15	0.0158	50	50	52	62	123	31	56	62	123	37	61	67	134	43
PDS125-19	19	0.0200	65	65	96	102	203	51	104	102	203	60	112	111	221	70
PDS125-30	30	0.0312	33	33	95	80	161	40	103	80	161	48	111	88	175	55
PDS125-33	33	0.0346	33	45	151	122	243	61	164	122	243	72	177	132	265	84

Notes:

- Allowable screw connection capacities are based on Section E4 of the AISI S100-07 Specification.
- When connecting materials of different steel thicknesses or tensile strengths, use the lowest values. Tabulated values assume two sheets of equal thickness are connected.
- Screw shear and tension capacities were developed using published screw manufacturer data and evaluation reports available at the time of publication.
- Screw capacities are based on Allowable Strength Design (ASD) and include a safety factor of 3.0.
- When multiple fasteners are used, screws are assumed to have a center-to-center spacing of at least three times the nominal diameter (d).
- Screws are assumed to have a center-of-screw to edge-of-steel dimension of at least 1-1/2 times the nominal diameter (d) of the screw.
- Tension capacity is based on the lesser of pullout capacity in sheet closest to screw tip, or pullover capacity for sheet closest to screw head (using head diameter).
- Screw capacities are governed by a conservative estimate of screw capacity, not by sheet steel failure.
- For higher screw capacities, especially for screw strength, use specific screws from specific manufacturer. See manufacturer's data for specific allowable values and installation instructions.

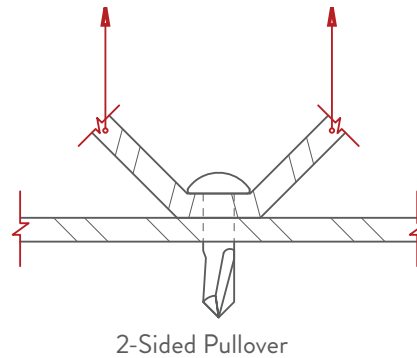
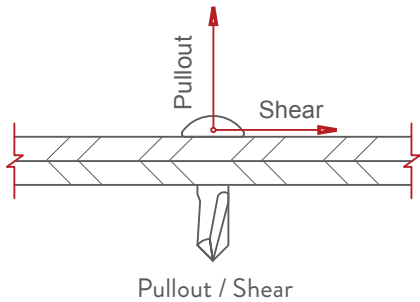

ProSTUD® WITH HIGH-IMPACT AND HIGH-ABUSE BOARDS



The following drywall manufacturers conducted their own internal tests using ProSTUD Drywall Framing products with their High-Impact, Abuse and Tile Backer boards. You can find independent approval letters at clarkdietrich.com.

- CertainTeed: GlasRoc® Tile Backer & ProRoc Extra AB with ProSTUD 20
- G-P: DensShield-DensAmor® AR and IR with ProSTUD 20
- National: Hi-Abuse® XP with ProSTUD 20
- Temple Inland: ComfortGuard® AR and IR with ProSTUD 20
- FIBEROCK® AR with ProSTUD 20

WHICH ProSTUD® LIMITING HEIGHTS TABLE SHOULD I USE?

ProSTUD, like any interior drywall stud, may be used in a variety of applications including walls, ceilings, and soffits. While some conditions may require the expertise of a design professional, many assemblies can be selected based on tabulated data. Using the diagrams below, locate the required assembly and follow the instructions for selecting the proper ProSTUD member.

Composite Assemblies

Composite limiting height data can be applied to walls where gypsum board is installed on both flanges of the stud for the full height of the wall. ProSTUD composite data is based on the 2003, 2006, 2009 and 2012 International Building Code, and was tested and analyzed in accordance with the most recent version of AC86 (2010). Composite limiting height tables for ProSTUD members are available starting on page 10 of this catalog. In addition, a comprehensive offering is available at clarkdietrich.com.

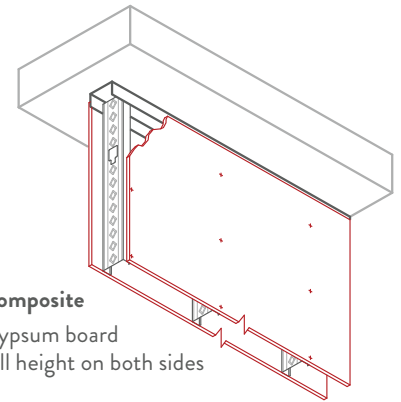

Composite
Gypsum board
full height on both sides

Non-Composite Assemblies

Non-composite conditions are common in all structures. When the gypsum board stops at the ceiling level, but the stud continues to the deck, it is a non-composite condition. While there may be advantages to contacting Technical Services or a Design Professional, many conditions can be covered by limiting heights tables shown in this catalog or at clarkdietrich.com. When in doubt, call our complimentary Technical Services Hotline at 888-437-3244.

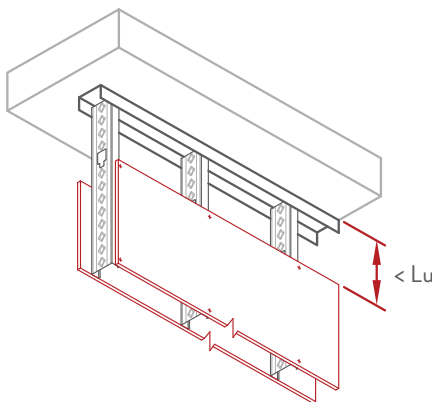

**Non-Composite
FULLY BRACED**
Unbraced length is less than Lu

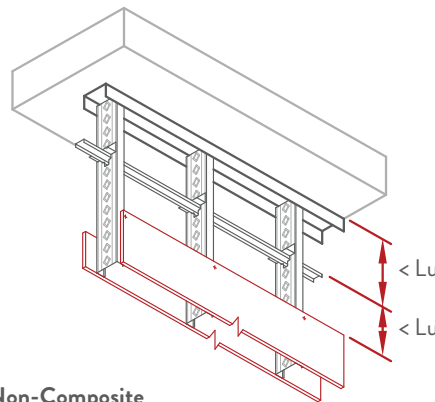

**Non-Composite
FULLY BRACED**
Bracing spacing above
gypsum is less than Lu

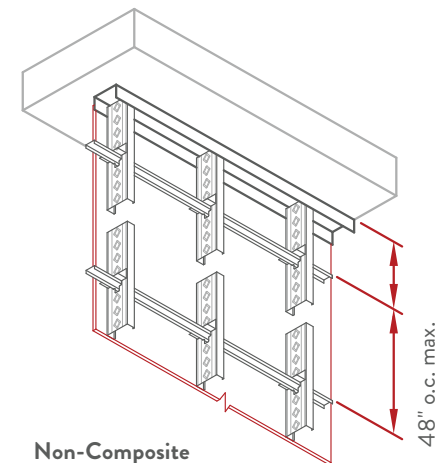

**Non-Composite
BRACED AT 48" o.c.**
Gypsum board placed on only one side

Distance of unbraced length (Lu) can be found in the physical and structural properties starting on page 4.

Chase Walls or Furred Walls

Chase and furred walls are common, but the conditions vary greatly depending on the building requirements. While non-composite tables may be used conservatively, when in doubt, contact our Technical Services Hotline at 888-437-3244 for chase wall designs.

Ceilings

Interior ceilings are often supported by ProSTUD framing. The design criteria varies greatly based on the weight of the ceiling, bracing, and support points. You'll find a partial listing of ceiling span tables on page 18; visit clarkdietrich.com/ProSTUD for more comprehensive data.

ProSTUD® COMPOSITE LIMITING HEIGHTS

5/8" Type X Gypsum Board

Width (in)	Stud member	Design thickness (in)	Yield strength (ksi)	Spacing (inches)	Lateral Load (psf)								
					5psf			7.5psf			10psf		
					L/120	L/240	L/360	L/120	L/240	L/360	L/120	L/240	L/360
1-5/8	ProSTUD 25 162PDS125-15	0.0158	50	12	14' 1"	11' 7"	10' 1"	12' 3"	10' 1"	8' 7"	11' 2"	9' 1"	—
				16	12' 9"	10' 6"	9' 0"	11' 2"	9' 1"	—	10' 2"	8' 1"	—
				24	11' 2"	9' 1"	—	9' 9"	—	—	8' 5"	—	—
	ProSTUD 20 162PDS125-19	0.0200	65	12	14' 10"	12' 11"	11' 2"	12' 11"	11' 3"	9' 9"	11' 9"	10' 3"	8' 8"
				16	13' 5"	11' 8"	10' 1"	11' 9"	10' 3"	8' 8"	10' 8"	9' 2"	—
				24	11' 9"	10' 3"	8' 8"	10' 3"	8' 8"	—	9' 2"	—	—
	ProSTUD 30 162PDS125-30	0.0312	33	12	16' 3"	12' 11"	11' 3"	14' 3"	11' 3"	9' 10"	12' 11"	10' 3"	8' 8"
				16	14' 9"	11' 9"	10' 3"	12' 11"	10' 3"	8' 8"	11' 9"	9' 2"	—
				24	12' 11"	10' 3"	8' 8"	11' 3"	8' 8"	—	10' 3"	—	—
	ProSTUD 33 162PDS125-33	0.0346	33	12	17' 0"	13' 6"	11' 10"	14' 10"	11' 10"	10' 4"	13' 6"	10' 9"	9' 3"
				16	15' 6"	12' 3"	10' 9"	13' 6"	10' 9"	9' 3"	12' 3"	9' 9"	—
				24	13' 6"	10' 9"	9' 3"	11' 10"	9' 3"	—	10' 9"	—	—
2-1/2	ProSTUD 25 250PDS125-15	0.0158	50	12	17' 2"	14' 8"	13' 0"	15' 0"	12' 10"	11' 4"	13' 3" f	11' 8"	10' 4"
				16	15' 7"	13' 4"	11' 9"	13' 3" f	11' 8"	10' 4"	11' 5" f	10' 7"	9' 1"
				24	13' 3" f	11' 8"	10' 4"	10' 10" f	10' 2"	8' 6"	9' 4" f	8' 11"	—
	ProSTUD 20 250PDS125-19	0.0200	65	12	18' 1"	15' 9"	14' 0"	15' 9"	13' 9"	12' 3"	14' 4"	12' 6"	11' 1"
				16	16' 5"	14' 4"	12' 8"	14' 4"	12' 6"	11' 1"	13' 0"	12' 6"	10' 1"
				24	14' 4"	12' 6"	11' 1"	12' 6" f	10' 11"	9' 8"	11' 5"	9' 11"	8' 7"
	ProSTUD 30 250PDS125-30	0.0312	33	12	19' 9"	16' 3"	14' 4"	17' 3"	14' 2"	12' 6"	15' 8"	12' 11"	11' 4"
				16	17' 11"	14' 9"	13' 0"	15' 8"	12' 11"	11' 4"	14' 3"	11' 9"	10' 4"
				24	15' 8"	12' 11"	11' 4"	13' 8" f	11' 3"	9' 11"	12' 5"	10' 3"	8' 8"
	ProSTUD 33 250PDS125-33	0.0346	33	12	20' 4"	16' 9"	14' 9"	17' 9"	14' 7"	12' 10"	16' 2"	13' 3"	11' 8"
				16	18' 6"	15' 2"	13' 5"	16' 2"	13' 3"	11' 8"	14' 8"	12' 1"	10' 7"
				24	16' 2"	13' 3"	11' 8"	14' 1"	11' 7"	10' 3"	12' 10"	10' 7"	9' 1"
3-5/8	ProSTUD 25 362PDS125-15	0.0158	50	12	21' 6"	17' 1"	14' 11"	18' 4" f	14' 11"	13' 0"	15' 10" f	13' 7"	11' 10"
				16	19' 5" f	15' 6"	13' 7"	15' 10" f	13' 7"	11' 10"	13' 9" f	12' 4"	10' 7"
				24	15' 10" f	13' 7"	11' 10"	12' 11" f	11' 10"	10' 1"	11' 2" f	10' 7"	9' 0"
	ProSTUD 20 362PDS125-19	0.0200	65	12	23' 3"	18' 5"	16' 1"	20' 4"	16' 1"	14' 1"	18' 5"	14' 8"	12' 10"
				16	21' 1"	16' 9"	14' 8"	18' 5"	14' 8"	12' 10"	16' 7" f	13' 4"	11' 7"
				24	18' 5"	14' 8"	12' 10"	15' 8" f	12' 10"	11' 1"	13' 7" f	11' 7"	9' 11"
	ProSTUD 30 362PDS125-30	0.0312	33	12	25' 8"	20' 5"	17' 10"	22' 5"	17' 10"	15' 7"	20' 5"	16' 2"	14' 2"
				16	23' 4"	18' 6"	16' 2"	20' 5"	16' 2"	14' 2"	18' 6"	14' 8"	12' 10"
				24	20' 5"	16' 2"	14' 2"	17' 10"	14' 2"	12' 3"	16' 2"	12' 10"	11' 0"
	ProSTUD 33 362PDS125-33	0.0346	33	12	26' 7"	21' 2"	18' 5"	23' 3"	18' 5"	16' 1"	21' 2"	16' 9"	14' 8"
				16	24' 2"	19' 2"	16' 9"	21' 2"	16' 9"	14' 8"	19' 2"	15' 3"	13' 4"
				24	21' 2"	16' 9"	14' 8"	18' 5"	14' 8"	12' 10"	16' 9"	13' 4"	11' 6"

Notes:

- Allowable composite limiting heights were determined in accordance with ICC-ES AC86-2010.
- Additional composite wall testing and analysis requirements of the SFIA Code Compliance Certification Program were observed.
- In accordance with current building codes and AISI design standards, the 1/3 stress increase for strength was not used.
- The composite limiting heights provided in the tables are based on a single layer of 5/8" Type X Gypsum Board from the following manufacturers: American, CertainTeed, Georgia Pacific, Lafarge, National, Temple Inland, and USG.
- The gypsum board must be applied full height in the vertical orientation to each stud flange and installed in accordance with ASTM C754-2008 using minimum No. 6 Type S drywall screws spaced as listed below:
 - Screws spaced a minimum of 16 in. o.c. to framing members spaced at 16 in. or 12 in. o.c.
 - Screws spaced a minimum of 12 in. o.c. to framing members spaced at 24 in. o.c.
- No fasteners are required for attaching the stud to the track except as detailed in ASTM C754-2008.
- Stud end bearing must be a minimum of 1 inch.
- f** Adjacent to the height value indicates that flexural stress controls the allowable wall height.
- s** Adjacent to the height value indicates that shear/end reaction controls the allowable wall height.

ProSTUD® COMPOSITE LIMITING HEIGHTS

5/8" Type X Gypsum Board

Width (in)	Stud member	Design thickness (in)	Yield strength (ksi)	Spacing (inches)	Lateral Load (psf)								
					5psf			7.5psf			10psf		
					L/120	L/240	L/360	L/120	L/240	L/360	L/120	L/240	L/360
4	ProSTUD 25 400PDS125-15	0.0158	50	12	22' 8"	18' 0"	15' 9"	19' 1" f	15' 9"	13' 9"	16' 6" f	14' 4"	12' 6"
				16	20' 3" f	16' 4"	14' 4"	16' 6" f	14' 4"	12' 6"	14' 4" f	13' 0"	11' 3"
				24	16' 6" f	14' 4"	12' 6"	13' 6" f	12' 6"	10' 8"	11' 8" f	11' 3"	9' 6"
	ProSTUD 20 400PDS125-19	0.0200	65	12	24' 4"	20' 2"	17' 9"	21' 3"	17' 8"	15' 6"	19' 4"	16' 0"	14' 1"
				16	22' 2"	18' 4"	16' 1"	19' 4"	16' 0"	14' 1"	17' 7" f	14' 7"	12' 9"
				24	19' 4"	16' 0"	14' 1"	16' 6" f	14' 0"	12' 4"	14' 4" f	12' 9"	11' 0"
	ProSTUD 30 400PDS125-30	0.0312	33	12	27' 5"	21' 9"	19' 0"	24' 0"	19' 0"	16' 8"	21' 9"	17' 4"	15' 1"
				16	24' 11"	19' 10"	17' 4"	21' 9"	17' 4"	15' 1"	19' 10"	15' 9"	13' 9"
				24	21' 9"	17' 4"	15' 1"	19' 0"	15' 1"	13' 2"	17' 4"	13' 9"	11' 10"
	ProSTUD 33 400PDS125-33	0.0346	33	12	27' 10"	22' 9"	20' 1"	24' 3"	19' 11"	17' 7"	22' 1"	18' 1"	15' 11"
				16	25' 3"	20' 8"	18' 3"	22' 1"	18' 1"	15' 11"	20' 1"	16' 5"	14' 6"
				24	22' 1"	18' 1"	15' 11"	19' 3"	15' 10"	13' 11"	17' 6"	14' 4"	12' 8"
6	ProSTUD 25 600PDS125-15	0.0158	50	12	27' 10" f	24' 2"	21' 5"	22' 9" f	21' 1"	18' 8"	19' 8" f	19' 2"	17' 0"
				16	24' 1" f	21' 11"	19' 5"	19' 8" f	19' 2"	17' 0"	17' 1" f	17' 1" f	15' 5"
				24	19' 8" f	19' 2"	17' 0"	16' 1" f	16' 1" f	14' 9"	13' 11" f	13' 11" f	13' 4"
	ProSTUD 20 600PDS125-19	0.0200	65	12	32' 0"	26' 5"	23' 2"	28' 0"	23' 1"	20' 3"	24' 9" f	21' 0"	18' 5"
				16	29' 1"	24' 0"	21' 1"	24' 9" f	21' 0"	18' 5"	21' 5" f	19' 1"	16' 9"
				24	24' 9" f	21' 0"	18' 5"	20' 3" f	18' 4"	16' 1"	17' 6" f	16' 8"	14' 4"
	ProSTUD 30 600PDS125-30	0.0312	33	12	36' 7"	29' 1"	25' 5"	32' 0"	25' 5"	22' 2"	29' 1"	23' 1"	20' 2"
				16	33' 3"	26' 5"	23' 1"	29' 1"	23' 1"	20' 2"	26' 5"	20' 11"	18' 4"
				24	29' 1"	23' 1"	20' 2"	25' 5"	20' 2"	17' 7"	22' 6" f	18' 4"	—
	ProSTUD 33 600PDS125-33	0.0346	33	12	36' 8"	30' 1"	26' 6"	32' 0"	26' 3"	23' 2"	29' 1"	23' 10"	21' 0"
				16	33' 3"	27' 4"	24' 1"	29' 1"	23' 10"	21' 0"	26' 5"	21' 8"	19' 1"
				24	29' 1"	23' 10"	21' 0"	25' 5"	20' 10"	18' 4"	23' 1"	18' 11"	—

Notes:

- Allowable composite limiting heights were determined in accordance with ICC-ES AC86-2010.
- Additional composite wall testing and analysis requirements of the SFIA Code Compliance Certification Program were observed.
- In accordance with current building codes and AISI design standards, the 1/3 stress increase for strength was not used.
- The composite limiting heights provided in the tables are based on a single layer of 5/8" Type X Gypsum Board from the following manufacturers: American, CertainTeed, Georgia Pacific, Lafarge, National, Temple Inland, and USG.
- The gypsum board must be applied full height in the vertical orientation to each stud flange and installed in accordance with ASTM C754-2008 using minimum No. 6 Type S drywall screws spaced as listed below:
 - Screws spaced a minimum of 16 in. o.c. to framing members spaced at 16 in. or 12 in. o.c.
 - Screws spaced a minimum of 12 in. o.c. to framing members spaced at 24 in. o.c.
- No fasteners are required for attaching the stud to the track except as detailed in ASTM C754-2008.
- Stud end bearing must be a minimum of 1 inch.
- f** Adjacent to the height value indicates that flexural stress controls the allowable wall height.
- s** Adjacent to the height value indicates that shear/end reaction controls the allowable wall height.

ProSTUD® NON-COMPOSITE LIMITING HEIGHTS

ClarkDietrich ProSTUD Non-Composite Limiting Heights—FULLY BRACED

Depth (in)	Stud member	Design thickness (in)	Yield strength (ksi)	Spacing o.c. (in)	Lateral Load (psf)								
					5psf			7.5psf			10psf		
					L/120	L/240	L/360	L/120	L/240	L/360	L/120	L/240	L/360
1-5/8	ProSTUD 25 162PDS125-15	0.0158	50	12	9' 2"	7' 4"	6' 4"	8' 0"	6' 4"	5' 7"	6' 11"	5' 9"	5' 1"
		0.0158	50	16	8' 4"	6' 8"	5' 9"	6' 11"	5' 9"	5' 1"	6' 0"	5' 3"	4' 7"
		0.0158	50	24	6' 11"	5' 9"	5' 1"	5' 8"	5' 1"	4' 5"	4' 11"	4' 7"	4' 0"
	ProSTUD 20 162PDS125-19	0.0200	65	12	9' 11"	7' 10"	6' 10"	8' 8"	6' 10"	6' 0"	7' 10"	6' 3"	5' 5"
		0.0200	65	16	9' 0"	7' 2"	6' 3"	7' 10"	6' 3"	5' 5"	7' 2"	5' 8"	4' 11"
		0.0200	65	24	7' 10"	6' 3"	5' 5"	6' 10"	5' 5"	4' 9"	6' 3"	4' 11"	4' 4"
	ProSTUD 30MIL 162PDS125-30	0.0312	33	12	11' 10"	9' 5"	8' 3"	10' 4"	8' 3"	7' 2"	9' 5"	7' 6"	6' 6"
		0.0312	33	16	10' 9"	8' 7"	7' 6"	9' 5"	7' 6"	6' 6"	8' 2"	6' 9"	5' 11"
		0.0312	33	24	9' 5"	7' 6"	6' 6"	7' 8"	6' 6"	5' 8"	6' 8"	5' 11"	5' 2"
	ProSTUD 33MIL 162PDS125-33	0.0346	33	12	12' 3"	9' 9"	8' 6"	10' 8"	8' 6"	7' 5"	9' 9"	7' 9"	6' 9"
		0.0346	33	16	11' 2"	8' 10"	7' 9"	9' 9"	7' 9"	6' 9"	8' 9"	7' 0"	6' 1"
		0.0346	33	24	9' 9"	7' 9"	6' 9"	8' 3"	6' 9"	5' 11"	7' 2"	6' 1"	5' 4"
2-1/2	ProSTUD 25 250PDS125-15	0.0158	50	12	12' 8"	10' 2"	8' 11"	10' 4"	8' 11"	7' 9"	8' 11"	8' 1"	7' 1"
		0.0158	50	16	10' 11"	9' 3"	8' 1"	8' 11"	8' 1"	7' 1"	7' 9"	7' 4"	6' 5"
		0.0158	50	24	8' 11"	8' 1"	7' 1"	7' 4"	7' 1"	6' 2"	6' 4"	6' 4"	5' 7"
	ProSTUD 20 250PDS125-19	0.0200	65	12	14' 0"	11' 1"	9' 8"	12' 3"	9' 8"	8' 6"	11' 1"	8' 10"	7' 8"
		0.0200	65	16	12' 8"	10' 1"	8' 10"	11' 1"	8' 10"	7' 8"	10' 1"	8' 0"	7' 0"
		0.0200	65	24	11' 1"	8' 10"	7' 8"	9' 8"	7' 8"	6' 9"	8' 5"	7' 0"	6' 1"
	ProSTUD 30MIL 250PDS125-30	0.0312	33	12	16' 5"	13' 0"	11' 4"	14' 4"	11' 4"	9' 11"	12' 6"	10' 4"	9' 0"
		0.0312	33	16	14' 11"	11' 10"	10' 4"	12' 6"	10' 4"	9' 0"	10' 10"	9' 5"	8' 2"
		0.0312	33	24	12' 6"	10' 4"	9' 0"	10' 3"	9' 0"	7' 11"	8' 10"	8' 2"	7' 2"
	ProSTUD 33MIL 250PDS125-33	0.0346	33	12	16' 11"	13' 5"	11' 9"	14' 10"	11' 9"	10' 3"	13' 5"	10' 8"	9' 4"
		0.0346	33	16	15' 5"	12' 3"	10' 8"	13' 5"	10' 8"	9' 4"	11' 7"	9' 8"	8' 6"
		0.0346	33	24	13' 5"	10' 8"	9' 4"	10' 11"	9' 4"	8' 2"	9' 6"	8' 6"	7' 5"
3-5/8	ProSTUD 25 362PDS125-15 ¹	0.0158	50	12	15' 0"	13' 7"	11' 10"	12' 3"	11' 10"	10' 4"	10' 7"	10' 7"	9' 5"
		0.0158	50	16	13' 0"	12' 4"	10' 9"	10' 7"	10' 7"	9' 5"	7' 11"	7' 11"	7' 11"
		0.0158	50	24	10' 7"	10' 7"	9' 5"	7' 1"	7' 1"	7' 1"	5' 4"	5' 4"	5' 4"
	ProSTUD 20 362PDS125-19	0.0200	65	12	18' 10"	14' 11"	13' 0"	16' 5"	13' 0"	11' 5"	14' 5"	11' 10"	10' 4"
		0.0200	65	16	17' 1"	13' 7"	11' 10"	14' 5"	11' 10"	10' 4"	12' 5"	10' 9"	9' 5"
		0.0200	65	24	14' 5"	11' 10"	10' 4"	11' 9"	10' 4"	9' 0"	10' 2"	9' 5"	8' 3"
	ProSTUD 30MIL 362PDS125-30	0.0312	33	12	21' 2"	17' 4"	15' 2"	17' 3"	15' 2"	13' 3"	15' 0"	13' 9"	12' 0"
		0.0312	33	16	18' 4"	15' 9"	13' 9"	15' 0"	13' 9"	12' 0"	12' 11"	12' 6"	10' 11"
		0.0312	33	24	15' 0"	13' 9"	12' 0"	12' 3"	12' 0"	10' 6"	10' 7"	10' 7"	9' 6"
	ProSTUD 33MIL 362PDS125-33	0.0346	33	12	22' 7"	17' 11"	15' 8"	18' 9"	15' 8"	13' 8"	16' 3"	14' 3"	12' 5"
		0.0346	33	16	19' 10"	16' 3"	14' 3"	16' 3"	14' 3"	12' 5"	14' 0"	12' 11"	11' 3"
		0.0346	33	24	16' 3"	14' 3"	12' 5"	13' 3"	12' 5"	10' 10"	11' 6"	11' 3"	9' 10"
4	ProSTUD 25 400PDS125-15 ¹	0.0158	50	12	15' 9"	14' 6"	12' 8"	12' 6"	12' 6"	11' 1"	9' 4"	9' 4"	9' 4"
		0.0158	50	16	13' 8"	13' 2"	11' 6"	9' 4"	9' 4"	9' 4"	7' 0"	7' 0"	7' 0"
		0.0158	50	24	9' 4"	9' 4"	9' 4"	6' 3"	6' 3"	6' 3"	4' 8"	4' 8"	4' 8"
	ProSTUD 20 400PDS125-19	0.0200	65	12	20' 3"	16' 1"	14' 0"	17' 8"	14' 0"	12' 3"	15' 4"	12' 9"	11' 2"
		0.0200	65	16	18' 5"	14' 7"	12' 9"	15' 4"	12' 9"	11' 2"	13' 4"	11' 7"	10' 1"
		0.0200	65	24	15' 4"	12' 9"	11' 2"	12' 6"	11' 2"	9' 9"	10' 10"	10' 1"	8' 10"
	ProSTUD 30MIL 400PDS125-30	0.0312	33	12	22' 4"	18' 8"	16' 4"	18' 3"	16' 4"	14' 3"	15' 9"	14' 10"	13' 0"
		0.0312	33	16	19' 4"	17' 0"	14' 10"	15' 9"	14' 10"	13' 0"	13' 8"	13' 6"	11' 9"
		0.0312	33	24	15' 9"	14' 10"	13' 0"	12' 11"	12' 11"	11' 2"	11' 2"	11' 2"	10' 3"
	ProSTUD 33MIL 400PDS125-33	0.0346	33	12	24' 2"	19' 4"	16' 11"	19' 9"	16' 11"	14' 9"	17' 1"	15' 4"	13' 5"
		0.0346	33	16	21' 0"	17' 7"	15' 4"	17' 1"	15' 4"	13' 5"	14' 10"	13' 11"	12' 2"
		0.0346	33	24	17' 1"	15' 4"	13' 5"	14' 0"	13' 5"	11' 9"	12' 1"	12' 1"	10' 8"
6	ProSTUD 30MIL 600PDS125-30	0.0312	33	12	28' 4"	25' 7"	22' 4"	23' 2"	22' 4"	19' 7"	20' 1"	20' 1"	17' 9"
		0.0312	33	16	24' 7"	23' 3"	20' 4"	20' 1"	20' 1"	17' 9"	17' 4"	17' 4"	16' 2"
		0.0312	33	24	20' 1"	20' 1"	17' 9"	16' 4"	16' 4"	15' 6"	14' 2"	14' 2"	14' 1"
	ProSTUD 33MIL 600PDS125-33	0.0346	33	12	30' 7"	26' 7"	23' 2"	25' 0"	23' 2"	20' 3"	21' 8"	21' 1"	18' 5"
		0.0346	33	16	26' 6"	24' 1"	21' 1"	21' 8"	21' 1"	18' 5"	18' 9"	18' 9"	16' 9"
		0.0346	33	24	21' 8"	21' 1"	18' 5"	17' 8"	17' 8"	16' 1"	15' 4"	15' 4"	14' 7"

- Notes:**
- Heights are based on AISI S100-07, North American Specification and AISI S220-11, North American Standard for Cold-Formed Steel Framing—Nonstructural Members, using steel properties alone.
 - Above listed Non-Composite Limiting Heights are applicable when the unbraced length is less than or equal to Lu.
 - Heights are limited by moment, deflection, shear, and web crippling (assuming 1" end reaction bearing).
- 1** Web-height to thickness ratio exceeds 200. Web stiffeners are required at bearing points.
- *Higher heights can be achieved by using end-bearing stiffeners. See full ProSTUD non-composite charts at clarkdietrich.com.

ProSTUD® NON-COMPOSITE LIMITING HEIGHTS

ClarkDietrich ProSTUD Non-Composite Limiting Heights—BRACED AT 48" o.c.

Depth (in)	Stud member	Design thickness (in)	Yield strength (ksi)	Spacing o.c. (in)	Lateral Load (psf)											
					5psf			7.5psf			10psf					
					L/120	L/240	L/360	L/120	L/240	L/360	L/120	L/240	L/360			
1-5/8	ProSTUD 25 162PDS125-15	0.0158	50	12	8' 1"	7' 4"	6' 4"	6' 7"	6' 4"	5' 7"	5' 9"	5' 9"	4' 11"	4' 11"	4' 7"	
		0.0158	50	16	7' 0"	6' 8"	5' 9"	5' 9"	5' 9"	5' 1"	4' 11"	4' 11"	4' 7"	4' 7"	4' 7"	
		0.0158	50	24	5' 9"	5' 9"	5' 1"	4' 8"	4' 8"	4' 5"	4' 0"	4' 0"	4' 0"	4' 0"	4' 0"	
	ProSTUD 20 162PDS125-19	0.0200	65	12	9' 11"	7' 10"	6' 10"	8' 6"	6' 10"	6' 0"	7' 4"	6' 3"	5' 5"	6' 4"	5' 8"	4' 11"
		0.0200	65	16	9' 0"	7' 2"	6' 3"	7' 4"	6' 3"	5' 5"	6' 4"	5' 2"	4' 11"	4' 11"	4' 4"	
		0.0200	65	24	7' 4"	6' 3"	5' 5"	6' 0"	5' 5"	4' 9"	5' 2"	4' 11"	4' 11"	4' 4"	4' 4"	
	ProSTUD 30MIL 162PDS125-30	0.0312	33	12	11' 10"	9' 5"	8' 3"	10' 3"	8' 3"	7' 2"	8' 11"	7' 6"	6' 9"	6' 9"	6' 6"	
		0.0312	33	16	10' 9"	8' 7"	7' 6"	8' 11"	7' 6"	6' 6"	7' 8"	6' 9"	6' 9"	5' 11"	5' 11"	
		0.0312	33	24	8' 11"	7' 6"	6' 6"	7' 3"	6' 6"	5' 8"	6' 3"	5' 11"	5' 11"	5' 2"	5' 2"	
	ProSTUD 33MIL 162PDS125-33	0.0346	33	12	12' 3"	9' 9"	8' 6"	10' 8"	8' 6"	7' 5"	9' 5"	7' 9"	7' 9"	6' 9"	6' 9"	
		0.0346	33	16	11' 2"	8' 10"	7' 9"	9' 5"	7' 9"	6' 9"	8' 2"	7' 0"	7' 0"	6' 1"	6' 1"	
		0.0346	33	24	9' 5"	7' 9"	6' 9"	7' 8"	6' 9"	5' 11"	6' 8"	6' 1"	6' 1"	5' 4"	5' 4"	
2-1/2	ProSTUD 25 250PDS125-15	0.0158	50	12	10' 5"	10' 2"	8' 11"	8' 6"	8' 6"	7' 9"	7' 4"	7' 4"	6' 5"	6' 5"	6' 5"	
		0.0158	50	16	9' 0"	9' 0"	8' 1"	7' 4"	7' 4"	7' 1"	6' 5"	6' 5"	6' 5"	6' 5"	6' 5"	
		0.0158	50	24	7' 4"	7' 4"	7' 1"	6' 0"	6' 0"	6' 0"	5' 3"	5' 3"	5' 3"	5' 3"	5' 3"	
	ProSTUD 20 250PDS125-19	0.0200	65	12	13' 10"	11' 1"	9' 8"	11' 4"	9' 8"	8' 6"	9' 9"	8' 10"	8' 10"	7' 8"	7' 8"	
		0.0200	65	16	12' 0"	10' 1"	8' 10"	9' 9"	8' 10"	7' 8"	8' 6"	8' 0"	7' 0"	7' 0"	7' 0"	
		0.0200	65	24	9' 9"	8' 10"	7' 8"	8' 0"	7' 8"	6' 9"	6' 11"	6' 11"	6' 11"	6' 1"	6' 1"	
	ProSTUD 30MIL 250PDS125-30	0.0312	33	12	16' 5"	13' 0"	11' 4"	13' 8"	11' 4"	9' 11"	11' 10"	10' 4"	9' 0"	9' 0"	9' 0"	
		0.0312	33	16	14' 6"	11' 10"	10' 4"	11' 10"	10' 4"	9' 0"	10' 3"	9' 5"	8' 2"	8' 2"	8' 2"	
		0.0312	33	24	11' 10"	10' 4"	9' 0"	9' 8"	9' 0"	7' 11"	8' 4"	8' 2"	7' 2"	7' 2"	7' 2"	
	ProSTUD 33MIL 250PDS125-33	0.0346	33	12	16' 11"	13' 5"	11' 9"	14' 4"	11' 9"	10' 3"	12' 5"	10' 8"	9' 4"	9' 4"	9' 4"	
		0.0346	33	16	15' 3"	12' 3"	10' 8"	12' 5"	10' 8"	9' 4"	10' 9"	9' 8"	8' 6"	8' 6"	8' 6"	
		0.0346	33	24	12' 5"	10' 8"	9' 4"	10' 2"	9' 4"	8' 2"	8' 10"	8' 6"	7' 5"	7' 5"		
3-5/8	ProSTUD 25 362PDS125-15 ¹	0.0158	50	12	12' 5"	12' 5"	11' 10"	10' 1"	10' 1"	10' 1"	8' 9"	8' 9"	8' 9"	8' 9"		
		0.0158	50	16	10' 9"	10' 9"	10' 9"	8' 9"	8' 9"	8' 9"	7' 7"	7' 7"	7' 7"	7' 7"		
		0.0158	50	24	8' 9"	8' 9"	8' 9"	7' 1"	7' 1"	7' 1"	5' 4"	5' 4"	5' 4"	5' 4"		
	ProSTUD 20 362PDS125-19	0.0200	65	12	16' 9"	14' 11"	13' 0"	13' 8"	13' 0"	11' 5"	11' 10"	11' 10"	10' 4"	10' 4"		
		0.0200	65	16	14' 6"	13' 7"	11' 10"	11' 10"	11' 10"	10' 4"	10' 3"	10' 3"	9' 5"	9' 5"		
		0.0200	65	24	11' 10"	11' 10"	10' 4"	9' 8"	9' 8"	9' 0"	8' 5"	8' 5"	8' 3"	8' 3"		
	ProSTUD 30MIL 362PDS125-30	0.0312	33	12	20' 0"	17' 4"	15' 2"	16' 4"	15' 2"	13' 3"	14' 1"	13' 9"	12' 0"	12' 0"		
		0.0312	33	16	17' 3"	15' 9"	13' 9"	14' 1"	13' 9"	12' 0"	12' 3"	12' 3"	10' 11"	10' 11"		
		0.0312	33	24	14' 1"	13' 9"	12' 0"	11' 6"	11' 6"	10' 6"	10' 0"	10' 0"	9' 6"	9' 6"		
	ProSTUD 33MIL 362PDS125-33	0.0346	33	12	21' 3"	17' 11"	15' 8"	17' 4"	15' 8"	13' 8"	15' 0"	14' 3"	12' 5"	12' 5"		
		0.0346	33	16	18' 5"	16' 3"	14' 3"	15' 0"	14' 3"	12' 5"	13' 0"	12' 11"	11' 3"	11' 3"		
		0.0346	33	24	15' 0"	14' 3"	12' 5"	12' 3"	12' 3"	10' 10"	10' 8"	10' 8"	9' 10"	9' 10"		
4	ProSTUD 25 400PDS125-15 ¹	0.0158	50	12	13' 0"	13' 0"	12' 8"	10' 8"	10' 8"	10' 8"	9' 2"	9' 2"	9' 2"	9' 2"		
		0.0158	50	16	11' 3"	11' 3"	11' 3"	9' 2"	9' 2"	9' 2"	7' 0"	7' 0"	7' 0"	7' 0"		
		0.0158	50	24	9' 2"	9' 2"	9' 2"	6' 3"	6' 3"	6' 3"	4' 8"	4' 8"	4' 8"	4' 8"		
	ProSTUD 20 400PDS125-19	0.0200	65	12	17' 11"	16' 1"	14' 0"	14' 7"	14' 0"	12' 3"	12' 8"	12' 8"	11' 2"	11' 2"		
		0.0200	65	16	15' 6"	14' 7"	12' 9"	12' 8"	12' 8"	11' 2"	11' 0"	11' 0"	10' 1"	10' 1"		
		0.0200	65	24	12' 8"	12' 8"	11' 2"	10' 4"	10' 4"	9' 9"	8' 11"	8' 11"	8' 10"	8' 10"		
	ProSTUD 30MIL 400PDS125-30	0.0312	33	12	21' 1"	18' 8"	16' 4"	17' 2"	16' 4"	14' 3"	14' 11"	14' 10"	13' 0"	13' 0"		
		0.0312	33	16	18' 3"	17' 0"	14' 10"	14' 11"	14' 10"	13' 0"	12' 11"	12' 11"	11' 9"	11' 9"		
		0.0312	33	24	14' 11"	14' 10"	13' 0"	12' 2"	12' 2"	11' 4"	10' 6"	10' 6"	10' 3"	10' 3"		
	ProSTUD 33MIL 400PDS125-33	0.0346	33	12	22' 5"	19' 4"	16' 11"	18' 4"	16' 11"	14' 9"	15' 10"	15' 4"	13' 5"	13' 5"		
		0.0346	33	16	19' 5"	17' 7"	15' 4"	15' 10"	15' 4"	13' 5"	13' 9"	13' 9"	12' 2"	12' 2"		
		0.0346	33	24	15' 10"	15' 4"	13' 5"	13' 0"	13' 0"	11' 9"	11' 3"	11' 3"	10' 8"	10' 8"		
6	ProSTUD 30MIL 600PDS125-30	0.0312	33	12	26' 9"	25' 7"	22' 4"	21' 10"	21' 10"	19' 7"	18' 11"	18' 11"	17' 9"	17' 9"		
		0.0312	33	16	23' 2"	23' 2"	20' 4"	18' 11"	18' 11"	17' 9"	16' 5"	16' 5"	16' 2"	16' 2"		
		0.0312	33	24	18' 11"	18' 11"	17' 9"	15' 5"	15' 5"	15' 5"	13' 5"	13' 5"	13' 5"	13' 5"		
	ProSTUD 33MIL 600PDS125-33	0.0346	33	12	28' 4"	26' 7"	23' 2"	23' 2"	23' 2"	20' 3"	20' 1"	20' 1"	18' 5"	18' 5"		
		0.0346	33	16	24' 7"	24' 1"	21' 1"	20' 1"	20' 1"	18' 5"	17' 5"	17' 5"	16' 9"	16' 9"		
		0.0346	33	24	20' 1"	20' 1"	18' 5"	16' 5"	16' 5"	16' 1"	14' 2"	14' 2"	14' 2"	14' 2"		

Notes:

- Heights are based on AISI S100-07, North American Specification and AISI S220-11, North American Standard for Cold-Formed Steel Framing—Nonstructural Members, using steel properties alone.
- Allowable moment capacities are based on discrete stud bracing at 4 ft. o.c.
- Heights are limited by moment, deflection, shear, and web crippling (assuming 1" end reaction bearing).

¹ Web-height to thickness ratio exceeds 200. Web stiffeners are required at bearing points.

*Higher heights can be achieved by using end-bearing stiffeners. See full ProSTUD non-composite charts at clarkdietrich.com.

ProSTUD® 3-5/8" SOUND ASSEMBLIES

Partition type	Assembly description	STC Rating / Test Report			
		ProSTUD 25 (15mil)	ProSTUD 20 (19mil)	ProSTUD 30MIL	ProSTUD 33MIL
	3-5/8" ProSTUD @ 24" o.c. 1 layer 5/8" Type X GWB on each side	43 TL09-539	38 TL13-190	36 TL13-201	36 TL13-197
	3-5/8" ProSTUD @ 24" o.c. 3-1/2" R-13* unfaced insulation 1 layer 5/8" Type X GWB on each side	48 TL09-540	41 TL13-189	37 TL13-202	37 TL13-196
	3-5/8" ProSTUD @ 24" o.c. 3-1/2" R-13* unfaced insulation 1 layer 5/8" Type X GWB on one side 2 layers 5/8" Type X GWB on the other side	49 TL13-167	44 TL13-188	40 TL13-203	42 TL13-195
	3-5/8" ProSTUD @ 24" o.c. 3-1/2" R-13* unfaced insulation 2 layers 5/8" Type X GWB on each side	54 TL09-538	45 TL13-187	42 TL13-204	45 TL13-194
	3-5/8" ProSTUD @ 24" o.c. 3-1/2" R-13* unfaced insulation RC-Deluxe w/ 1 layer 5/8" Type X GWB on one side 1 layer 5/8" Type X GWB on the other side	53 TL13-183	48 TL13-191	48 TL13-205	48 TL13-198
	3-5/8" ProSTUD @ 24" o.c. 3-1/2" R-13* unfaced insulation RC-Deluxe w/ 2 layers 5/8" Type X GWB on one side 1 layer 5/8" Type X GWB on the other side	59 TL09-543	54 TL13-192	52 TL13-206	54 TL13-199
	3-5/8" ProSTUD @ 24" o.c. 3-1/2" R-13* unfaced insulation RC-Deluxe w/ 2 layers 5/8" Type X GWB on one side 2 layers 5/8" Type X GWB on the other side	62 TL13-181	59 TL13-193	56 TL13-207	58 TL13-200

Notes:

- Sound Assemblies are certified by Western Electro-Acoustic Laboratories.
- NVLAP Accredited for ASTM E90 & E413, ISO Certified.
- See STC test reports at www.clarkdietrich.com/ProSTUD for detailed requirements of construction of wall assembly.

* Values are the same for R-11 insulation.

Contact ClarkDietrich Technical Services at 888-437-3244 for questions about ProSTUD sound assemblies.

ProSTUD 1-5/8" STUD CHASE SOUND ASSEMBLIES**Two parallel rows**

Gypsum type	Side A	Side B	Insulation type	Stud spacing	STC Rating	Test report	Partition type
					ProSTUD 25 (15mil)		
5/8" Type X	1 layer	1 layer	R-13* unfaced	24"	55	TL09-590	1 Similar
5/8" Type X	1 layer	2 layers	R-13* unfaced	24"	59	TL09-591	1 Similar
5/8" Type X	2 layers	2 layers	R-13* unfaced	24"	61	TL09-592	1

ProSTUD 2-1/2" STUD CHASE SOUND ASSEMBLIES**Staggered in opposite walls**

Gypsum type	Side A	Side B	Insulation type	Stud spacing	STC Rating	Test report	Partition type
					ProSTUD 25 (15mil)		
5/8" Type X	1 layer	1 layer	R-13* unfaced*	24"	58	TL09-593	2 Similar
5/8" Type X	1 layer	2 layers	R-13* unfaced*	24"	63	TL09-594	2 Similar
5/8" Type X	2 layers	2 layers	R-13* unfaced*	24"	65	TL09-595	2

ProSTUD 3-5/8" STUD CHASE SOUND ASSEMBLIES**Staggered studs in 6" track**

Gypsum type	Side A	Side B	Insulation type	Stud spacing	STC Rating	Test report	Partition type
					ProSTUD 25 (15mil)		
5/8" Type X	1 layer	1 layer	R-13* unfaced	16"	49	TL09-587	3
5/8" Type X	1 layer	2 layers	R-13* unfaced	16"	52	TL09-588	3 Similar
5/8" Type X	2 layers	2 layers	R-13* unfaced	16"	56	TL09-589	3 Similar

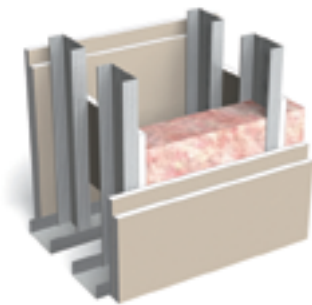
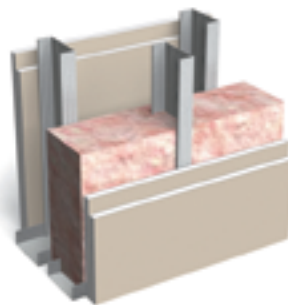
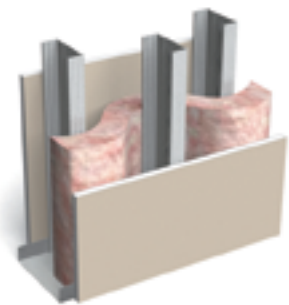
Partition
Type 1Partition
Type 2Partition
Type 3**Notes:**

- Sound Assemblies are certified by Western Electro-Acoustic Laboratories.
- NVLAP Accredited for ASTM E90 & E413, ISO Certified.
- See STC test reports at www.clarkdietrich.com/ProSTUD for detailed requirements of construction of wall assembly.

* Values are the same for R-11 insulation.

Contact ClarkDietrich Technical Services at 888-437-3244 for questions about ProSTUD sound assemblies.

ProSTUD® SINGLE STUD WALL—FIRE ASSEMBLIES^A

UL design no.	Hourly rating	ProSTUD minimum thickness	ProSTUD minimum depth
U403	2	ProSTUD 20 (19mil)	3-5/8"
U407	1/2 or 1	ProSTUD 25 (15mil)	3-5/8"
U408	2	ProSTUD 20 (19mil)	3-5/8"
U411	2	ProSTUD 25 (15mil)	2-1/2"
U412	2	ProSTUD 25 (15mil)	1-5/8"
U419	1, 2, 3 or 4	ProSTUD 25 (15mil)	(See Table 1 below)
U421	2	ProSTUD 25 (15mil)	3-5/8"
U431	4	ProSTUD 20 (19mil)	3-5/8"
U435	3 or 4	ProSTUD 25 (15mil)	1-5/8"
U442*	1	ProSTUD 33MIL	2-1/2"
U450	1 or 3	ProSTUD 20 (19mil)	3-5/8"
U451	1	ProSTUD 20 (19mil)	2-1/2"
U454	2	ProSTUD 20 (19mil)	2-1/2"
U463	3 or 4	ProSTUD 20 (19mil)	1-5/8"
U465	1	ProSTUD 20 (19mil)	3-5/8"
U471	1-1/2	ProSTUD 20 (19mil)	3-5/8"
U475	1, 2 or 3	ProSTUD 20 (19mil)	3-5/8"
U478	3	ProSTUD 20 (19mil)	1-5/8"
U484*	2	ProSTUD 33MIL	2-1/2"
U488*	1	ProSTUD 33MIL	2-1/2"
U490	4	ProSTUD 20 (19mil)	2-1/2"
U491	2	ProSTUD 20 (19mil)	3-5/8"
U494	1	ProSTUD 20 (19mil)	2-1/2"
U495	1 or 2	ProSTUD 20 (19mil)	3-5/8"
U496	1	ProSTUD 20 (19mil)	1-5/8"

UL design no.	Hourly rating	ProSTUD minimum thickness	ProSTUD minimum depth
V410	2	ProSTUD 20 (19mil)	1-5/8"
V412	2	ProSTUD 20 (19mil)	3-5/8"
V416	1	ProSTUD 20 (19mil)	3-5/8"
V417	1	ProSTUD 20 (19mil)	3-5/8"
V418	2	ProSTUD 20 (19mil)	1-5/8"
V419	2	ProSTUD 20 (19mil)	2-1/2"
V425	1	ProSTUD 20 (19mil)	2-1/2"
V435	1	ProSTUD 20 (19mil)	3-5/8"
V438	1, 2, 3 or 4	ProSTUD 25 (15mil)	(See Table 1 below)
V443	4	ProSTUD 20 (19mil)	3-5/8"
V444	1	ProSTUD 20 (19mil)	3-5/8"
V448	1	ProSTUD 20 (19mil)	3-5/8"
V449	2	ProSTUD 20 (19mil)	3-5/8"
V450	1	ProSTUD 25 (15mil)	3-5/8"
V450	2	ProSTUD 25 (15mil)	2-1/2"
V452	1 or 2	ProSTUD 20 (19mil)	3-5/8"
V453*	1-1/2	ProSTUD 33MIL	6"
V461*	1	ProSTUD 33MIL	3-5/8"
V476	1 or 3	ProSTUD 20 (19mil)	3-5/8"
V477	1, 2, 3 or 4	ProSTUD 25 (15mil)	(See Table 1 below)
V487	2	ProSTUD 20 (19mil)	1-5/8"
V489	1, 2, 3 or 4	ProSTUD 25 (15mil)	(See Table 1 below)
V498	1, 2, 3 or 4	ProSTUD 25 (15mil)	(See Table 1 below)
W411	1/2 or 1	ProSTUD 25 (15mil)	3-5/8"
W415	1 or 2	ProSTUD 20 (19mil)	2-1/2"
W424	1	ProSTUD 25 (15mil)	3-5/8"

ProSTUD CHASE OR DOUBLE STUD—FIRE ASSEMBLIES^A

UL design no.	Hourly rating	ProSTUD minimum thickness	ProSTUD minimum depth
U420	2	ProSTUD 25 (15mil)	1-5/8"
U436	1, 2, or 3	ProSTUD 20 (19mil)	1-5/8"
U444	2	ProSTUD 25 (15mil)	1-5/8"
U445*	1	ProSTUD 33MIL	1-5/8"
U466	1	ProSTUD 20 (19mil)	2-1/2"
U493	2	ProSTUD 25 (15mil)	2-1/2"
V437	1	ProSTUD 20 (19mil)	1-5/8"

UL design no.	Hourly rating	ProSTUD minimum thickness	ProSTUD minimum depth
V442	2	ProSTUD 25 (15mil)	1-5/8"
V469*	1	ProSTUD 33MIL	2-1/2"
V469	2	ProSTUD 20 (19mil)	2-1/2"
V488	1 or 2	ProSTUD 20 (19mil)	2-1/2"
V490*	1 or 2	ProSTUD 33MIL	2-1/2"
V496	1 or 2	ProSTUD 20 (19mil)	2-1/2"
V425	1 or 2	ProSTUD 20 (19mil)	2-1/2"

ProSTUD TABLE 1: MINIMUM DEPTH OF ProSTUD REQUIRED^A

Hourly rating	Min. stud depth (in)	No. of layers and thickness of gypsum board	UL U419	UL V438	UL V477	UL V489	UL V498
1	2-1/2"	1 layer, 1/2"	—	—	—	✓	—
1	3-5/8"	1 layer, 5/8"	✓	✓	✓	✓	✓
2	1-5/8"	2 layer, 1/2"	✓	✓	✓	✓	✓
2	1-5/8"	2 layer, 5/8"	✓	—	✓	✓	✓
2	2-1/2"	2 layer, 5/8"	—	✓	—	—	—
3	1-5/8"	3 layer, 1/2"	✓	✓	✓	✓	✓
3	1-5/8"	3 layer, 5/8"	✓	✓	✓	✓	✓
4	1-5/8"	4 layer, 1/2"	✓	✓	✓	✓	✓
4	1-5/8"	4 layer, 5/8"	✓	✓	✓	✓	✓

Notes:

^A See UL listing for detailed requirements of construction of tested assembly.

* ProSTUD meets or exceeds the description of generic stud/track members listed in the UL assembly.



DEEP LEG DEFLECTION TRACK SYSTEMS

Head-of-wall vertical deep leg deflection track systems are required to allow the top of the wall stud to float within the top track legs. This condition allows for vertical live load movement of the primary structure without transferring axial loads to the interior drywall studs. A gap (determined by the Engineer of Record) is required between the top of the wall stud and the deflection track.

ProSTUD® Drywall Framing studs can be used with the three Deep Leg Track Systems listed below:

ProTRAK® Deep Leg Track

ProTRAK deep leg track is available with leg lengths of 2", 2-1/2" and 3" long.

The wall studs are not fastened to the deflection track, and a row of lateral bracing is required within 12" of the deep leg track to prevent rotation and lateral movement of the studs. The deflection track system must be designed for the end reaction of the wall studs (point loads) and for the specific gap required for vertical deflection.

ProTRAK® Allowable Lateral Loads and Wall Heights

Deflection track system	2" Leg Track with 1/2" Gap		2-1/2" Leg Track with 3/4" Gap		3" Leg Track with 1" Gap	
	Allowable load (lbs)	Limiting wall height	Allowable load (lbs)	Limiting wall height	Allowable load (lbs)	Limiting wall height
ProTRAK 25	36	10' 8"	24	7' 2"	18	5' 4"
ProTRAK 20	57	17' 2"	38	11' 5"	29	8' 7"
ProTRAK 30MIL	92	27' 6"	61	18' 4"	46	13' 9"
ProTRAK 33MIL	113	33' 10"	75	22' 7"	56	16' 11"

Notes:

- Limiting wall heights are based on studs spaced at 16" o.c. and an interior lateral load of 5psf.
- Stud members must be analyzed independently of the track system. Use www.iProSTUD.com to check limiting wall heights for ProSTUD members.
- Stud failure modes relating to the deflection track connection (shear, web crippling, etc.) must be checked separately.

Structural Deep Leg Track (18ga & 16ga)

Structural Deep Leg Track systems are installed the same as the ProTRAK deep leg track system but are designed to handle tall wall systems.

For structural deep leg track allowable loads, contact Technical Services at 888-437-3244 or visit clarkdietrich.com.

Slotted Deflection Track from ClarkDietrich

The slotted deflection track is attached to the wall studs through vertical slots using wafer head screws, creating a positive connection that allows for vertical movement and also eliminates the requirement for lateral bracing near the top of the wall stud.

MaxTrak™ Allowable Lateral Loads and Wall Heights

Deflection track system	ProSTUD 25 (15mil, 50ksi)		ProSTUD 20 (19mil, 65ksi)		ProSTUD 30mil (33ksi)		ProSTUD 25 33mil (33ksi)	
	Allowable load (lbs)	Limiting wall height	Allowable load (lbs)	Limiting wall height	Allowable load (lbs)	Limiting wall height	Allowable load (lbs)	Limiting wall height
MaxTrak 30MIL	45	13' 6"	85	25' 6"	148	44' 4"	148	44' 4"
MaxTrak 33MIL	52	15' 7"	99	29' 7"	156	46' 10"	156	46' 10"

Notes:

- Allowable loads are based on screws through the slots located 1-1/4" from the track web.
- #8 minimum wafer head screws shall be used for stud-track connection.
- The above table is applicable to ProSTUD members only. ProSTUD allowable heights must be checked also.
- Allowable heights are based on 5psf and wall stud spacing at 16" o.c. with a max. gap of 7/8"

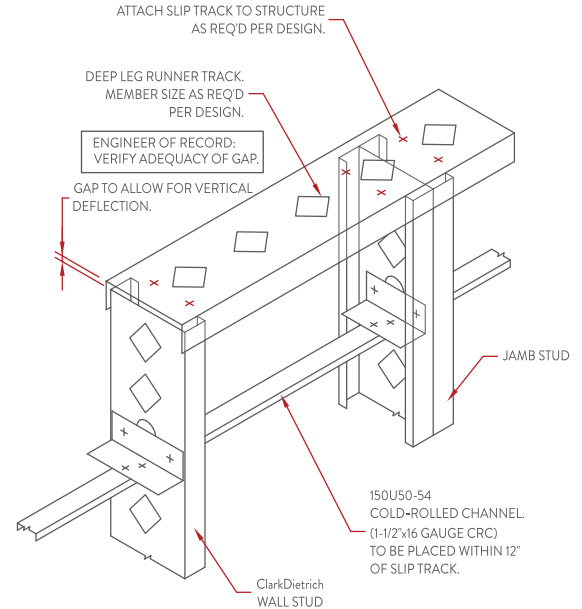

1 DEEP LEG DEFLECTION TRACK DETAIL WITH LATERAL BRACING WITHIN 12" OF SLIP TRACK

Details shown are for example only. The engineer of record of the project is responsible for the design of the connection to the structure. Additional connection details can be found at clarkdietrich.com.

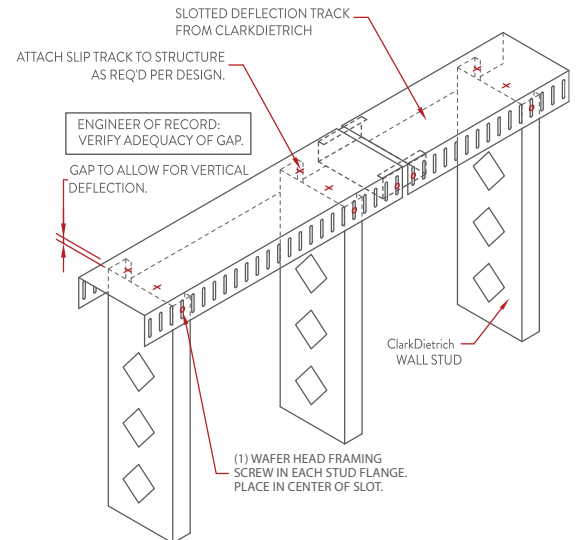

2 SLOTTED DEFLECTION TRACK DETAIL WITH TRACK SPLICE

ClarkDietrich offers both the MaxTrak® Slotted Deflection Track and BlazeFrame® Integrated Fire Stop System. Find more information on these systems at clarkdietrich.com.

ProSTUD® ALLOWABLE CEILING SPANS		Deflection Limit L/240											
Section	F _y (ksi)	4psf Lateral Support of Compression Flange						6psf Lateral Support of Compression Flange					
		Unsupported joist spacing (in) o.c.			Mid-span joist spacing (in) o.c.			Unsupported joist spacing (in) o.c.			Mid-span joist spacing (in) o.c.		
		12	16	24	12	16	24	12	16	24	12	16	24
162PDS125-15	50	7' 3"	6' 8"	5' 11"	7' 10"	7' 2"	6' 3"	6' 5"	5' 11"	5' 3"	6' 10"	6' 3"	5' 5"
250PDS125-15	50	8' 4"	7' 8"	6' 11"	10' 11"	9' 11"	8' 8"	7' 5"	6' 11"	6' 2"	9' 7"	8' 8"	7' 7"
350PDS125-15	50	9' 1"	8' 5"	7' 6"	12' 7"	11' 6"	10' 2"	8' 2"	7' 6"	6' 8"	11' 1"	10' 2"	8' 10" e
362PDS125-15	50	9' 2"	8' 6"	7' 7"	12' 9"	11' 8"	10' 3"	8' 3"	7' 7"	6' 9"	11' 3"	10' 3"	8' 11" e
400PDS125-15	50	9' 5"	8' 9"	7' 10"	13' 1"	12' 0"	10' 7" e	8' 6"	7' 10"	6' 11" e	11' 7" e	10' 7" e	9' 3" e
162PDS125-19	65	7' 11"	7' 4"	6' 6"	8' 5"	7' 8"	6' 9"	7' 2"	6' 6"	5' 9"	7' 5"	6' 9"	5' 11"
250PDS125-19	65	9' 1"	8' 5"	7' 7"	11' 11"	10' 10"	9' 6"	8' 2"	7' 7"	6' 10"	10' 5"	9' 6"	8' 3"
350PDS125-19	65	10' 0"	9' 4"	8' 4"	14' 4"	13' 2"	11' 9"	9' 0"	8' 4"	7' 6"	12' 9"	11' 9"	10' 5"
362PDS125-19	65	10' 2"	9' 5"	8' 5"	14' 6"	13' 4"	11' 10"	9' 1"	8' 5"	7' 7"	12' 11"	11' 10"	10' 6"
400PDS125-19	65	10' 5"	9' 8"	8' 8"	14' 11"	13' 9"	12' 3"	9' 5"	8' 8"	7' 10"	13' 4"	12' 3"	10' 11"
162PDS125-30	33	9' 4"	8' 7"	7' 8"	9' 10"	9' 0"	7' 10"	8' 3"	7' 8"	6' 10"	8' 7"	7' 10"	6' 10"
250PDS125-30	33	10' 4"	9' 7"	8' 6"	13' 8"	12' 5"	10' 10"	9' 3"	8' 6"	7' 8"	11' 11"	10' 10"	9' 6"
350PDS125-30	33	11' 2"	10' 4"	9' 3"	16' 0"	14' 10"	13' 4"	10' 0"	9' 3"	8' 4"	14' 5"	13' 4"	11' 11"
362PDS125-30	33	11' 3"	10' 5"	9' 4"	16' 2"	15' 0"	13' 6"	10' 1"	9' 4"	8' 5"	14' 7"	13' 6"	12' 0"
400PDS125-30	33	11' 7"	10' 9"	9' 8"	16' 8"	15' 6"	13' 11"	10' 5"	9' 8"	8' 8"	15' 0"	13' 11"	12' 5"
550PDS125-30	33	12' 10"	11' 10"	10' 8"	18' 5"	17' 1"	15' 4"	11' 6"	10' 8"	9' 7"	16' 7"	15' 4"	13' 9"
600PDS125-30	33	13' 1"	12' 2"	10' 11"	18' 11"	17' 6"	15' 8"	11' 9"	10' 11"	9' 10"	17' 0"	15' 8"	14' 1"
162PDS125-33	33	9' 9"	9' 0"	8' 0"	10' 4"	9' 4"	8' 2"	8' 8"	8' 0"	7' 1"	9' 0"	8' 2"	7' 2"
250PDS125-33	33	10' 9"	9' 11"	8' 10"	14' 3"	12' 11"	11' 3"	9' 7"	8' 10"	7' 11"	12' 5"	11' 3"	9' 10"
350PDS125-33	33	11' 7"	10' 8"	9' 7"	16' 6"	15' 3"	13' 9"	10' 4"	9' 7"	8' 7"	14' 10"	13' 9"	12' 4"
362PDS125-33	33	11' 8"	10' 9"	9' 8"	16' 8"	15' 5"	13' 11"	10' 5"	9' 8"	8' 8"	15' 0"	13' 11"	12' 6"
400PDS125-33	33	12' 0"	11' 1"	9' 11"	17' 2"	15' 11"	14' 4"	10' 9"	9' 11"	8' 11"	15' 5"	14' 4"	12' 10"
550PDS125-33	33	13' 3"	12' 3"	11' 0"	19' 0"	17' 7"	15' 10"	11' 10"	11' 0"	9' 10"	17' 1"	15' 10"	14' 3"
600PDS125-33	33	13' 6"	12' 6"	11' 3"	19' 6"	18' 1"	16' 3"	12' 2"	11' 3"	10' 1"	17' 6"	16' 3"	14' 7"

ProSTUD ALLOWABLE CEILING SPANS		Deflection Limit L/360											
Section	F _y (ksi)	4psf Lateral Support of Compression Flange						6psf Lateral Support of Compression Flange					
		Unsupported joist spacing (in) o.c.			Mid-span joist spacing (in) o.c.			Unsupported joist spacing (in) o.c.			Mid-span joist spacing (in) o.c.		
		12	16	24	12	16	24	12	16	24	12	16	24
162PDS125-15	50	6' 10"	6' 3"	5' 5"	6' 10"	6' 3"	5' 5"	6' 0"	5' 5"	4' 9"	6' 0"	5' 5"	4' 9"
250PDS125-15	50	8' 4"	7' 8"	6' 11"	9' 7"	8' 8"	7' 7"	7' 5"	6' 11"	6' 2"	8' 4"	7' 7"	6' 8"
350PDS125-15	50	9' 1"	8' 5"	7' 6"	12' 5"	11' 4"	9' 11"	8' 2"	7' 6"	6' 8"	10' 10"	9' 11"	8' 8" e
362PDS125-15	50	9' 2"	8' 6"	7' 7"	12' 9"	11' 7"	10' 1"	8' 3"	7' 7"	6' 9"	11' 2"	10' 1"	8' 10" e
400PDS125-15	50	9' 5"	8' 9"	7' 10"	13' 1"	12' 0"	10' 7" e	8' 6"	7' 10"	6' 11" e	11' 7" e	10' 7" e	9' 3" e
162PDS125-19	65	7' 5"	6' 9"	5' 11"	7' 5"	6' 9"	5' 11"	6' 5"	5' 11"	5' 2"	6' 6"	5' 11"	5' 2"
250PDS125-19	65	9' 1"	8' 5"	7' 7"	10' 5"	9' 6"	8' 3"	8' 2"	7' 7"	6' 10"	9' 1"	8' 3"	7' 3"
350PDS125-19	65	10' 0"	9' 4"	8' 4"	13' 8"	12' 5"	10' 10"	9' 0"	8' 4"	7' 6"	11' 11"	10' 10"	9' 6"
362PDS125-19	65	10' 2"	9' 5"	8' 5"	14' 1"	12' 9"	11' 2"	9' 1"	8' 5"	7' 7"	12' 3"	11' 2"	9' 9"
400PDS125-19	65	10' 5"	9' 8"	8' 8"	14' 11"	13' 9"	12' 0"	9' 5"	8' 8"	7' 10"	13' 2"	12' 0"	10' 6"
162PDS125-30	33	8' 7"	7' 10"	6' 10"	8' 7"	7' 10"	6' 10"	7' 6"	6' 10"	6' 0"	7' 6"	6' 10"	6' 0"
250PDS125-30	33	10' 4"	9' 7"	8' 6"	11' 11"	10' 10"	9' 6"	9' 3"	8' 6"	7' 8"	10' 5"	9' 6"	8' 3"
350PDS125-30	33	11' 2"	10' 4"	9' 3"	15' 6"	14' 1"	12' 4"	10' 0"	9' 3"	8' 4"	13' 6"	12' 4"	10' 9"
362PDS125-30	33	11' 3"	10' 5"	9' 4"	15' 11"	14' 6"	12' 8"	10' 1"	9' 4"	8' 5"	13' 11"	12' 8"	11' 1"
400PDS125-30	33	11' 7"	10' 9"	9' 8"	16' 8"	15' 6"	13' 9"	10' 5"	9' 8"	8' 8"	15' 0"	13' 9"	12' 0"
550PDS125-30	33	12' 10"	11' 10"	10' 8"	18' 5"	17' 1"	15' 4"	11' 6"	10' 8"	9' 7"	16' 7"	15' 4"	13' 9"
600PDS125-30	33	13' 1"	12' 2"	10' 11"	18' 11"	17' 6"	15' 8"	11' 9"	10' 11"	9' 10"	17' 0"	15' 8"	14' 1"
162PDS125-33	33	9' 0"	8' 2"	7' 2"	9' 0"	8' 2"	7' 2"	7' 10"	7' 2"	6' 3"	7' 10"	7' 2"	6' 3"
250PDS125-33	33	10' 9"	9' 11"	8' 10"	12' 5"	11' 3"	9' 10"	9' 7"	8' 10"	7' 11"	10' 10"	9' 10"	8' 7"
350PDS125-33	33	11' 7"	10' 8"	9' 7"	16' 1"	14' 7"	12' 9"	10' 4"	9' 7"	8' 7"	14' 1"	12' 9"	11' 2"
362PDS125-33	33	11' 8"	10' 9"	9' 8"	16' 6"	15' 0"	13' 2"	10' 5"	9' 8"	8' 8"	14' 5"	13' 2"	11' 6"
400PDS125-33	33	12' 0"	11' 1"	9' 11"	17' 2"	15' 11"	14' 3"	10' 9"	9' 11"	8' 11"	15' 5"	14' 3"	12' 5"
550PDS125-33	33	13' 3"	12' 3"	11' 0"	19' 0"	17' 7"	15' 10"	11' 10"	11' 0"	9' 10"	17' 1"	15' 10"	14' 3"
600PDS125-33	33	13' 6"	12' 6"	11' 3"	19' 6"	18' 1"	16' 3"	12' 2"	11' 3"	10' 1"	17' 6"	16' 3"	14' 7"

- Notes:**
- For unbraced sections, allowable moment is based on 2007 AISI Specification Section C3.1.2 with weak axis and torsional unbraced length assumed to be the listed span (completely unbraced). For mid-span braced sections, allowable moment based on 2007 AISI Specification Section C3.1.2 with weak axis and torsional unbraced length assumed to be one-half of the listed span (bracing at mid-span).
 - Web crippling calculation based on bearing length = 1 inch.
 - Web crippling and shear capacity have not been reduced for punchouts. If web punchouts occur near support members must be checked for reduced shear and web crippling in accordance with the 2007 AISI Specification.
 - Values are for simple span conditions.
 - Web stiffeners required at support.

ClarkDietrich LEED® INFORMATION AND REQUIREMENTS



ClarkDietrich
LEED Request Form
online at clarkdietrich.com

LEED Credit MR 2 (Construction Waste Management)

ClarkDietrich products are manufactured from cold-formed steel. Steel is 100% recyclable. This attribute can help when diverting construction debris from the waste stream. Recycling construction waste contributes to LEED Credits MR 2.1 and 2.2. The specific contribution will vary by project and must be determined by the contractor. (Up to 2 pts.)

LEED Credit MR 4 (Recycled Content)

ClarkDietrich produces cold-formed steel framing products with a minimum recycled content of 34.9%, of which 24.3% is post-consumer and 9.4% is pre-consumer. These minimum values are based on resources from Steel Recycling Institute. Recycled content of materials contributes to LEED Credits MR 4.1 and 4.2, and possibly an Innovation in Design Credit if the project's overall recycled content exceeds 30%. If a higher content is desired, ClarkDietrich can provide this information if mill certifications are requested at time of order. (Up to 3 pts.)

LEED Credit MR 5 (Regional Materials)

LEED Credit MR 5 requires the jobsite to be within a 500 mile radius of the manufacturing plant and from the point of extraction of raw materials. With nationwide manufacturing locations, ClarkDietrich plants, as well as our steel sources, often fall within the required 500 mile radius. Each product must be tracked from the mill to the project location and then these values must be weighted by recycled content percentages. If you wish to report MR 5 Credits, please submit a LEED request through clarkdietrich.com or contact ClarkDietrich Technical Services at 888-437-3244 for procedures. (Up to 2 pts.)

ClarkDietrich Building Systems

ClarkDietrich Building Systems, Inc. is an active member of the U.S. Green Building Council with LEED® Accredited Professionals on staff. ClarkDietrich is committed to supplying quality products and continually looking for new ways to develop greener building products and sustainable business practices. In total, ClarkDietrich products can help your project qualify for up to 7 LEED Credits under LEED for New Construction and Major Renovations (LEED-NC Ver. 2.2 and 3.0).



ClarkDietrich plant locations: Riverside, CA
Sacramento, CA
Bristol, CT
Dade City, FL

McDonough, GA
Kapolei, HI
Rochelle, IL
Baltimore, MD

Warren, OH
Baytown, TX
Dallas, TX

SUPPORT TOOLS



clarkdietrich.com

Visit to explore company information, design tools, technical documents, services and so much more. Featuring a unique product selector, our website is designed to deliver the details you want with a minimum number of clicks.



iProSTUD.com

Going mobile? With your smartphone in hand, you can perform a fast, easy search, view ProSTUD limiting heights and even email submittal documents.



SubmittalPro®

We built this online technical submittal generator tool to make your job easier. Use it to quickly view data on our products and create your final submittal documents. Access SubmittalPro at clarkdietrich.com or on your desktop or smartphone.



Architectural Specification Review

Over time, project specifications can become outdated. For suggestions on how to improve the performance of your specifications, contact us about a complimentary review at 330-372-5564, ext. 244.



Technical Services

Count on ClarkDietrich Technical Services to respond to a variety of needs, from general questions on industry standards to specifics on accurate sizing. Call us at 888-437-3244.

ProSTUD® & ProTRAK® CODE APPROVALS AND PERFORMANCE STANDARDS

ClarkDietrich™ ProSTUD Drywall Framing System meets or exceeds these applicable performance standards.

AISI S100-07 North American Specification for the Design of Cold-Formed Steel Structural Members

AISI S220-11 North American Standard for Cold-Formed Steel Framing—Nonstructural Members

ASTM American Society for Testing and Materials

- A1003** "Material specification for steel sheet mechanical and chemical requirements"
C645 "Standard Specification for Nonstructural Steel Framing Members"
C754 "Standard Specification for Installation of Steel Framing Members to Receive Screw-Attached Gypsum Panel Products"
C1002 "Standard Specification for Steel Self Piercing Tapping Screw for the Application of Gypsum Panel Products or Metal Plaster Bases to Wood Studs or Steel Studs"
E119 "Standard Test Methods for Fire Tests of Building Construction and Materials"
E72 "Standard Test Methods of Conducting Strength Tests of Panels for Building Construction"
E90 "Standard Test Method for Laboratory Measurement of Airborne Sound Transmission Loss of Building Partitions and Elements"

UL® Underwriters Laboratories testing standard

UL 263 "Fire Tests of Building Construction and Materials"

Multiple UL® design listings for ProSTUD

Over 50 UL Designs. See UL file number R26512 for additional information.

UL® and UL® Design are service marks of Underwriters Laboratories, Inc.

Independent product testing and certification

Sound ratings: (WEAL) Western Electro-Acoustic Laboratory
 Fire testing: (UL) Underwriters Laboratories Inc.
Additional code approvals
 SFIA (Steel Framing Industry Association)
 ATICRR-0207



Scan for the most up-to-date ClarkDietrich literature.

ClarkDietrich Building Systems is a proud member of the Steel Framing Industry Association (SFIA). Check the updated list of Certified Production Facilities at Architectural Testing's website at www.archtest.com.

LEED® Credit MR 2

Construction Waste Management (Up to 2 points)

ClarkDietrich products are manufactured from cold-formed steel. Steel is 100% recyclable, which helps divert debris from the waste stream. The contribution to LEED must be calculated by the contractor based on weight or volume.

LEED Credit MR 4 Recycled Content (Up to 3 points)

ClarkDietrich Building Systems produces products with a minimum recycled content of 34.9%, of which 24.3% is post-consumer and 9.4% is pre-consumer. These minimum values are based on resources from Steel Recycling Institute. If a higher content is desired, ClarkDietrich can provide this information if mill certifications are requested at time of order. ClarkDietrich recycles nearly 100% of its post-industrial scrap.

ClarkDietrich Building Systems has prepared this literature with the utmost diligence and care for accuracy and conformance to standards.

ClarkDietrich intends this information to be accurate, informative, and helpful as a selection guide for choosing ClarkDietrich Building System products. However, this information is only to be used for guidance and is not intended to replace the design, drawings, specifications, and decisions of a professional architect or engineer.

ClarkDietrich Building Systems or its affiliates shall not be responsible for incidental or consequential damages, directly or indirectly sustained, nor for loss caused by application of our products for other than their intended uses. Our liability is limited to replacement of defective products. Claims shall be deemed waived unless they are made to us in writing within thirty (30) days of the date a problem was or reasonably should have been discovered.

ClarkDietrich Building Systems reserves the right to modify or change any information contained in this literature without notification.



USGBC and related logo is a trademark owned by the U.S. Green Building Council and is used by permission.

LOCATIONS

ClarkDietrich Building Systems Manufacturing and Sales Locations:

CALIFORNIA Riverside
 P 951.360.3500
 F 951.360.3333

CALIFORNIA Sacramento
 P 951.360.3500
 F 951.360.3333

CONNECTICUT Bristol
 P 866.921.0023
 F 860.584.6899

FLORIDA Dade City
 P 352.518.4400
 F 352.518.4450

GEORGIA McDonough
 P 678.304.5500
 F 678.304.5555

HAWAII Kapolei
 P 951.360.3500
 F 951.360.3333

ILLINOIS Rochelle
 P 800.659.0745
 F 513.645.0750

MARYLAND Baltimore
 P 410.477.4000
 F 410.477.1550

OHIO Warren—East
 P 330.372.5564
 F 330.372.4055

OHIO Warren—West
 P 330.372.4014
 F 330.372.1945

TEXAS Baytown
 P 281.383.1617
 F 281.573.1679

TEXAS Dallas
 P 214.350.1716
 F 214.350.7252

CLIP EXPRESS™—East
 P 866.638.1908

CLIP EXPRESS™—West
 P 530.406.3462

VINYL CORP.
 P 800.648.4695

ClarkDietrich Engineering Services. A full spectrum of solutions.

Toll-Free Phone: 877.832.3206
 Toll-Free Fax: 877.832.3208
 Technical Services: 888.437.3244
 Email: engineering@clarkdietrich.com

CENTRAL Crown Point, IN

SOUTHEAST Roswell, GA

NORTHEAST Bristol, CT

WEST Carlsbad, CA

SOUTHEAST McDonough, GA

Turn to ClarkDietrich for a complete lineup of steel construction products and services nationwide:

Interior Framing · Exterior Framing · Interior Finishing · Clips/Connectors · Metal Lath/Accessories · Engineering



9100 Centre Pointe Dr. Suite 210
West Chester, OH 45069

P 513.870.1100
F 513.870.1300

clarkdietrich.com
Clarkwestern Dietrich Building Systems LLC

CD-ProSTUD © 4/15 ClarkDietrich Building Systems

The technical content of this literature is effective 4/9/15 and supersedes all previous information.