

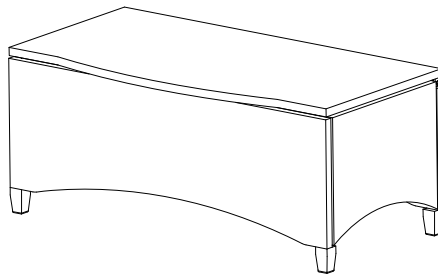

Item #698 980
Model #D13106-TNK

USE AND CARE GUIDE

BOLINGBROOK TRUNK COFFEE TABLE



Questions, problems, missing parts? Before returning to the store,
call Hampton Bay Customer Service
8 a.m. - 7 p.m., EST, Monday-Friday
9 a.m. - 6 p.m. EST, Saturday

1-855-HD-HAMPTON

HAMPTONBAY.COM

THANK YOU

We appreciate the trust and confidence you have placed in Hampton Bay through the purchase of this trunk coffee table. We strive to continually create quality products designed to enhance your home. Visit us online to see our full line of products available for your home improvement needs. Thank you for choosing Hampton Bay!

Table of Contents

Table of Contents.....	2	Hardware Included.....	3
Warranty.....	2	Trunk Coffee Table Package Contents	4
What is Covered	2	Assembly	5
What is Not Covered	2	Care and Cleaning	6
Pre-assembly.....	3		
Planning Assembly.....	3		

Warranty

THIS IS A RESIDENTIAL WARRANTY ONLY AND THIS WARRANTY DOES NOT APPLY TO COMMERCIAL USE

2 YEAR FRAME AND RESIN WEAVE LIMITED WARRANTY

WHAT IS COVERED

We warrant the frame and resin weave to be free of manufacturing defects to the original purchaser for two years.

WHAT IS NOT COVERED

It remains the customer's responsibility for freight and packaging charges to and from our service center.

This warranty does not cover commercial use, hardware, acts of nature, fire, freezing, and abusive use.

In addition, purchased parts are not covered under this warranty. We reserve the right to make substitutions with similar merchandise, if the model in question is no longer in production.

For a copy of our full limited warranty, please contact our customer service team below.

Contact the Customer Service Team at 1-855-HD-HAMPTON or visit www.hamptonbay.com.

Pre-assembly

PLANNING ASSEMBLY

Please read this entire instruction manual prior to assembly.

Identify all parts packed in the carton against the parts list. Remove all protective materials and place the parts on a non-abrasive surface to avoid scratching.



NOTE: More than one person may be required to complete the assembly of this product.

HARDWARE INCLUDED



NOTE: Tools not shown to actual size.

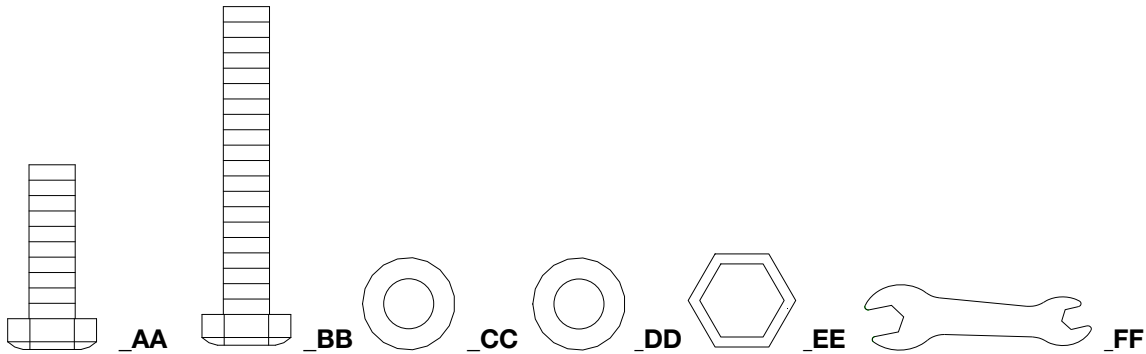

Part	Description	Quantity
AA	M6x20mm Hex bolt	2
BB	M6x40mm Hex bolt	8
CC	1mm thickness washer	10
DD	3mm thickness washer	2
EE	M6 Hex bolt cap	10
FF	M6-M8 Hex Wrench	1

Pre-assembly

TRUNK COFFEE TABLE PACKAGE CONTENTS

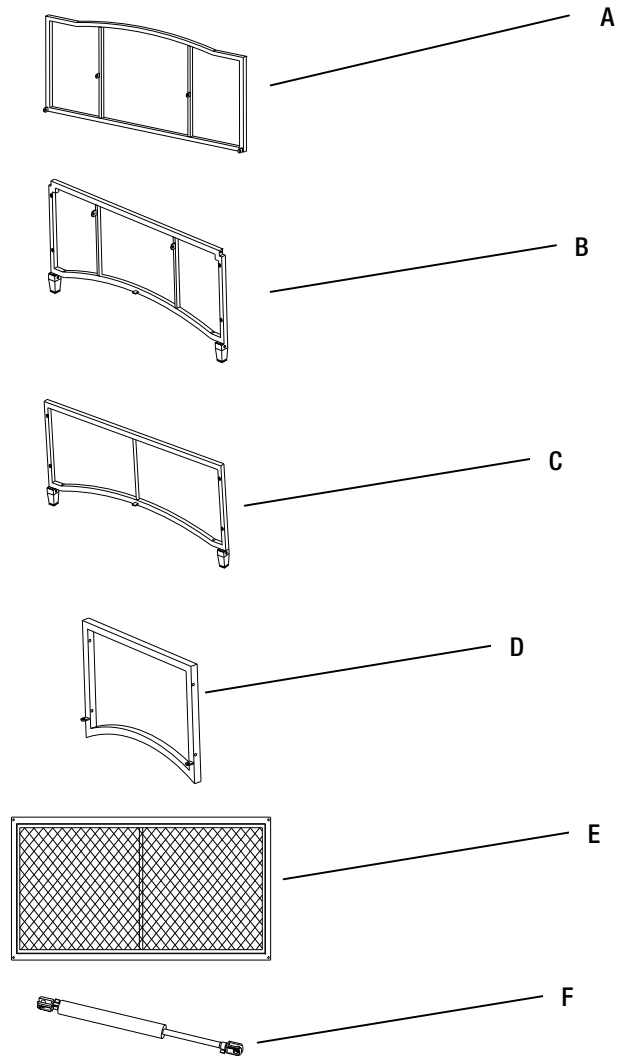

Part	Description	Quantity
A	Top panel	1
B	Back panel	1
C	Front panel	1
D	Side panel	2
E	Bottom steel mesh	1
F	Air pump	2

Assembly

1 Attaching the side panels

- Attach the side panels (D) to the back panel (B) with the M6x40mm hex bolts (BB) and M6 washers (CC).
- Tighten all bolts and cover with bolt caps (EE).



NOTE: Please ensure all M6 hex bolts are assembled correctly and use the M6-M8 wrench (FF) to tighten.

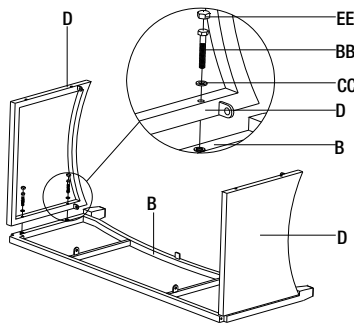

3 Attaching the top panel

- Attach the top panel (A) to back panel (B) using the M6x20MM hex bolts (AA) and washers (CC) and (DD).
- Tighten all bolts with the wrench (FF), and cover with bolt caps (EE).

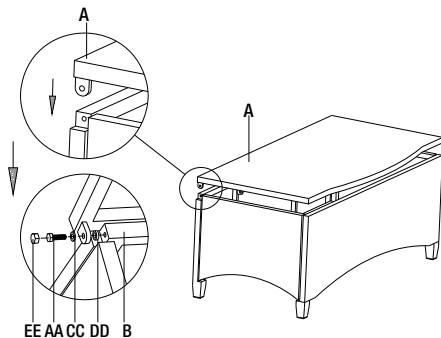

2 Inserting the bottom steel mesh and attaching the front panel

- Insert the bottom steel mesh (E) to the side panels (D).
- Attach the front panel (C) to side panels (D) with the M6x40mm hex bolts (BB) and washers (CC).
- Tighten all bolts with the wrench (FF) and attach bolt caps (EE).

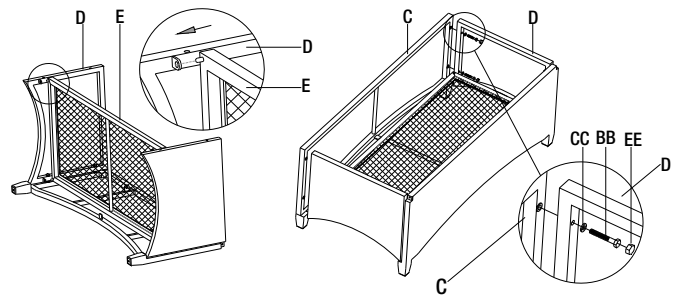

4 Attaching the air pump

- Attach the air pumps (F) to the top panel (A) and back panel (B) at the 2 welded grommets on each.
- The trunk coffee table is now ready for use.

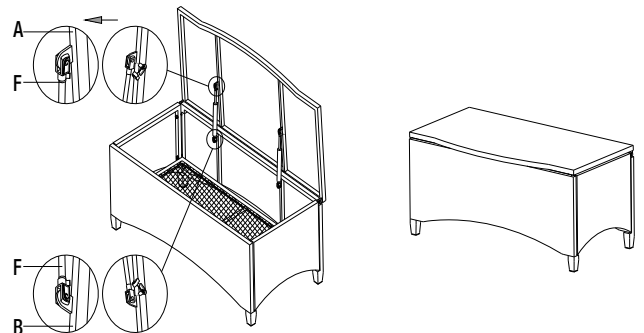

Care and Cleaning

- Do not allow water to build up in the frames. This will cause corrosion and possible freezing damage in cold climates.
- Use a mild soap and water for normal cleaning. Do not use janitorial or alcohol based cleaners. Some cleaners may be marked as natural, but some ingredients may cause discoloration or have an adverse reaction to your finish.
- Rinse with clean water and dry with a soft, absorbent cloth towel.
- Treat frames with a liquid wax for maximum protection against UV rays and/or salty, damp air.



Questions, problems, missing parts? Before returning to the store,
call Hampton Bay Customer Service
8 a.m. - 7 p.m., EST, Monday-Friday
9 a.m. - 6 p.m. EST, Saturday

1-855-HD-HAMPTON

HAMPTONBAY.COM

Retain this manual for future use.