



MUSTEE FLOOR MOUNTED LAUNDRY TRAY



MODEL:		
15F (15FK)		IAPMO® LISTED FILE NO. 0635
* 17F (17FK)		IAPMO® LISTED FILE NO. 0820
* 18F (18FK)		IAPMO® LISTED FILE NO. 0820
19F (19FK)		IAPMO® LISTED FILE NO. 0635

*Models made with Durastone™

NOTE:

Any type of transfer or sump pump must be supported by the floor or wall plus appropriate bracing for the waste lines. DO NOT RELY SOLELY ON THE 1-1/2" MOLDED DRAIN THREAD CONNECTION.

MODEL 15F (15FK) and 17F (17FK):

Turn Laundry Tray upside down on a smooth, clean surface to allow for the removal of the 1" (inch) diameter faucet hole plugs which are located on 4" (inch) centers. Be sure to allow for rear ledge overhang – approximately 5/8" – this will give more support to the ledge area. The hole plugs may be removed by drilling with a 1" (inch) diameter hole saw.

MODEL 18F (18FK):

The rear ledge of your Model 18F (18FK) Laundry Tray will accept many different faucets; 4" Center Set on center, 4" Center Set either right or left, 8" Center Set on center. Depending on the model faucet you choose, the appropriate holes will have to be drilled. You will notice that there are five indented hole locators molded-in on the underside of the rear ledge. Do not cut out faucet holes until you have measured the actual faucet you intend to use. Some single lever faucets require a large center/supply hole and small diameter mounting holes. A 1" diameter, fine tooth hole saw with center drill pilot would normally be used for the majority of faucet hole drilling. Drill from underside of rear ledge to mark center. Turn upright to finish cutting with hole saw.

MODEL 19F (19FK):

The one inch (1") diameter faucet holes are prepunched on four inch (4") centers.

1. Insert Leg into corner socket. Using a block of wood or similar pad to protect the end of the leg, strike with hammer to drive leg into tapered socket. To determine if leg is properly installed, measure the corner gap. 1/16" maximum clearance is recommended to insure that the leg is locked securely into the tapered socket. Repeat above procedure for remaining legs.
2. Mount Leveler to leg. Note that there are two holes in the bottom of leg. Select the proper hole that will allow access to the screwhead after the tray is in desired location. Repeat above procedure for remaining legs.
3. Mount faucet (not furnished) on tray. If a "clamp-on" style faucet is preferred, optional Faucet Block Part No. 20.600 is available.
4. Position tray in desired location. Check level and adjust as needed with levelers (see FIG. 1). Holes are punched in levelers if anchoring tray to floor is desired (anchors not furnished).
5. Make final water supply and sanitary drain connections in full compliance with local code requirements.

Cleaning Note:

Most stains that you may acquire in your Laundry Tray may be removed with common household cleanser or liquid cleaner. Stubborn stains may be removed with a bleach solution. Follow bleach manufacturer's recommended procedures pertaining to safety, handling and use of their product.

MODELS: 15F (15FK), 17F (17FK), 18F, (18FK) and 19F (19FK)

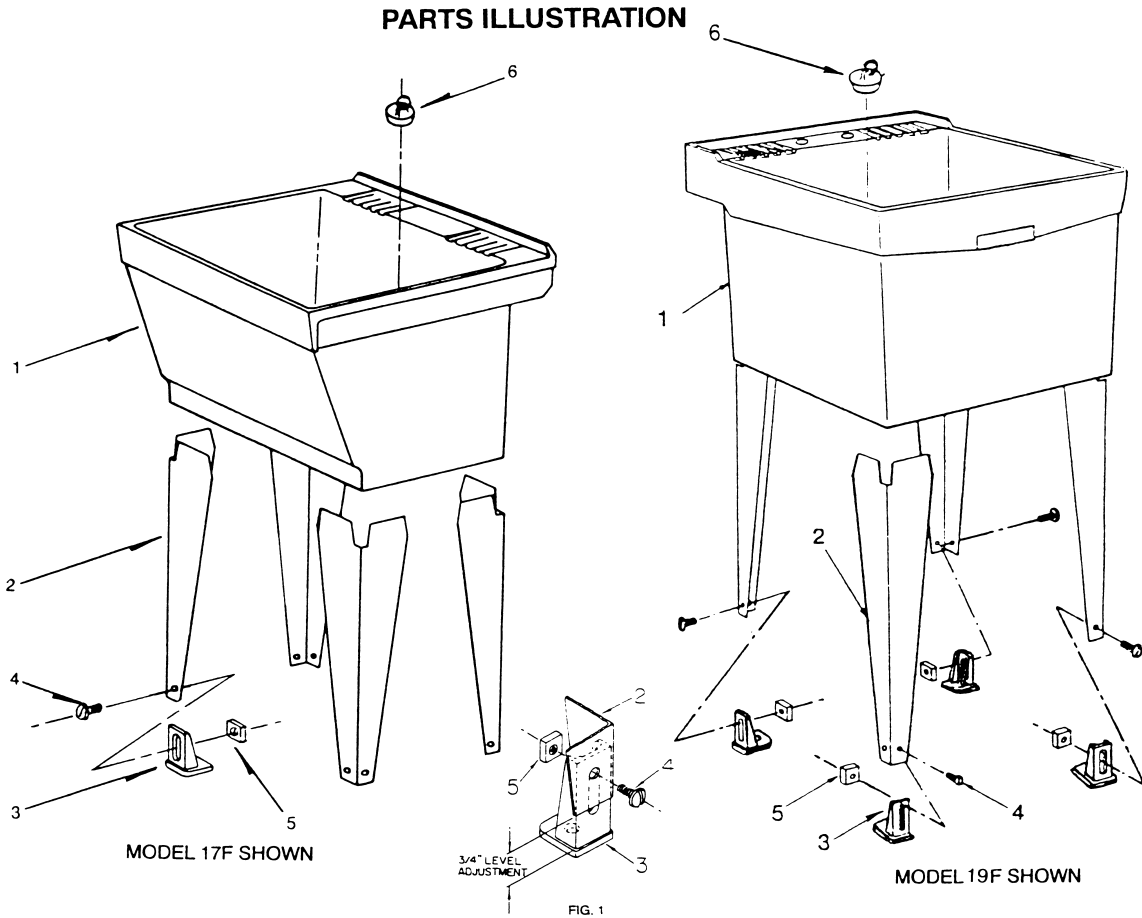

PARTS LIST					DESCRIPTION
KEY NO.	PART NO.				
	15F (15FK)	17F (17FK)	18F (18FK)	19F (19FK)	
1	15.101	17.102	18.101	19.101	LAUNDRY TRAY
2	18.301	18.301	18.301	18.301	LEG (4 REQ'D)
3	18.305*	18.305*	18.305*	18.305*	LEVELER (4 REQ'D)
4	*	*	*	*	LEVELER SCREW, 1/4" - 20NC X 1/2" (4 REQ'D)
5	*	*	*	*	NUT, 1/4" - 20NC (4 REQ'D)
6	*	*	*	*	STOPPER, 1-1/2" DIAMETER
7	*	*	*	*	1-1/2" SLIP NUT WASHER (NOT SHOWN)
8	*	*	*	*	1-1/2" THRD., SLIP NUT (NOT SHOWN)

*NOTE: FOR REPLACEMENT HARDWARE, ORDER COMPLETE PARTS PACKAGE
PART NO. 18.603 — PACKAGES WILL NOT BE SPLIT FOR INDIVIDUAL PARTS

UTILATOP™ Laundry Tray Cover **PART NO. 19.204 (Order Separately)**

Heavy-duty, molded thermoplastic top fits Model 18 F/W and 19 F/W tubs.

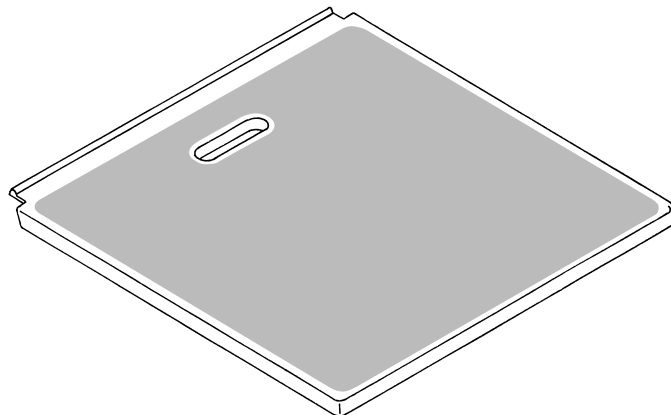

E.L. MUSTEE & SONS, INC.

5431 West 164th Street • Brook Park, Ohio 44142

SI-177 (04•06)