

# GOLD'S GYM®

## STRIDE TRAINER 550i

getgoldsgym.com

Model No. GGEL65916.2

Serial No. \_\_\_\_\_

Write the serial number in the space above for reference.

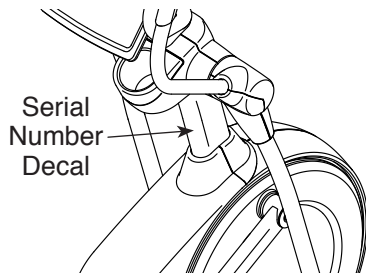

### ACTIVATE YOUR WARRANTY

To register your product and activate your warranty today, go to [my.getgoldsgym.com](http://my.getgoldsgym.com).

### CUSTOMER CARE

For service at any time, go to [getgoldsgym/service.com](http://getgoldsgym/service.com).

Or call 1-877-776-4777  
Mon.–Fri. 6 a.m.–6 p.m. MT  
Sat. 8 a.m.–12 p.m. MT

Please do not contact the store.

### ⚠ CAUTION

Read all precautions and instructions in this manual before using this equipment. Keep this manual for future reference.

## USER'S MANUAL

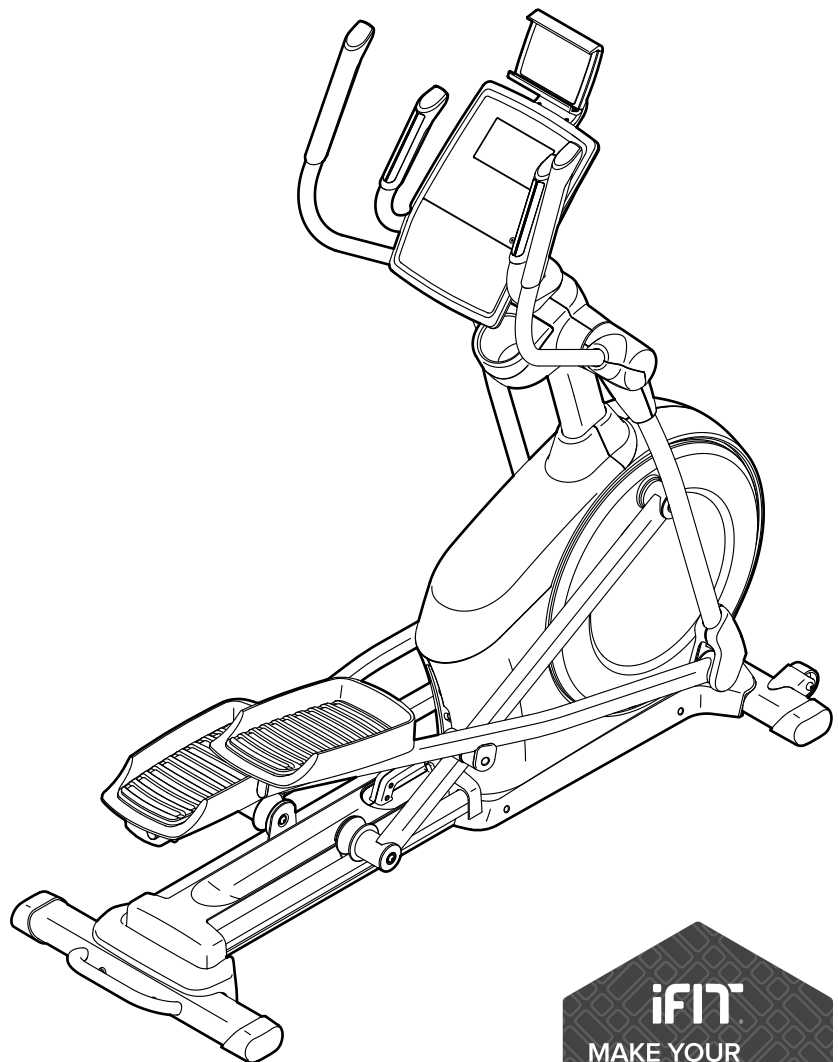

# TABLE OF CONTENTS

WARNING DECAL PLACEMENT .....	2
IMPORTANT PRECAUTIONS.....	3
BEFORE YOU BEGIN.....	5
PART IDENTIFICATION CHART.....	6
ASSEMBLY.....	7
HOW TO USE THE ELLIPTICAL .....	17
FCC INFORMATION .....	25
MAINTENANCE AND TROUBLESHOOTING.....	26
EXERCISE GUIDELINES .....	28
PART LIST.....	31
EXPLODED DRAWING.....	33
ORDERING REPLACEMENT PARTS .....	Back Cover
LIMITED WARRANTY.....	Back Cover

## WARNING DECAL PLACEMENT

This drawing shows the location(s) of the warning decal(s). **If a decal is missing or illegible, see the front cover of this manual and request a free replacement decal. Apply the decal in the location shown.** Note: The decal(s) may not be shown at actual size.

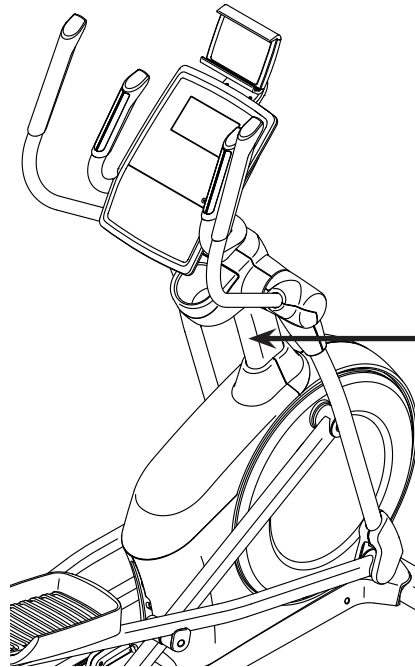

**▲ WARNING**

- Misuse of this machine may result in serious injury.
- Read user's manual prior to use and follow all warnings and instructions.
- Do not allow children on or around machine.
- Pedals continue to spin when you stop pedaling.
- Spinning pedals can cause injury.
- Reduce pedal speed in a controlled manner.
- User weight must not exceed 300 lbs / 136 kgs.
- This product should always be used on a level surface.
- This product is not intended for therapeutic use.
- Replace label if damaged, illegible, or removed.

GOLD'S GYM is a registered trademark of Gold's Gym International, Inc. This product is manufactured and distributed under license from Gold's Gym Merchandising, Inc. IFIT is a registered trademark of ICON Health & Fitness, Inc. App Store is a trademark of Apple Inc., registered in the U.S. and other countries. Android and Google Play are trademarks of Google Inc. The BLUETOOTH® word mark and logos are registered trademarks of Bluetooth SIG, Inc. and are used under license. IOS is a trademark or registered trademark of Cisco in the U.S. and other countries and is used under license.

---

# IMPORTANT PRECAUTIONS

**⚠️ WARNING:** To reduce the risk of serious injury, read all important precautions and instructions in this manual and all warnings on your elliptical before using your elliptical. ICON assumes no responsibility for personal injury or property damage sustained by or through the use of this product.

1. It is the responsibility of the owner to ensure that all users of the elliptical are adequately informed of all precautions.
2. Before beginning any exercise program, consult your physician. This is especially important for persons over age 35 or persons with pre-existing health problems.
3. The elliptical is not intended for use by persons with reduced physical, sensory, or mental capabilities or lack of experience and knowledge, unless they are given supervision or instruction about use of the elliptical by someone responsible for their safety.
4. Use the elliptical only as described in this manual.
5. The elliptical is intended for home use only. Do not use the elliptical in a commercial, rental, or institutional setting.
6. Keep the elliptical indoors, away from moisture and dust. Do not put the elliptical in a garage or covered patio, or near water.
7. Place the elliptical on a level surface, with at least 3 ft. (0.9 m) of clearance in the front and rear of the elliptical and 2 ft. (0.6 m) on each side. To protect the floor or carpet from damage, place a mat under the elliptical.
8. Inspect and properly tighten all parts each time the elliptical is used. Replace any worn parts immediately.
9. Keep children under age 13 and pets away from the elliptical at all times.
10. The elliptical should not be used by persons weighing more than 300 lbs. (136 kg).
11. Wear appropriate clothes while exercising; do not wear loose clothes that could become caught on the elliptical. Always wear athletic shoes for foot protection while exercising.
12. Hold the handlebars or the upper body arms when mounting, dismounting, or using the elliptical.
13. The heart rate monitor is not a medical device. Various factors may affect the accuracy of heart rate readings. The heart rate monitor is intended only as an exercise aid in determining heart rate trends in general.
14. The elliptical does not have a freewheel; the pedals will continue to move until the flywheel stops. Reduce your pedaling speed in a controlled way.
15. Keep your back straight while using the elliptical; do not arch your back.
16. Over exercising may result in serious injury or death. If you feel faint, if you become short of breath, or if you experience pain while exercising, stop immediately and cool down.

# PROTECT

YOUR FITNESS EQUIPMENT  
WITH AN EXTENDED SERVICE PLAN

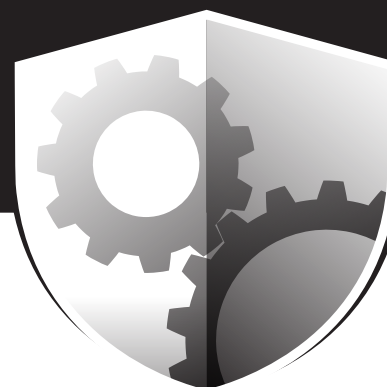

Your new fitness equipment is not an ordinary purchase; it is an investment in your health and well being for years to come.

As the leading provider of manufacturer's extended service plans, ICON strives to protect your equipment and your future.

Please review the following service plans and find one that best fits your needs.

## PREVENTIVE MAINTENANCE SERVICE PLANS

Equipment Price	3-Year Plan	5-Year Plan
\$0.00 to \$1000.00	\$199.99	\$289.99
\$1001.00 to \$1500.00	\$259.99	\$379.99
\$1501.00 to \$2500.00	\$339.99	\$489.99
(Bikes/Systems Only) \$0.00 to \$2500.00	\$139.99	NA

Features:

- Includes an annual preventive maintenance and performance check at your convenience
- Unlimited in-home repairs; no shipping required
- Covers parts and labor on all manufacturer's defects, as well as wear and tear on parts
- Up to 5 years of coverage available

## STANDARD SERVICE PLANS

Equipment Price	1-Year Plan	2-Year Plan	3-Year Plan
\$0.00 to \$300.00	\$29.99	\$39.99	\$59.99
\$301.00 to \$1000.00	\$89.99	\$119.99	\$149.99
\$1001.00 to \$2000.00	\$109.99	\$139.99	\$179.99
\$2001.00 to \$3000.00	\$179.99	\$209.99	\$239.99

Features:

- Unlimited in-home repairs; no shipping required
- Covers parts and labor on all manufacturer's defects, as well as wear and tear on parts
- Up to 3 years of coverage available

To protect your fitness equipment today, please  
call Customer Care at **1-800-677-3838.**  
Or, visit us online at **www.utserv.com.**



# BEFORE YOU BEGIN

Thank you for selecting the revolutionary GOLD'S GYM® STRIDE TRAINER 550I elliptical. The STRIDE TRAINER 550I elliptical provides an impressive selection of features designed to make your workouts at home more effective and enjoyable.

**For your benefit, read this manual carefully before you use the elliptical.** If you have questions after

reading this manual, please see the front cover of this manual. To help us assist you, note the product model number and serial number before contacting us. The model number and the location of the serial number decal are shown on the front cover of this manual.

Before reading further, please familiarize yourself with the parts that are labeled in the drawing below.

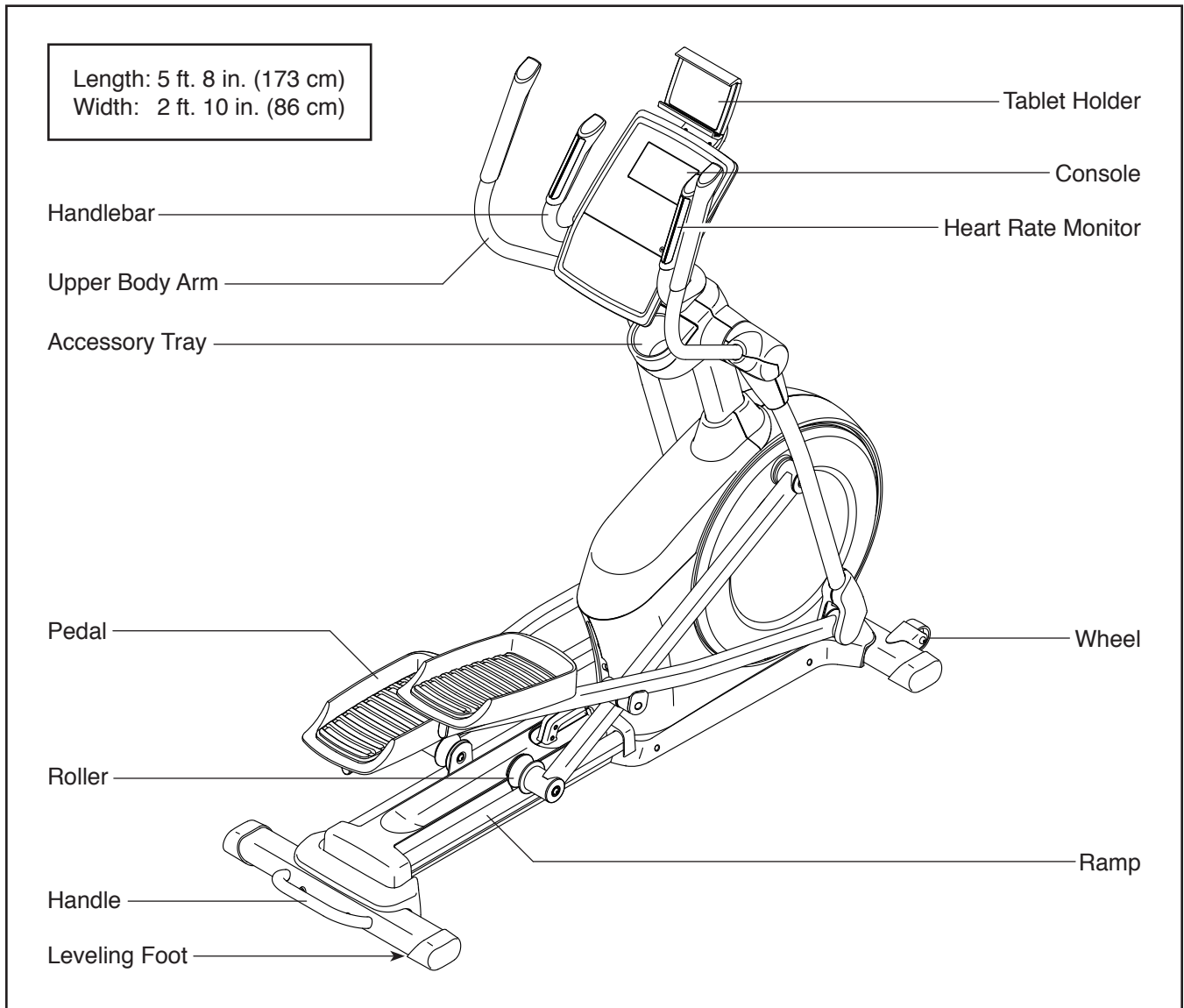

# PART IDENTIFICATION CHART

Use the drawings below to identify the small parts needed for assembly. The number in parentheses below each drawing is the key number of the part, from the PART LIST near the end of this manual. The number following the key number is the quantity needed for assembly. **Note: If a part is not in the hardware kit, check to see if it has been preassembled. Extra parts may be included.**

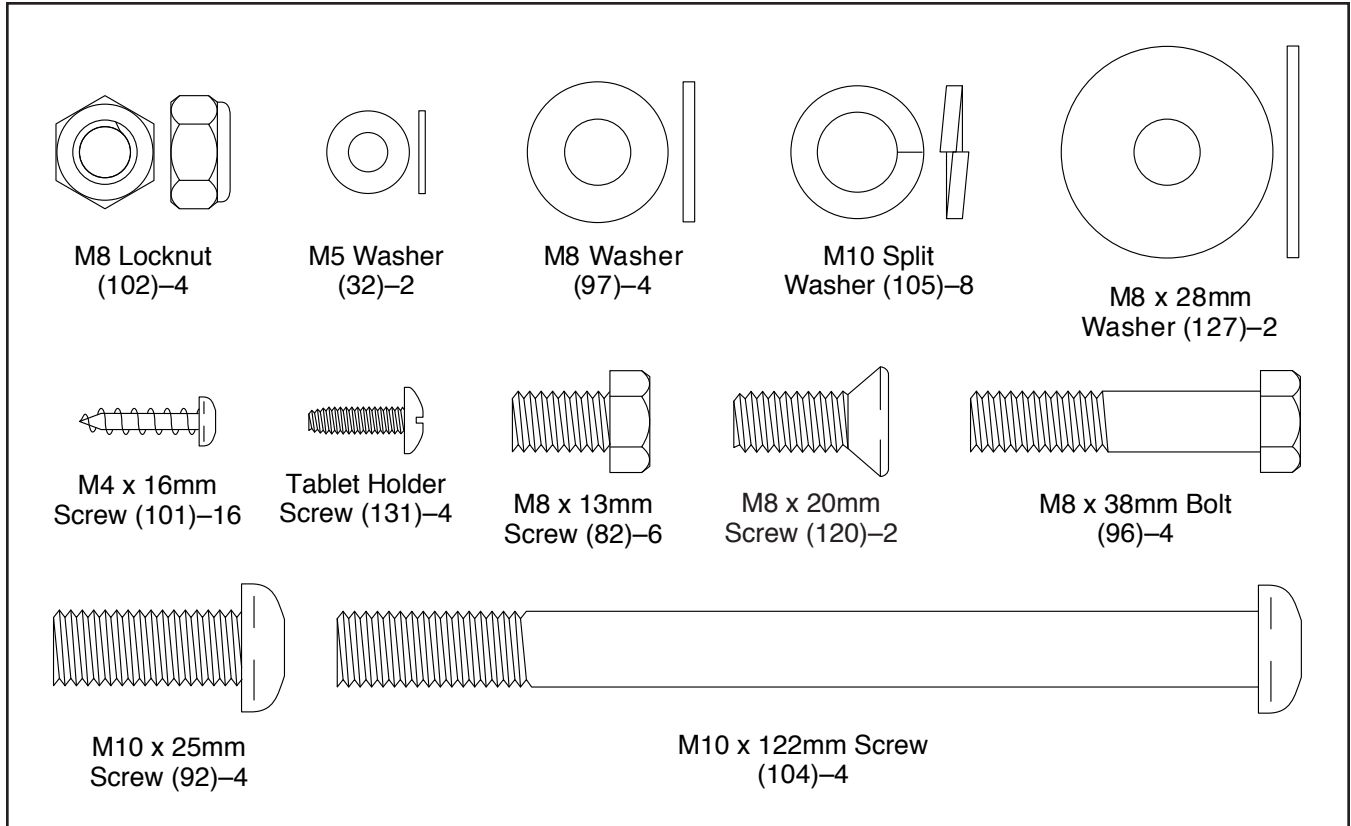

# ASSEMBLY

- To hire an authorized service technician to assemble this product, call 1-800-445-2480.
- Assembly requires two persons.
- Place all parts in a cleared area and remove the packing materials. Do not dispose of the packing materials until you finish all assembly steps.
- Left parts are marked “L” or “Left” and right parts are marked “R” or “Right.”
- To identify small parts, see page 6.

- In addition to the included tool(s), assembly requires the following tools:

one Phillips screwdriver 

two adjustable wrenches 

one rubber mallet 

Assembly may be easier if you have a set of wrenches. To avoid damaging parts, do not use power tools.

## 1. Go to [my.getgoldsgym.com](http://my.getgoldsgym.com) on your computer and register your product.

- activates your warranty
- saves you time if you ever need to contact Customer Care
- allows us to notify you of upgrades and offers

Note: If you do not have internet access, call Customer Care (see the front cover of this manual) and register your product.

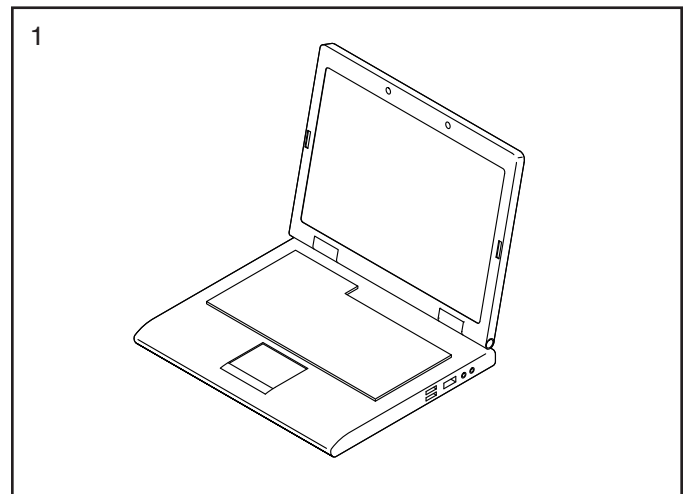

## 2. With the help of a second person, place some of the packing materials (not shown) under the rear of the Frame (1). **Have the second person hold the Frame to prevent it from tipping while you complete this step.**

Attach the Rear Stabilizer (2) to the Frame (1) with two M10 x 122mm Screws (104) and two M10 Split Washers (105).

Then, remove the packing materials from under the rear of the Frame (1).

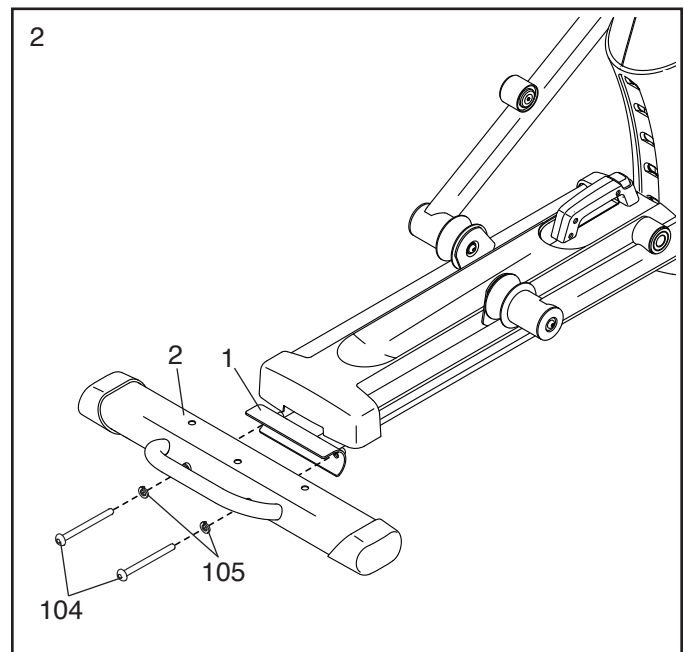

3. Press the Cover Mounts (106) on the underside of the Rear Stabilizer Cover (15) into the Rear Stabilizer (2).

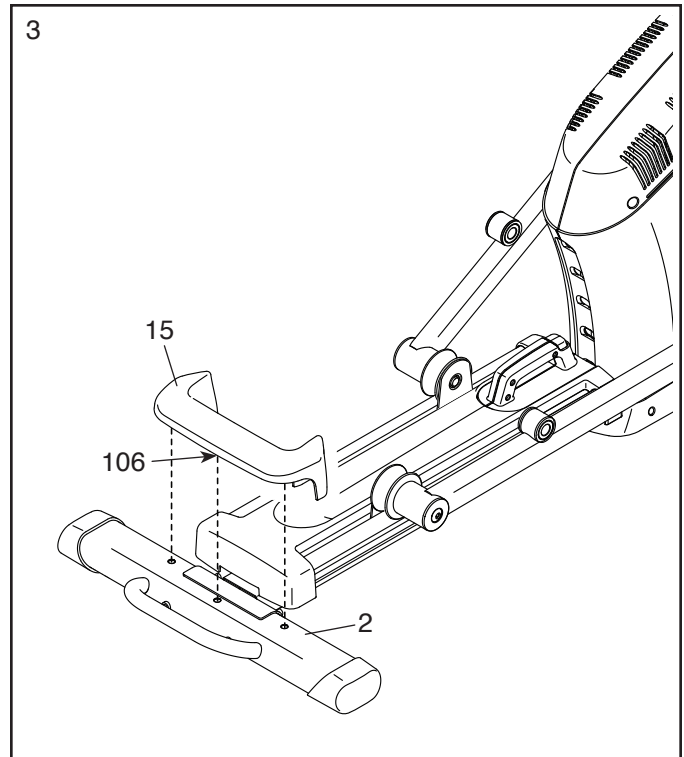

4. With the help of a second person, place some of the packing materials (not shown) under the front of the Frame (1). **Have the second person hold the Frame to prevent it from tipping while you complete this step.**

Attach the Front Stabilizer (6) to the Frame (1) with two M10 x 122mm Screws (104) and two M10 Split Washers (105).

Then, remove the packing materials from under the front of the Frame (1).

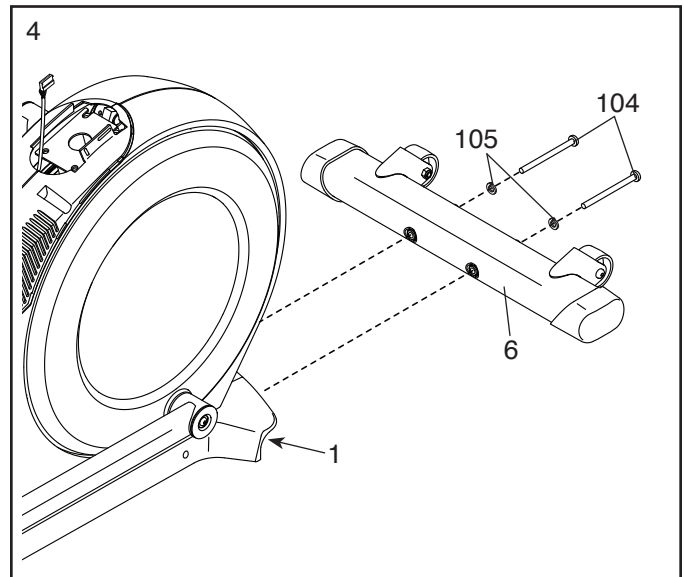



5. **Tip: Avoid pinching the Upper Wire (110). Avoid damaging the indicated plastic tabs (A).** Have a second person hold the Upright (4) on the Frame (1).

Attach the Upright (4) with four M10 x 25mm Screws (92) and four M10 Split Washers (105); **start all the Screws, and then tighten them.**

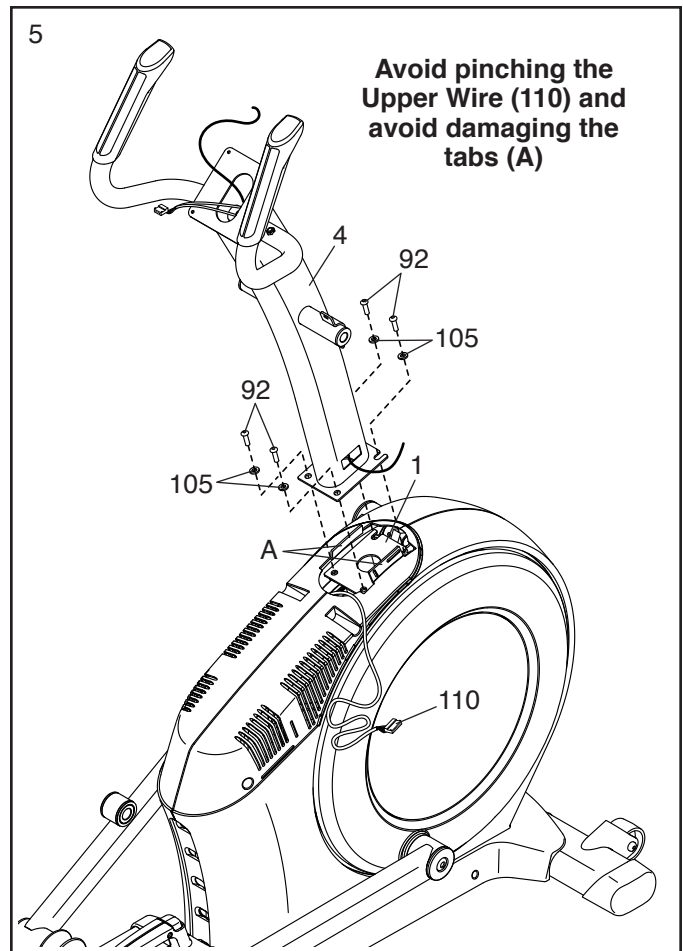

6. **See the inset drawing.** Locate the wire tie (B) in the lower end of the Upright (4). Tie the wire tie to the Upper Wire (110). Then, pull the upper end of the wire tie until the Upper Wire is routed through the Upright.

**Tip: To prevent the Upper Wire (110) from falling into the Upright (4), secure the Upper Wire with the wire tie (B).**

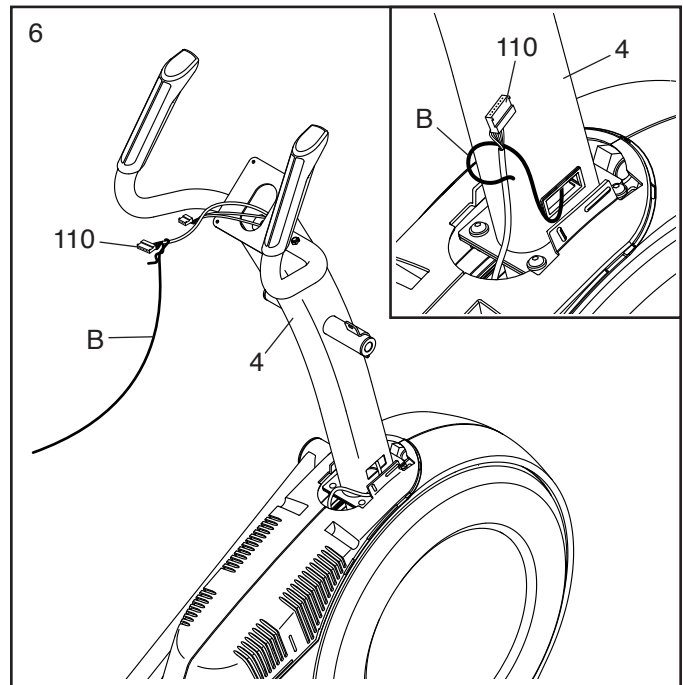

7. Using a plastic bag to keep your fingers clean, apply some of the included grease to the Pivot Axle (35).

Insert the Pivot Axle (35) through the Upright (4) and center it. **Tip: It may be helpful to use a rubber mallet.**

Next, slide a Pivot Spacer (54) onto the right side of the Pivot Axle (35).

Then, identify the Right Upper Body Leg (60), orient it as shown, and slide it onto the right side of the Pivot Axle (35).

**Repeat these actions for the Left Upper Body Leg (46).**

Then, tighten an M8 x 13mm Screw (82) with an M8 x 28mm Washer (127) into each end of the Pivot Axle (35) **at the same time.**

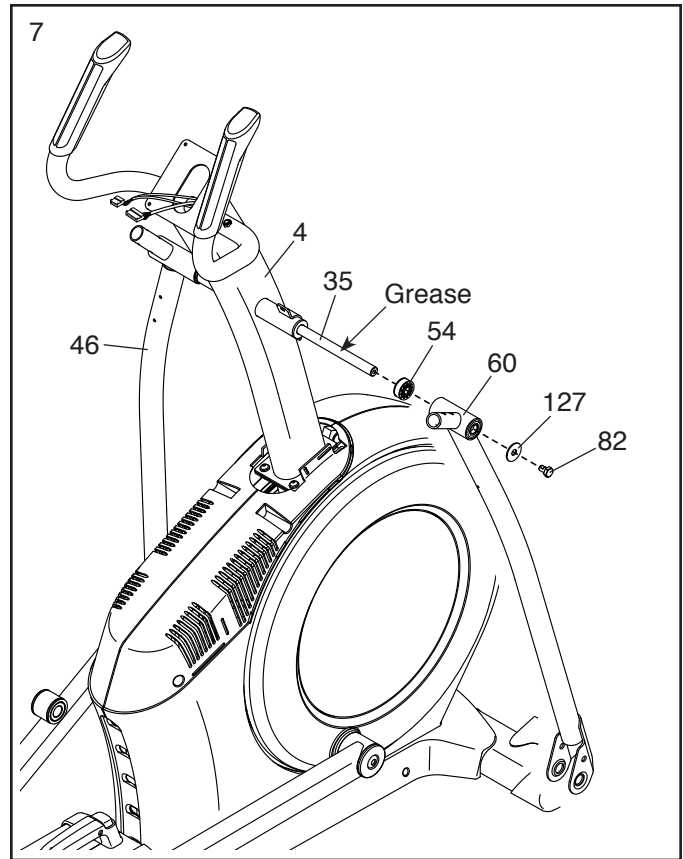

8. Identify the Right Upper Body Arm (61), orient it as shown, and slide it onto the Right Upper Body Leg (60).

Attach the Right Upper Body Arm (61) with two M8 x 38mm Bolts (96) and two M8 Locknuts (102); **make sure that the Locknuts are in the hexagonal holes (C).**

**Repeat this step for the Left Upper Body Arm (47).**

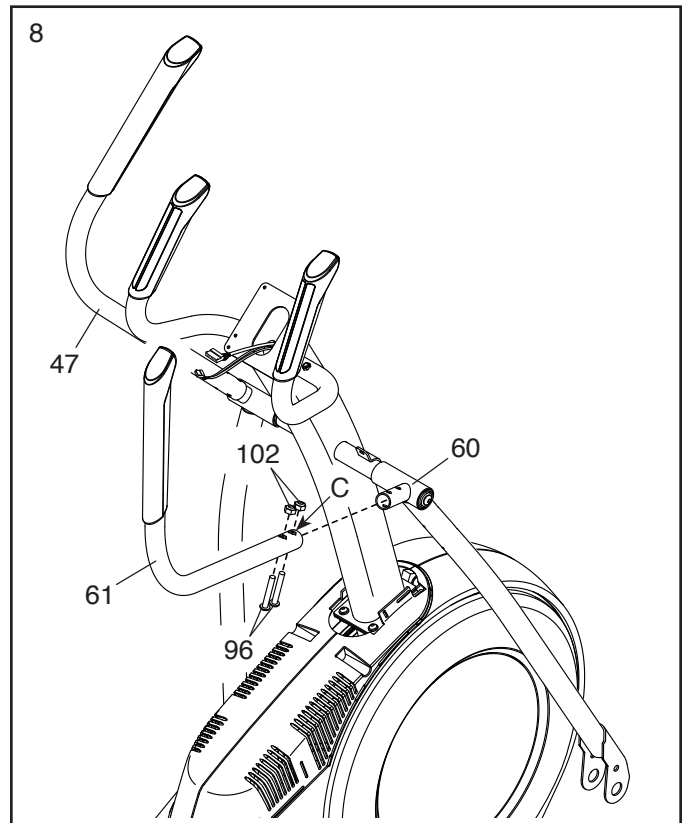

9. Untie and discard the wire tie on the Upper Wire (110).

While a second person holds the Console (7) near the Upright (4), connect the wires on the Console to the Upper Wire (110) and to the Pulse Sensor Wires (63).

Insert the excess wire into the Upright (4) or into the Console (7).

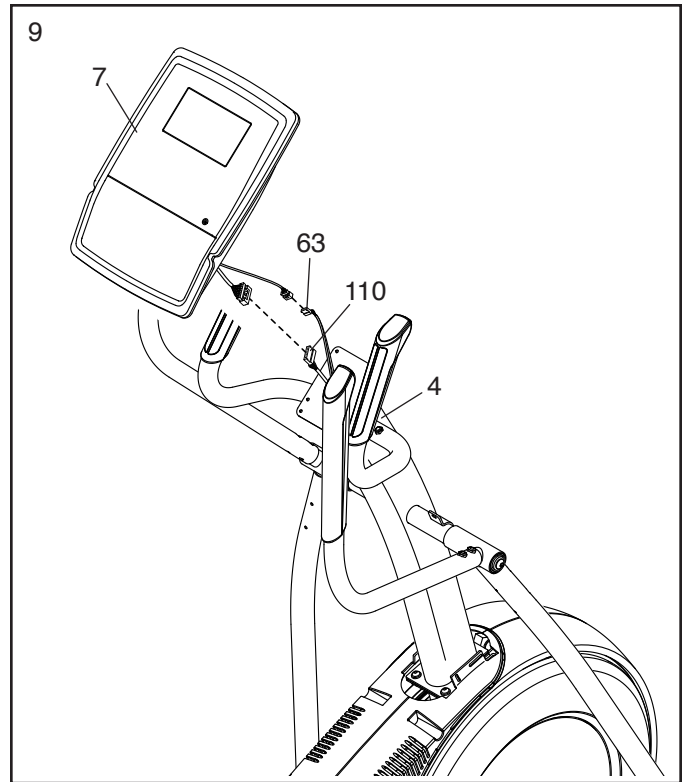

10. **Tip: Avoid pinching the wires.** Attach the Console (7) to the Upright (4) with four M4 x 16mm Screws (101); **start all the Screws, and then tighten them.**

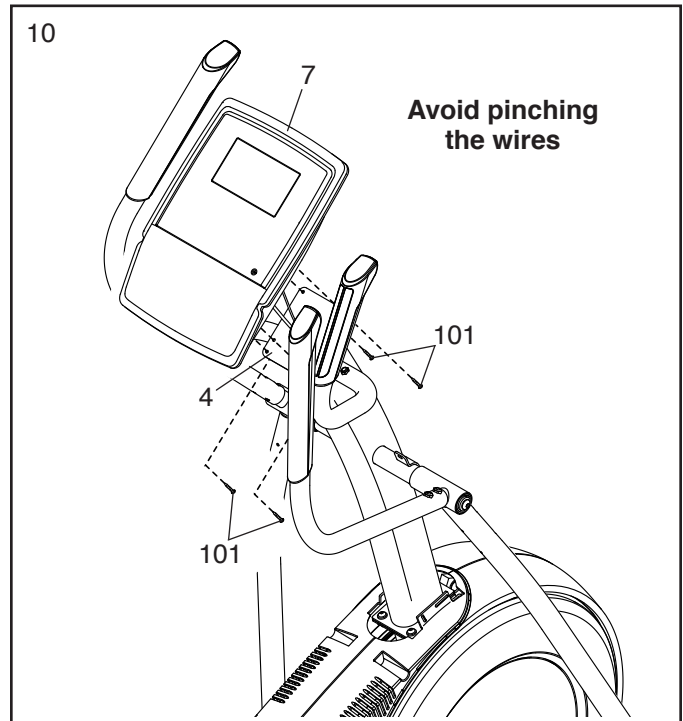

11. Orient the Right Pedal Arm (58) as shown, and then apply grease to the axle.

Attach the Right Pedal Arm (58) to the Right Roller Arm (59) with an M8 x 20mm Screw (120) and a Retainer (55); **make sure that the flat side (D) of the Retainer is facing the Right Roller Arm.**

**Repeat this step for the Left Pedal Arm (44).**

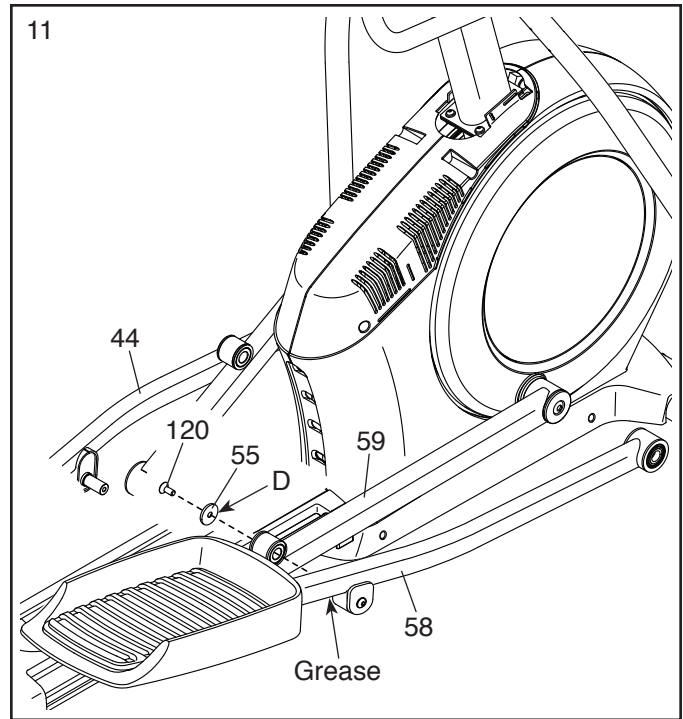

12. Apply a small amount of grease to one of the Pedal Arm Axles (64).

Next, slide an M8 Washer (97) onto an M8 x 13mm Screw (82), and tighten the Screw a few turns into the Pedal Arm Axle (64).

While a second person holds the front end of the Right Pedal Arm (58) inside the bracket on the Right Upper Body Leg (60), insert the Pedal Arm Axle (64) into both parts.

Slide an M8 Washer (97) onto another M8 x 13mm Screw (82), and tighten the Screw a few turns into the Pedal Arm Axle (64). **Then, tighten both Screws at the same time.**

**Repeat this step on the other side of the elliptical.**

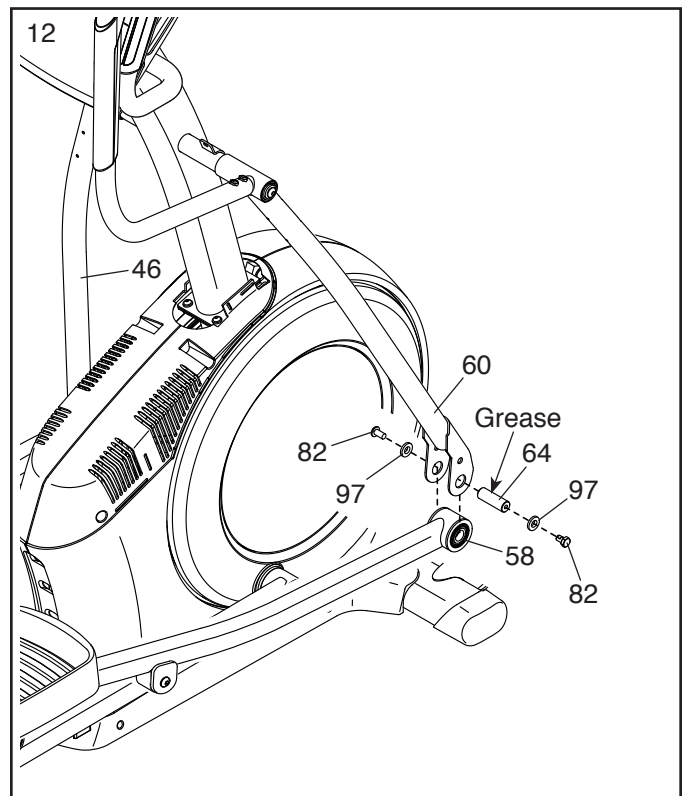

13. Orient the Rear Upright Cover (81) as shown, and attach it to the Upright (4) with four M4 x 16mm Screws (101); **start all the Screws, and then tighten them.**

Orient the Front Upright Cover (117) as shown and press it onto the Rear Upright Cover (81).

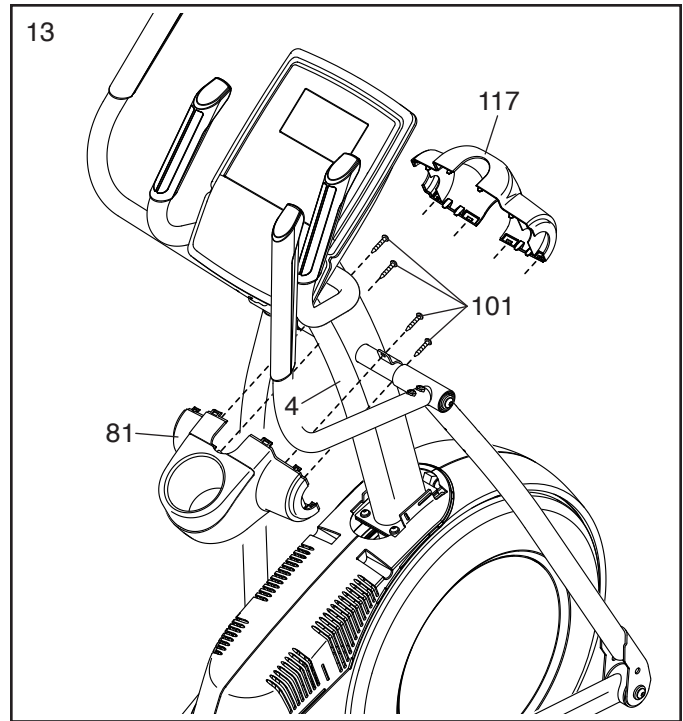

14. Identify the Right Arm Front Cover (65), orient it as shown, and attach it to the Right Upper Body Leg (60) with an M4 x 16mm Screw (101).

Next, identify the Right Arm Rear Cover (66), orient it as shown, and press it onto the Right Arm Front Cover (65).

**Repeat this step on the other side of the elliptical.**

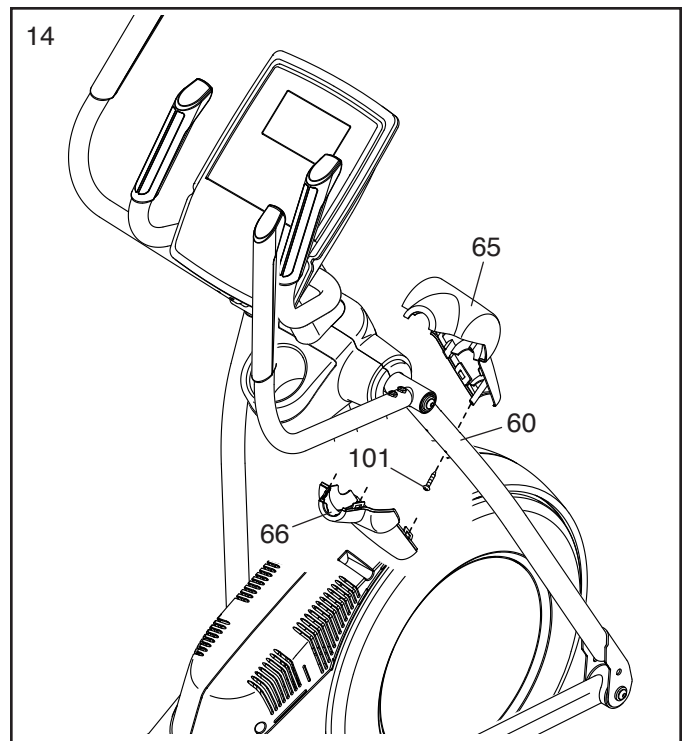

15. Identify the Right Leg Inner Cover (83), orient it as shown, and attach it to the Right Upper Body Leg (60) with an M4 x 16mm Screw (101) and an M5 Washer (32).

Next, identify the Right Leg Outer Cover (69), orient it as shown, and press it onto the Right Leg Inner Cover (83).

**Repeat this step on the other side of the elliptical.**

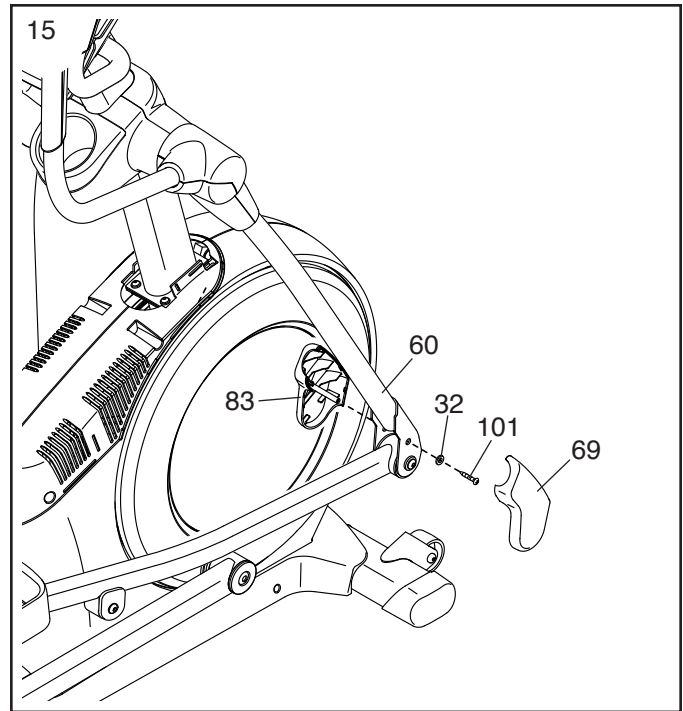

16. Orient the Shield Cover Cap (118) and the Shield Cover (75) as shown.

First, press the Shield Cover Cap (118) into the Left and Right Shields (73, 74).

Then, press the Shield Cover (75) into the Left and Right Shields (73, 74).

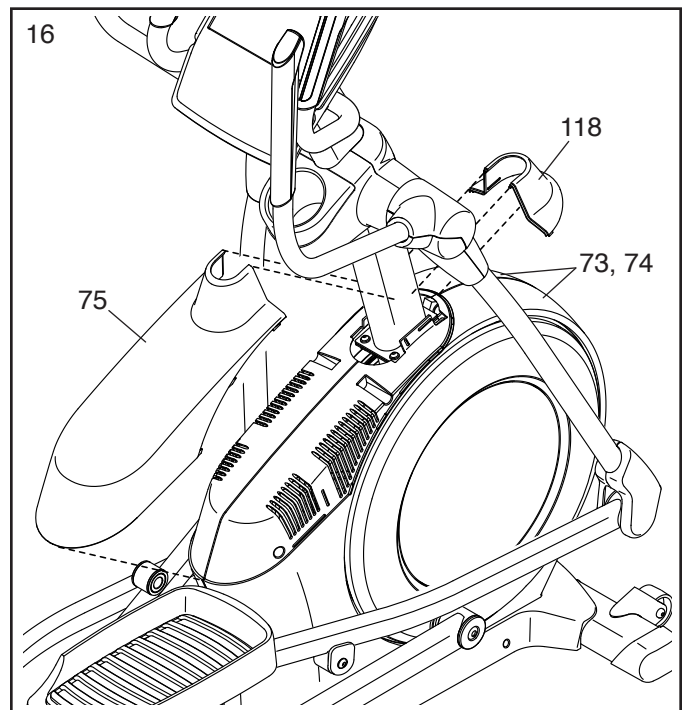

17. Orient the Rear Console Cover (80) as shown and attach it to the Upright (4) with two M4 x 16mm Screws (101).

Next, orient the Front Console Cover (79) as shown and attach it to the Rear Console Cover (80) with two M4 x 16mm Screws (101).

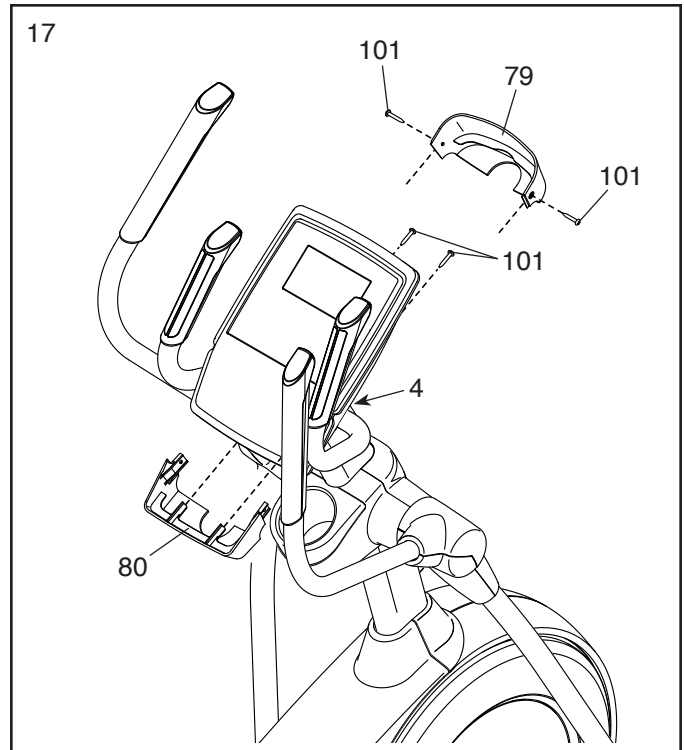

18. Attach the Tablet Holder (130) to the Console (131) with four Tablet Holder Screws (9); **start all the Screws, and then tighten them.**

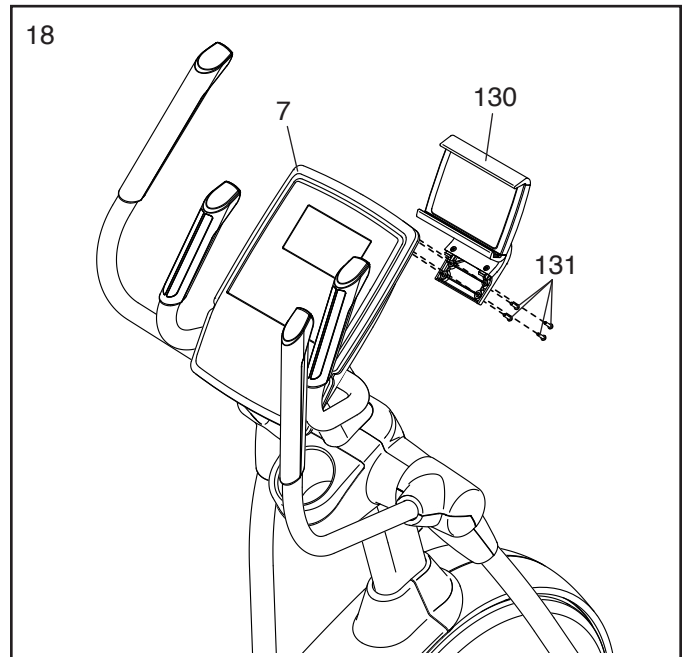

19. Plug the Power Adapter (119) into the receptacle on the frame of the elliptical.

Note: To plug the Power Adapter (119) into an outlet, see HOW TO PLUG IN THE POWER ADAPTER on page 17.

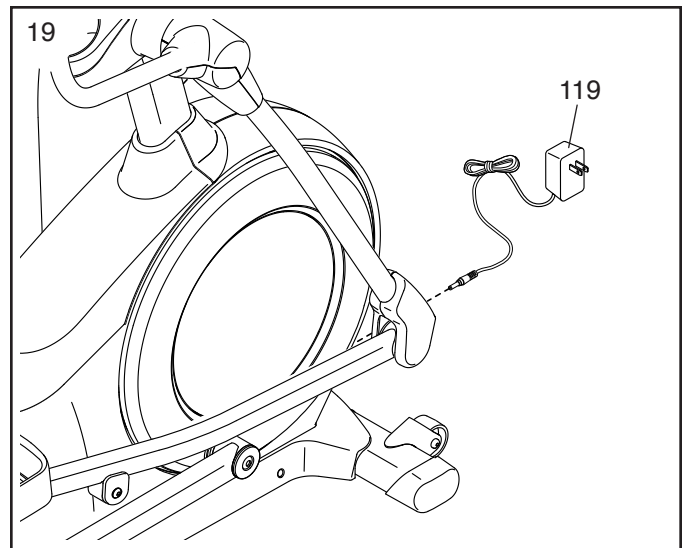

20. **Make sure that all parts are properly tightened before you use the elliptical.** Extra parts may be included. Place a mat beneath the elliptical to protect the floor.



# HOW TO USE THE ELLIPTICAL

## HOW TO PLUG IN THE POWER ADAPTER

**IMPORTANT:** If the elliptical has been exposed to cold temperatures, allow it to warm to room temperature before you plug in the power adapter. If you do not do this, you may damage the console displays or other electronic components.

Plug the power adapter (A) into the receptacle on the front of the elliptical. Then, plug the power adapter into an appropriate outlet that is properly installed in accordance with all local codes and ordinances.

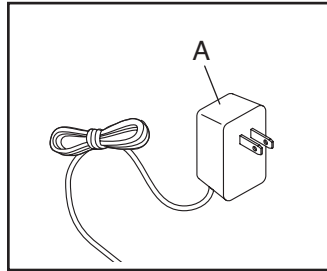

## HOW TO LEVEL THE ELLIPTICAL

If the elliptical rocks slightly on your floor during use, turn one or both of the leveling feet (E) beneath the rear of the frame or turn the leveling foot (F) under the center of the frame until the rocking motion is eliminated.

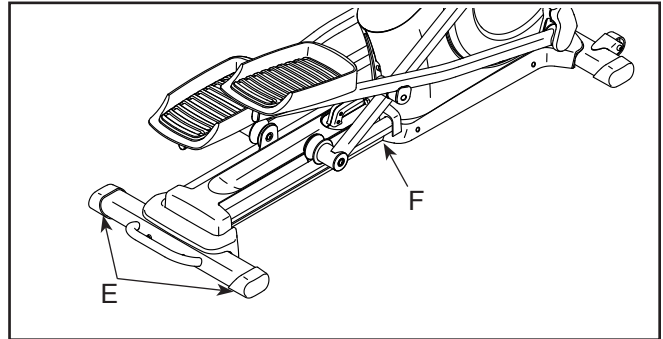

## HOW TO MOVE THE ELLIPTICAL

Due to the size and weight of the elliptical, moving it requires two persons. Stand in front of the elliptical, hold the upright (B), and place one foot against one of the wheels (C). Pull on the upright and have a second person lift the handle (D) until the elliptical will roll on the wheels. Carefully move the elliptical to the desired location, and then lower it to the floor.

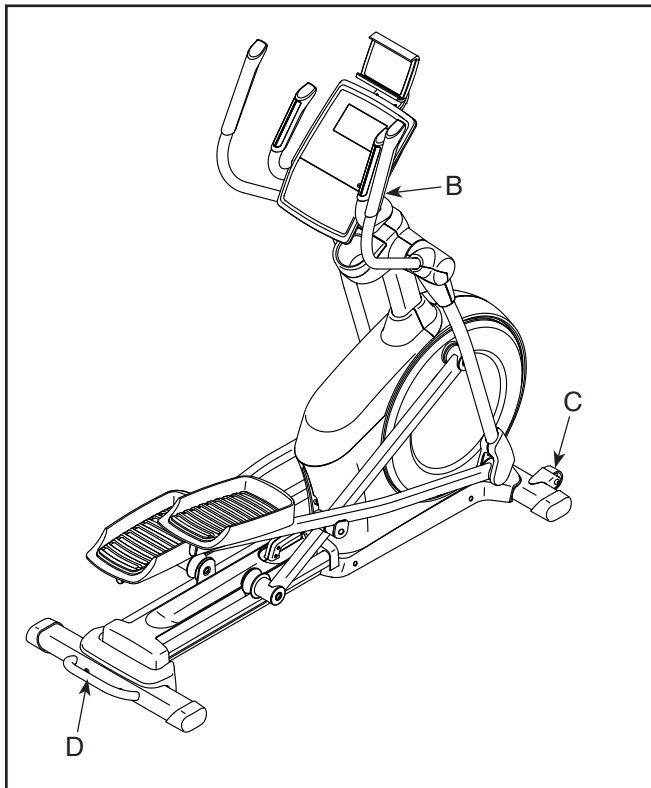

## HOW TO USE THE TABLET HOLDER

**IMPORTANT:** The tablet holder (G) is designed for use with most full-size tablets. Do not place any other electronic device or object in the tablet holder.

To insert a tablet into the tablet holder (G), set the bottom edge of the tablet in the tray. Then, pull the clip over the top edge of the tablet. **Make sure that the tablet is firmly secured in the tablet holder.** Rotate the tablet holder to the desired angle. Reverse these actions to remove the tablet from the tablet holder.

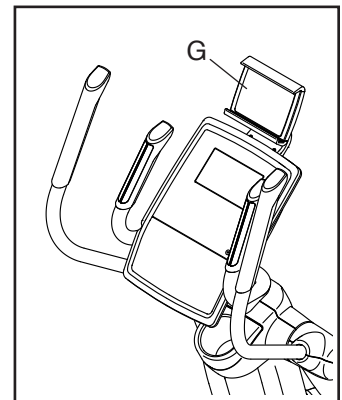

## HOW TO CHANGE THE INCLINE OF THE RAMP

To vary the motion of the pedals, you can change the incline of the ramp. To raise the ramp, simply pull the ramp handle (H) upward to the desired incline level.

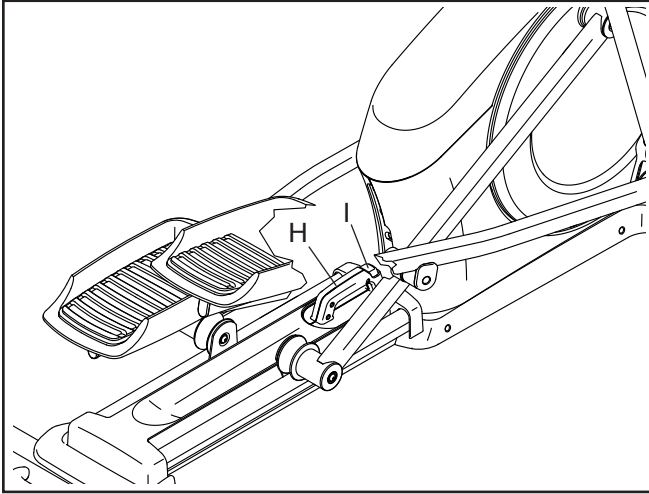

To lower the ramp, press the latch button (I), pull the ramp handle (H), and lower the ramp to the desired incline level. Then, release the latch button and engage the latch pin into one of the adjustment holes in the frame. **Make sure that the latch pin is firmly engaged in one of the adjustment holes in the frame.**

## HOW TO EXERCISE ON THE ELLIPTICAL

**See the drawing at the right.** To mount the elliptical, hold the handlebars (J) or the upper body arms (K) and step onto the pedal (L) that is in the lower position. Then, step onto the other pedal. Push the pedals until they begin to move with a continuous motion. **Note: The pedals can turn in either direction. It is recommended that you turn the pedals in the direction shown by the arrow; however, for variety, you can turn the pedals in the opposite direction.**

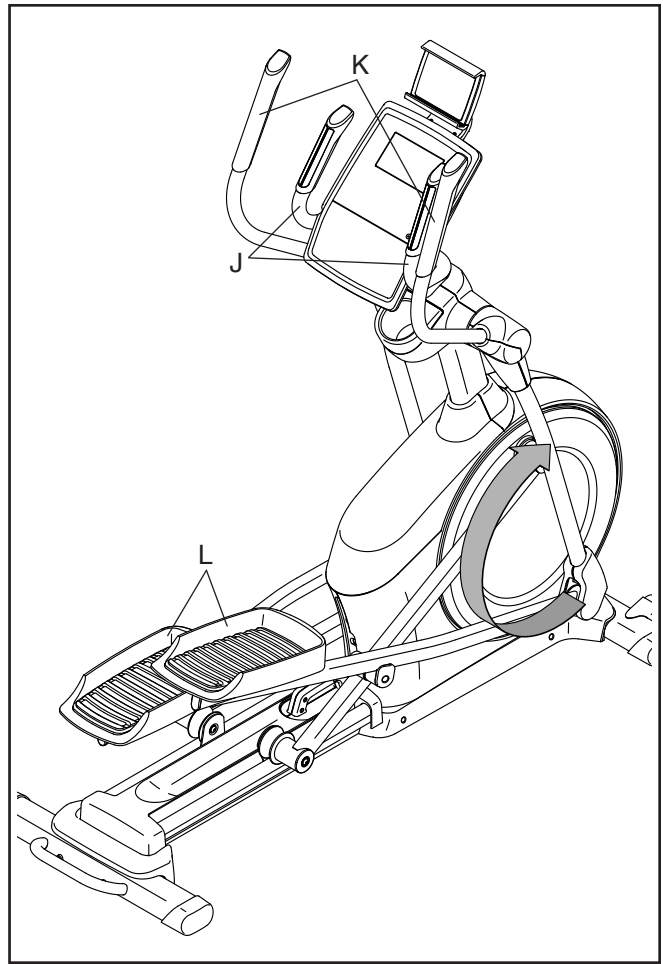

To dismount the elliptical, wait until the pedals (L) come to a complete stop. **Note: The elliptical does not have a free wheel; the pedals will continue to move until the flywheel stops.** When the pedals are stationary, step off the higher pedal first. Then, step off the lower pedal.

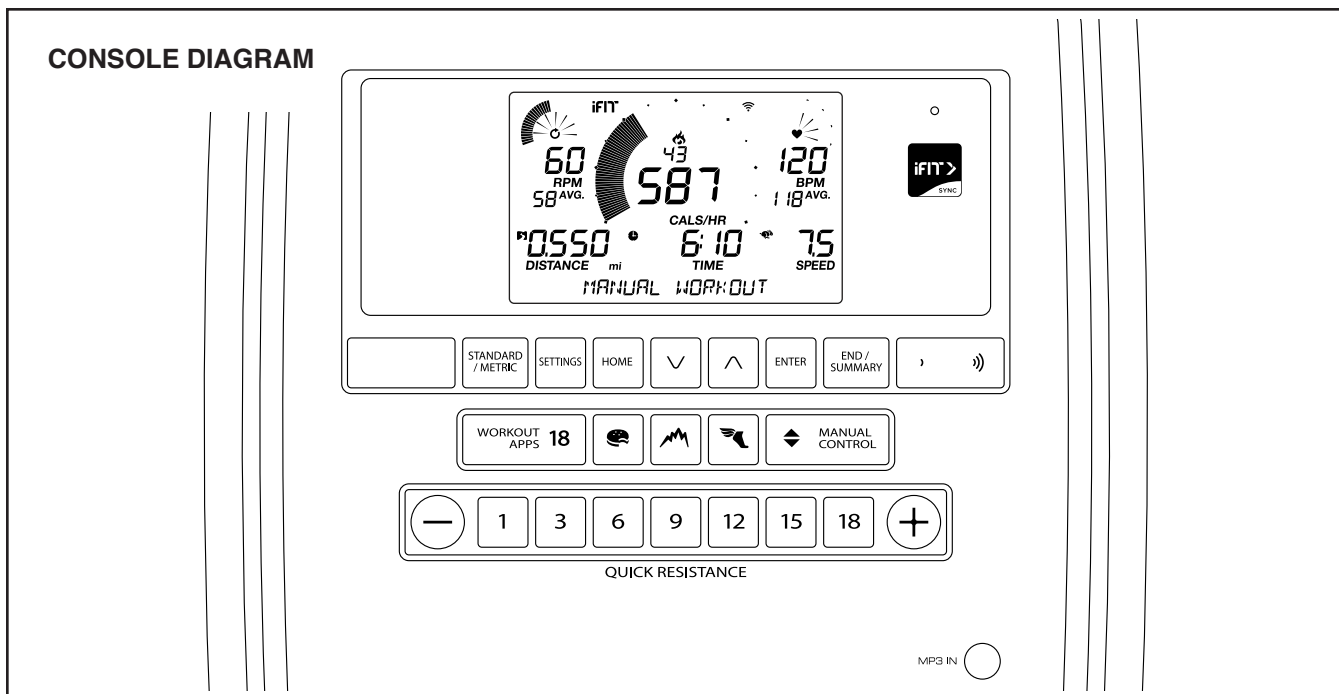

## FEATURES OF THE CONSOLE

The advanced console offers an array of features designed to make your workouts more effective and enjoyable.

When you use the manual mode of the console, you can change the resistance of the pedals with the touch of a button.

While you exercise, the console will display continuous exercise feedback. You can also measure your heart rate using the handgrip heart rate monitor or a compatible heart rate monitor. **See page 24 for information about purchasing an optional chest heart rate monitor.**

You can also connect your tablet to the console and use the iFit® Bluetooth Tablet app to record and track your workout information.

The console also offers a selection of onboard workouts. Each workout automatically changes the

resistance of the pedals as it guides you through an effective workout.

You can even connect your personal audio player to the console sound system and listen to your favorite music or audio books while you exercise.

**To use the manual mode**, see page 20. **To use an onboard workout**, see page 22. **To connect your tablet to the console**, see page 23. **To connect your heart rate monitor to the console**, see page 23. **To use the sound system**, see page 24. **To change console settings**, see page 24.

Note: If there is a sheet of plastic on the display, remove the plastic.

Note: The console can display speed and distance in either miles or kilometers. To change the unit of measurement, press the Standard/Metric button repeatedly. For simplicity, all instructions in this section refer to miles.

## HOW TO USE THE MANUAL MODE

1. **Begin pedaling or press any button on the console to turn on the console.**

When you turn on the console, the display will turn on. The console will then be ready for use.

2. **Select the manual mode.**

Press the Manual Control button to select the manual mode.

3. **Change the resistance of the pedals as desired.**

As you pedal, change the resistance of the pedals by pressing the Quick Resistance increase and decrease buttons or by pressing one of the numbered Quick Resistance buttons.

Note: After you press a button, it will take a moment for the pedals to reach the selected resistance level.

4. **Follow your progress with the displays.**

The display can show the following workout information:

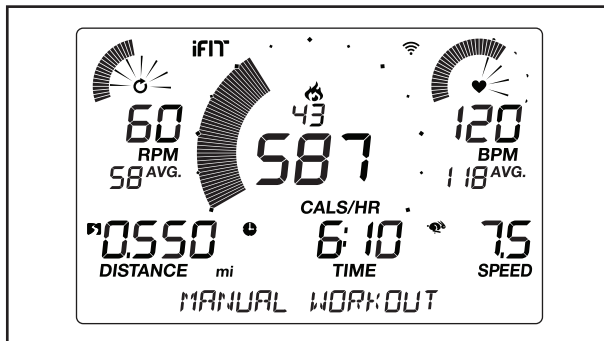

**Calories (flame icon)**—This display will show the approximate number of calories you have burned.

**Calories per Hour (Cals/Hr)**—This display will show the approximate number of calories you are burning per hour.

**Distance**—This display will show the distance that you have pedaled in miles (mi) or kilometers (km).

**Pulse (BPM)**—This display will show your heart rate in beats per minute (bpm) when you use the handgrip heart rate monitor or the optional chest heart rate monitor (see step 5).

**Pulse Average (BPM AVG)**—This display will show your average heart rate in beats per minute (bpm) when you use the handgrip heart rate monitor or the optional chest heart rate monitor (see step 5).

**Resistance**—This display will show the resistance level of the pedals for a few seconds each time the resistance level changes.

**RPM**—This display will show your pedaling speed in revolutions per minute (rpm).

**RPM Average (RPM AVG)**—This display will show your average pedaling speed in revolutions per minute (rpm).

**Speed**—This display will show your pedaling speed in miles per hour or kilometers per hour. To change the unit of measurement, press the Standard/Metric button repeatedly.

**Time**—When the manual mode is selected, this display will show the elapsed time. When an onboard workout is selected, this display will show the time remaining in the workout.

**Watts**—This display will show your approximate power output in watts.

**Average Watts (AVG.)**—This display will show your approximate average power output in watts for the workout.

### Scan Mode and Priority

**Mode**—The calories and watts displays will appear in an alternating cycle (scan mode).

To select either the calories display or the watts display for continuous display (priority mode), press the increase or decrease button next to the Enter button repeatedly until the desired display appears. To return to the scan mode, press the increase button repeatedly until the word SCAN appears.



Press the Home button to exit the workout and return to the main menu. If necessary, press the Home button again.

Press the End/Summary button to end the workout and view a workout summary. The workout summary will appear in the displays for several seconds.

Change the volume level of the console by pressing the volume increase and decrease buttons.

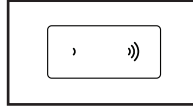

## 5. Measure your heart rate if desired.

You can measure your heart rate using either the handgrip heart rate monitor or an optional chest heart rate monitor (**see page 24 for information about the optional chest heart rate monitor**). Note: The console is compatible with BLUETOOTH® Smart heart rate monitors.

**Note: If you use both heart rate monitors at the same time, the chest heart rate monitor will have priority.**

**If there are sheets of plastic on the metal contacts (A) on the handgrip heart rate monitor, remove the plastic.** To measure your heart rate, hold the handgrip heart rate monitor with your palms resting against the contacts. **Avoid moving your hands or gripping the contacts tightly.**

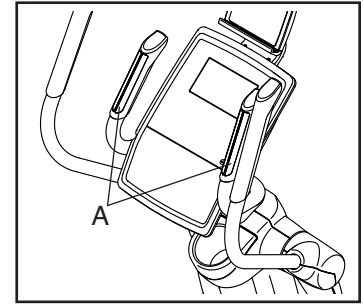

When your pulse is detected, your heart rate will appear in the display. **For the most accurate heart rate reading, hold the contacts for at least 15 seconds.**

## 6. When you are finished exercising, the console will turn off automatically.

If the pedals do not move for several seconds, a tone will sound, the console will pause, and the time will flash in the display. To resume your workout, simply resume pedaling.

If the pedals do not move for several minutes and the buttons are not pressed, the console will turn off and the display will be reset.

## HOW TO USE AN ONBOARD WORKOUT

### 1. Begin pedaling or press any button on the console to turn on the console.

When you turn on the console, the display will turn on. The console will then be ready for use.

### 2. Select an onboard workout.

To select an onboard workout, press the desired Workout Apps button repeatedly until the desired workout appears in the display.

When you select an onboard workout, the display will show the name of the workout and the duration of the workout or the number of calories to be burned.

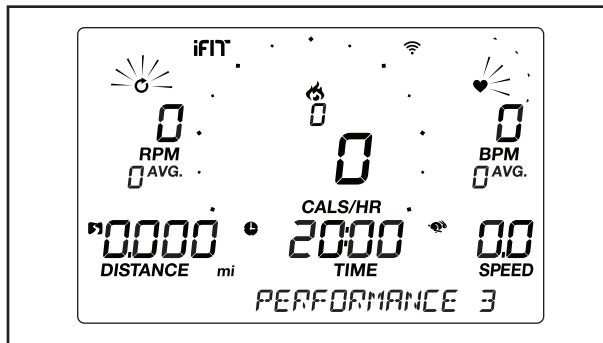

The the maximum speed and the maximum resistance level for the workout will also appear in the display.

### 3. Begin pedaling to start the workout.

Each workout is divided into one-minute segments. One resistance level and one target speed is programmed for each segment. Note: The same resistance level and/or target speed may be programmed for consecutive segments.

At the end of each segment of the workout, a series of tones will sound. If a different resistance

level and/or target speed is programmed for the next segment, the resistance level and/or target speed will appear in the display for a few seconds to alert you. The resistance of the pedals will then change.

As you exercise, keep your pedaling speed near the target speed for the current segment.

**IMPORTANT: The target speed is intended only to provide motivation. Your actual pedaling speed may be slower than the target speed. Make sure to pedal at a speed that is comfortable for you.**

If the resistance level for the current segment is too high or too low, you can manually override the setting by pressing the Quick Resistance buttons. **IMPORTANT: When the current segment of the workout ends, the pedals will automatically adjust to the resistance level programmed for the next segment.**

The workout will continue in this way until the last segment ends. To pause the workout at any time, stop pedaling. The time will flash in the display. To resume the workout, simply resume pedaling.

To end the workout, press the End/Summary button. A summary of the workout will appear in the displays for several seconds.

### 4. Follow your progress with the displays.

See step 4 on page 20.

### 5. Measure your heart rate if desired.

See step 5 on page 21.

### 6. When you are finished exercising, the console will turn off automatically.

See step 6 on page 21.

## HOW TO CONNECT YOUR TABLET TO THE CONSOLE

The console supports BLUETOOTH connections to tablets via the iFit Bluetooth Tablet app and to compatible heart rate monitors. Note: Other BLUETOOTH connections are not supported.

### 1. Download and install the iFit Bluetooth Tablet app on your tablet.

On your iOS® or Android™ tablet, open the App Store<sup>SM</sup> or the Google Play™ store, search for the free iFit Bluetooth Tablet app, and then install the app on your tablet. **Make sure that the BLUETOOTH option is enabled on your tablet.**

Then, open the iFit Bluetooth Tablet app and follow the instructions to set up an iFit account and customize settings.

### 2. Connect your heart rate monitor to the console if desired.

If you are connecting both your heart rate monitor and your tablet to the console, **you must connect your heart rate monitor before you connect your tablet.** See HOW TO CONNECT YOUR HEART RATE MONITOR TO THE CONSOLE at the right.

### 3. Connect your tablet to the console.

Press the iFit Sync button on the console; the console pairing number will appear in the display. Then, follow the instructions in the iFit Bluetooth Tablet app to connect your tablet to the console.

When a connection is established, the LED on the console will turn solid blue.

### 4. Record and track your workout information.

Follow the instructions in the iFit Bluetooth Tablet app to record and track your workout information.

### 5. Disconnect your tablet from the console if desired.

To disconnect your tablet from the console, first select the disconnect option in the iFit Bluetooth Tablet app. Then, press and hold the iFit Sync button on the console until the LED on the console turns solid green.

Note: All BLUETOOTH connections between the console and other devices (including any tablets, heart rate monitors, and so forth) will be disconnected.

## HOW TO CONNECT YOUR HEART RATE MONITOR TO THE CONSOLE

The console is compatible with all BLUETOOTH Smart heart rate monitors.

To connect your BLUETOOTH Smart heart rate monitor to the console, press the iFit Sync button on the console; the console pairing number will appear in the display. When a connection is established, the LED on the console will flash red twice.

Note: If there is more than one compatible heart rate monitor near the console, the console will connect to the heart rate monitor with the strongest signal.

To disconnect your heart rate monitor from the console, press and hold the iFit Sync button on the console until the LED on the console turns solid green.

Note: All BLUETOOTH connections between the console and other devices (including any tablets, heart rate monitors, and so forth) will be disconnected.

## HOW TO USE THE SOUND SYSTEM

To play music or audio books through the console sound system while you exercise, plug a 3.5 mm male to 3.5 mm male audio cable (not included) into the jack on the console and into a jack on your personal audio player; **make sure that the audio cable is fully plugged in. Note: To purchase an audio cable, see your local electronics store.**

Next, press the play button on your personal audio player. Adjust the volume level using the volume increase and decrease buttons on the console or the volume control on your personal audio player.

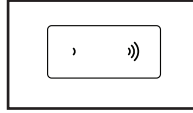

## THE OPTIONAL CHEST HEART RATE MONITOR

Whether your goal is to burn fat or to strengthen your cardiovascular system, the key to achieving the best results is to maintain the proper heart rate during your workouts. The optional chest heart rate monitor will enable you to continuously monitor your heart rate while you exercise, helping you to reach your personal fitness goals. **To purchase a chest heart rate monitor, please see the front cover of this manual.**

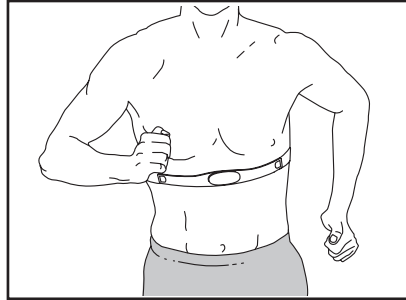

Note: The console is compatible with all BLUETOOTH Smart heart rate monitors.

## HOW TO CHANGE CONSOLE SETTINGS

### 1. Select the settings mode.

To select the settings mode, press the gear button. The settings information will appear in the display.

### 2. Navigate the settings mode.

While the settings mode is selected, the display will show several optional screens. Press the increase and decrease buttons near the Enter button repeatedly to select the desired optional screen.

The lower section of the display will show instructions for the selected screen. **Make sure to follow the instructions shown in the lower part of the display.**

### 3. Change settings as desired.

**Units**—The currently selected unit of measurement will appear in the display. To change the unit of measurement, press the Enter button repeatedly. To view distance in miles, select ENGLISH. To view distance in kilometers, select METRIC.

**Contrast Level**—The currently selected contrast level will appear in the display. Press the Quick Resistance increase and decrease buttons to adjust the contrast level.

**Usage Information**—The display will show the total number of hours that the elliptical has been used and the total distance (in miles or kilometers) that has been pedaled on the elliptical.

### 4. Exit the settings mode.

Press the gear button to exit the settings mode.



---

## FCC INFORMATION

This equipment has been tested and found to comply with the limits for a Class B digital device, pursuant to Part 15 of the FCC Rules. These limits are designed to provide reasonable protection against harmful interference in a residential installation. This equipment generates, uses, and can radiate radio frequency energy and, if not installed and used in accordance with the instructions, may cause harmful interference to radio communications. However, there is no guarantee that interference will not occur in a particular installation. If this equipment does cause harmful interference to radio or television reception, which can be determined by turning the equipment off and on, try to correct the interference by one or more of the following measures:

- Reorient or relocate the receiving antenna.
- Increase the separation between the equipment and the receiver.
- Connect the equipment into an outlet on a circuit different from that to which the receiver is connected.
- Consult the dealer or an experienced radio/TV technician for help.

**FCC CAUTION: To assure continued compliance, use only shielded interface cables when connecting to computer or peripheral devices. Changes or modifications not expressly approved by the party responsible for compliance could void the user's authority to operate this equipment.**

**IMPORTANT: To satisfy exposure compliance requirements, the antenna and transmitter in the console must be at least 8 in. (20 cm) from all persons and must not be near or connected to any other antenna or transmitter.**

**Note: The console contains FCC ID: OMCBMD1.**

# MAINTENANCE AND TROUBLESHOOTING

## MAINTENANCE

Regular maintenance is important for optimal performance and to reduce wear. Inspect and properly tighten all parts each time the elliptical is used. Replace any worn parts immediately.

To clean the elliptical, use a damp cloth and a small amount of mild soap. **IMPORTANT: To avoid damage to the console, keep liquids away from the console and keep the console out of direct sunlight.**

## CONSOLE TROUBLESHOOTING

If the console does not display your heart rate when you hold the handgrip heart rate monitor, or if the displayed heart rate appears to be too high or too low, see step 5 on page 21.

If lines appear in the console display, see step 3 on page 24 and adjust the contrast level of the display.

**If a replacement power adapter is needed, call the telephone number on the cover of this manual. IMPORTANT: To avoid damaging the console, use only a manufacturer-supplied regulated power adapter.**

## HOW TO ADJUST THE REED SWITCH

If the console does not display correct feedback, the reed switch should be adjusted. To adjust the reed switch, first **unplug the power adapter**.

Next, using a standard screwdriver, remove the left Disc (71).

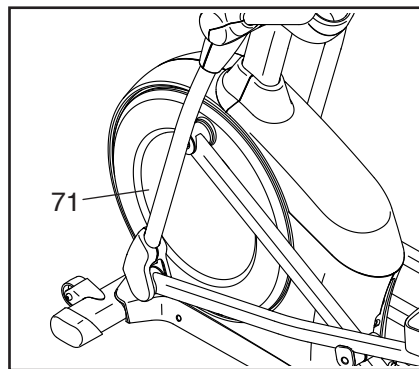

Note: For clarity, the left shield is shown removed in the drawing at the right.

Locate the Reed Switch (38). Turn the Pulley (19) until a Magnet (43) is aligned with the Reed Switch.

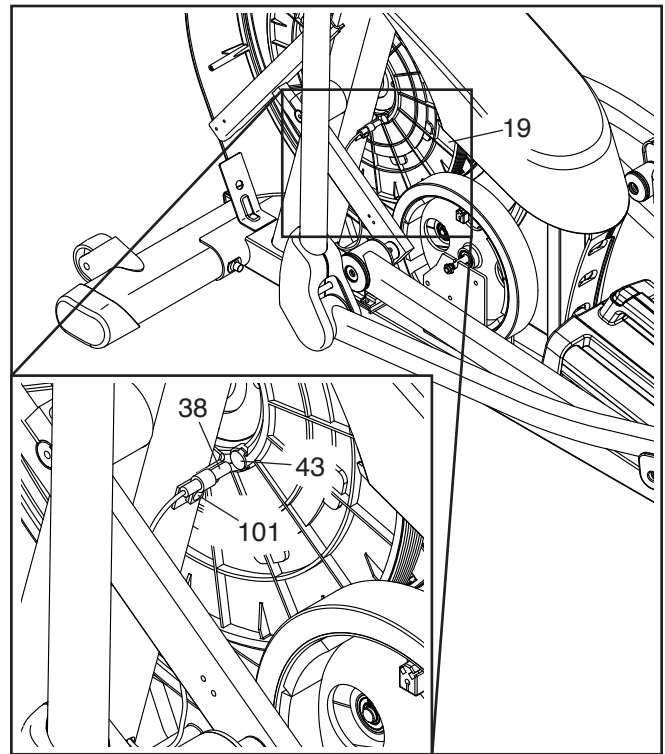

Next, slightly loosen the indicated M4 x 16mm Screw (101). Slide the Reed Switch (38) slightly closer to or away from the Magnet (43), and then retighten the Screw.

Then, plug in the power adapter and rock the Pulley (19) forward and backward just enough that the Magnet (43) passes the Reed Switch (38) repeatedly. Repeat these actions until the console displays correct feedback.

When the reed switch is correctly adjusted, reattach the left disc and plug in the power adapter.

## HOW TO ADJUST THE DRIVE BELT

If the pedals slip while you are pedaling, even while the resistance is adjusted to the highest level, the drive belt may need to be adjusted.

To adjust the drive belt, first **unplug the power adapter**.

Next, use a standard screwdriver to remove the Shield Cover (75) and the Shield Cover Cap (118).

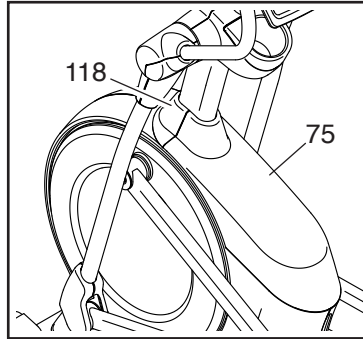

See assembly step 15 on page 14. Remove the Right Leg Outer and Inner Covers (69, 83).

See assembly step 12 on page 12. Remove the Right Pedal Arm (58) from the Right Upper Body Leg (60).

Next, remove the M8 x 16mm Screw (95) and the Axle Cover (53) from the right Crank Arm (20). Then, carefully remove the Right Roller Arm (59) and the Right Pedal Arm (58) from the elliptical.

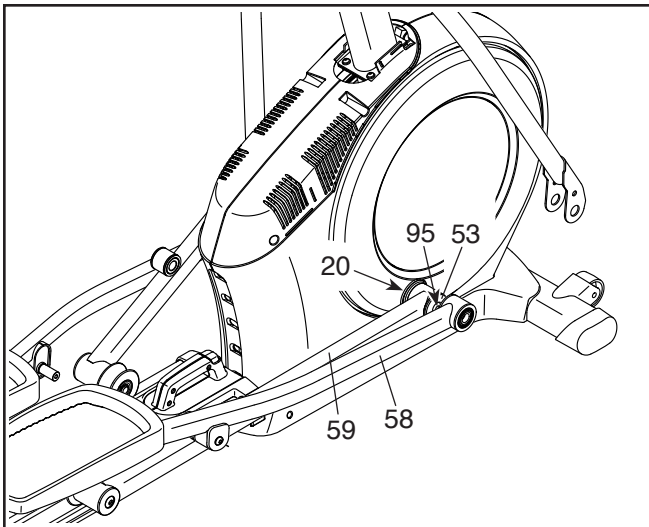

See **EXPLODED DRAWING C** on page 35. Identify the Left and Right Shields (73, 74). Remove the M4 x 19mm Tek Screws (5), the M4 x 19mm Screws (124), and the M4 x 48mm Screw (107) from the Left and Right Shields; **make sure to note the location of each size of Screw**. Then, remove the Right Shield.

Next, locate and loosen the Idler Screw (89). Tighten the Belt Adjustment Screw (91) until the Drive Belt (113) is tight. Then, retighten the Idler Screw.

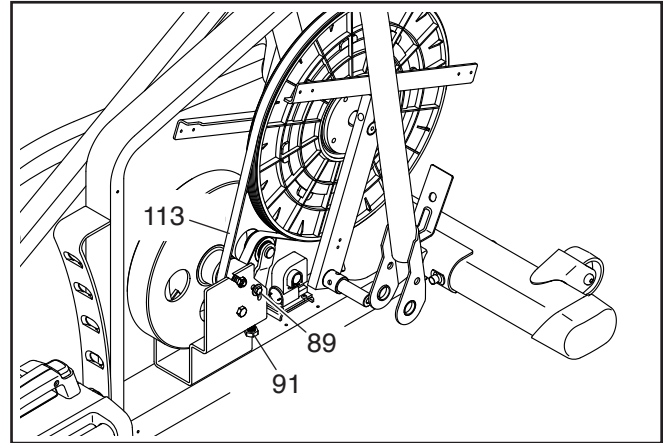

Reattach the parts that you removed. Then, plug in the power adapter.

# EXERCISE GUIDELINES

**⚠️ WARNING:** Before beginning this or any exercise program, consult your physician. This is especially important for persons over age 35 or persons with pre-existing health problems.

The heart rate monitor is not a medical device. Various factors may affect the accuracy of heart rate readings. The heart rate monitor is intended only as an exercise aid in determining heart rate trends in general.

These guidelines will help you to plan your exercise program. For detailed exercise information, obtain a reputable book or consult your physician. Remember, proper nutrition and adequate rest are essential for successful results.

## EXERCISE INTENSITY

Whether your goal is to burn fat or to strengthen your cardiovascular system, exercising at the proper intensity is the key to achieving results. You can use your heart rate as a guide to find the proper intensity level. The chart below shows recommended heart rates for fat burning and aerobic exercise.

165	155	145	140	130	125	115	♥♥
145	138	130	125	118	110	103	♥
125	120	115	110	105	95	90	♥
<hr/>							
20	30	40	50	60	70	80	

To find the proper intensity level, find your age at the bottom of the chart (ages are rounded off to the nearest ten years). The three numbers listed above your age define your “training zone.” The lowest number is the heart rate for fat burning, the middle number is the heart rate for maximum fat burning, and the highest number is the heart rate for aerobic exercise.

**Burning Fat**—To burn fat effectively, you must exercise at a low intensity level for a sustained period of time. During the first few minutes of exercise, your body uses carbohydrate calories for energy. Only after the first few minutes of exercise does your body begin to use stored fat calories for energy. If your goal is to burn fat, adjust the intensity of your exercise until your heart rate is near the lowest number in your training zone. For maximum fat burning, exercise with your heart rate near the middle number in your training zone.

**Aerobic Exercise**—If your goal is to strengthen your cardiovascular system, you must perform aerobic exercise, which is activity that requires large amounts of oxygen for prolonged periods of time. For aerobic exercise, adjust the intensity of your exercise until your heart rate is near the highest number in your training zone.

## WORKOUT GUIDELINES

**Warming Up**—Start with 5 to 10 minutes of stretching and light exercise. A warm-up increases your body temperature, heart rate, and circulation in preparation for exercise.

**Training Zone Exercise**—Exercise for 20 to 30 minutes with your heart rate in your training zone. (During the first few weeks of your exercise program, do not keep your heart rate in your training zone for longer than 20 minutes.) Breathe regularly and deeply as you exercise; never hold your breath.

**Cooling Down**—Finish with 5 to 10 minutes of stretching. Stretching increases the flexibility of your muscles and helps to prevent post-exercise problems.

## EXERCISE FREQUENCY

To maintain or improve your condition, complete three workouts each week, with at least one day of rest between workouts. After a few months of regular exercise, you may complete up to five workouts each week, if desired. Remember, the key to success is to make exercise a regular and enjoyable part of your everyday life.

## SUGGESTED STRETCHES

The correct form for several basic stretches is shown at the right. Move slowly as you stretch; never bounce.

### 1. Toe Touch Stretch

Stand with your knees bent slightly and slowly bend forward from your hips. Allow your back and shoulders to relax as you reach down toward your toes as far as possible. Hold for 15 counts, then relax. Repeat 3 times. Stretches: Hamstrings, back of knees and back.

### 2. Hamstring Stretch

Sit with one leg extended. Bring the sole of the opposite foot toward you and rest it against the inner thigh of your extended leg. Reach toward your toes as far as possible. Hold for 15 counts, then relax. Repeat 3 times for each leg. Stretches: Hamstrings, lower back and groin.

### 3. Calf/Achilles Stretch

With one leg in front of the other, reach forward and place your hands against a wall. Keep your back leg straight and your back foot flat on the floor. Bend your front leg, lean forward and move your hips toward the wall. Hold for 15 counts, then relax. Repeat 3 times for each leg. To cause further stretching of the achilles tendons, bend your back leg as well. Stretches: Calves, achilles tendons and ankles.

### 4. Quadriceps Stretch

With one hand against a wall for balance, reach back and grasp one foot with your other hand. Bring your heel as close to your buttocks as possible. Hold for 15 counts, then relax. Repeat 3 times for each leg. Stretches: Quadriceps and hip muscles.

### 5. Inner Thigh Stretch

Sit with the soles of your feet together and your knees outward. Pull your feet toward your groin area as far as possible. Hold for 15 counts, then relax. Repeat 3 times. Stretches: Quadriceps and hip muscles.

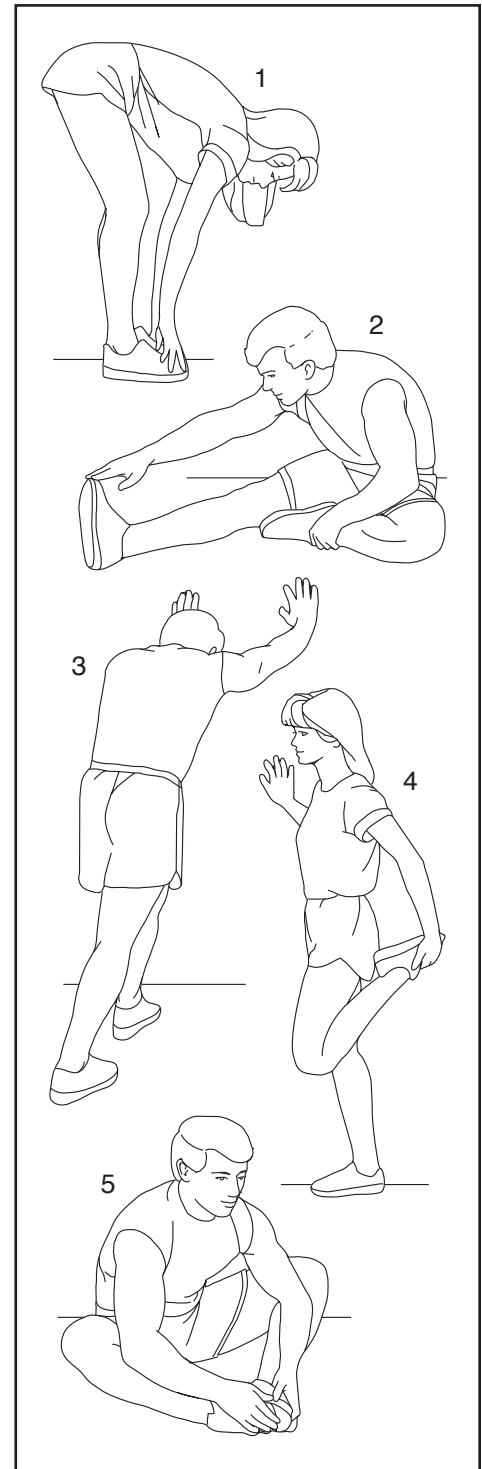

---

# NOTES

# PART LIST

Model No. GGEL65916.2 R0817A

Key No.	Qty.	Description	Key No.	Qty.	Description
1	1	Frame	51	2	Roller
2	1	Rear Stabilizer	52	2	Pedal Arm Cap
3	1	Ramp	53	2	Axle Cover
4	1	Upright	54	2	Pivot Spacer
5	9	M4 x 19mm Tek Screw	55	2	Retainer
6	1	Front Stabilizer	56	4	Roller Arm Bushing
7	1	Console	57	6	Large Arm Bearing
8	2	Roller Guide	58	1	Right Pedal Arm
9	1	M6 x 38mm Bolt	59	1	Right Roller Arm
10	1	Ramp Cover	60	1	Right Upper Body Leg
11	1	Left Latch Handle	61	1	Right Upper Body Arm
12	1	Right Latch Handle	62	2	Grip
13	1	Latch Button	63	2	Pulse Sensor/Wire
14	1	Latch Bracket	64	2	Pedal Arm Axle
15	1	Rear Stabilizer Cover	65	1	Right Arm Front Cover
16	2	Track	66	1	Right Arm Rear Cover
17	1	Latch Pin	67	1	Left Arm Front Cover
18	1	Crank	68	1	Left Arm Rear Cover
19	1	Pulley	69	1	Right Leg Outer Cover
20	2	Crank Arm	70	1	Left Leg Outer Cover
21	4	M4 x 10mm Screw	71	2	Disc
22	1	Idler	72	1	Left Leg Inner Cover
23	3	Bumper	73	1	Left Shield
24	1	Small Leveling Foot	74	1	Right Shield
25	1	Resistance Motor	75	1	Shield Cover
26	4	M10 Locknut	76	1	Left Pedal Arm Side Cap
27	2	M10 Washer	77	2	Clip
28	1	Eddy Mechanism	78	2	Key
29	1	Mechanism Axle	79	1	Front Console Cover
30	4	Stabilizer Cap	80	1	Rear Console Cover
31	2	M10 x 19mm Screw	81	1	Rear Upright Cover
32	2	M5 Washer	82	10	M8 x 13mm Screw
33	2	Leveling Foot	83	1	Right Leg Inner Cover
34	2	Wheel	84	1	Ramp Axle
35	1	Pivot Axle	85	1	Upright Grommet
36	2	Upright Bushing	86	2	M10 x 58mm Bolt
37	1	Accessory Tray	87	1	Right Pedal Arm Side Cap
38	1	Reed Switch/Wire	88	1	Idler Pivot Screw
39	1	Reed Switch Clamp	89	1	Idler Screw
40	2	Frame Bearing	90	2	M6 Washer
41	1	Small Snap Ring	91	1	Belt Adjustment Screw
42	1	Sleeve	92	4	M10 x 25mm Screw
43	2	Magnet	93	4	M4 x 12mm Screw
44	1	Left Pedal Arm	94	1	M4 Nut
45	1	Left Roller Arm	95	8	M8 x 16mm Screw
46	1	Left Upper Body Leg	96	4	M8 x 38mm Bolt
47	1	Left Upper Body Arm	97	4	M8 Washer
48	1	Ramp Spring	98	2	M8 x 18mm Washer
49	2	Pedal	99	1	Crank Spacer
50	6	Frame Bushing	100	4	Leg Bearing

Key No.	Qty.	Description	Key No.	Qty.	Description
101	38	M4 x 16mm Screw	118	1	Shield Cover Cap
102	4	M8 Locknut	119	1	Power Adapter
103	8	M6 x 12mm Screw	120	2	M8 x 20mm Screw
104	4	M10 x 122mm Screw	121	2	M10 Flange Nut
105	8	M10 Split Washer	122	1	Pin Spring
106	3	Cover Mount	123	2	Small Arm Bearing
107	1	M4 x 48mm Screw	124	2	M4 x 19mm Screw
108	2	M6 x 13mm Screw	125	2	Bearing Spacer
109	2	M10 x 60mm Bolt	126	1	M6 Nut
110	1	Upper Wire	127	2	M8 x 28mm Washer
111	1	Lower Wire	128	2	Pedal Insert
112	2	Roller Arm Cover	129	2	M4 Set Screw
113	1	Drive Belt	130	1	Tablet Holder
114	6	M4 x 42mm Screw	131	4	Tablet Holder Screw
115	1	M4 x 30mm Screw	*	–	Assembly Tool
116	2	Disc Ring	*	–	Grease Packet
117	1	Front Upright Cover	*	–	User's Manual

Note: Specifications are subject to change without notice. For information about ordering replacement parts, see the back cover of this manual. \*These parts are not illustrated.



# EXPLODED DRAWING A

Model No. GGEL65916.2 R0817A

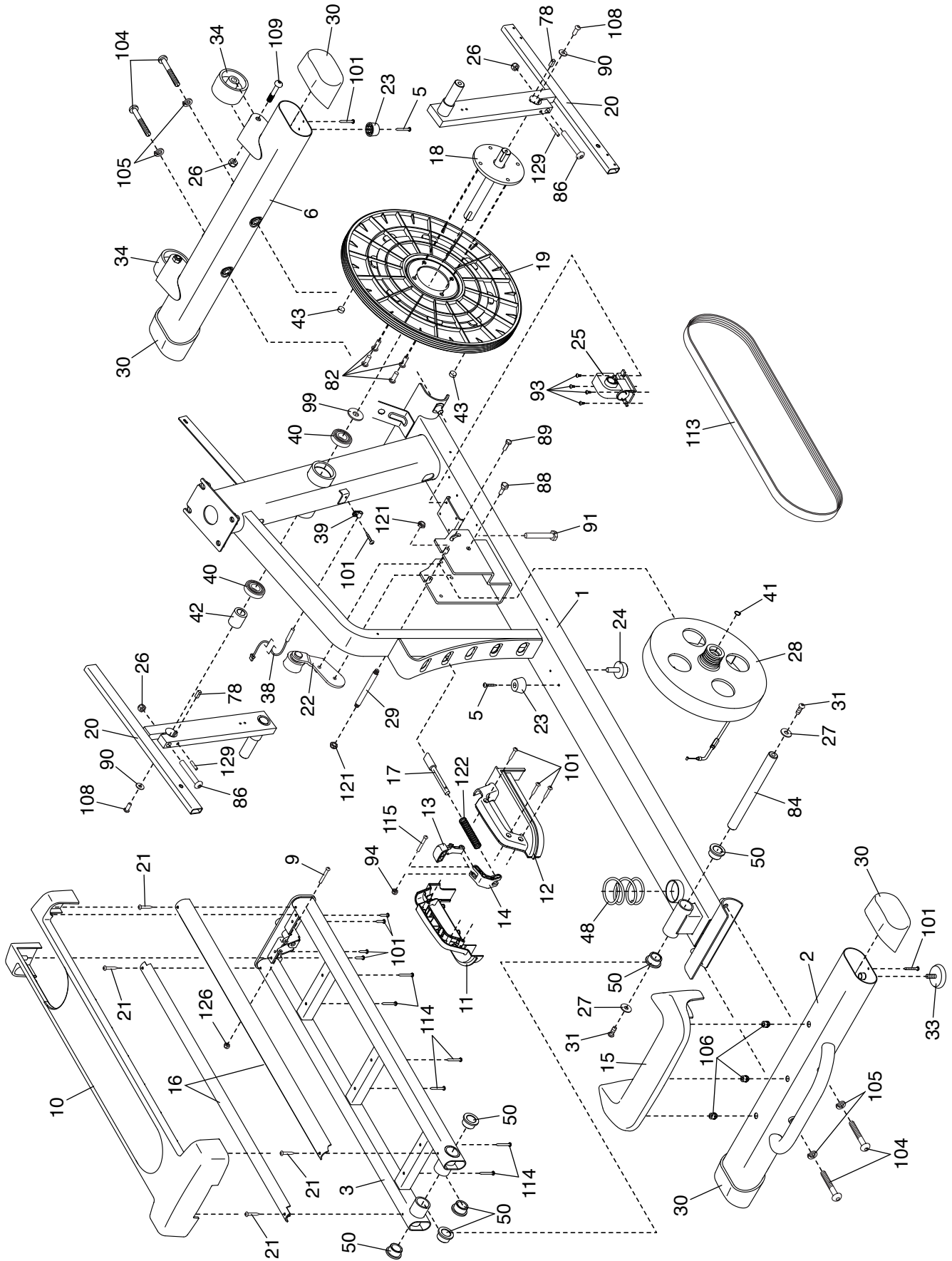

# EXPLODED DRAWING B

Model No. GGEL65916.2 R0817A

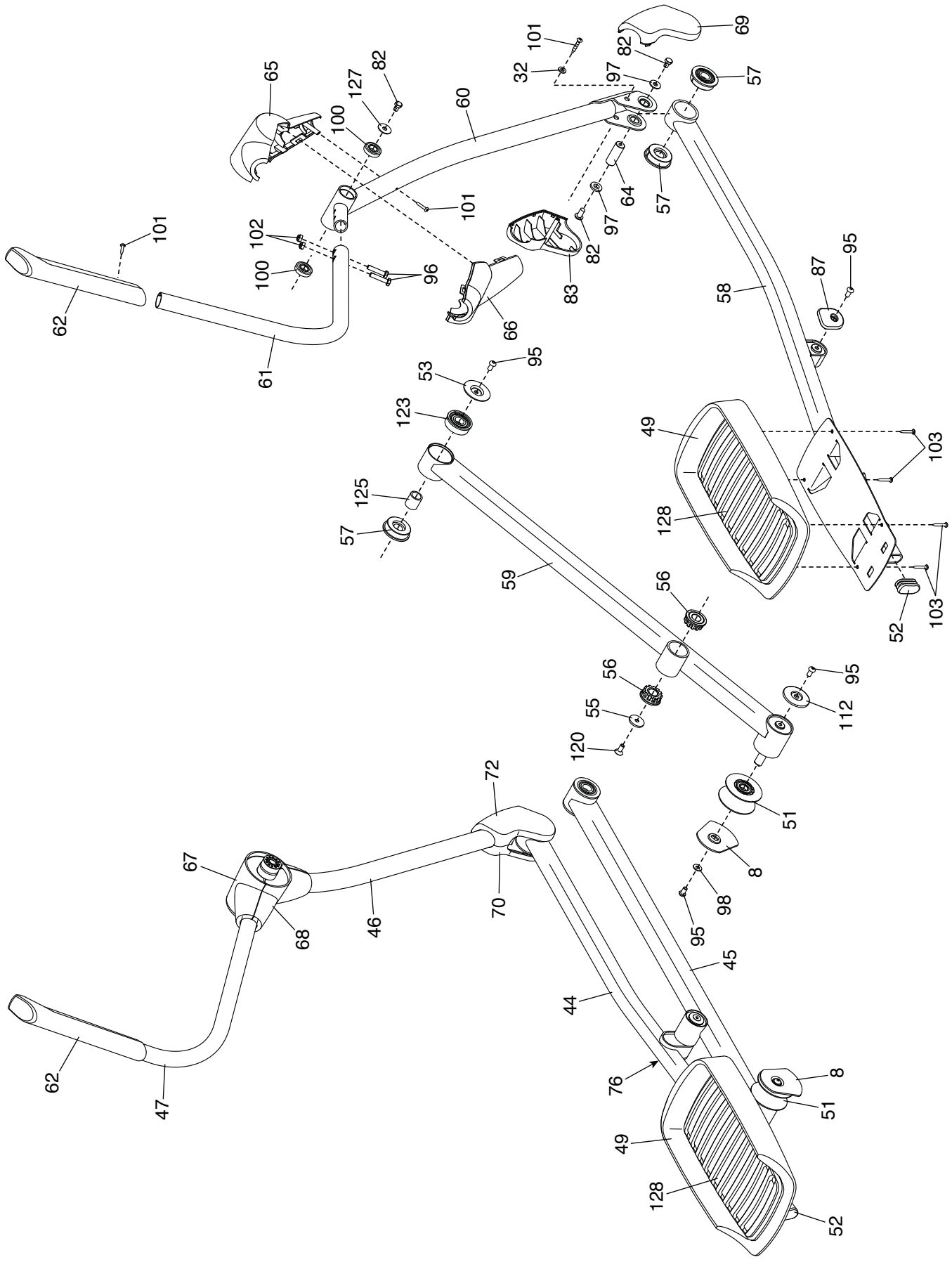

# EXPLODED DRAWING C

Model No. GGEL65916.2 R0817A

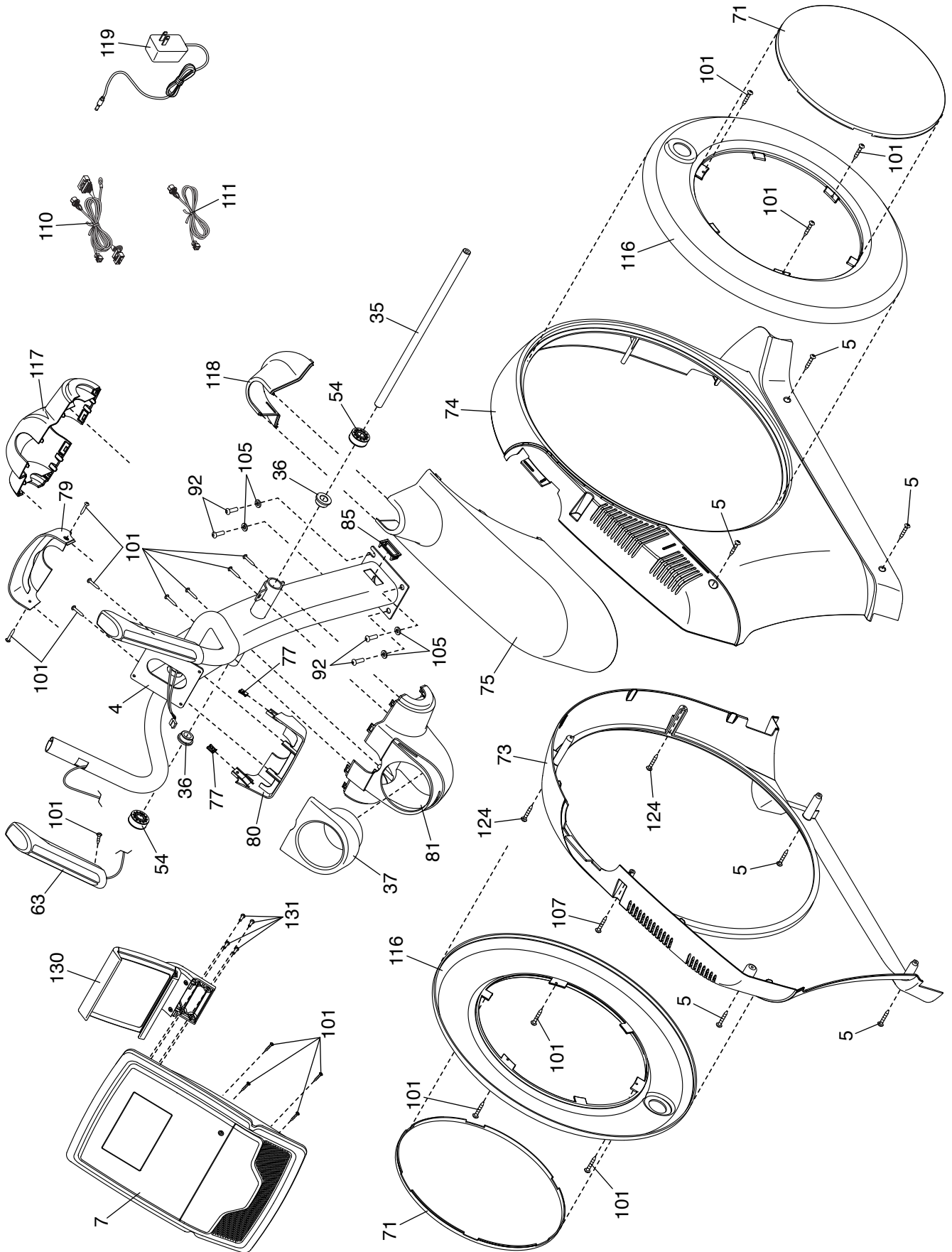

---

# ORDERING REPLACEMENT PARTS

To order replacement parts, please see the front cover of this manual. To help us assist you, be prepared to provide the following information when contacting us:

- the model number and serial number of the product (see the front cover of this manual)
- the name of the product (see the front cover of this manual)
- the key number and description of the replacement part(s) (see the PART LIST and the EXPLODED DRAWING near the end of this manual)

## LIMITED WARRANTY

**IMPORTANT: To protect your fitness equipment with an extended service plan, see page 4.**

ICON Health & Fitness, Inc. (ICON) warrants this product to be free from defects in workmanship and material, under normal use and service conditions. The frame is warranted for five (5) years from the date of purchase. Parts and labor are warranted for one (1) year from the date of purchase.

This warranty extends only to the original purchaser (customer) and is not transferrable. ICON's obligation under this warranty is limited to repairing or replacing, at ICON's option, the product through one of its authorized service providers. All repairs for which warranty claims are made must be preauthorized by ICON. If replacement parts are shipped while the product is under warranty, the customer will be responsible for a minimal handling charge. For in-home service, the customer may be responsible for a minimal trip charge. This warranty does not extend to freight damage to the product. This warranty will automatically be voided by the following conditions: (1) if the product is used as a store display model, (2) if the product is purchased or transported outside the USA, (3) if all instructions and warnings in this manual are not followed, (4) if the product is abused or improperly or abnormally used, or (5) if the product is used for commercial or rental purposes. No other warranty beyond that specifically set forth above is authorized by ICON.

ICON is not responsible or liable for the following damages: (1) indirect, special, or consequential damages arising out of or in connection with the use or performance of the product; (2) damages with respect to any economic loss, loss of property, loss of revenues or profits, loss of enjoyment or use, or costs of removal or installation; or (3) other consequential damages of any kind. Some states do not allow the exclusion or limitation of incidental or consequential damages. Accordingly, the above limitation may not apply to the customer.

The warranty extended hereunder is in lieu of any and all other warranties, and any implied warranties of merchantability or fitness for a particular purpose are limited in their scope and duration to the terms set forth herein. Some states do not allow limitations on how long an implied warranty lasts. Accordingly, the above limitation may not apply to the customer. This warranty provides specific legal rights; the customer may have other rights that vary from state to state.

For warranty service, please call the telephone number on the front cover of this manual. Please be prepared to provide the model number and serial number of the product (see the front cover of this manual).

**ICON Health & Fitness, Inc., 1500 S. 1000 W., Logan, UT 84321-9813**