

Owners Manual

Logwood 1269E

CONFORMS TO
UL 1482 (R2015)
&
CERTIFIED TO
CAN/ULC S627

"U.S. ENVIRONMENTAL PROTECTION AGENCY Certified to comply with 2015 particulate emission standards for single burn rate heaters. Not approved for sale after May 15, 2020. This single burn rate wood heater is not approved for use with a flue damper."

WASHINGTON STATE APPROVED
DO NOT USE THIS HEATER IN A MOBILE HOME
SAVE THESE INSTRUCTIONS.

THIS MANUAL WILL HELP YOU TO OBTAIN EFFICIENT, DEPENDABLE SERVICE FROM THE HEATER, AND ENABLE YOU TO ORDER REPAIR PARTS CORRECTLY. KEEP IN A SAFE PLACE FOR FUTURE REFERENCE.

French version is available for download from the United States Stove Company website: <http://www.usstove.com>/La version française est disponible pour téléchargement à partir du site United States Stove Company: <http://www.usstove.com/>

For use with Solid Fuel, Conforms to UL 1482
(R2015) and CAN/ULC-S627

CAUTION!

Please read this entire manual before you install or use your new room heater. **Failure to follow instructions may result in property damage, bodily injury, or even death.**
Improper Installation Could Void Your Warranty!

SAFETY NOTICE:

If this heater is not properly installed, a house fire may result. For your safety, follow the installation instructions. Never use make-shift compromises during the installation of this heater. Contact local building or fire officials about permits, restrictions and installation requirements in your area.

ALL RIGHTS RESERVED

PATENT
PENDING

ALL RIGHTS RESERVED

UNITED STATES STOVE COMPANY

227 Industrial Park Road
P.O. Box 151
South Pittsburg, TN 37380
(800) 750-2723



Intertek

852430D-4402F

CONGRATULATIONS!

You've purchased a heater from North America's oldest manufacturer of wood burning products.

By heating with wood you're helping to CONSERVE ENERGY!

Wood is our only Renewable Energy Resource. Please do your part to preserve our wood supply. Plant at least one tree each year. Future generations will thank you.

The instructions pertaining to the installation of your wood stove comply with UL & ULC standards.

Combustible:	Wood
Colors:	Flat Black
Flue Pipe Diameter:	6" (15.3cm)
Flue Pipe Type: (Standard Single Wall or Double Wall):	Black or Blued Steel 2100°F (650°C)
Minimum Chimney Height:	12' (3.7m)
Maximum Log Length:	22" (559mm)
Electrical:	None
Dimensions	
Overall (Depth x Width x Height):	33" x 18.5" x 23" (838mmX470mmX854mm)
Combustion Chamber: Width x Depth:	19" x 9" (482mmX229mm)
Volume: Cubic Feet:	1.2 cubic feet
Door Opening:	7.5 x 10.2 (191mmX259mm)
Pyroceramic Glass Door : (Viewing) Width x Height:	N/A
Weight (lbs):	140 lbs



This manual describes the installation and operation of the United States Stove Company Model 1269E woodheater. This heater meets the 2015 U.S. Environmental Protection Agency's crib wood emission limits for woodheaters sold after May 15, 2015. Under specific EPA test conditions burning Douglas Fir dimensional lumber this heater has been shown to deliver heat at a rate of 24,433 Btu/hr. This heater achieved a particulate emissions rate of 4.2 g/hr when tested to method ASTM E2780-10 single Burn Rate Appendix (*and an efficiency of 67.9 %.)

This wood heater has a manufacturer-set minimum low burn rate that must not be altered. It is against federal regulations to alter this setting or otherwise operate this wood heater in a manner inconsistent with operating instructions in this manual.

The operation of this wood heater in a manner inconsistent with the owner's manual will void your warranty and is also against federal regulations.

This heater is designed to burn natural wood only. Higher efficiencies and lower emissions generally result when burning air dried seasoned hardwoods, as compared to softwoods or to green or freshly cut hardwoods. Burning the following materials may result in release of toxic fumes or render the heater ineffective and cause smoke.

This wood heater needs periodic inspection and repair for proper operation. It is against federal regulations to operate this wood heater in a manner inconsistent with operating instructions in this manual.

Note: Register your product on line at www.usstove.com. See "Limited Warranty" section for specific warranty information for your new purchase. Save your receipt with your records for any claims.

DO NOT BURN:

1. Residential or commercial garbage;
2. Lawn clippings or yard waste;
3. Materials containing rubber, including tires;
4. Materials containing plastic;
5. Waste petroleum products, paints or paint thinners, or asphalt products;
6. Materials containing asbestos;
7. Construction or demolition debris;
8. Paper products, cardboard, plywood, or particleboard. The prohibition against burning these materials does not prohibit the use of fire starters made from paper, cardboard, saw dust, wax and similar substances for the purpose of starting a fire in unaffected wood heater.
9. Railroad ties or pressure-treated wood;
10. Manure or animal remains;
11. Salt water driftwood or other previously salt water saturated materials;
12. Unseasoned wood;
13. Any materials that are not included in the warranty and owner's manual for the subject wood heater; or
14. Any materials that were not included in the certification tests for the subject wood heater.

Tools and Materials Needed

TOOLS

- Pencil
- 6 Foot Folding Ruler or Tape Measure
- Tin Snips
- Drill, Hand or Electric
- Drill Bit 1/8" Dia. (For Sheet Metal Screws)
- Adjustable Wrench
- Screw Driver (Blade-Type)
- Gloves
- Safety Glasses

MATERIALS

- 6" Elbow, Collar and Thimble; As Required (24 gauge min.)
- 1/2" Sheet Metal Screws (No. 10A x 1/2")
- 6" Diameter, 24 gauge, black or blued steel flue connector pipe
- Floor Protector Material (R value = 2.06); Size and Installation as specified in this manual
- Furnace Cement (Manufacturer Recommends: Rutland Black Code 78 or Equivalent)
- Optional; 6" Barometric Draft Regulator (DR-6)

HEATER DIMENSIONS
FIG. 1

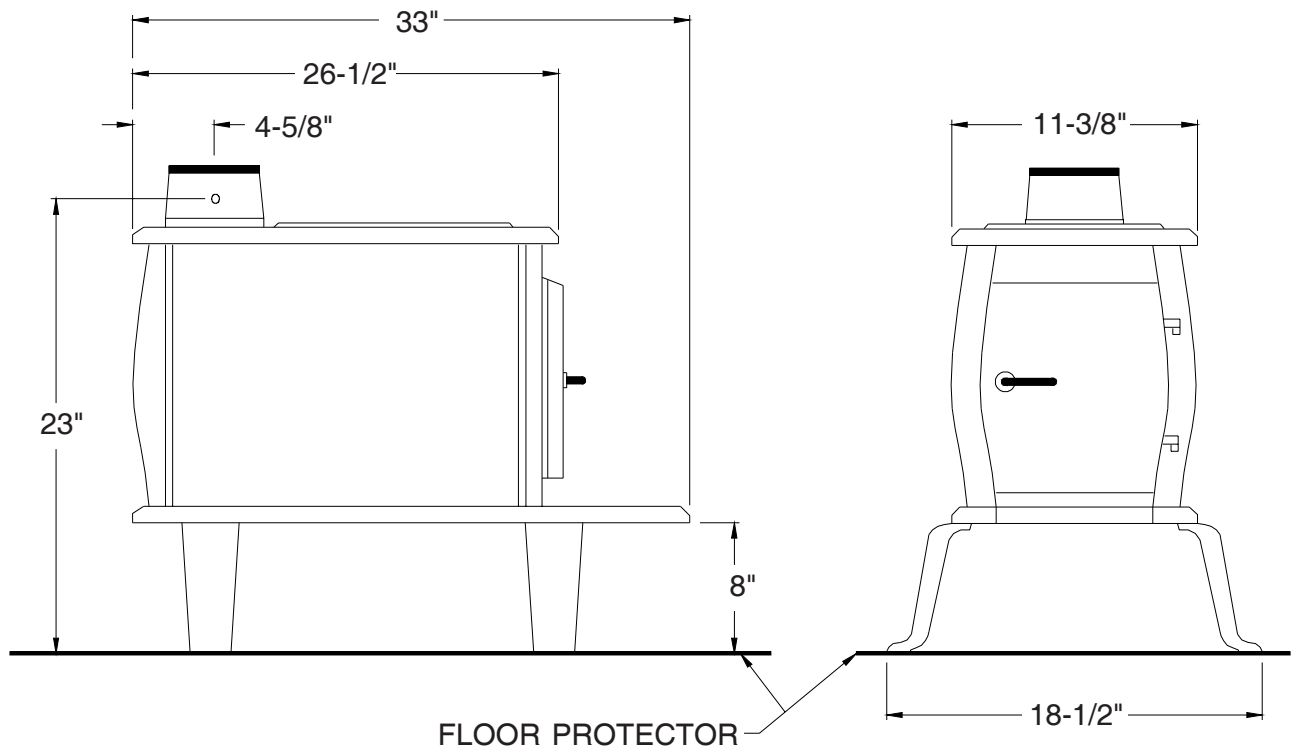

Operational Tips For The Best Performance Of Your Heater

BUILDING A FIRE

The top down method of fire building is recommended for this appliance. Place the largest pieces of wood on the bottom, laid in parallel and close together. Smaller pieces are placed in a second layer, crossways to the first. A third layer of still smaller pieces is laid crossways to the second, this time with some spaces between. Then a fourth layer of loose, small kindling and twisted newspaper sheets tops off the pile.

VISIBLE SMOKE

Visible smoke is basically unburned fuel and moisture leaving your stove. The amount of visible smoke being produced can be an effective method of determining how efficiently the combustion process is taking place at the given settings. Learn to adjust the air settings of your specific unit to produce the smallest amount of visible smoke. Remember that wood that has not been seasoned properly and has a high wood moisture content will produce excess visible smoke and burn poorly.

ASH REMOVAL AND DISPOSAL

Whenever ashes get 3 to 4 inches deep in your firebox or ash pan, and when the fire has burned down and cooled, remove excess ashes. Leave an ash bed approximately 1 inch deep on the firebox bottom to help maintain a hot charcoal bed.

Ashes should be placed in a metal container with a tight-fitting lid. The closed container of ashes should be placed on a noncombustible floor or on the ground, away from all combustible materials, pending final disposal. The ashes should be retained in the closed container until all cinders have thoroughly cooled.

AIR TUBES

The air tubes assembled in this unit are designed to provide an accurate mix of secondary air to insure the highest efficiency. Any damage or deterioration of these tubes may reduce the efficiency of combustion. The air tubes are held in position by either screws or snap pins. Locate these to either side of the tube and remove to allow the tube to be removed and replaced.

OVER FIRING

Attempts to achieve heat output rates that exceed heater design specifications can result in permanent damage to the heater and to the catalytic combustor if so equipped.

IMPORTANCE OF PROPER DRAFT

Draft is the force which moves air from the appliance up through the chimney. The amount of draft in your chimney depends on the length of the chimney, local geography, nearby obstructions and other factors. Too much draft may cause excessive temperatures in the appliance and may damage the catalytic combustor (if equipped). Inadequate draft may cause backpuffing into the room and 'plugging' of the chimney or the catalyst (if equipped). Inadequate draft will cause the appliance to leak smoke into the room through appliance and chimney connector joints. An uncontrollable burn or excessive temperature indicates excessive draft.

CHIMNEY

Take into account the chimney's location to insure it is not too close to neighbors or in a valley which may cause unhealthy or nuisance conditions.

EFFICIENCY

Efficiencies can be based on either the lower heating value (LHV) or the higher heating value (HHV) of the fuel. The lower heating value is when water leaves the combustion process as a vapor, in the case of woodstoves the moisture in the wood being burned leaves the stove as a vapor. The higher heating value is when water leaves the combustion process completely condensed. In the case of woodstoves this would assume the exhaust gases are room temperature when leaving the system, and therefore calculations using this heating value consider the heat going up the chimney as lost energy. Therefore, efficiency calculated using the lower heating value of wood will be higher than efficiency calculated using the higher heating value. In the United States all woodstove efficiencies should be calculated using the higher heating value.

As an operator of a wood heater the best way to achieve optimum efficiencies is to learn the burn characteristic of your appliance and burn well-seasoned wood. A good rule of thumb is that your heater is not producing or producing very little visible smoke it is burning efficiently. Also remember that higher burn rates are not always the best heating burn rates; after a good fire is established a lower burn rate may be a better option for efficient heating. A lower burn rate slows the flow of usable heat out of the home through the chimney, and it also consumes less wood.

SMOKE AND CO MONITORS

Burning wood naturally produces smoke and carbon monoxide (CO) emissions. CO is a poisonous gas when exposed to elevated concentrations for extended periods of time. While the modern combustion systems in heaters drastically reduce the amount of CO emitted out the chimney, exposure to the gases in closed or confined areas can be dangerous. Also make sure your stove gaskets and chimney joints are in good working order and sealing properly to ensure unintended exposure. It is recommended that you use both smoke and CO monitors in areas expected to or having the potential to generate CO.

OPERATIONAL TIPS FOR GOOD, EFFICIENT, AND CLEAN COMBUSTION

- Use smaller pieces of wood during start-up and a high burn rate to increase the stove temperature
- Be considerate of the environment and only burn dry wood
- Burn small, intense fires instead of large, slow burning fires when possible
- Learn your appliance's operating characteristics to obtain optimum performance
- Burning unseasoned wet wood only hurts your stove's efficiency and leads to accelerated creosote buildup in your chimney

WOOD SELECTION TIPS

Dead wood lying on the forest floor should be considered wet, and requires full seasoning time. Standing dead wood can usually be considered to be about 2/3 seasoned. Splitting and stacking wood before it is stored accelerates drying time. Storing wood on an elevated surface from the ground and under a cover or covered area from rain or snow also accelerates drying time. A good indicator if wood is ready to burn is to check the piece ends. If there are cracks radiating in all directions from the center then the wood should be dry enough to burn. If your wood sizzles in the fire, even though the surface is dry, it may not be fully cured, and should be seasoned longer.

Safety Rules

SAFETY NOTICE: If this heater is not properly installed, a house fire may result. For your safety, follow the installation directions. Contact local building or fire officials about restrictions and installation inspection requirements in your area.

READ THESE RULES AND THE INSTRUCTIONS CAREFULLY:

1. Check with local codes. The installation must comply with their rulings. Observe closely the clearances to combustibles.
2. Do not install this heater in a mobile home or trailer.
3. Always connect this heater to a chimney and vent to the outside. Never vent to another room or inside a building. **DO NOT CONNECT THIS UNIT TO A CHIMNEY FLUE SERVING ANOTHER APPLIANCE.**
4. Do not connect a wood burning heater to a Type B gas vent. This is not safe and is prohibited by the National Fire Protection Association Code. This heater requires approved masonry or UL, ULC Listed Residential Type and Building Heating Appliance Chimney. Use a 6" diameter chimney, or larger, that is high enough to give a good draft.
5. Be sure that your chimney is safely constructed and in good repair. Have the chimney inspected by the Fire Department or a qualified inspector. Your insurance company may be able to recommend a qualified inspector.
6. Inspect chimney connector and chimney twice monthly during the heating season for any deposit of creosote or soot which must be removed (see Chimney Maintenance).
7. Provide air for combustion from outside the house into the room where the heater is located. If the intake is not in the same room, air must have free access in to the room.
8. To prevent injury, do not allow anyone to use this heater who is unfamiliar with the correct operation of the heater.
9. For further information on using your heater safely, obtain a copy of the National Fire Protection Association (NFPA) publication "Using Coal and Wood Stoves Safely" NFPA No. HS-10-1978. The address of the NFPA is Batterymarch Park, MA 02269.
- For more information on a Canadian Installation, obtain a copy of CAN/CSA - B365 - M91 Installation Code for Solid-Fuel-Burning Appliances and Equipment.
10. Disposal of Ashes - Ashes should be placed in a metal container with a tight fitting lid. The closed container of ashes should be placed on a non-combustible floor or on the ground, well away from all combustible materials, pending final disposal. If the ashes are disposed of by burial in soil or otherwise locally dispersed, they should be retained in the closed container until all cinders have thoroughly cooled.
11. CAUTION - The special paints used on your heater may give off some smoke while they are curing during the first few fires. Build small fires at first. Children and people/animals with lung problems should take caution during the curing process.
12. CARING FOR PAINTED PARTS - This heater has a painted jacket which is durable but it will not stand rough handling or abuse. When installing your heater, use care in handling. Clean with soap and warm water when heater is not hot. DO NOT use any acids or scouring soap, as these wear and dull the finish. PAINT DISCOLORATION WILL OCCUR IF THE HEATER IS OVERFIRED. FOLLOW OPERATING INSTRUCTIONS CAREFULLY.
13. All persons, especially children, should be alerted to hazards from high surface temperatures and kept away while in operation. Small children should not be left unsupervised when in the room with the heater.
14. Keep the area adjacent to the heater free from all combustible materials, gasoline, and other flammable vapors.
15. This heater should not be used as a primary source of heat.

CAUTION! Do not touch the heater until it has cooled.

NOTE:

FOR YOUR SAFETY, WE RECOMMEND INSTALLING SMOKE DETECTORS IN YOUR HOME IF NOT ALREADY INSTALLED.

ASSEMBLY INSTRUCTIONS

NOTICE: United States Stove Company grants no warranty, stated or implied, for the installation or maintenance of your wood stove and assumes no responsibility of any incidental or consequential damages.

REQUIRED TOOLS

- Safety Glasses
- Hearth Gloves
- Pencil
- 6' Folding Ruler or Tape Measure
- Tin Snips
- Drill
- 1/8" dia. Drill Bit
- Adjustable Wrench
- (Sheet Metal Screws)
- #2 philips screw driver

REQUIRED MATERIALS

Note: the following items are not included with your stove

Flooring protector as specified

Chimney Connector

1/2" Sheet Metal Screws

Chimney

Furnace Cement

CAUTION: STOVE IS HEAVY. MAKE SURE YOU HAVE ADEQUATE HELP AND USE PROPER LIFTING TECHNIQUES WHENEVER MOVING STOVE.

1. Uncrate the stove and remove packing materials and protective poly bag. (save cardboard box for further assembly.)
2. Remove parts from inside of stove. Parts include: one feed door, four legs, hardware pack, flue collar, hearth plate, and bottom air channel.
3. Place flattened carton on floor and carefully turn stove over onto carton.
4. Attach bottom air channel with four (4) 1/4-20 X 3/8" screw, and four (4) washers.

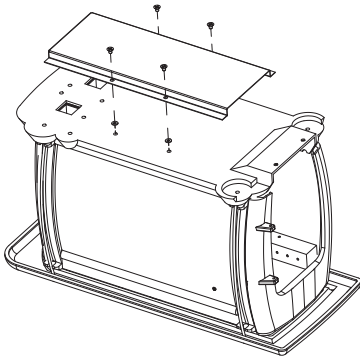

5. Attach hearth to bottom of stove with two (2) 1/4-20 x 1-3/16 screws, two (2) washers, and two (2) 1/4-20 jam nuts.

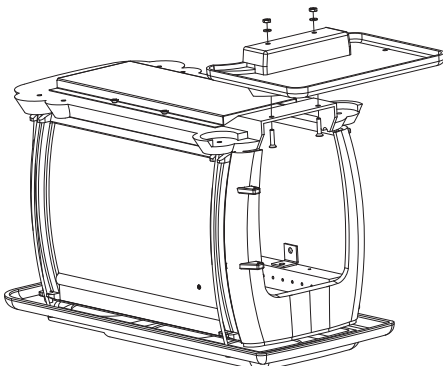

6. Attach the front legs to hearth with two (2) 1/4-20 x 1-3/4 screws, two (2) flat washers, and two (2) 1/4-20 jam nuts.
7. Attach the rear legs to base of stove with two (2) 1/4-20 x 1-3/4 screws, two (2) flat washers, and two (2) 1/4-20 jam nuts.

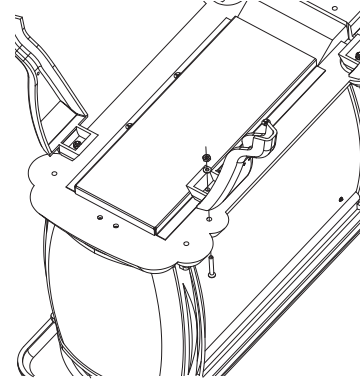

8. Carefully lift stove upright and place in desired location (see following instructions for properly locating stove.)

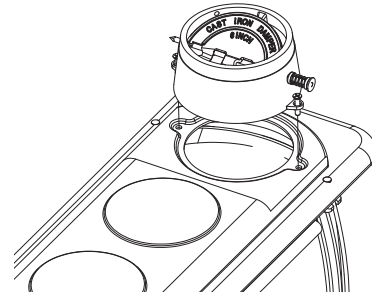

9. Lower feed door into position while aligning hinge pins.

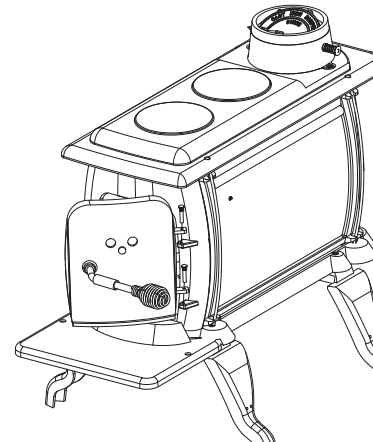

KEY	PART NO.	DESCRIPTION	QTY.
1	83658	1/4-20 X 1-3/16 Flathead Phillips Screw	4
2	83563	1/4-20 X 3/4 Flt Hd Ph Mach	4
3	83659	1/4-20 X 1-3/4 Flt Hd Ph Screw	4
4	83336	1/4-20 Jam Nut	10
5	83278	7/32 Id X 1/2 Od X 3/64 Fl W	10

Installation

MINIMUM CLEARANCE
TO COMBUSTIBLE WALLS
US, CANADA

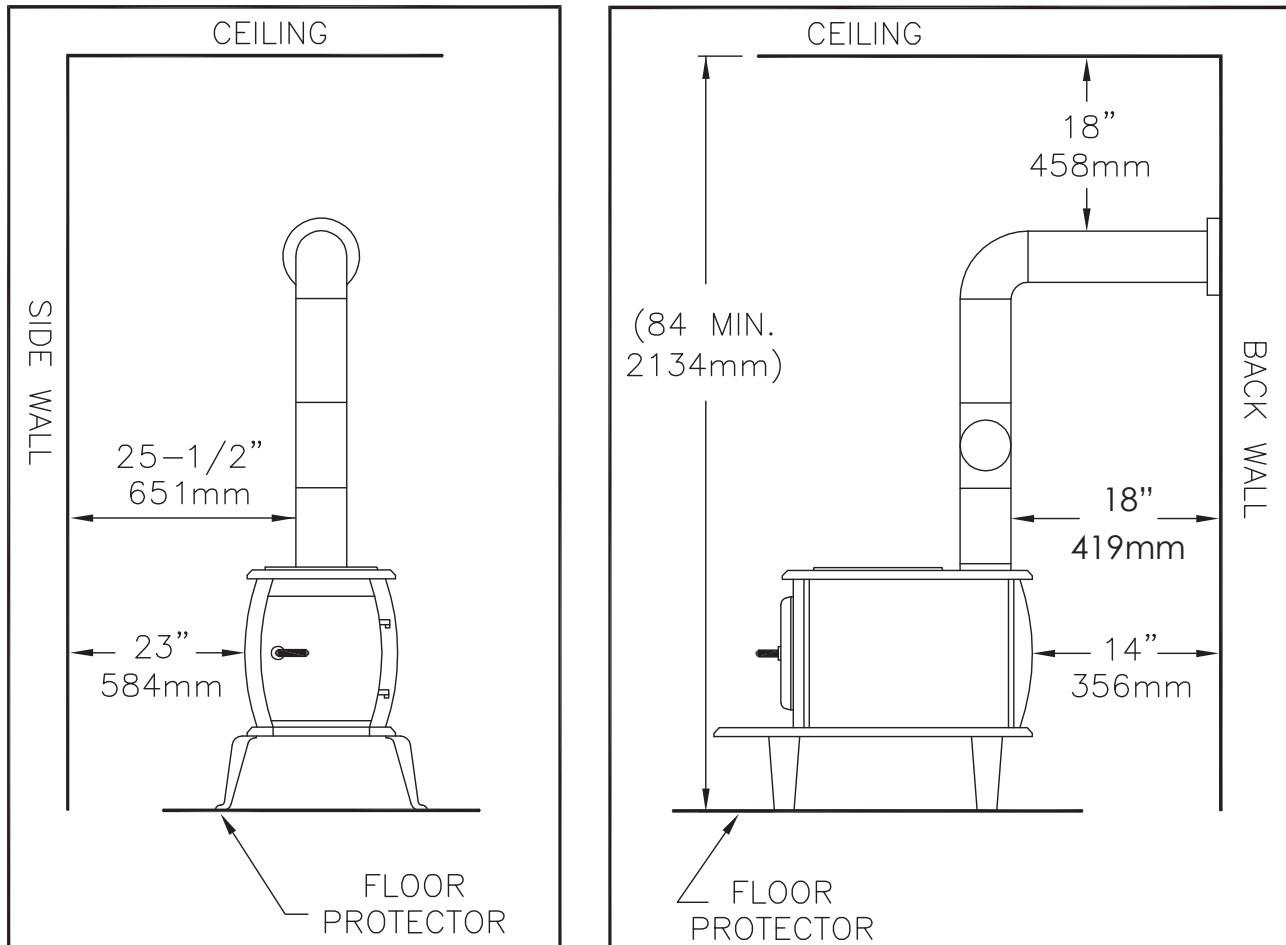

HEATER/FLOOR PROTECTOR LOCATION

(Dimensions are required for non-protected surfaces. See chart for dimensions for protected surfaces.)

Place the heater on solid masonry or solid concrete. When the heater is used on a combustible floor, use an Underwriters Listed floor protector. The floor protector must comply with UL Standards (USA) and CAN/ULC (Canada) and have an R-value of 2.06. The floor protector needs to extend at least 16" beyond the door side of the heater and 8" to each side. It should also extend 8" beyond the rear for Canada. The floor protector needs to extend 2" beyond each side of the flue pipe if it is elbowed towards a wall as well as 2" on each side of the flue for horizontal runs.

1. After consulting the installation instructions for minimum clearances to combustibles, locate your floor protector accordingly and carefully place the stove in your selected location. Install stove pipe, elbows and thimble as necessary, utilizing either a recently cleaned and inspected masonry chimney (properly lined) or a UL, ULC Listed chimney. Insure that the fixed flue baffle that is provided is installed in the flue collar. This baffle is intended to be in a fixed location for optimal combustion. Do not remove or alter the location of this baffle. It is against federal regulations and will void your warranty.
2. Again, check the following illustrations and be sure you have the clearances shown from the heater and the connector pipe to combustibles. If you have a solid brick or stone wall behind your heater, please consult your local building code for specific regulations that may apply in your area. However, if the wall is only faced with brick or stone, consider it a combustible wall. To reduce flue clearances from combustible materials, contact your local safety department.
3. If your chimney drafts excessively, purchase and use a Barometric Draft Regulator (DR6 available from factory).
4. The chimney connection should be as short as possible, and the heater must have its own flue. Do not connect this unit to a chimney flue serving other appliances.

5. Use three sheet metal screws in each stove pipe and or elbow joint to firmly hold the pipe together. Seal around the screws
6. Do not install this heater in a mobile home or trailer.
7. Check your local building and insurance codes. The installation must comply with their rulings.

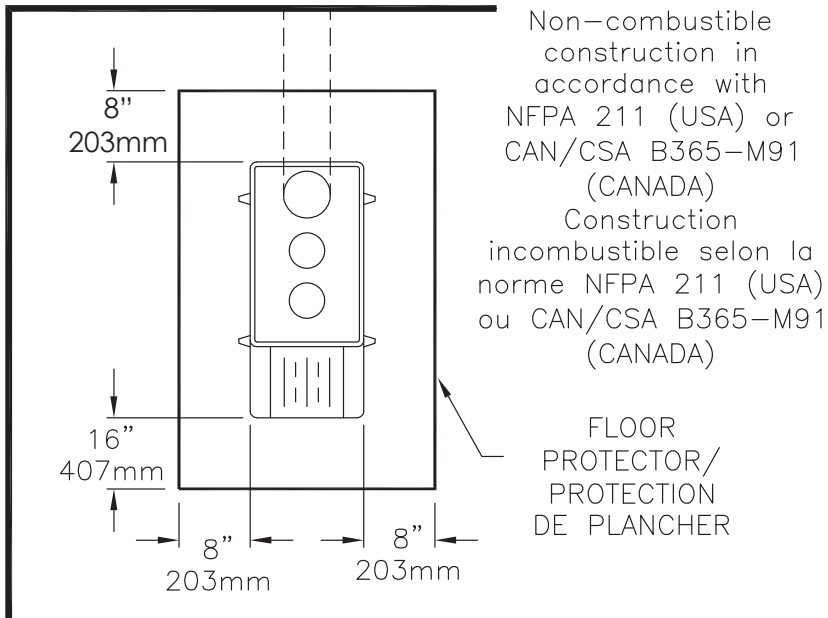

NON-COMBUSTIBLE CONSTRUCTION IN ACCORDANCE WITH NFPA 211

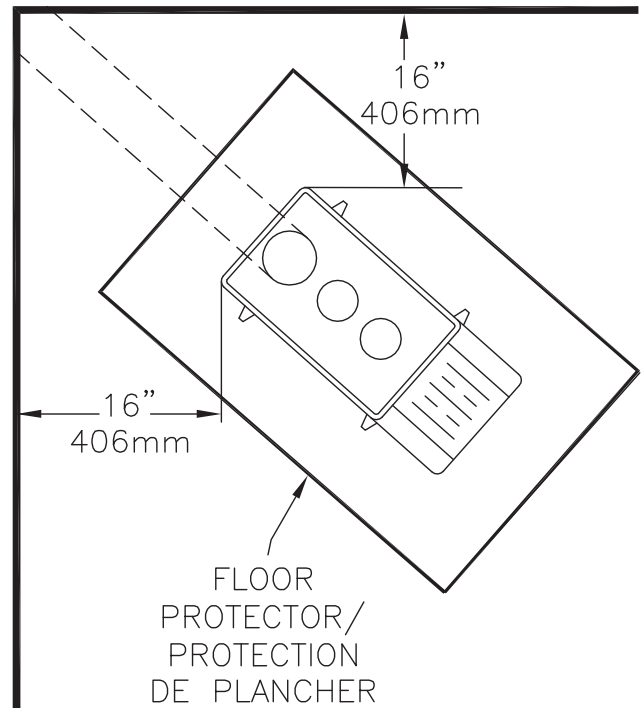

CAUTION!
KEEP FURNISHINGS AND OTHER COMBUSTIBLE MATERIALS AWAY FROM THE HEATER.

Operation Of The Heater

1. Burn wood or wood products only. The wood should be well seasoned prior to use for maximum efficiency.
2. Provide air into the room for combustion.
3. Do Not touch the heater after firing until it has cooled.
4. Do Not use a grate or elevate fire, build fire directly on hearth. The fuel feed door must remain closed during operation.

Chimney Connection

MASONRY CHIMNEY

The masonry chimney must comply with UL, ULC codes. Before using an existing masonry chimney, clean the chimney and inspect the flue liner to be sure it is safe to use. Make repairs before attaching the heater. See Page 3, Item 5. Look at Fig. 5. The connector pipe and fittings you will need to connect directly to a masonry chimney are shown. If the connector pipe must go through a combustible wall before entering the masonry chimney, consult a qualified mason or chimney dealer. The installation must conform to local fire codes, and NFPA 211 (USA) or CAN/CSA-B365-M91 (CANADA). Do not connect this heater into the same chimney flue as the fireplace or flue from another heater. The chimney used for a heater must not be used to ventilate the cellar or basement. If there is a cleanout opening at the base of the chimney, close it tightly.

UL/ULC LISTED CHIMNEY

Carefully follow chimney manufacturer's instructions. Use only listed type HT per UL, ULC 103, 6-in diameter black or blued chimney connector, minimum 24 gauge steel. If your chimney starts at the ceiling (Fig. 6), you will need enough 6" pipe to reach the ceiling.

The top of the chimney must be at least 3 feet above the roof and be at least 2 feet higher than any point of the roof within 10 feet. (Fig 6). Use double or triple wall pipe for the exterior portion of the chimney.

RULES FOR CONNECTOR PIPE INSTALLATION

1. Crimped end of the pipe must be installed toward the heater. The pipe should slide into the flue collar. The pipe should be firmly attached to the flue collar with 3 screws and sealed with furnace cement.
2. Slope any horizontal pipe upward toward the chimney at least 1/4 inch for each foot of horizontal run. Horizontal section must be a minimum of 24" from stove.
3. You must have at least 18" inches clearance between any horizontal piping and the ceiling.
4. The pipe cannot extend into the chimney flue.(Fig. 7)
5. Seal each connector pipe joint with furnace cement. Also, seal the pipe at the chimney. Seal the inside with high temperature silicone and the outside with high temperature tape.
6. Use 3 sheet metal screws at each joint to make the piping rigid.
7. It is recommended that no more than two (2) 90 degree bends be used in the stove pipe installation as more than two (2) may decrease the amount of draw and possibly cause smoke spillage.

NOTE: The chimney connector shall not pass through an attic, roof space, floor, ceiling, or similar concealed space. Where passage through a wall or partition of combustible construction is desired, the installation must conform with CAN/CSA - B365.

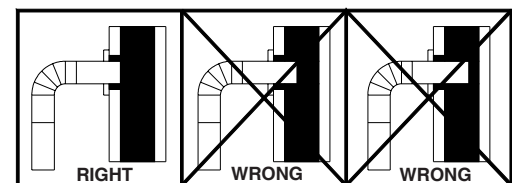
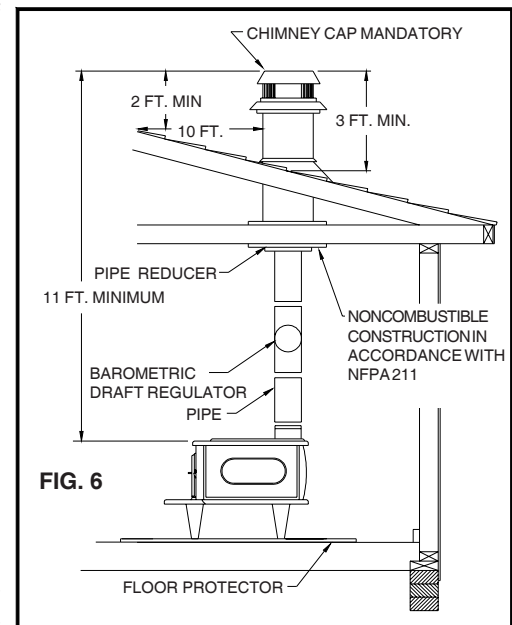
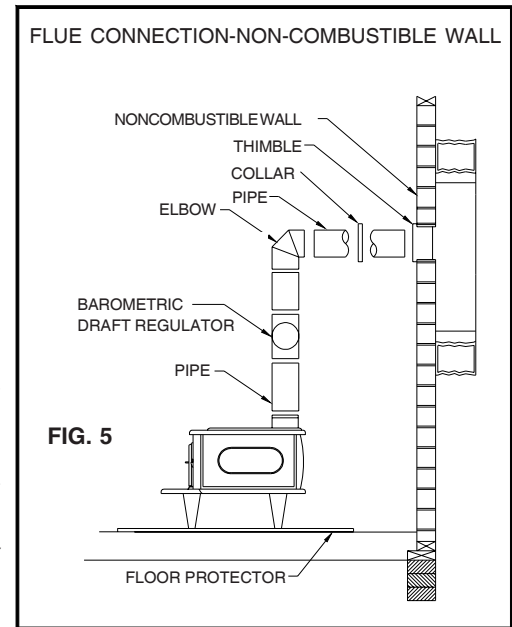
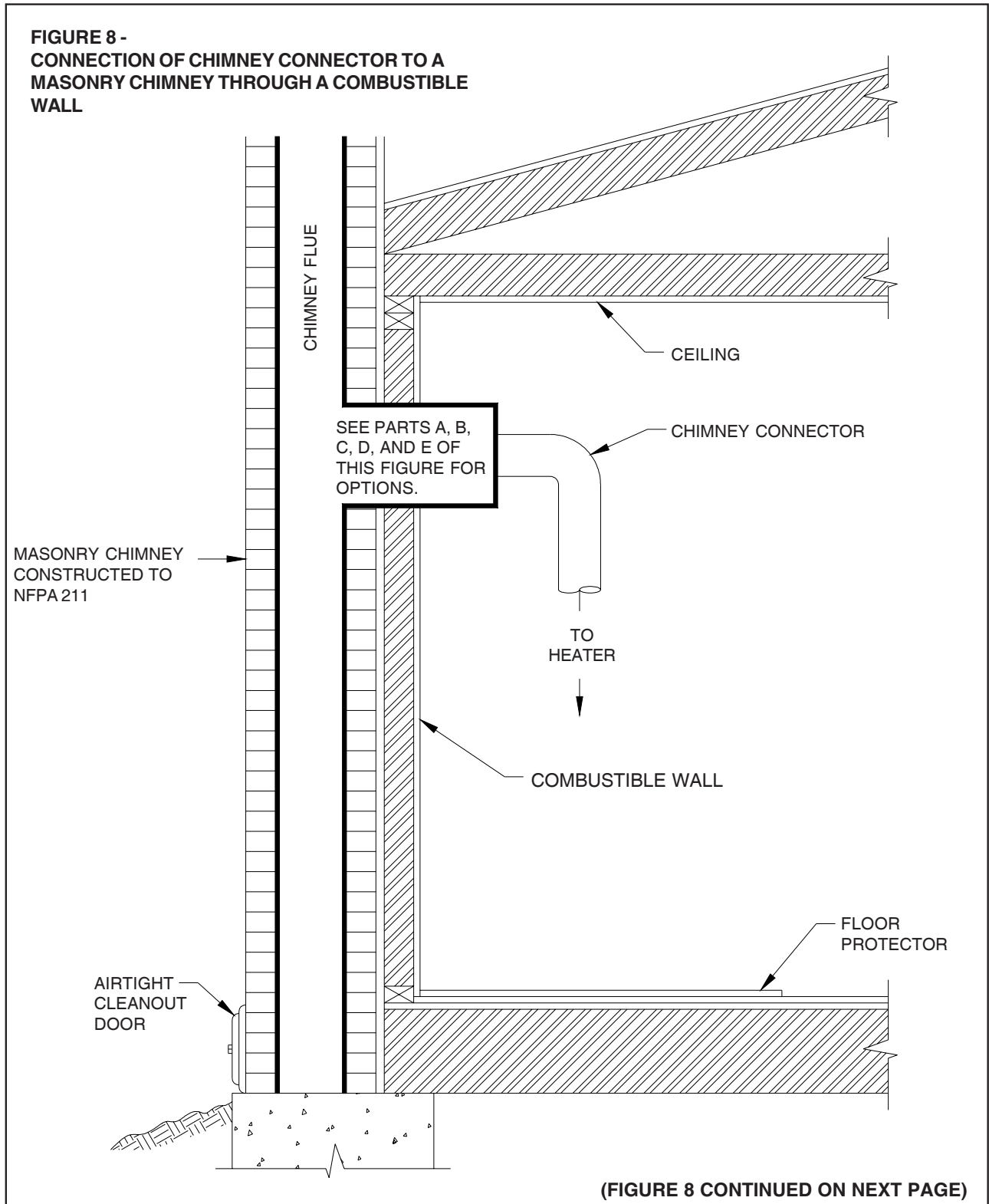

FIG. 7

CONNECTION OF CHIMNEY CONNECTOR TO A MASONRY CHIMNEY THROUGH A COMBUSTIBLE WALL

Figure 8 shows how to connect the chimney connector of a heater to a masonry chimney through a combustible wall.

There are five allowable ways that a chimney connector can be connected to a masonry chimney by passing through a combustible wall. NFPA Standard 211 allows the following wall pass-through systems.



**PART A, FIGURE 8
(FIGURE 8 CONTINUED ON NEXT PAGE)**

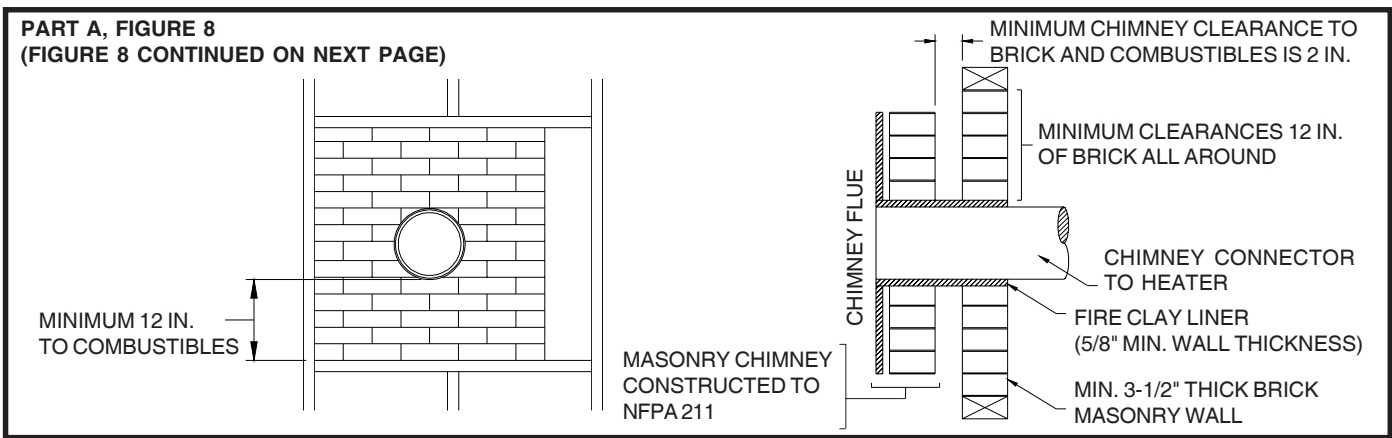

1. Use a minimum 3-1/2" thick brick masonry wall framed into the combustible wall. A fireclay liner (ASTM C315 or equivalent) having a 5/8" minimum wall thickness must be used and it must be at least 12" away from any material that could catch fire. The inside diameter of the fireclay liner shall be sized for the proper snug fit of a 6" diameter chimney connector pipe. The fireclay liner shall run from the outer surface of the brick wall to, but not beyond, the inner surface of the chimney flue and shall be firmly cemented in place. See Part A of Figure 8.
2. Use a solid insulated listed factory-built chimney length having an inside diameter of 6" and having 1" or more of solid insulation. There must be at least a 9" air space between the outer wall of the chimney length and any combustible materials. The inner end of the chimney length shall be flush with the inside of the masonry chimney, the flue shall be sealed to the flue and to the brick masonry penetration with nonwater-soluble refractory cement. Sheet steel supports which are at least 24 gauge (0.024") in thickness shall be securely fastened to wall surfaces on all sides. Fasteners between supports and the chimney length shall not penetrate the chimney liner. See Part B of Figure 8.
3. Use a 10" diameter ventilated thimble made of at least 24 gauge (0.024") steel having two 1" air channels. The ventilated thimble must be separated from combustible materials by a minimum of 6" glass fiber insulation. The opening in the combustible wall shall be covered and the thimble supported with sheet steel supports which are at least 24 gauge (0.024") in thickness. The sheet steel supports shall be securely fastened to wall surfaces on all sides and shall be sized to fit and hold the chimney section. Fasteners used to secure chimney sections shall not penetrate chimney flue liner. See Part C of Figure 8.
4. Use an 8" inside diameter solid insulated listed factory-built chimney length which has 1" or more of solid insulation. The minimum length of this chimney section shall be 12" and will serve as a pass-through for the 6" diameter chimney connector. There must be at least a 12" air space between the outer wall of the chimney section and any combustible materials. The chimney section shall be concentric with and spaced 1" away from the chimney connector by means of sheet steel support plates on both ends of the chimney section. The opening in the combustible wall shall be covered and the chimney section supported on both sides with sheet steel supports which are at least 24 gauge (0.024") in thickness. The sheet steel supports shall be securely fastened to wall surfaces on all sides and shall be sized to fit and hold the chimney section. Fasteners used to secure chimney sections shall not penetrate chimney flue liner. See Part C of Figure 8.
5. A listed factory-built wall pass-through system may be purchased and installed according to the instructions pack aged with it to provide a safe method of passing the chimney connector through a combustible wall for connection to a masonry chimney.

ADDITIONAL REQUIREMENTS PERTAINING TO FIGURE 8 AND THE

ABOVE WALL PASS-THROUGH SYSTEMS

1. Insulation material used as part of wall pass-through system shall be of noncombustible material and shall have a thermal conductivity of 1.0 Btu • in./ft.² • °F (4.88 kg • cal/hr • m² • °C) or less
2. All clearances and thicknesses are minimums; larger clearances and thickness are acceptable.
3. A chimney thimble, as shown for 3" and 4" above (Parts C and D respectively of Figure 8) shall be for types "3" and "4" connections to facilitate removal of the chimney connector for cleaning. The chimney thimble shall be of ASTM C315 fireclay with 5/8" minimum wall thickness, or material of equivalent durability. The inside diameter of the thimble shall be sized for the proper snug fit of a 6" diameter chimney connector pipe. The thimble shall be installed without damage to the chimney flue. The thimble shall extend through the chimney wall to, but not beyond, the inner surface of the chimney flue and shall be permanently cemented in place with high temperature cement.
4. A chimney connector to a masonry chimney, except for 2" above (Part B of Figure 8), shall extend through

the wall pass-through system to the inner face of the chimney flue, but not beyond. It does not have to be fastened in place so long as it cannot accidentally be pulled out of the chimney or shoved into the chimney flue. If fasteners are used to secure the chimney connector to a masonry chimney, the fasteners shall not penetrate the chimney flue liner.

- Any material used to close up any opening for the connector shall be noncombustible.

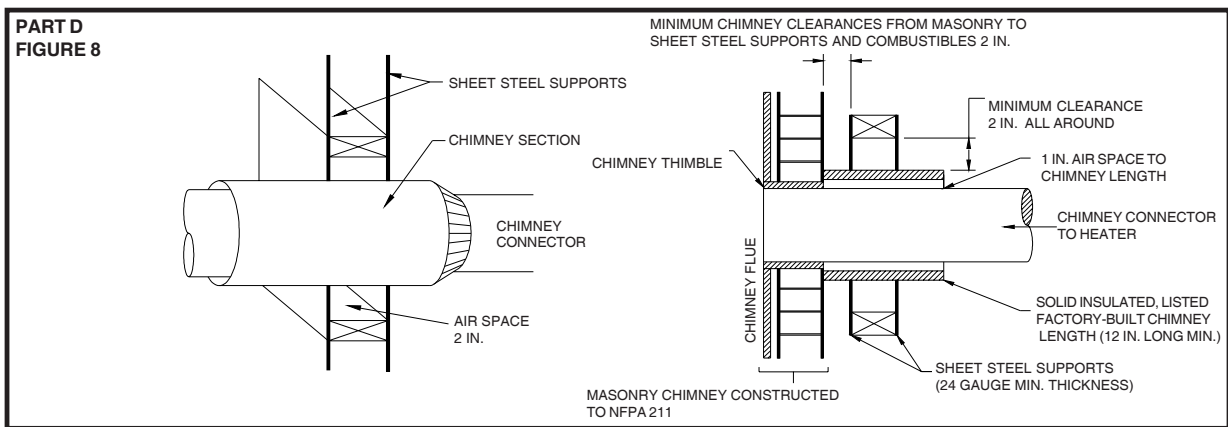
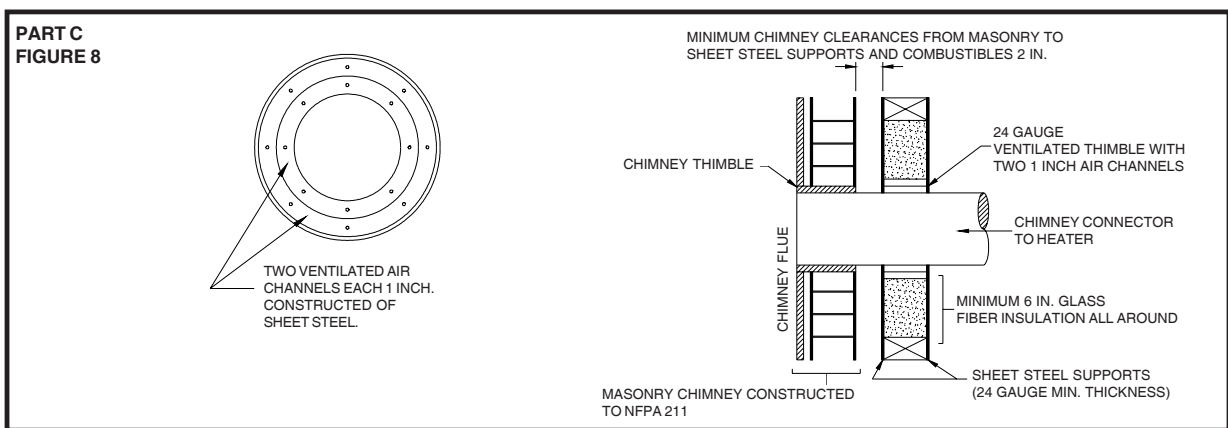
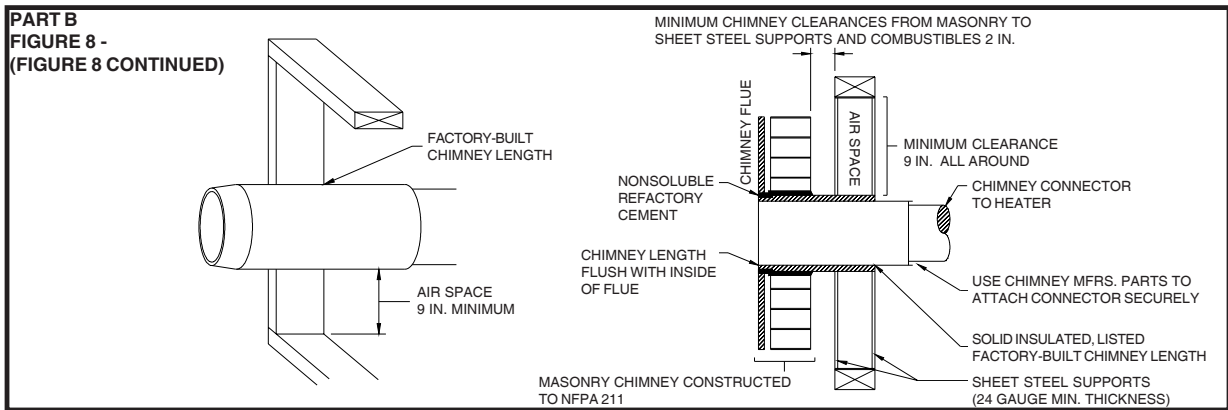

PART E - (FIGURE 8)

In addition to the methods shown by A, B, C, and D of Figure 8, a listed factory-built wall pass-through system may be purchased and installed according to the instructions packaged with it to provide a safe method of passing chimney connector through a combustibile wall for a connection to a masonry chimney.

CONNECTION OF CHIMNEY CONNECTOR TO A MASONRY CHIMNEY WHEN CHIMNEY CONNECTOR DOES NOT PASS THROUGH A COMBUSTIBLE WALL

If the chimney connector does not have to pass through a combustibile wall to get to a masonry chimney, simply connect the chimney connector directly to the masonry chimney's chimney thimble as described and shown by parts C and D of Figure 8. Remember, the chimney connector should extend into the chimney thimble to the inner face of the chimney flue but not beyond; if the chimney connector is extended through the chimney thimble into the chimney flue, resistance to the flow of smoke and gases up the chimney will occur; that flow resistance will have an adverse affect on the operation and performance of the heater and venting system.

CAUTION!
USE WOOD OR WOOD-LIKE MATERIALS ONLY. DO NOT USE COAL OR CHARCOAL. COAL OR CHARCOAL WILL DESTROY THE FIREBOX. DO NOT USE DRIED LUMBER OR TREATED WOOD.

WARNING!
NEVER STORE FLAMMABLE LIQUIDS, ESPECIALLY GASOLINE, IN THE VICINITY OF THE HEATER.

CAUTION!
OVERFIRING THE APPLIANCE MAY CAUSE A HOUSE FIRE. IF A UNIT OR CHIMNEY CONNECTOR GLOWS, YOU ARE OVERFIRING.

WARNING!
DO NOT OBSTRUCT THE SPACE BENEATH THE HEATER

CAUTION!
NEVER USE GASOLINE, GASOLINE-TYPE LANTERN FUEL, KEROSENE, CHARCOAL LIGHTER FLUID, OR SIMILAR LIQUIDS TO START OR "FRESHEN UP" A FIRE IN THE HEATER. KEEP ALL SUCH LIQUIDS WELL AWAY FROM THE HEATER WHILE IT IS IN USE.

WARNING!
NEVER OPERATE THIS HEATER WITH THE FUEL DOOR OPEN.

NOTE:
DO NOT ELEVATE FIRE OR USE WITH A GRATE, BUILD FIRE DIRECTLY ON THE HEARTH.

WARNING!
USE ONLY THE LEGS PROVIDED WITH THIS HEATER. REFER TO STEP 5 IN THE "INSTALLATION" SECTION OF THIS MANUAL.

SERVICE HINTS

Do not expect a heater to draw. It is the chimney that creates the draft. Smoke spillage into the house or excessive buildup of water or creosote in the chimney are warnings that the chimney is not functioning properly. Correct problem before using heater. Possible causes are:

1. The connector pipe may push into the chimney too far, stopping the draft. (Fig. 7)
2. Do not connect two heaters into the same chimney flue.
3. The chimney used for a heater must not be used to ventilate the cellar or basement. If there is a cleanout opening at the base of the chimney, it must be closed tightly.
4. If the chimney is operating too cool, water will condense in the chimney and run back into the stove. Creosote formation will be rapid and may block the chimney. Operate the heater at a high enough fire to keep the chimney warm preventing this condensation.
5. If the fire burns well but sometimes smokes or burns slowly, it may be caused by the chimney top being lower than another part of the house or a nearby tree. The wind blowing over a house or tree, falls on top of the chimney like water over a dam, beating down the smoke. The top of the chimney should be at least 3 feet above the roof and be at least 2 feet higher than any point of the roof within 10 feet.

Chimney Maintenance

CREOSOTE - FORMATION AND NEED FOR REMOVAL

When wood is burned slowly, it produces tar and other organic vapors, which combine with expelled moisture to form creosote. The creosote vapors condense in the relatively cool chimney flue of a slow burning fire. As a result, creosote residue accumulates on the flue lining. When ignited, this creosote makes an extremely hot fire.

The chimney connector and chimney should be inspected at least twice monthly during the heating season to determine if a creosote buildup has occurred.

If creosote has accumulated, it should be removed. Failure to remove creosote may cause a house fire. Creosote may be removed by using a chimney brush or other commonly available materials.

Chimney fires burn very hot. If the chimney connector should glow red, immediately call the fire department, then reduce the fire by blocking/closing the inlet air. Since this is a single burnrate heater you should use a non-combustible material to block inlet air openings. If the fire is burning vigorously, spray a multipurpose dry chemical extinguisher onto the fire in the stove if it can be done safely. Avoid introducing water into the chimney if possible as water could damage the heated flue liner.

CAUTION: A CHIMNEY FIRE MAY CAUSE IGNITION OF WALL STUDS OR RAFTERS WHICH YOU THOUGHT WERE A SAFE DISTANCE FROM THE CHIMNEY. IF YOU HAVE A CHIMNEY FIRE, HAVE YOUR CHIMNEY INSPECTED BY A QUALIFIED PERSON BEFORE USING AGAIN.

WOODSTOVE UTILIZATION

Your heating unit was designed to burn wood only; no other materials should be burned. Waste and other flammable materials should not be burned in your stove. Any type of wood may be used in your stove, but specific varieties have better energy yields than others. Please consult the following table in order to make the best possible choice.

TYPE	WEIGHT (LBS. CU. FT., DRY)	PER CORD	EFFICIENCY RANKING	SPLITS	M I L L I O N S BTU's/CORD
Hickory	63	4500	1.0	Well	31.5
White Oak	48	4100	.9	Fair	28.6
Red Oak	46	3900	.8	Fair	27.4
Beech	45	3800	.7	Hard	26.8
Sugar Maple	44	3700	.6	Fair	26.2
Black Oak	43	3700	.6	Fair	25.6
Ash	42	3600	.5	Well	25.0
Yellow Birch	40	3400	.4	Hard	23.8
Red Maple	38	3200	.3	Fair	22.6
Paper Birch	37	3100	.3	Easy	22.1
Elm/Sycamore	34	2900	.2	Very Difficult	20.1
Red Spruce	29	1800	.1	Easy	16.1

It is EXTREMELY IMPORTANT that you use DRY WOOD only in your wood stove. The wood should have dried for 9 to 15 months, such that the humidity content (in weight) is reduced below 20% of the weight of the log. It is very important to keep in mind that even if the wood has been cut for one, two or even more years, it is not necessarily dry if it has been stored in poor conditions.

Under extreme conditions it may rot, instead of drying. This point cannot be over stressed; the vast majority of the problems related to the operation of a wood stove is caused by the fact that the wood used was too damp or has dried in poor conditions. These problems can be:

- ignition problems
- creosote build-up causing chimney fires
- low energy yield
- blackened windows
- incomplete log combustion

Smaller pieces of wood will dry faster. All logs exceeding 6" in diameter should be split. The wood should not be stored directly on the ground. Air should circulate through the cord. A 24" to 48" air space should be left between each row of logs, which should be placed in the sunniest location possible. The upper layer of wood should be protected from the elements but not the sides.

TESTING YOUR WOOD

When the stove is thoroughly warmed, place one piece of split wood (about five inches in diameter) parallel to the door on the bed of red embers.

Keep the air control full open by pulling on it and close the door. If ignition of the piece is accomplished within 90 seconds from the time it was placed in the stove, your wood is correctly dried. If ignition takes longer, your wood is damp.

If your wood hisses and water or vapor escapes at the ends of the piece, your wood is soaked or freshly cut. Do not use this wood in your stove. Large amounts of creosote could be deposited in your chimney, creating potential conditions for a chimney fire.

THE FIRST FIRES

The fresh paint on your stove needs to be cured to preserve its quality. Once the fuel charge is properly ignited, only burn small fires in your stove for the first four hours of operation.

Make sure that there's enough air circulation while curing the stove. The odors could be smelled during the 3 or 4 first fires. Never start your stove outside. You will not be able to see if you are over heating.

CAUTION:

NEVER ALTER THE DAMPER SLIDE OR THE ADJUSTMENT RANGE TO INCREASE FIRING RING FOR ANY REASON. DOING SO COULD RESULT IN HEATER DAMAGE AND WILL VOID YOUR WARRANTY.

WARNINGS:

- NEVER OVERFIRE YOUR STOVE. IF ANY PART OF THE STOVE STARTS TO GLOW RED, OVER FIRING IS HAPPENING.
- THE INSTALLATION OF A LOG CRADLE OR GRATES IS NOT RECOMMENDED IN YOUR WOOD STOVE BUILD FIRE DIRECTLY ON HEARTH.

RELOADING

Once you have obtained a good bed of embers, you should reload the unit. Open the door very slowly; open it one or two inches for 5 to 10 seconds, before opening it completely to increase the draft and thus eliminate the smoke which is stagnant in a state of slow combustion in the stove. Then bring the red embers to the front of the stove and reload the unit.

It is important to note that wood combustion consumes ambient oxygen in the room. In the case of negative pressure, it is a good idea to allow fresh air in the room, either by opening a window slightly or by installing a fresh air intake system on an outside wall.

Creosote - Formation and Need for Removal - When wood is burned slowly, it produces tar and other organic vapors, which combine with expelled moisture to form creosote. The creosote vapors condense in the relatively cool chimney flue of a slow-burning fire. As a result, creosote residue accumulates on the flue lining. When ignited, this creosote makes an extremely hot fire. The chimney connector and chimney should be inspected at least once every two months during the heating season to determine if a creosote build-up has occurred. If creosote has accumulated (3mm or more), it should be removed to reduce the risk of a chimney fire.

We strongly recommend that you install a magnetic thermometer on your smoke exhaust pipe, approximately 18" above the stove. This thermometer will indicate the temperature of your gas exhaust fumes within the smoke exhaust system. The ideal temperature for these gases is somewhere between 275°F and 500°F. Below these temperatures, the build-up of creosote is promoted. Above 500 degrees, heat is wasted since a too large quantity is lost into the atmosphere.

TO PREVENT CREOSOTE BUILD UP

- Always burn dry wood. This allows clean burns and higher chimney temperatures, therefore, less creosote deposit.
- The secondary combustion can only take place if the firebox is hot enough.
- Always check for creosote deposit once every two months and have your chimney cleaned at least once a year.

If a chimney or creosote fire occurs, close all dampers (if applicable) immediately. Wait for the fire to go out and the heater to cool, then inspect the chimney for damage. If no damage results, perform a chimney cleaning to ensure there is no more creosote deposits remaining in the chimney.

CAUTIONS:

- **ASHES COULD CONTAIN HOT EMBERS EVEN AFTER TWO DAYS WITHOUT OPERATING THE STOVE.**

MAINTENANCE

Your wood stove is a high efficiency stove and, therefore requires little maintenance. It is important to perform a visual inspection of the stove every time it is emptied, in order to insure that no parts have been damaged, in which case repairs must be performed immediately. Inspect and clean the chimney and connector pipe periodically for creosote buildup or obstructions.

GASKETING

It is recommended that you change the door gasket (which makes your stove door air tight) once a year, in order to insure good control over the combustion, maximum efficiency, and security. To change the door gasket, simply remove the damaged one. Carefully clean the available gasket groove, apply a high temperature silicone sold for this purpose and install the new gasket. You may light up your stove again approximately 24 hours after having completed this operation.

WARNING:

- **NEVER OPERATE THE STOVE WITHOUT A GASKET OR WITH A BROKEN ONE. DAMAGE TO THE STOVE OR EVEN HOUSE FIRE MAY RESULT.**

PAIN

Only clean your stove with a dry soft cloth that will not harm the paint finish. If the paint becomes scratched or damaged, it is possible to give your wood stove a brand new look, by repainting it with a 1200° F heat resistant paint. For this purpose, simply scrub the surface to be repainted with fine sand paper, clean it properly, and apply thin coats (2) of paint successively.

SECONDARY AIR TUBES

The secondary air tubes must be cleaned with a wire brush. If debris remains in holes lightly tap with a wooden stick to remove.

PARTS DIAGRAM

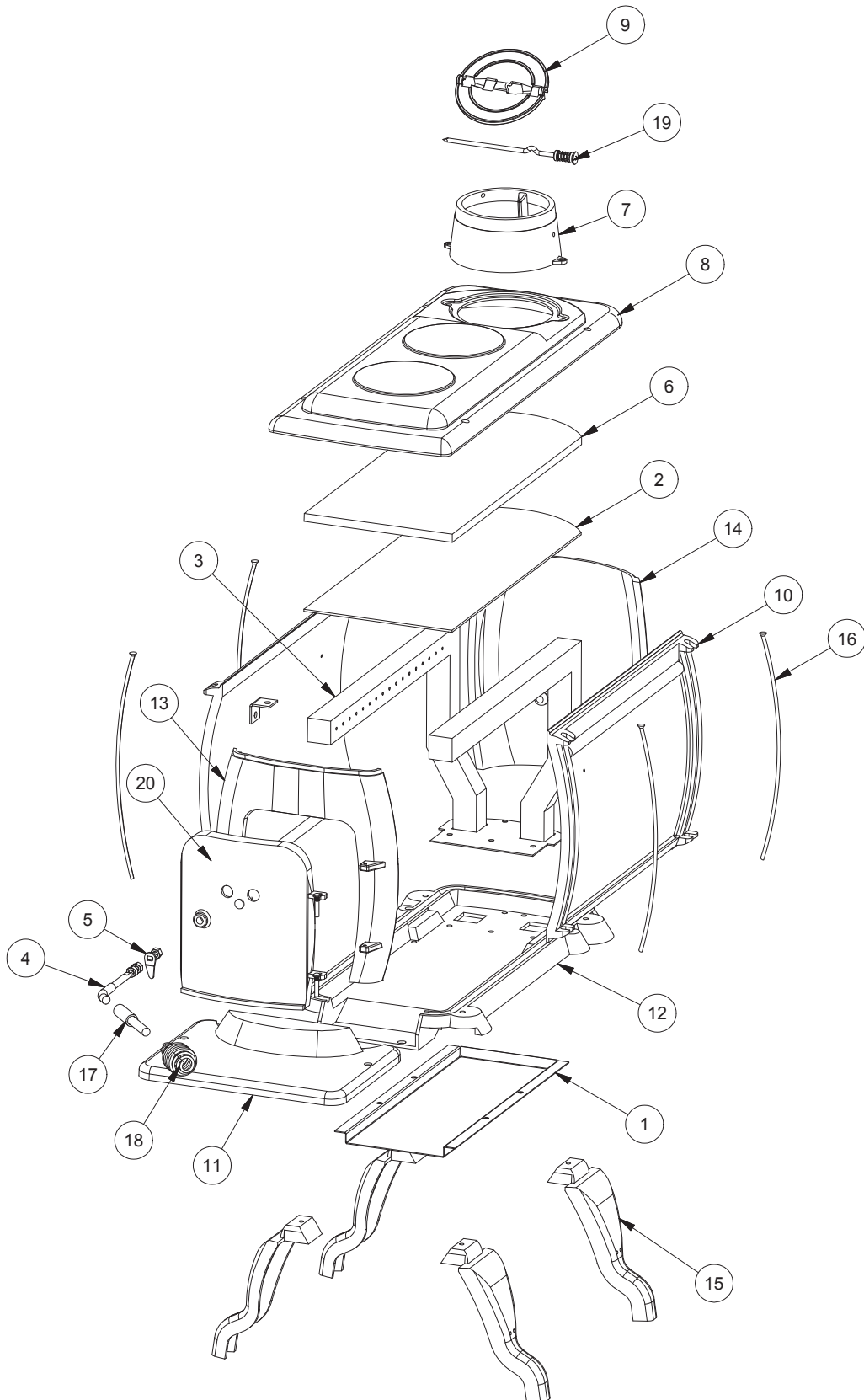

PARTS LIST

KEY	PART NO.	DESCRIPTION	QTY.
1	892508	Bottom Channel	1
2	892510	Baffle	1
3	86802	Bent Tube Right	1
4	892516	Tube Weldment	1
5	89972	Latch	1
6	88228	Kao Wool	1
7	40309	Flue Collar	1
8	40774	Main Top	1
9	40398	Flue Baffle (to be fixed)	1
10	40775	Main Side	2
11	40771	Hearth Extension	1
12	40772	Floor	1
13	40302	Door Frame	1
14	40298	Main Back	1
15	40318	Leg	4
16	892533	Rod	4
17	89974	Handle Extension	1
18	891135	Handle, Spring (Lg-Nickel)	1
19	892520	Centering Pin (w/spring)	1
20	40773	Feed Door	1

CAUTION:

NEVER ALTER THE DAMPER SLIDE OR THE ADJUSTMENT RANGE TO INCREASE FIRING RING FOR ANY REASON. DOING SO COULD RESULT IN HEATER DAMAGE AND WILL VOID YOUR WARRANTY.

Limited Warranty

The operation of this appliance in a manner inconsistent with the owner's manual will void your warranty and is also against federal regulations.

United States Stove Company warrants to the original purchaser its products against premature failure of any component due to workmanship, quality, or materials as follows:

TIME PERIOD:

Firebox	One Year
Flue Collar - if equipped	One Year
All Doors.....	One Year
Firebox Baffle.....	One Year
Door Gaskets	One Year
All Electrical Components (Including Blower) - if equipped.....	One Year
Cabinet and Trim	One Year

CLAIM PROCEDURE

Any defects should be reported to United States Stove Company or its dealer and/or distributor giving descriptions and pertinent data, including proof of purchase which will be returned upon request.

Providing the heater has been installed and used in accordance with the Owners Manual supplied with the heater, United States Stove Company will either:

- 1) Replace the defective part free of charge
- 2) Replace the heater free of charge
- 3) Where the defect is of a cosmetic (non-functional) nature, United States Stove Company will bear reasonable expense to refurbish the heater, including such items as welding, painting, and incidental labor. A "Reasonable" is defined by terms of this warranty as \$30.00/hour with full refund for any purchase of parts.

NOT COVERED

Specifically not covered under terms of this limited warranty or any other warranty are problems relating to smoking or creosote. Smoking is attributable to inadequate draft due to the design or installation of the flue system or installation of the heater itself. Creosote formation is largely attributable to improper operation of the unit and/or draft as mentioned above. Also, not covered are:

- 1) Removal and re-installation cost.
- 2) Service calls to diagnose trouble (unless authorized in writing by the manufacturer, distributor, or dealer).
- 3) Painted surfaces, brass or brass-colored surfaces.
- 4) Damage or defect caused by improper installation, accidents, misuse, abuse (including over firing) or alteration.
- 5) Transportation or shipping costs.

LIMITATIONS AND EXCLUSIONS

- 1) United States Stove Company shall not be liable for incidental, consequential, special, or contingent damages anyone might suffer as a result of their breach of this written warranty or any implied warranty.
- 2) Should the heater be replaced by United States Stove Company "free of charge", all further warranty obligations are thereby met.
- 3) Parts and/or service replacements made under the terms of this warranty are warranted only for the remaining period of the original heater warranty.
- 4) Without specific written exclusionary waivers, no one has authority to add to or vary this limited warranty, or to create for United States Stove Company any further obligation of liability in connection with this heater or any other applicable accessory. Any further warranty implication applicable to this heater or any applicable accessory is limited in duration to the same time period as the original statement in the above schedule.

YOUR DUTIES

- 1) This heater, including all applicable accessories, must be installed and operated in accordance with local authorities having jurisdiction and the instructions furnished with the Owners Manual.
- 2) You should keep as permanent record your proof of purchase (or canceled check or invoice).

PROBLEM/RESOLUTION

- 1) As purchaser, you must first contact the dealer and/or distributor from whom you purchased your heater.
- 2) If within a reasonable period of time you do not receive satisfactory service from the distributor and/or dealer, write or call United States Stove Company, Customer Service Department, including complete details of the problem and/or problems you are experiencing, details of your installation, your proof of purchase, and the heater serial number or test agency code number.

WARRANTOR

The warrantor of record is United States Stove Company, PO Box 151, 227 Industrial Drive, South Pittsburg, Tennessee 37380. Phone number 800-750-2723.

NOTE

This warranty gives you specific legal rights; and, you may also have other rights which vary from state to state.

SERVICE RECORD

It is recommended that your heating system is serviced regularly and that the appropriate Service Interval Record is completed.

Service Provider:

Before completing the appropriate Service Record below, please ensure you have carried out the service as described in the manufacturer's instructions. Always use the manufacturer's specified spare part when replacement is necessary.

Service 01	Date: _____
Engineer Name: _____	
License No.: _____	
Company: _____	
Telephone No.: _____	
Stove Inspected: <input type="checkbox"/> Chimney Swept: <input type="checkbox"/>	
Items Replaced: _____	

Service 02	Date: _____
Engineer Name: _____	
License No.: _____	
Company: _____	
Telephone No.: _____	
Stove Inspected: <input type="checkbox"/> Chimney Swept: <input type="checkbox"/>	
Items Replaced: _____	

Service 03	Date: _____
Engineer Name: _____	
License No.: _____	
Company: _____	
Telephone No.: _____	
Stove Inspected: <input type="checkbox"/> Chimney Swept: <input type="checkbox"/>	
Items Replaced: _____	

Service 04	Date: _____
Engineer Name: _____	
License No.: _____	
Company: _____	
Telephone No.: _____	
Stove Inspected: <input type="checkbox"/> Chimney Swept: <input type="checkbox"/>	
Items Replaced: _____	

Service 05	Date: _____
Engineer Name: _____	
License No.: _____	
Company: _____	
Telephone No.: _____	
Stove Inspected: <input type="checkbox"/> Chimney Swept: <input type="checkbox"/>	
Items Replaced: _____	

Service 06	Date: _____
Engineer Name: _____	
License No.: _____	
Company: _____	
Telephone No.: _____	
Stove Inspected: <input type="checkbox"/> Chimney Swept: <input type="checkbox"/>	
Items Replaced: _____	

Service 07	Date: _____
Engineer Name: _____	
License No.: _____	
Company: _____	
Telephone No.: _____	
Stove Inspected: <input type="checkbox"/> Chimney Swept: <input type="checkbox"/>	
Items Replaced: _____	

Service 08	Date: _____
Engineer Name: _____	
License No.: _____	
Company: _____	
Telephone No.: _____	
Stove Inspected: <input type="checkbox"/> Chimney Swept: <input type="checkbox"/>	
Items Replaced: _____	

NOTES

NOTES

HOW TO ORDER REPAIR PARTS

THIS MANUAL WILL HELP YOU OBTAIN EFFICIENT, DEPENDABLE SERVICE FROM THE HEATER, AND ENABLE YOU TO ORDER REPAIR PARTS CORRECTLY.

KEEP IN A SAFE PLACE FOR FUTURE REFERENCE.

WHEN WRITING, ALWAYS GIVE THE FULL MODEL NUMBER WHICH IS ON THE NAMEPLATE ATTACHED TO THE BACK OF THE HEATER.

WHEN ORDERING REPAIR PARTS, ALWAYS GIVE THE FOLLOWING INFORMATION AS SHOWN IN THIS LIST:

1. The PART NUMBER _____
2. The PART DESCRIPTION _____
3. The MODEL NUMBER _____
4. The SERIAL NUMBER _____

UNITED STATES STOVE COMPANY
227 Industrial Park Road
P.O. Box 151
South Pittsburg, TN 37380
(423) 837-2100
www.USSTOVE.com