

Item #: BWQCHEV

Assembly Instructions

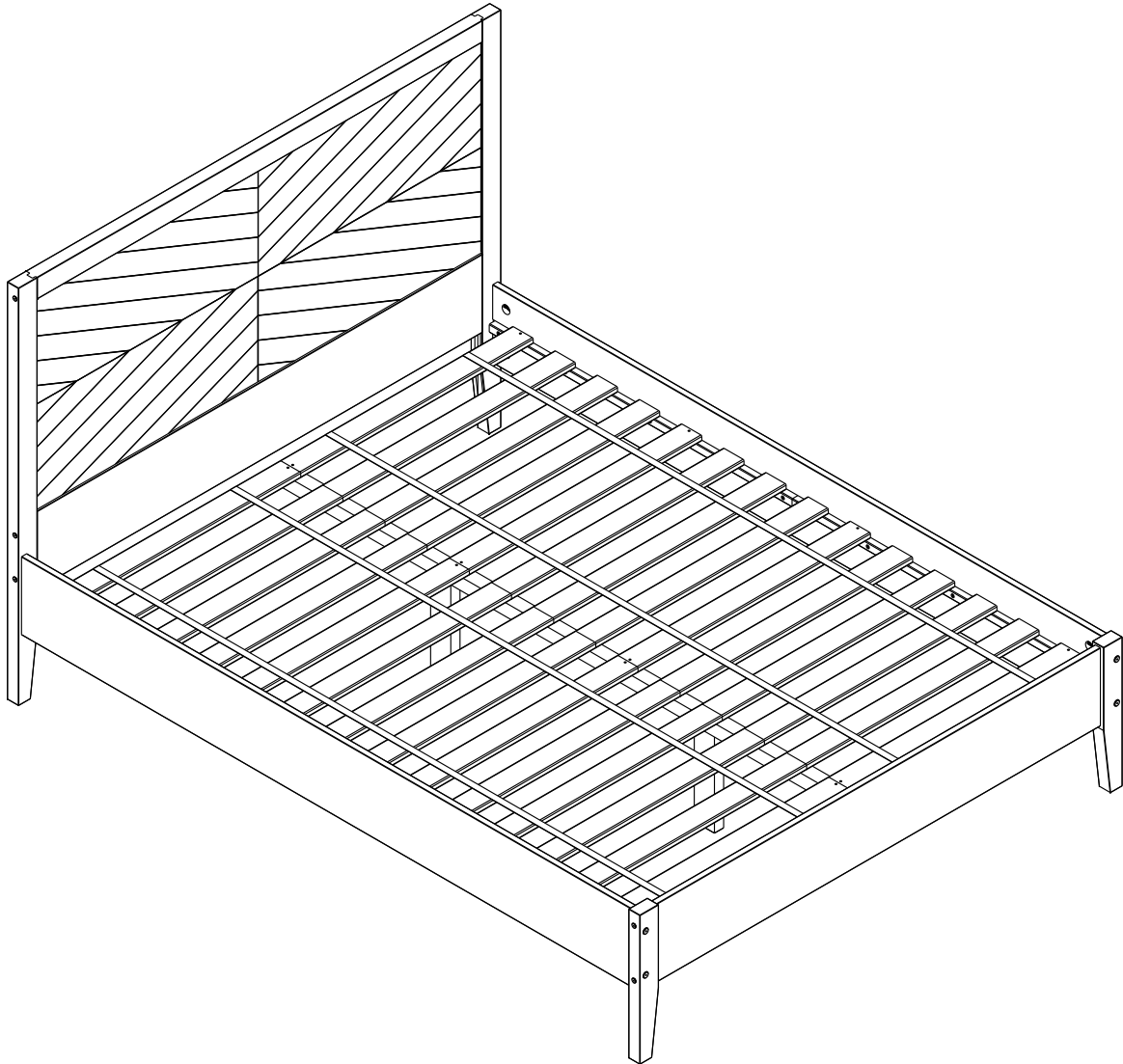

Walker
Edison®

Please visit our website for the most current instructions, assembly tips report damage, or request parts. www.walkerediton.com

Revised 08/2018

General Assembly Guidelines

- I. Ensure that all parts and hardware are available before beginning assembly.
- II. Follow each step carefully to ensure the proper assembly of this product.
- III. Two people are recommended for ease in the assembly of this product.
- IV. The three main types of hardware used to assemble this product are : wood dowels , screws and bolts.
- V. A Phillips head screwdriver is required for the assembly of this product .

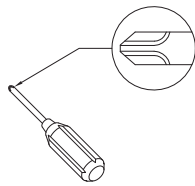



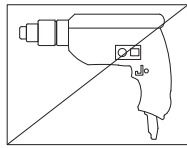



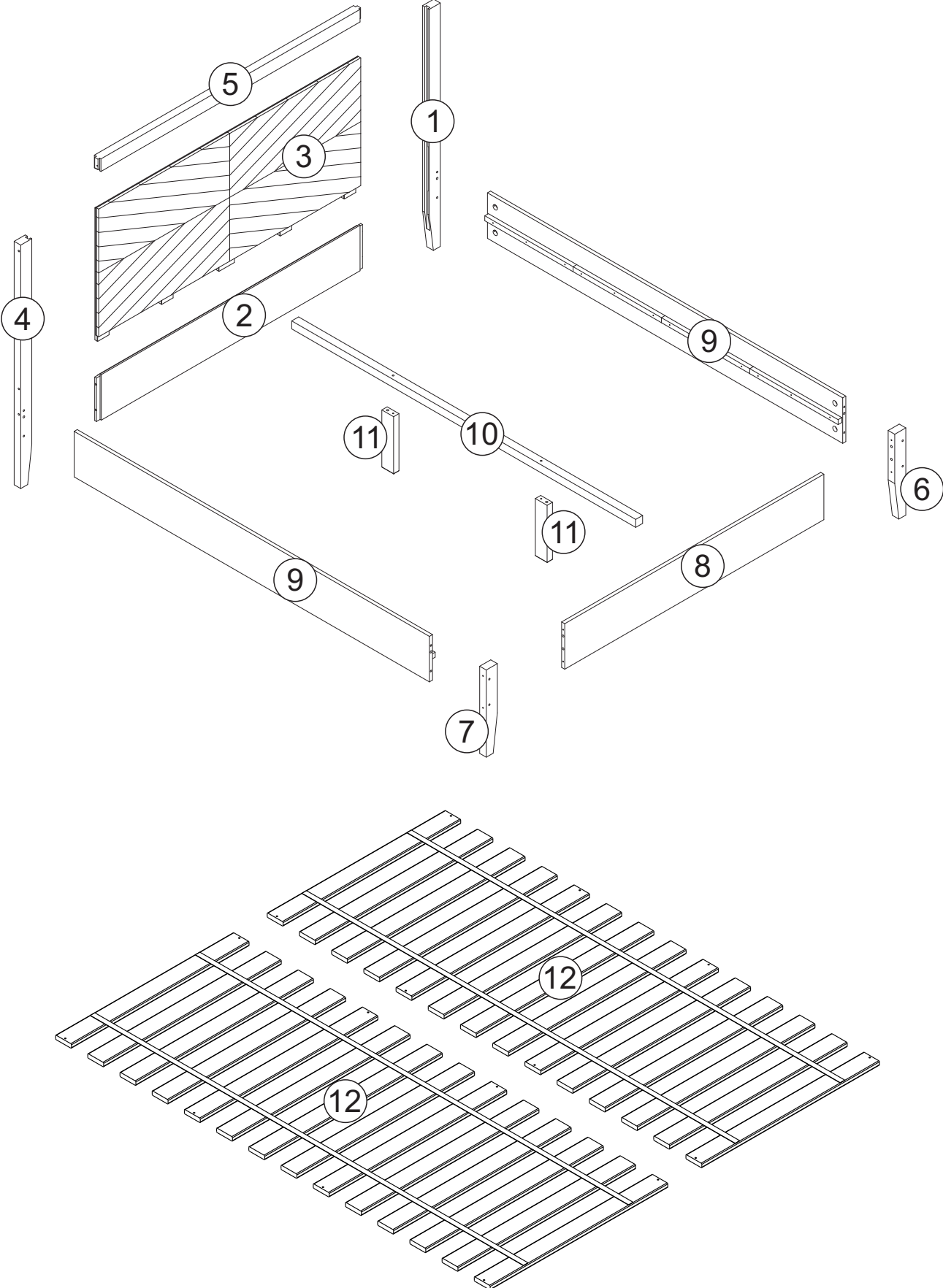

- VI. Power tools should not be used to assemble this product .



Parts List

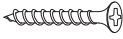

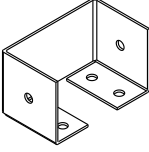
Hardware List

A		Ø 1/4"x90 mm	Bolt	08 pcs
B		Ø 7.0x100 mm	Bolt	10 pcs
C		Ø 7.0x70 mm	Bolt	02 pcs
D		Ø 4.0x30 mm	Screw	22 pcs
E		Ø 3.0x16 mm	Screw	06 pcs
F		Ø 10x40 mm	Wood dowel	10 pcs
G		Ø 1/4"	Barrel nut	08 pcs
H			Bracket	01 pcs
I		M4	Hex key	01 pcs

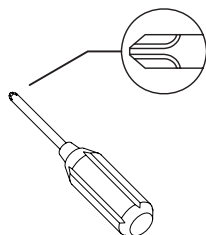
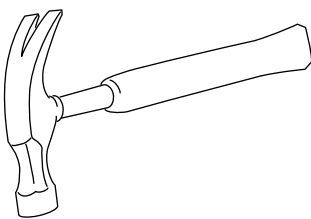

Philips head screwdriver required for assembly
(not included)

Mallet or hammer recommended for assembly
(not included)

*The hardware quantities listed above are required for proper assembly.
Some extra hardware may also have been included.*

Step 1

Insert wood dowel (F) into rails (8, 9) and slat legs (11).

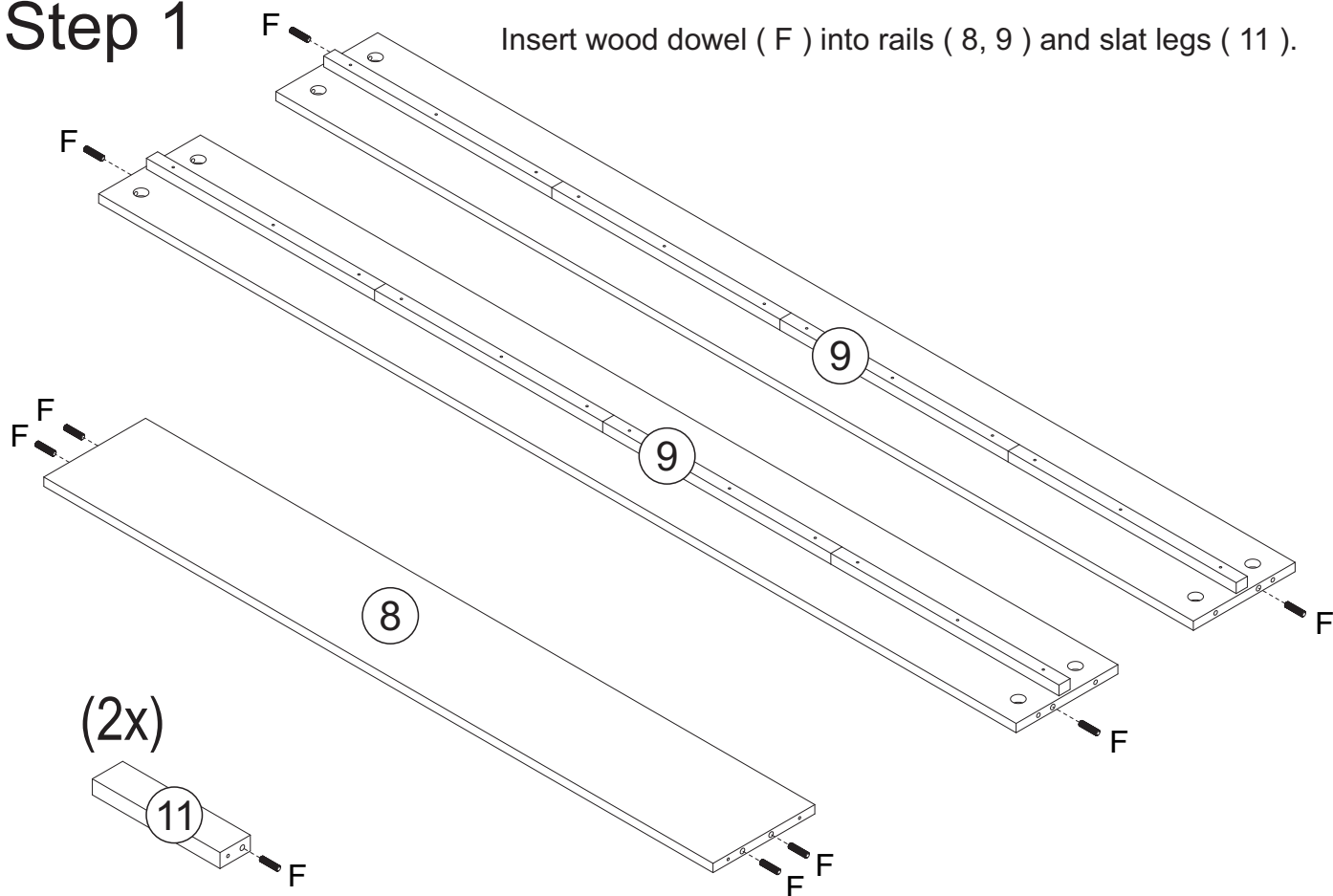

Step 2

Attach leg (1, 4) to slat (2) using bolt (B).

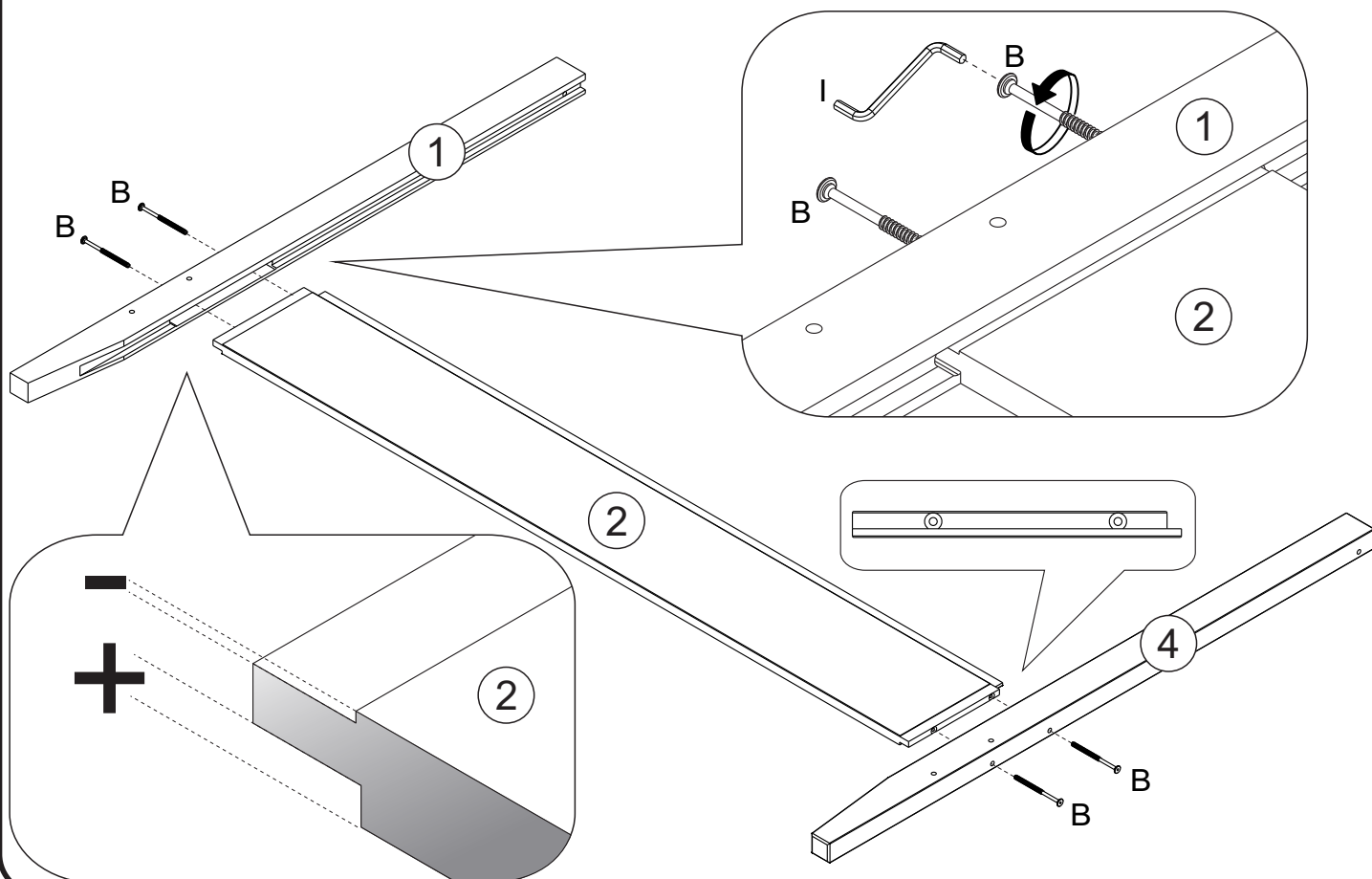

Step 3

Slide headboard (3) into slat (2) gently. Ensure headboard (3) is pressed firmly against leg (1, 4).

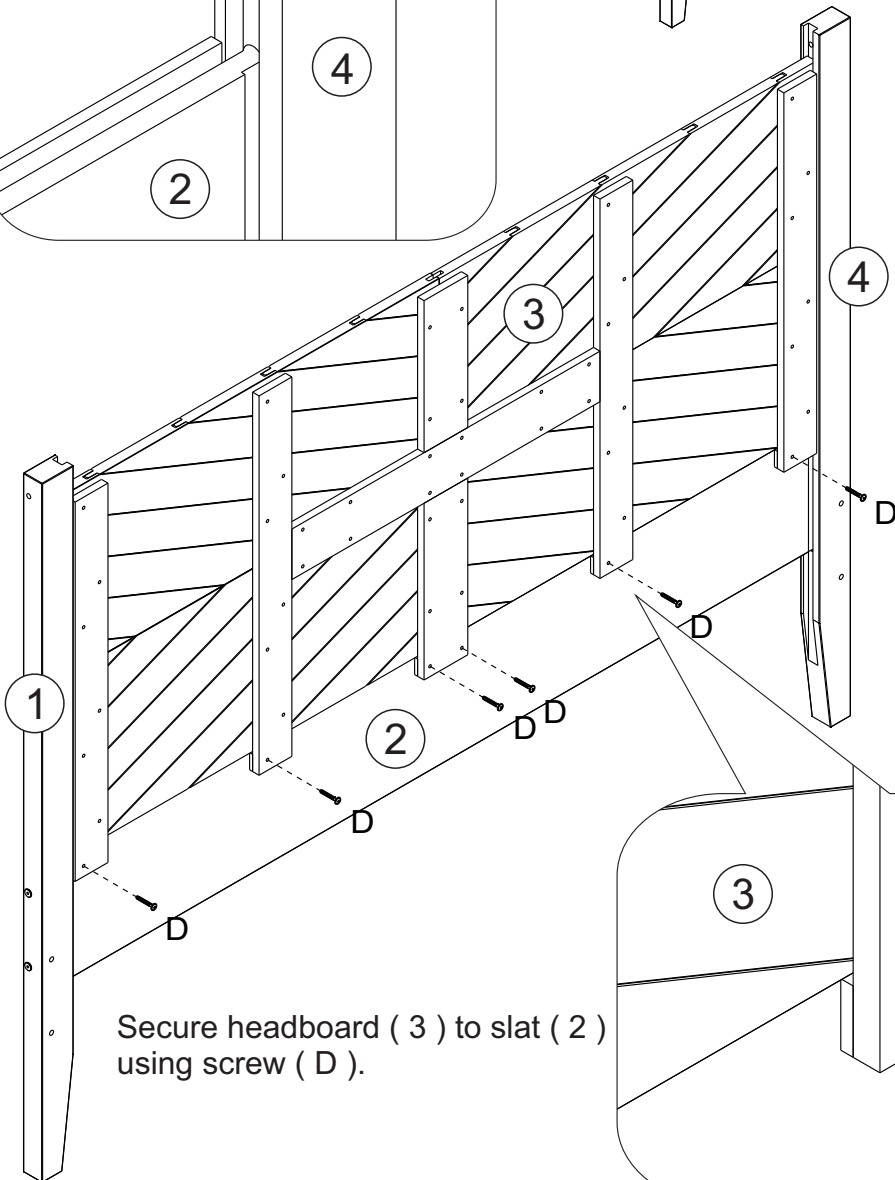
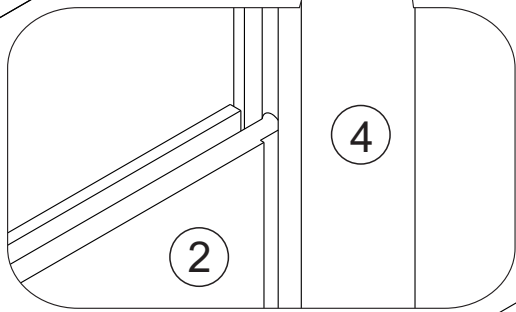
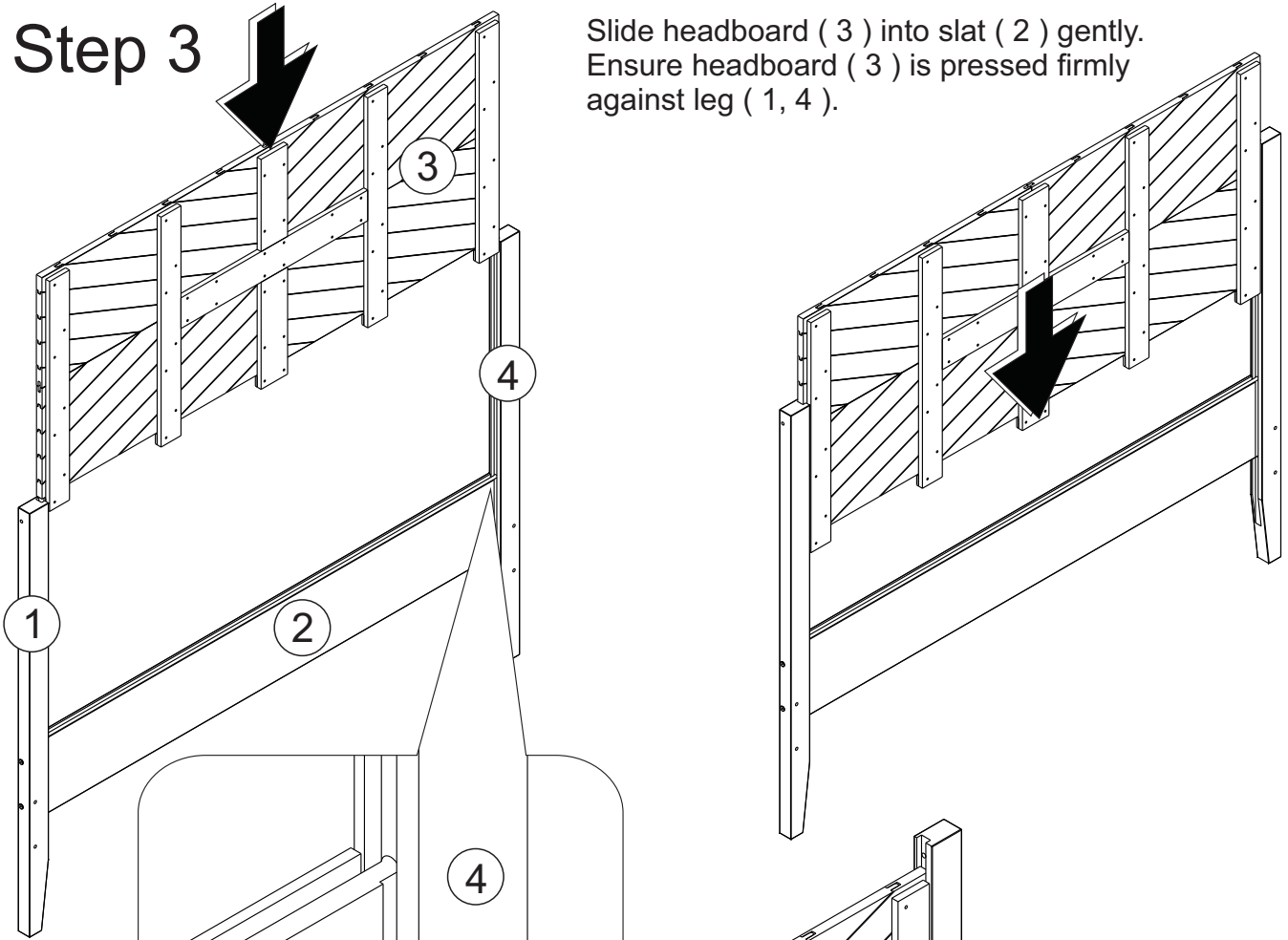

Secure headboard (3) to slat (2) using screw (D).

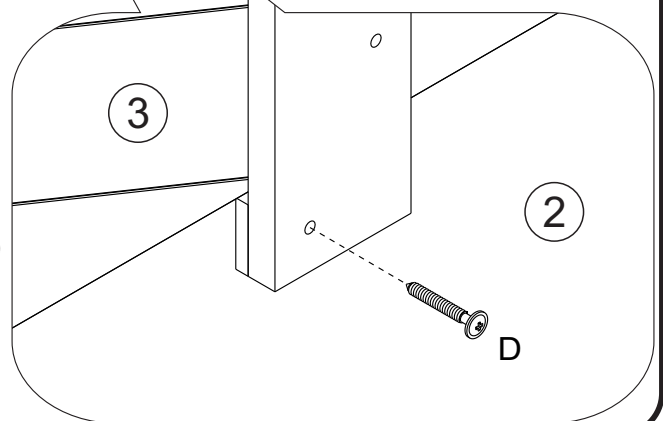

Step 4

Attach headboard cap (5) to headboard (3) using bolt (B).
Ensure headboard cap (5) sits flush on top of headboard (3).

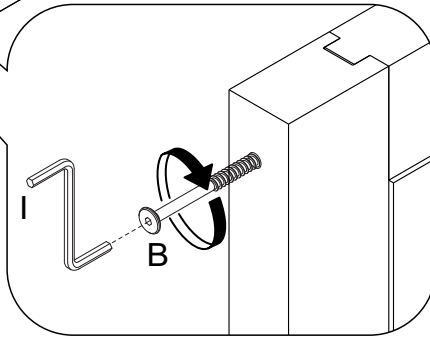
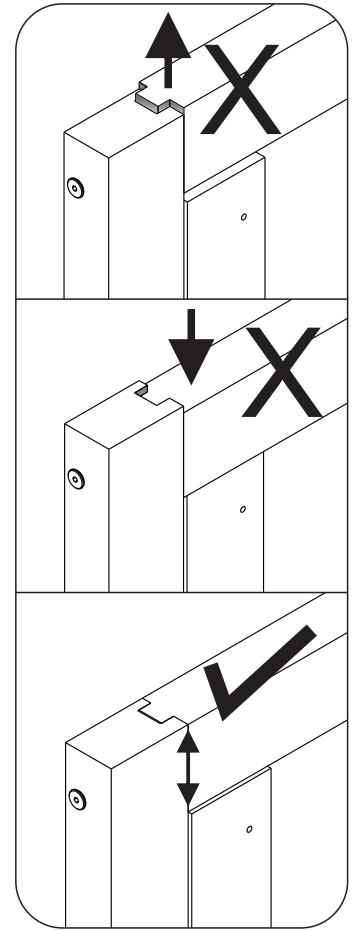
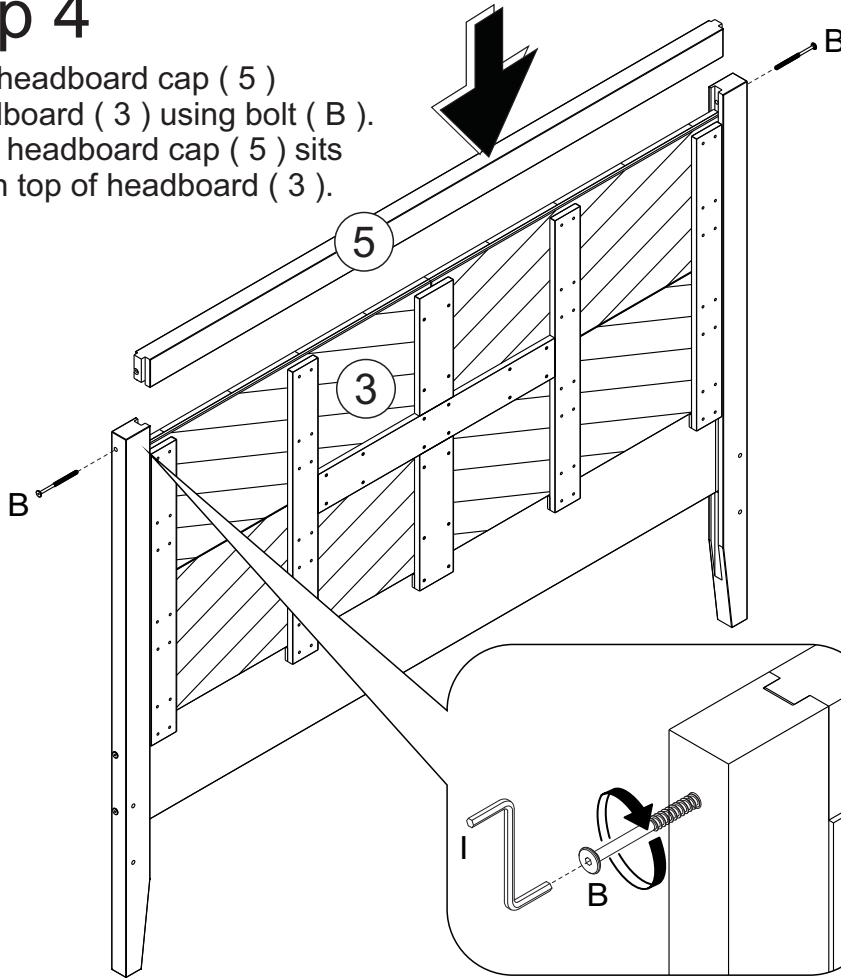

Step 5

Attach legs (6, 7) to slat (8) using bolt (B).
Attach bracket (H) to pre-drilled holes on the slat (8) using screw (E).

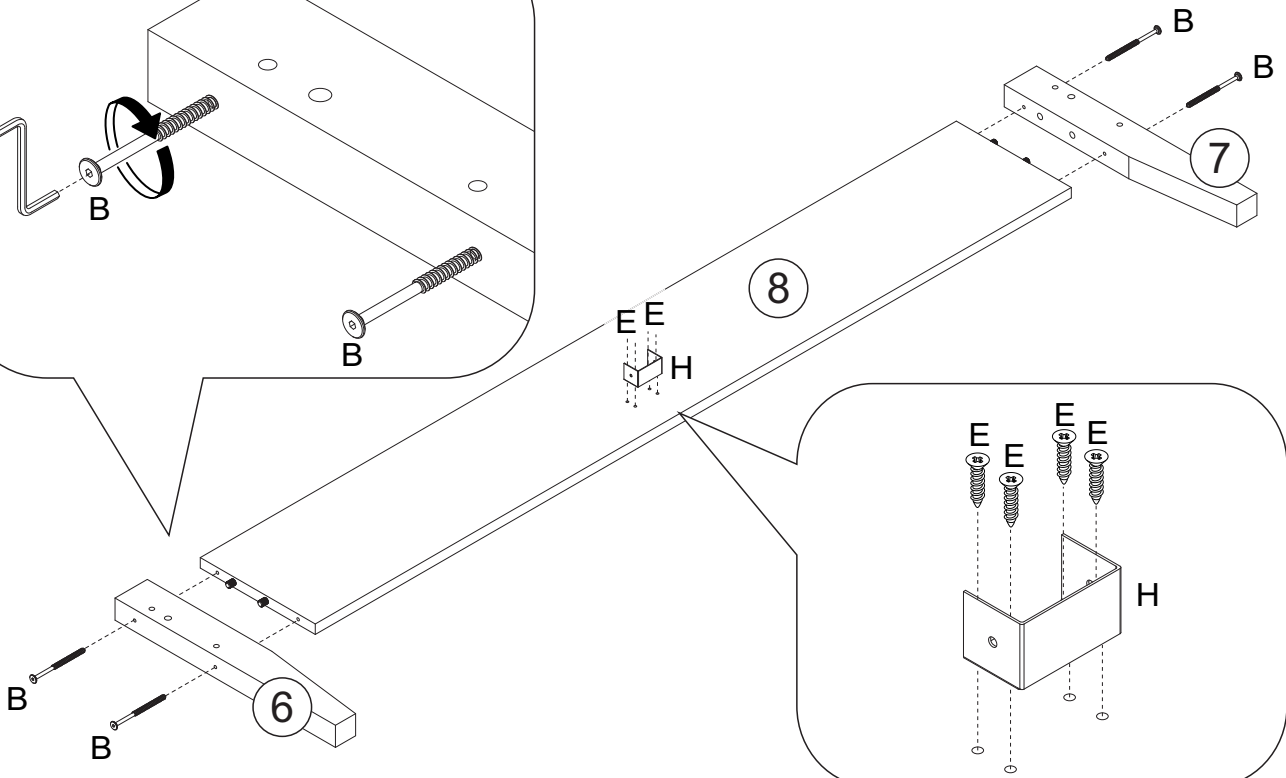
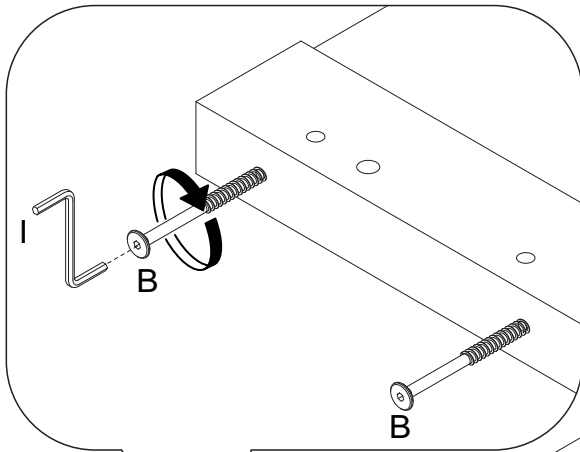

Step 6

Insert barrel nut (G) into pre-drilled holes on rails (9).
Attach rails (9) to headboard (3) using bolt (A).
Bolt (A) will screw into barrel nut (G).

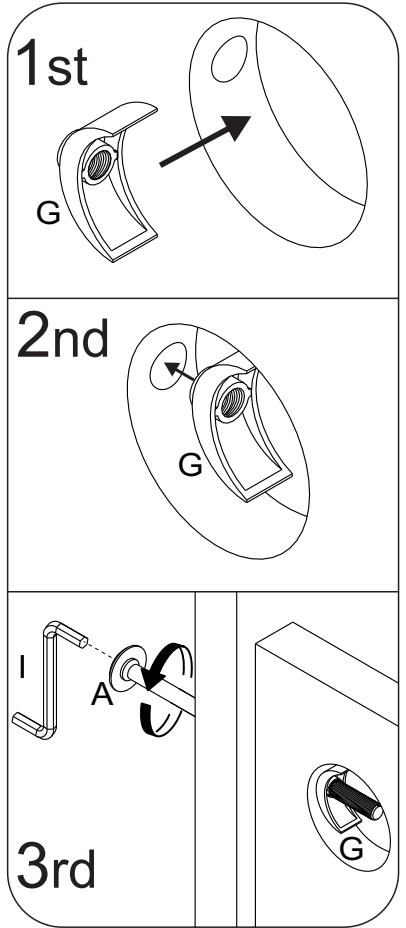
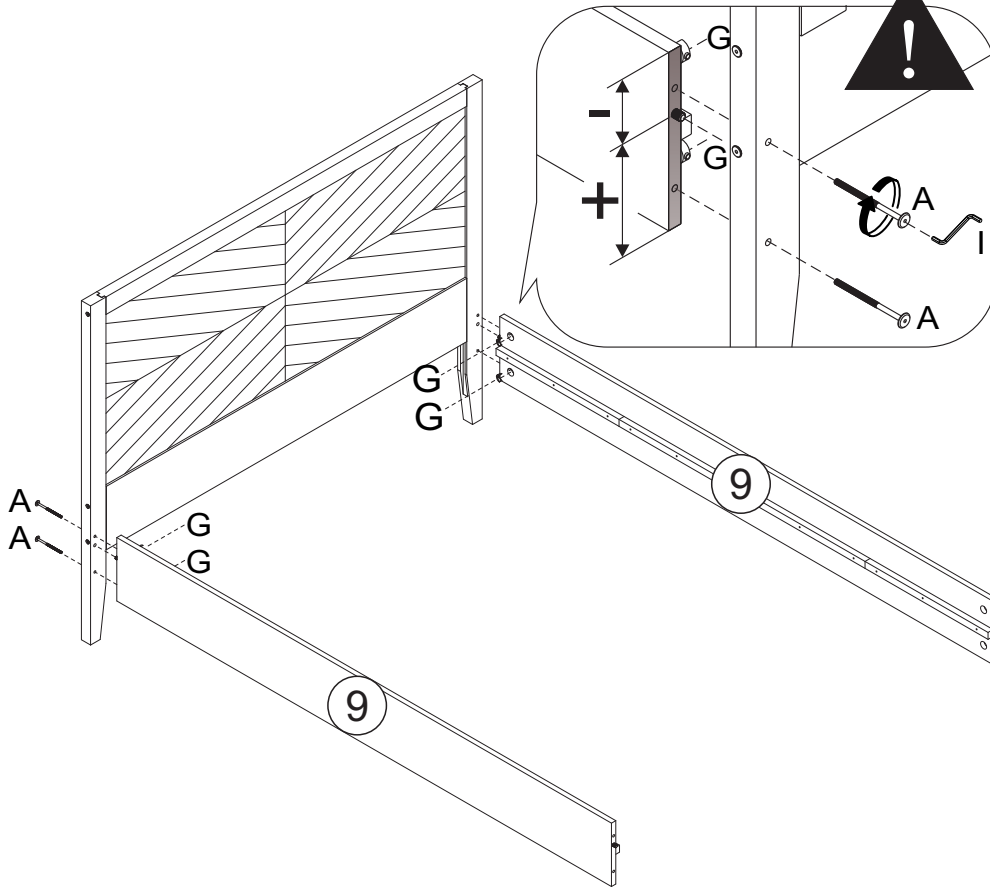

Step 7

Insert barrel nut (G) into pre-drilled holes on rails (9).
Attach rails (9) to legs (6, 7) using bolt (A).
Bolt (A) will screw into barrel nut (G).

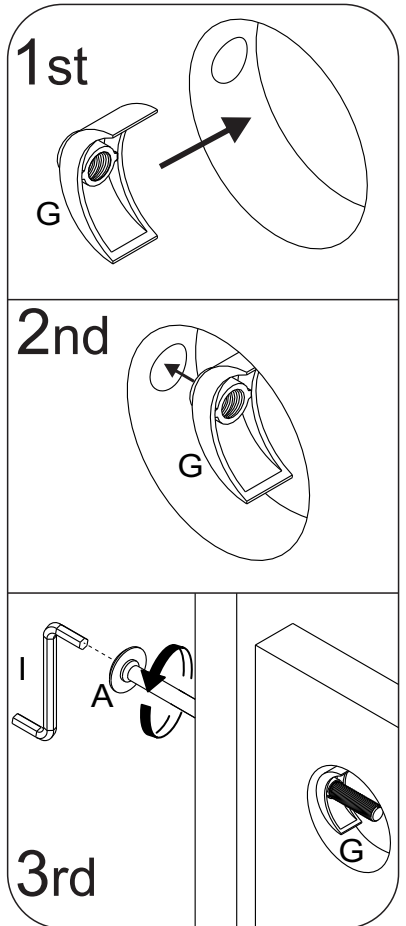
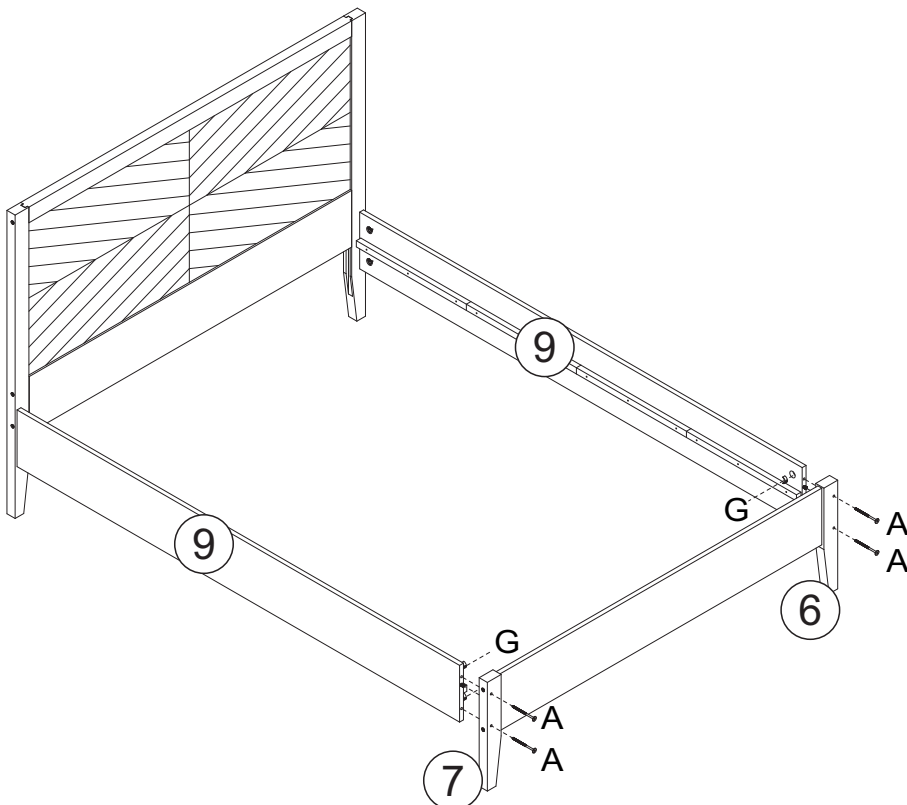

Step 8

Attach slat legs (11) to slat support beam (10) using bolt (C).

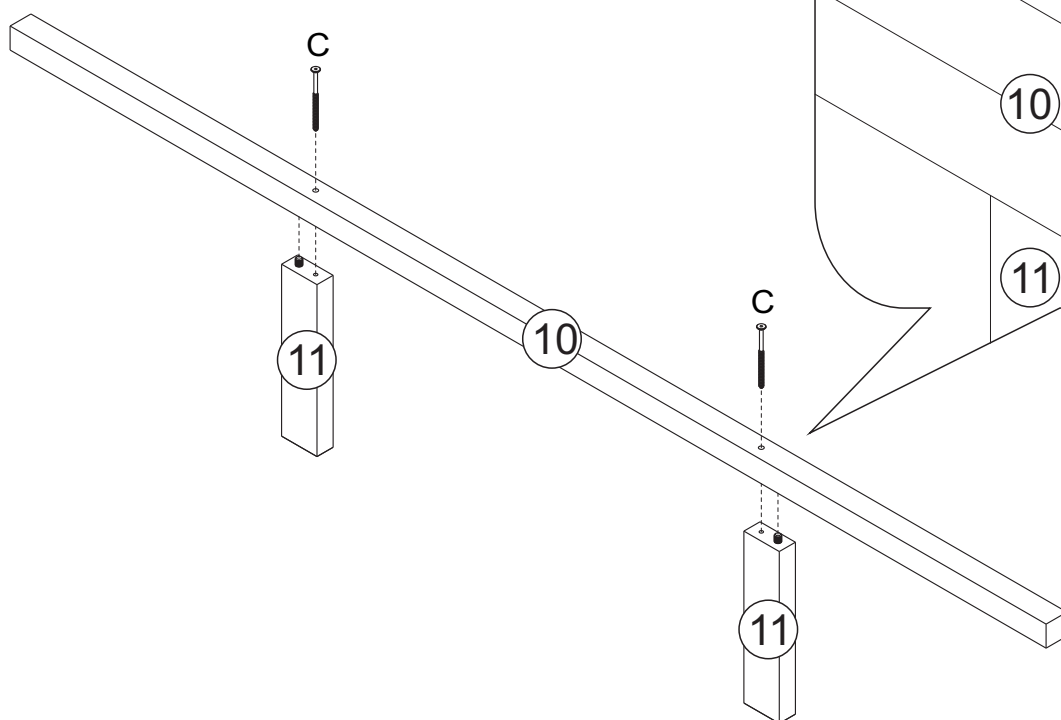

Step 9

Attach slat support beam (10) to bracket (H) using screw (E).

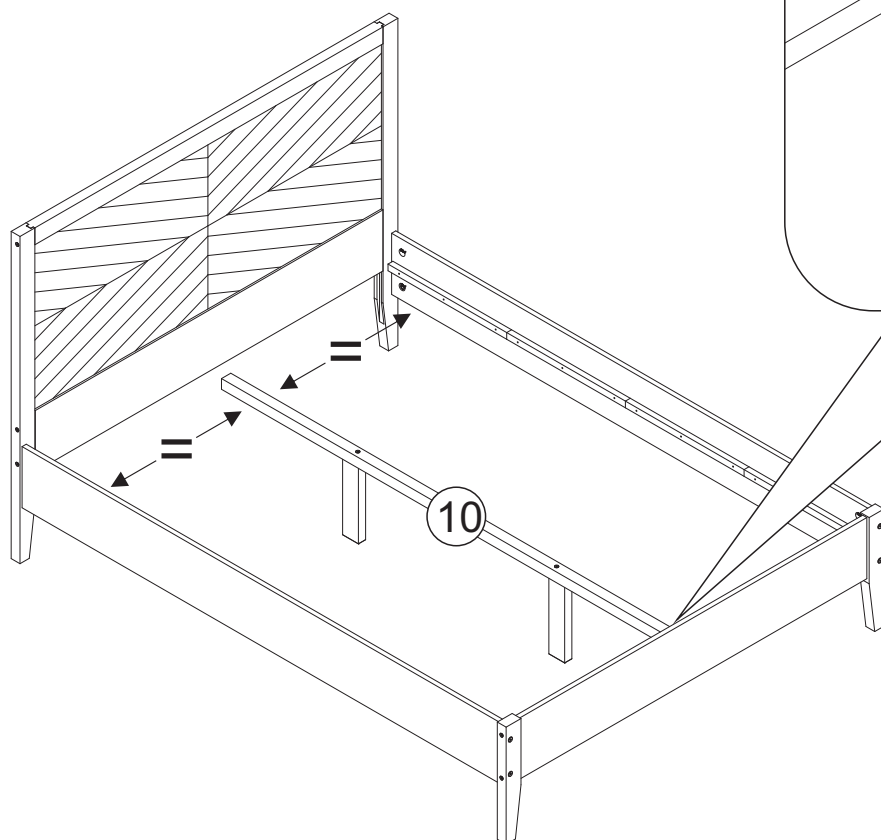

Step 10

Attach slat support (12) to rails (9) and slat support beam (10) using screw (D). Ensure slat are spaced 3 inches from headboard (3).

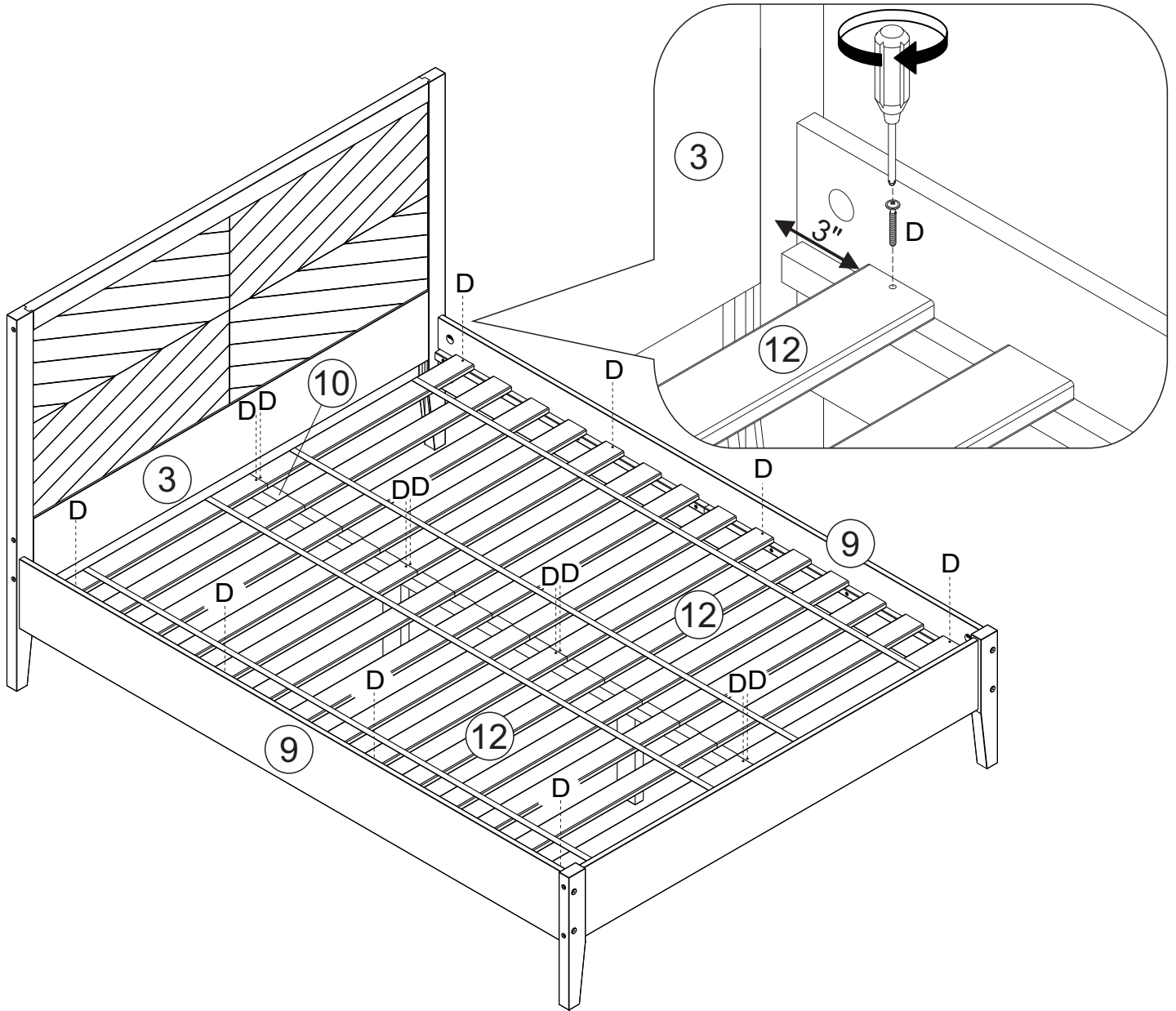

Step 11

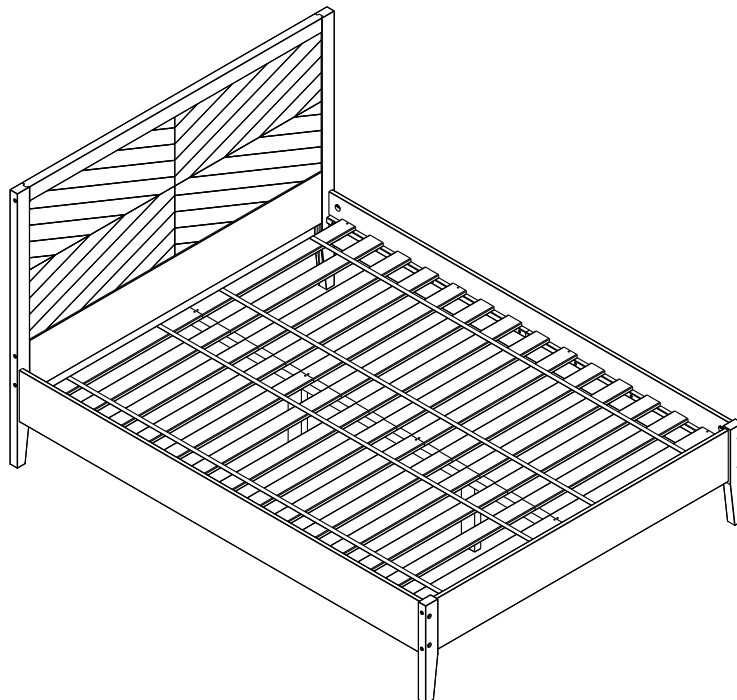

Final Assembly.