

seville classics®

Tilting Mobile Laptop Desk Cart

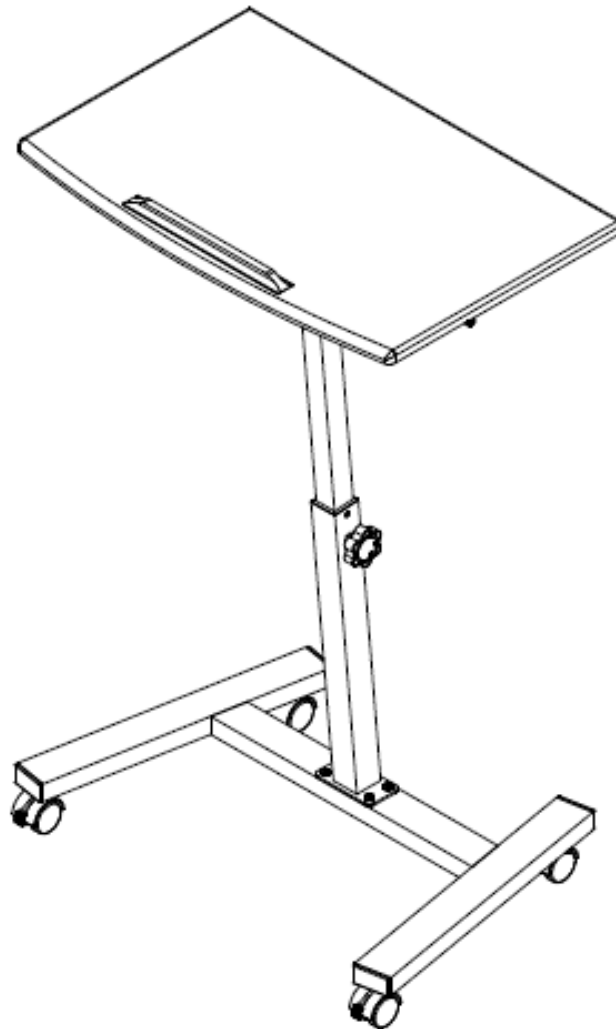

Model #: WEB344, WEB361











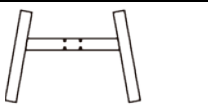
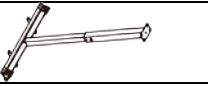

Thank you for choosing Seville Classics! We hope that you enjoy your new desk cart. Please read through this user guide for parts list, assembly instructions, frequently asked questions and further contact information.

Seville Classics
Torrance, CA 90501 USA
www.sevilleclassics.com



WEB162_02232017

Parts List

A. Base	
B. T-bar	
C. Top	
D. Casters (2)	
E. Locking casters (2)	
F. Allen wrench	
G. Tension knob	
H. Top screws (4)	
I. Base screws (4)	
J. Nuts (4)	
K. Washers (4)	
L. 12 mm wrench	
M. 11 mm wrench	

Please make sure you have all the parts on this list.

If you're missing parts, contact us for replacements at (800) 323-5565 or send an email to Support@SevilleClassics.com

Assembly

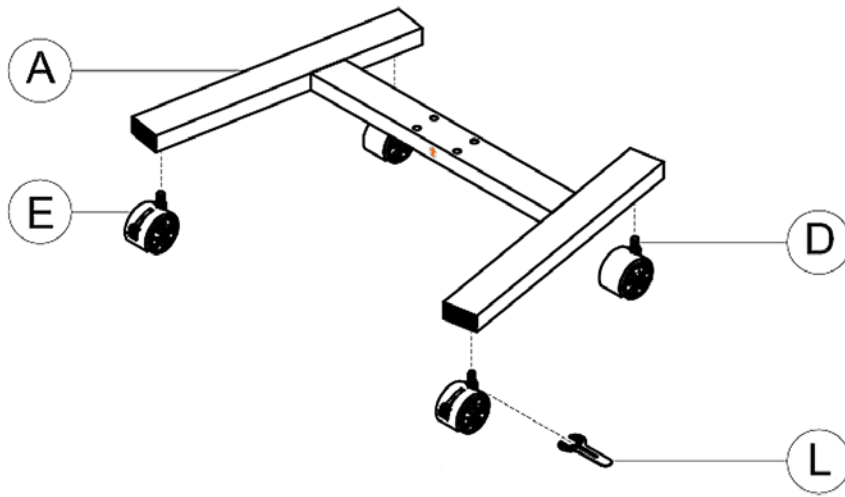

Step 1.

Assemble Base

Tool required: 12 mm wrench (L)

Screw the stem of the casters (D) into the base (A) by hand. Install the locking casters (E) on the open end of the base. Tighten until snug with 12 mm wrench (L).

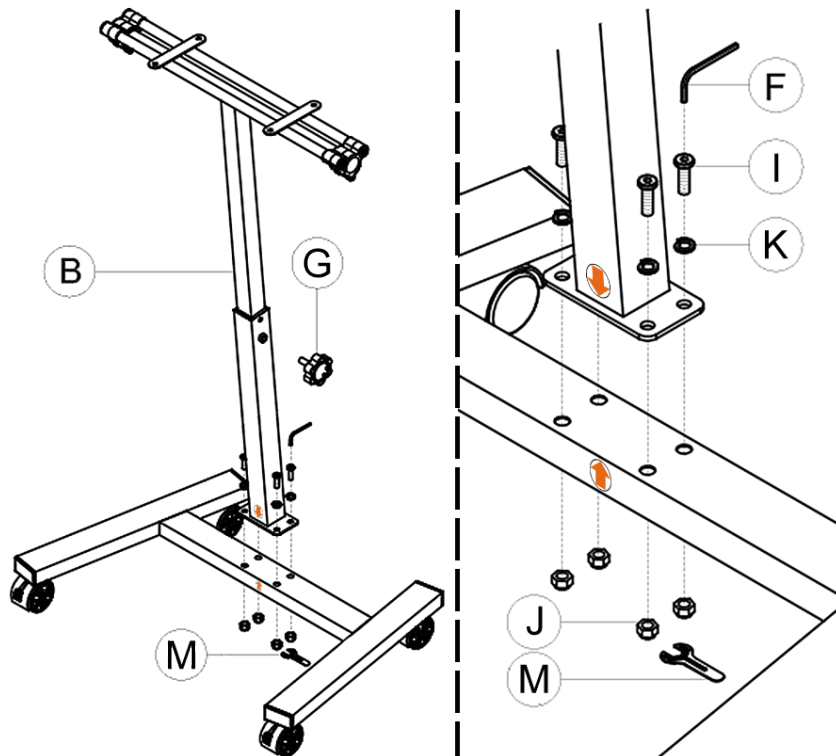

Step 2.

Install T-Bar to Base

Tools required: Allen key (K), 11 mm wrench (M)

Line up the bottom holes on T-bar (B) with the four holes in the center of the base.

IMPORTANT: Align arrows on the T-bar and base. Be sure the hole for the tension knob (G) is on the right side.

Secure the base screws (I) through washers (K) with the Allen key (F), and tighten the nuts (J) with the 11 mm wrench (M).

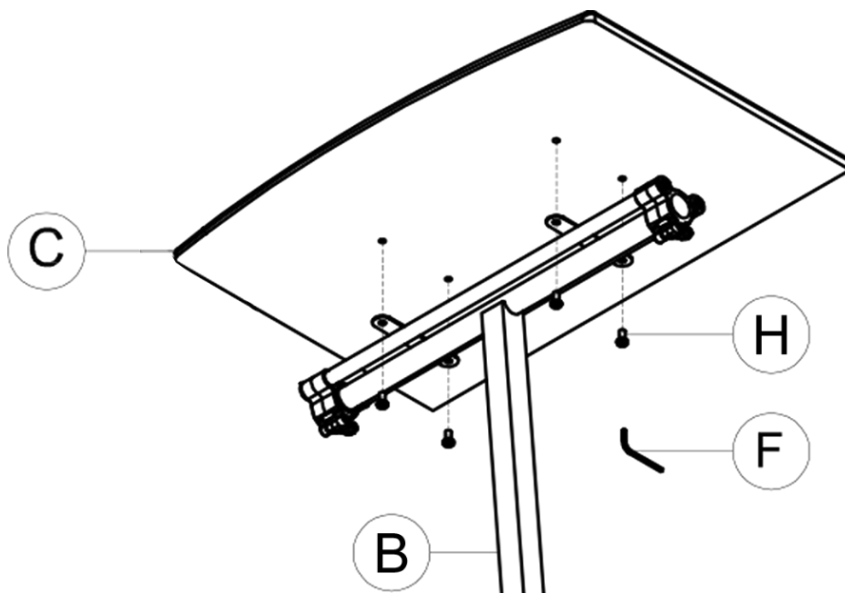

Step 3. Install Top to T-Bar

Tool required: Allen key (K)

Line up the bottom holes on T-bar (B) with the four holes on the back of the top (C) so that the curved side of the desk faces the base opening. Affix top to T-bar with top screws (H) and the Allen key (F).

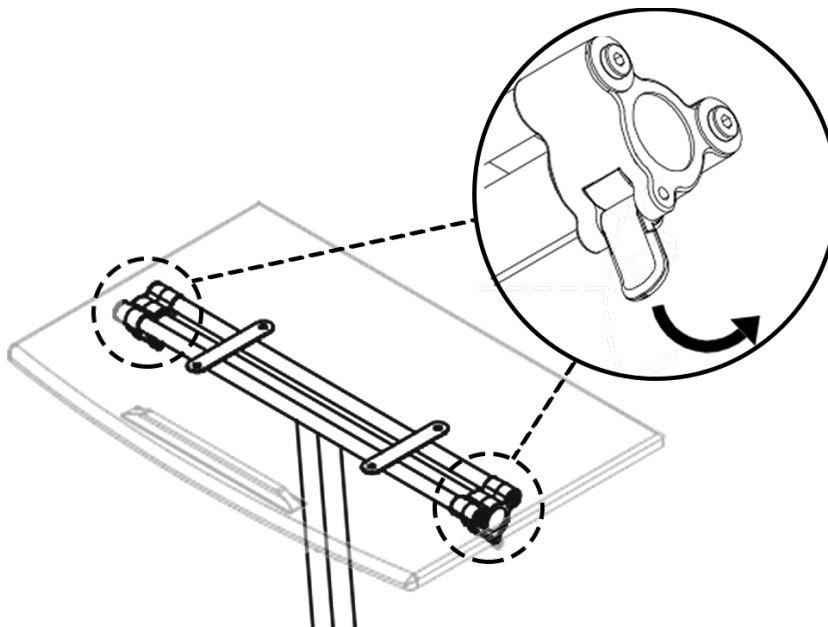

Step 4. Tilt the Top

To adjust the angle of the top, locate the two latches on either side of the T-bar. Pull both latches down towards the floor to unlock the tilt function. Adjust the top to your desired angle. Press up on both latches to lock-in the angle of the top.

**Congratulations
on your new
mobile desk!**

Use Instructions

1. Move desk into desired position and lock casters to prevent movement.
2. Turn the tension knob counter-clockwise to unlock height adjustment.
3. Place hands on both sides of the top and pull up to lift; press down to lower the height.
4. Turn tension knob clockwise until snug to secure the table height.
5. Pull down tabs on both ends of the T-bar to unlock tilting function. Tilt to the desired angle. Press up on tabs at both ends of the T-bar to lock the desk.

FAQs

Q: Why is my table top is slanted?

A. The T-bar mounts to the base at an angle. Make sure it's installed with the tension knob on the right-hand side. The T-bar should be angled toward the wide base opening. If the T-bar is installed correctly, try unlocking the latches and tilting the table to a new angle.

Q: How high and how low can my desk go?

A: Maximum height is 36.4 inches. Minimum height is 23.6 inches.

Q. Can I use it without the wheels?

A. Sure! Leave the wheels off to use directly on the floor. This works best on carpets and near furniture with low floor clearance. Be careful! The base is steel and can scratch floors when used without wheels.

Safety

Do not tip the cart over or place upside down.

Do not place more than 30 lbs. on the desk top.

Customer Service Information

Telephone: (800) 323-5565

Email: Support@SevilleClassics.com

Fax: (310) 533-3899

Homepage: <http://www.SevilleClassics.com>

Hours: 8:30 AM – 4:30 PM (PST)

Seville Classics
Torrance, CA 90501 USA
www.sevilleclassics.com



WEB162_02232017

