

IMPERIUM

CENTRAL VACUUM SYSTEMS. *When only the best will do.*

Owners Manual

TABLE OF CONTENTS

Safety Instructions	Pg. 1-2
Grounding Instructions	Pg. 2-3
Operating Your Central Vacuum	Pg. 4
Installation Tips	Pg. 5
Installation Design	Pg. 5 - 9
Maintenance	
Single Piece Cyclonic Units	Pg. 10
Split Canister Cyclonic Units	Pg. 11
Filter Screens	Pg. 12
Inverted Bag Units	Pg. 13
Paper Bag Units	Pg. 14
Servicing Air Channel	Pg. 15-16
Troubleshooting Guide	Pg. 17-19
Warranty	Pg. 20
Serial Number Location	Pg. 21
Tips on the Care of Your Central Vacuum	Pg. 22

IMPORTANT: Carefully read and retain this booklet.

IMPORTANT SAFETY INSTRUCTIONS

This appliance is for residential or commercial use

When using an electrical appliance, basic precautions should always be followed. Read all instructions before using this appliance.

WARNING: To reduce the risk of fire, electric shock or injury always follow these safety instructions

- Do not leave room when hose is plugged in to the inlet.
- Disconnect power before servicing.
- Electric shock could occur if used on wet surfaces.
- Do not allow to be used as a toy. Close attention is necessary when used by or near children.
- Use only as described in this manual. Use only those attachments that are recommended.
- Do not use with damaged cord or plug. If appliance is not working as it should, has been dropped, damaged, left out doors, or dropped into water, return it to an authorized dealer.
- Do not pull or carry by cord, use cord as a handle, close a door on cord, or pull cord around sharp edges or corners. Do not run appliance over cord. Keep cord away from heated surfaces.
- Do not unplug by pulling on cord. To unplug, grasp the plug, not the cord.
- Do not handle plug, valves or appliance with wet hands.
- Do not unplug system by pulling on vacuum hose. To unplug, grasp the cuff, located on the end of the hose. If you have a standard non-electric hose, pull out with a twisting motion.
- Do not put anything into vacuum inlets or vents. Keep all inlets free of things that might slow airflow, such as lint, dust and hair. Do not use the vacuum system if something is blocking an opening.
- If equipped with an air turbine power brush, unplug the vacuum hose before attaching power brush. Keep fingers, hands and toes away from the base of the power brush. Failure to do so could result in injury from moving parts.
- In the event the power unit should get wet, do not use the vacuum system until it has been properly serviced and examined by a serviceman or installer.
- Keep hair, loose clothing, fingers and all parts of the body away from wand, other openings and moving parts.
- If so equipped, do not use your central vacuum system without dustbag and/or filters in place.
- Always disconnect vacuum system before emptying dirt canister, cleaning filters or replacing dustbag.
- Use extra care when cleaning on stairs.
- Do not use to pick up flammable or combustible liquids such as gasoline or use in areas where such liquids may be present.
- Do not use to pick up dry wall or cement dust. Doing so will void warranty.
- Do not pick up anything that is burning or smoking, such as cigarettes, matches or hot ashes.
- When finished put the vacuum hose and attachments away to prevent tripping accidents.

- For a grounded appliance, connect to a properly grounded outlet only. See grounding instructions.
- Do not handle electric hose or inlets with wet hands.
- If your system is equipped with an electrical vacuum hose, do not use if damaged. Do not pull hose around sharp corners, and keep hose away from heated services. Do not run other appliances over vacuum hose.
- Do not use the electric vacuum hose if it is damaged, cut or punctured. Do not pick up sharp objects with the vacuum nozzle or hose. Hose may contain electrical wires.
- For electric vacuum hose, connect to a properly wired 2-pole polarized outlet.
- Electric vacuum hose, use only with the electric power brush for use with the central vacuum system.
- The extension cord provided may only be used with the electric power brush for use with the central vacuum system.
- **DO NOT USE** the electric vacuum hose or extension cord with any appliance other than the central vacuum electric power brush for which it is intended.

CAUTION: Do not use when rug (or floor) is wet.
ATTENTION: Ne pas utiliser lorsque le tapis (ou le plancher) est mouillé.

SAVE THESE INSTRUCTIONS

-WARNING-
ELECTRIC SHOCK COULD OCCUR IF USED ON WET SURFACES

GROUNDING INSTRUCTIONS

FOR CORD CONNECTED APPLIANCE

This appliance must be grounded. If it should malfunction or breakdown, grounding provides a path of least resistance for electric current to reduce the risk of electric shock. Your central vacuum system is supplied with an electrical cord having a grounding pin. It is recommended that this plug be used only with an appropriate outlet that is properly installed and grounded in accordance with all local codes and

ordinances. This appliance is for use on a nominal 120-volt circuit (U.S. only) or 230/250 volt circuits where applicable, and has a grounded plug that looks like the plug shown in Figure A. A temporary adapter, that looks like the adapter illustrated in Figure B, may be used to connect this plug to a 2-pole receptacle as shown in Figure B if a properly grounded outlet is not available.

The temporary adapter should be used only until a properly grounded outlet (Figure A) can be installed by a qualified electrician. **NOTE: Temporary adapters are not permitted in Canada.** The green colored rigid ear, lug or the like, extending from the adapter, must be connected to a permanent ground such as a properly grounded outlet box cover. Whenever the adapter is used, it must be held in place by a metal screw.

DANGER- Improper connection of the equipment - grounding conductor can result in a risk of electric shock. Check with a qualified electrician or your installer if you are in doubt as to whether the outlet is properly grounded. Do not modify the plug provided with the appliance - if it will not fit the outlet use a temporary adaptor as shown and have a proper outlet installed by a qualified electrician as soon as possible.

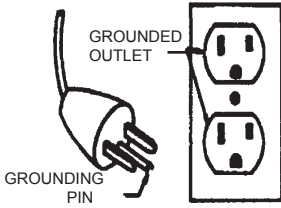

FIGURE A

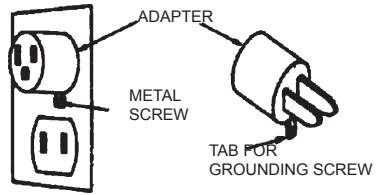

FIGURE B

Imperium 220/230 Volt unit requires 6-20 R Receptical.



GROUNDING INSTRUCTIONS

FOR PERMANENTLY CONNECTED APPLIANCE

This appliance must be connected to a grounded metal, permanent wiring system; or an equipment-grounding conductor must be run with the circuit conductors and connected to the equipment-grounding terminal or lead on the appliance.

OPTIONAL EQUIPMENT

FOR ELECTRIC HOSE OR VACUUM HOSE USED WITH EXTENSION CORD

This appliance must be connected to a polarized (2-pole receptacle), permanent wiring system.

RECEIVER BOX FOR REMOTE CONTROL

This receiver box must be directly plugged into a polarized (2-pole receptacle) permanent wiring system. Do not use an adapter.

DANGER ---Do not use the receiver box for any other purpose except for use with the intended central vacuum system, 24 volt remote control system. Any other use may cause malfunction or breakdown of the receiver box.

OPERATING YOUR CENTRAL VACUUM

Your central vacuum system has been engineered for a long, trouble-free service life. Your power unit is covered by a factory limited warranty that is enclosed with these instructions. Please read your limited warranty carefully and return the warranty card. It is important that you fill out your warranty registration card properly and mail it to the factory. You should fill out your registration card within ten (10) days of installation and mail it to **Central Vacuum Stores, 11236 47th St N Clearwater, FL 33762**. Remember, your warranty does not cover abuse or misuse of the equipment.

CLEANING TOOLS - Since there are several tool kits available, the use and care of these tools is explained in a separate booklet packed with each of the tool kits. It is very important to utilize the tool that is designed to perform a particular cleaning job, in order to obtain full efficiency from your system. Each of the tools and their designed use is explained in the booklet packed with your particular tool kit. Also, other special carpet & flooring tools are available, which are not included as part of the normal tool kits. A few of these are a vibrating upholstery tool, a pet grooming tool, and a hand held air turbine. In addition, there are accessories designed to allow you to safely pick up liquids with your cleaning system such as the Wet Pick-Up. Each of these tools is available for purchase from Central Vacuum Stores; if you would like to know more about a certain tool, please contact them.

VACUUM INLETS - When opening the door of the vacuum inlet valve to insert the cleaning hose, care should be taken not to distort the door by forcing it too far open. Do not turn the system

on and try to open the door of another inlet, since this will tend to pull the rubber gasket from the door. If inlet does not have remote on/off hose activated, leave door open for a few seconds after removing hose from inlet so the cyclonic filtration has time to shut down and debris can settle back down into the dirt can. If the power unit continues to run after the hose is removed from the inlet, the small ball which activates the low voltage switch at the inlet should be checked to make sure it has not become lodged in some way. Should this not shut the unit off, disconnect the electrical supply to the power unit and notify your local dealer or serviceman.

VACUUM POWER UNIT - Your power unit does not require any oil. The bearings in the motor are greased and sealed for life. The motor of the unit has contact brushes inside. As the unit is used, the brushes will wear, even when functioning properly. Because of this, the brushes in most power units will need to be replaced after 700 to 1,500 hours of use. Brush life is also affected by humidity, altitude, temperature and the number of starts and stops. So, there is a wide spread in the actual life of the motor brushes. On average the life of the motor brush, when used in a normal manner, will be from ten to twenty years. The cost of replacing your motor brushes is not great; but, the damage that can be done to the motor through not replacing the brushes **before they are completely worn out** is considerable. We recommend that you have your unit and motor brushes inspected by a qualified serviceman every 4-6 years.

THANK YOU FOR CHOOSING AN IMPERIUM PRODUCT.

Installation Tips

Mounting Bracket

All Imperium central vacuum units have the same mounting bracket. It is attached to the unit for shipping and then must be removed for installation to the wall.

Still need help? Call 1-800-221-8227.

1 Remove the small piece of metal on the side of the mounting bracket and discard.



3 Continue to tap with a mallet until the mounting bracket is completely removed.



2 To remove the mounting bracket, tap lightly with a mallet. The mounting bracket will slide down.

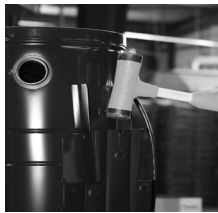

4 Attach the removed bracket to the wall and slide the unit onto the bracket.



Utility Valve Installation

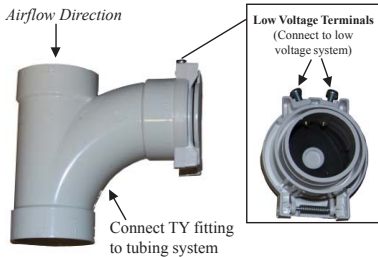

Low Voltage Wire Connections

Strip the wire, press the Quick Clips to the right and insert the wire into the holes.



Proper placement of protector plate (for paper bag models only)

Protector plate must be installed properly for the vacuum to work



Protector Plate

Make sure the Protector Plate is in place. This is necessary for proper suction.

Upon receiving your vacuum system, lift off the lid. The protector plate should be located inside the can just below the bag.

The protector plate is installed correctly when it lays flat, prong side down, directly under the bag. The warning label should be facing up. The plate provides a barrier between the bag and mesh screen. This allows air to circulate preventing the motor from overheating.



Do not to throw this part away.

Typical Installation Design of Paper Bag Units - CV260, CV280, CV300, CV800

Hanger Bracket Suggested Guidelines

48" from floor
to top hole of
can bracket



48"

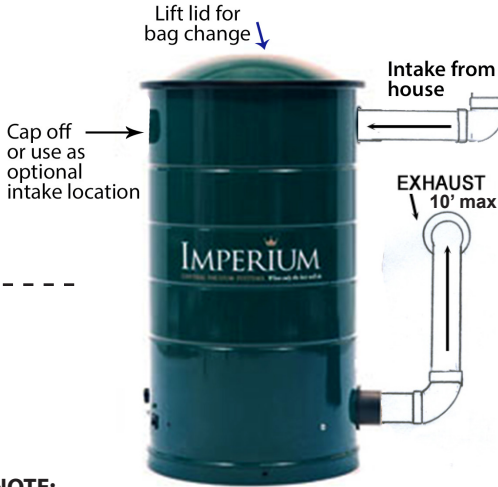

***Note:** Ensure bag protector plate is in proper place and screen underneath bag plate is clear of debris.
See page 5 for more details.

NOTE:

* Power unit must be mounted at least 6 inches from sidewall, floor & ceiling.

Typical Installation Design of Filtered Units - CV3200, CV3400, CV3800

Hanger Bracket Suggested Guidelines

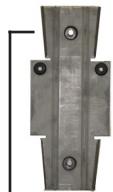

48"

48" from floor
to top hole of
can bracket



NOTE:

* Power unit must be mounted at least 6 inches from sidewall, floor & ceiling.

Typical Installation Design of Split Canister Units - CV7800

Hanger Bracket Suggested Guidelines



32" between top dirt can bracket hole & top motor unit bracket hole



48" from floor to top hole of dirt can bracket

NOTE:
* Motor unit must be mounted at least 6 inches from sidewall, floor & ceiling.

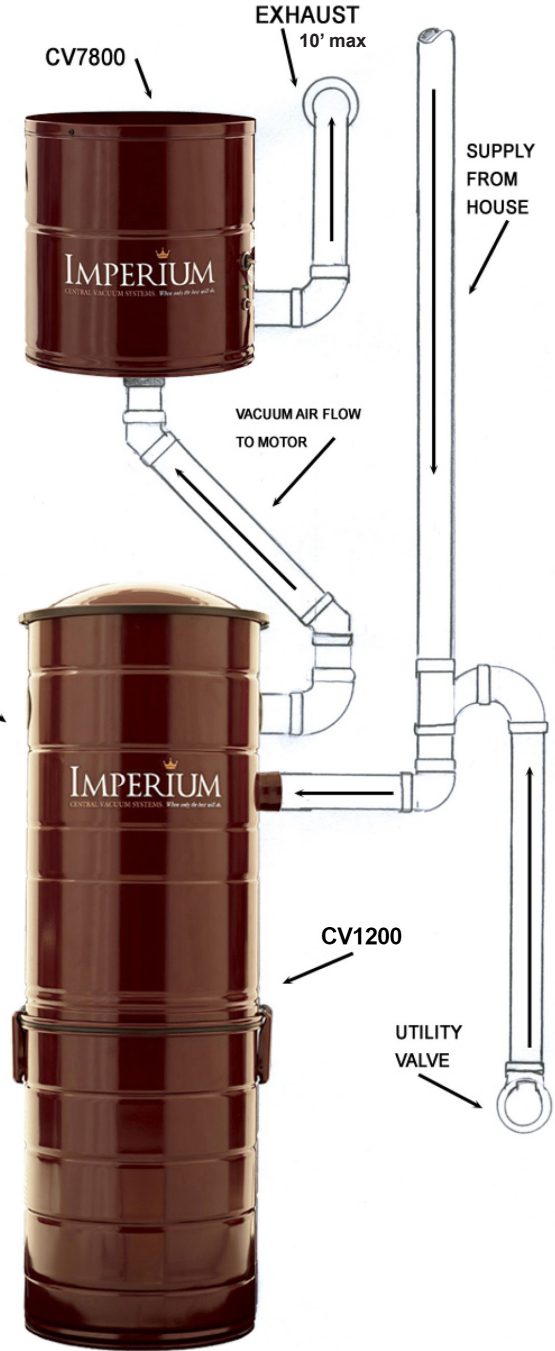

Typical Installation Design of Split Canister Units CV9000/CV15400 - Option 1

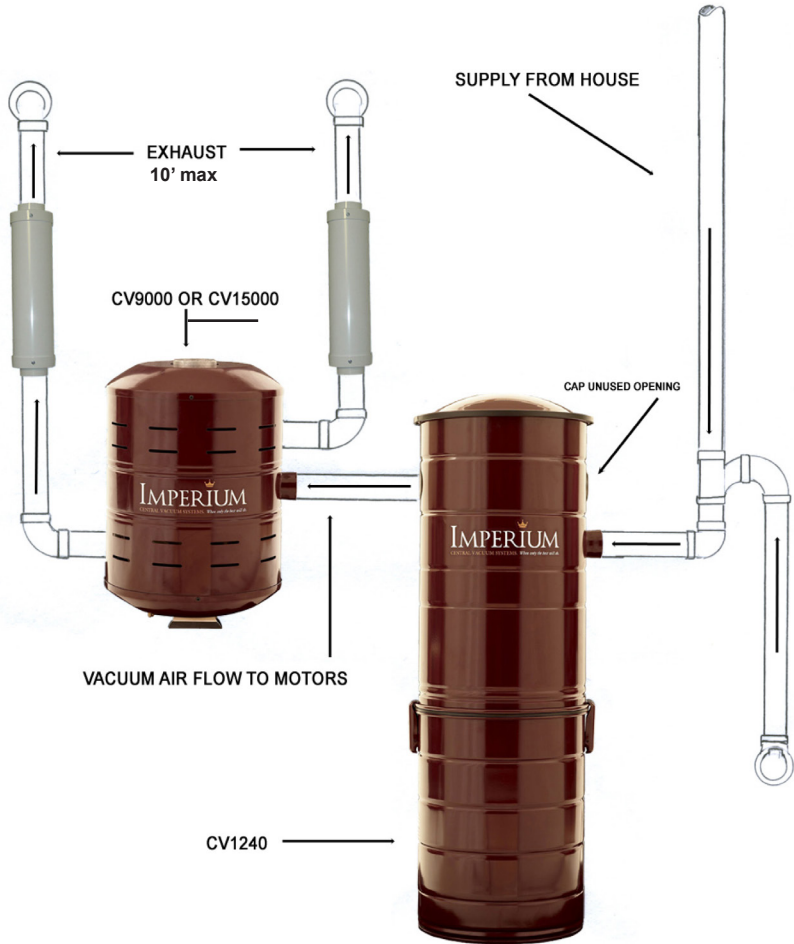

Hanger Bracket Suggested Guidelines

NOTE:

* Motor unit must be mounted at least 6 inches from sidewall, floor & ceiling.



48" from floor to top hole of motor can bracket

48"

48" from floor to top hole of dirt can bracket

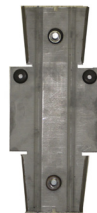

Typical Installation Design of Split Canister Units CV9000/CV15400 - Option 2

Hanger Bracket Suggested Guidelines



36" between top dirt can bracket hole & top motor unit bracket hole

36"



48" from floor to top hole of dirt can bracket

48"

NOTE:

* Motor unit must be mounted at least 6" from sidewall, floor & ceiling.

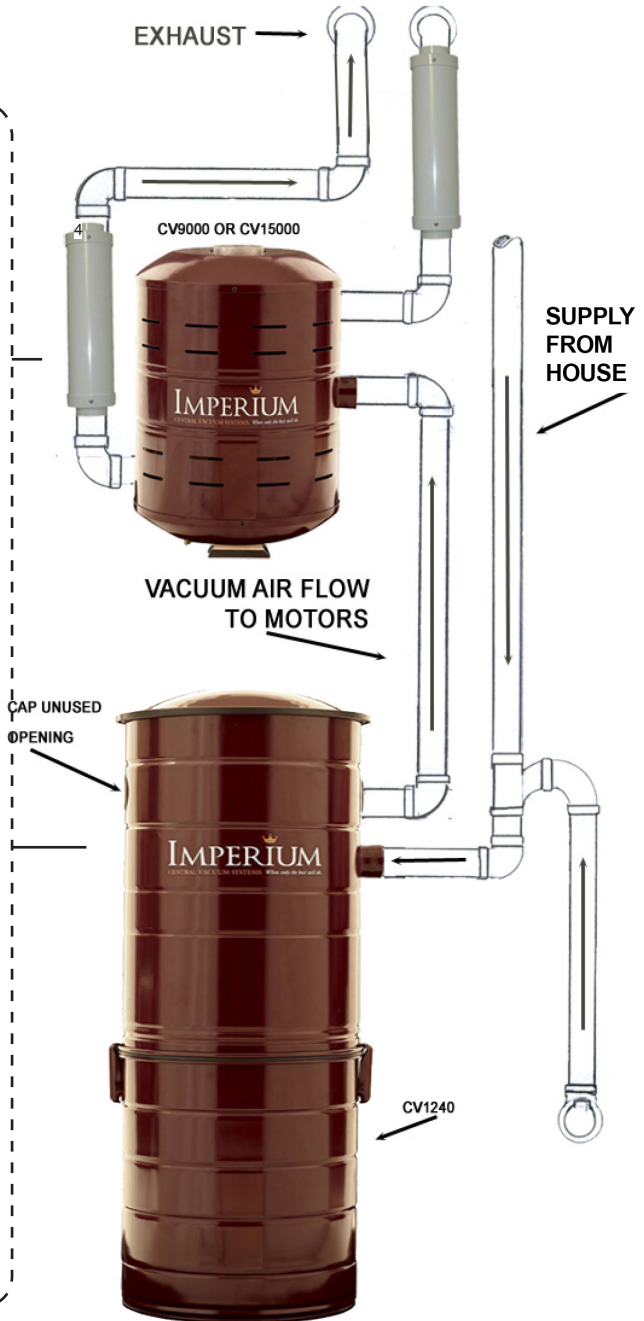

MAINTENANCE - Cyclonic Single Piece Systems

The mass of dirt and debris picked up by your central vacuum system is deposited in the dirt canister, which is attached to the bottom of your power unit on single canister units or filter canister if split system unit and will need to be emptied periodically.

To Empty the Canister

- 1 Remove the dirt canister by supporting bottom of the canister with your knee* (Fig. 1), then unsnap the two latches by grasping the lower end of each latch and pulling straight away from the canister.
Note: The latches may be tight, but do not try to adjust them. They need to latch tightly to ensure a proper seal, which is vital for proper cyclonic operation.
- 2 Carefully lower the dirt canister and empty the debris into any suitable trash container. (If equipped with Air Channel and plastic can liner, see page 14 & 15)

Check the screen

- 3 Check the protection screen by looking up or feeling up inside the dirt canister to remove any debris that may have become stuck on the screen up inside the metal cone.
- 4 A plastic bag may be placed over the bottom portion of the top canister. While holding the plastic bag tightly around the can with one hand, push the bag up inside with the other hand and brush the screen surface (Fig. 2). This way, the screen can be cleaned without getting dust or debris on the floor or hands.

Reattach the dirt canister

- 5 Replace the dirt canister by slipping the rim of the dirt can over the lip of the top can until it is seated against the rim gasket.
- 6 Then while holding the canister in place with your knee* (see Fig. 1), fasten the two latches. Do this by hooking the top lip of each latch over the rim of the top can and then press straight in on the bottom of the latches until they lock.



If you notice a lack of suction or power, safety screen may be blocked. Remove lid and clean.

TIP: When cleaning the screen up inside the can, try using a toilet bowl brush or something similar. This will allow you to reach up inside more easily than just by using your arm. Still use the plastic bag, as this will keep the dirt from falling on you or your floor.

*If you have trouble removing or replacing the dirt canister using your knee, try supporting the can with one hand, unlatching (or relatching) one side with the other hand. Then, reverse your hands to unlatch (or relatch) the other side.

MAINTENANCE - Split Canister System

This system includes a power unit and a separate dirt canister that are mounted independently of each other. The dirt canister has the removable bottom can.

Emptying your Dirt Can

To remove accumulation, follow these steps:

- 1 Remove the dirt canister by supporting bottom of the canister with your knee* (Fig. 1), then unsnap the two latches by grasping the lower end of each latch and pulling straight away from the canister.

Note: The latches may be tight, but do not try to adjust them. They need to latch tightly to ensure a proper seal & optimum cyclonic operation.

- 2 Carefully lower the dirt canister and empty the debris into any suitable trash container. (If equipped with plastic can liner, see page 15)

Cleaning the Lint Screen

For split system units there is an additional screen that must be cleaned regularly to ensure proper suction and operation.

- 3 Lift top can lid off of the dirt canister.
- 4 Use your hand to wipe it clean and dispose of debris or pull out the screen and shake it off.
- 5 *Optional maintenance:* The underneath of the screen can also be cleaned. To do so, remove the two screws, lift screen and wipe the underneath of the screen clean. Place screen back into unit and secure with the two screws.
- 6 Place lid back on top of can. Be sure it is placed squarely on the top of the canister to prevent a vacuum leak.

Reattaching the Dirt Canister

- 7 Replace the dirt canister by slipping the rim of the dirt can over the lip of the top can until it is seated against the rim gasket.
- 8 Then while holding the canister in place with your knee* (see Fig. 1), fasten the two latches. Do this by hooking the top lip of each latch over the rim of the top can and then press straight in on the bottom of the latches until they lock.

*If you have trouble removing or replacing the dirt canister using your knee, try supporting the can with one hand, unlatching (or relatching) one side with the other hand. Then, reverse your hands to unlatch (or relatch) the other side.

Continued of next page.



If you notice a lack of suction or power, lint screen may be blocked. Remove lid and clean.

? See next page for instructions:

HOW OFTEN SHOULD I CHECK OR EMPTY MY DIRT CANISTER?



HOW OFTEN SHOULD I CHECK OR EMPTY MY DIRT CANISTER?

Initially, the dirt canister should be checked or emptied weekly until some idea can be obtained as to how long it takes to half fill the canister under your normal cleaning routine. All vacuum systems will function more effectively if the dirt can is emptied frequently. Under no circumstances should you allow your dirt canister to become more than 3/4 full before emptying.

Note: The canister will fill more rapidly if NEW carpets are being cleaned for there is usually a tremendous quantity of loose fibers that are retained in the carpet from the manufacturing process. In some instances it may take several months before all of these loose fibers are removed.

SERVICING FILTER SCREENS ON DIRT CANS

Servicing the Fine Mesh Filter Screen - STANDARD

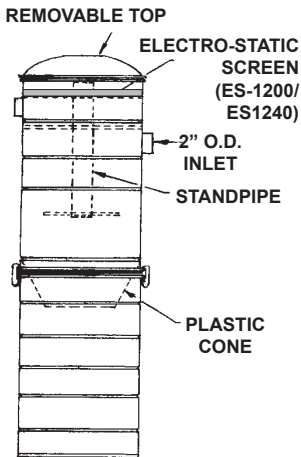

A: To remove the Fine Mesh Screen (FSF12/FSF14):

Remove the lid from the canister, then lift the screen up over the stand pipe.

B: To Clean:

The Fine Mesh Filter Screen can best be cleaned by tapping or brushing off the screen.

C: To replace the Fine Mesh Filter Screen (FSF12/FSF14):

Place the screen over the standpipe - push down to insure it seats on the metal screen. Replace the lid and operate normally.

Servicing the ELECTRO-STATIC Screen - OPTIONAL

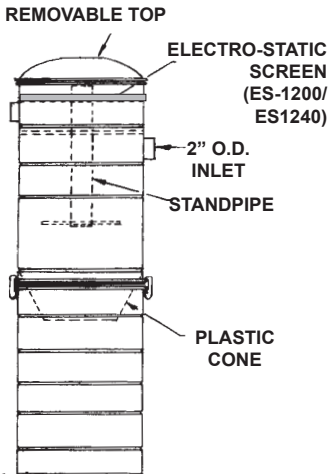

A: To remove the ELECTRO-STATIC Screen (ES-1200/ES1240):

Remove the lid from the canister, then lift the screen up over the stand pipe.

B: To Clean:

The ELECTRO-STATIC Screen can best be cleaned by vacuuming, tap water rinsing, or dousing in an ordinary detergent solution. **NOTE: Before replacing the ELECTRO-STATIC Screen, be sure it is dry.**

C: To replace the ELECTRO-STATIC Screen (ES-1200/ES1240):

Place the screen over the standpipe - push down to insure it seats on the metal screen. Replace the lid and operate normally.

MAINTENANCE - Inverted Bag

Inverted bag units provide a permanent filter and require occasional cleaning. To clean the inverted bag units, follow these steps:

Emptying your Dirt Can

To remove accumulation, follow these steps:

- 1 Remove the dirt canister by supporting the bottom canister with your knee*. Then, unsnap the two dirt canister latches by grasping the lower end of each latch and pulling straight away from the canister (Fig 1).
- 2 Carefully lower the dirt canister, dump the contents into trash container (Fig 2), & set aside.



Cleaning the Inverted Bag

Not necessary to remove the inverted bag just follow these steps:

- 3 A plastic bag may be placed over the bottom portion of the top canister. Then, while holding the plastic bag tightly around the canister with one hand, push the bag up inside with the other hand, and brush/shake the bag surface to loosen any dust and debris that may have accumulated on the bag (Fig 3). In this way, the bag can be cleaned without getting any dust or debris on the floor or hands.



- 4 Replace the dirt canister by slipping the rim of the dirt canister over the lip of the top can until it is seated against the rim gasket. Then while holding the canister in place with your knee* (Fig 1) fasten the two latches. Do this by hooking top lip of each latch over the rim of the top can & then press straight in on the bottom of latches until they lock.



*If you have trouble removing or replacing the dirt canister using your knee, try supporting the can with one hand, unlatching (or relatching) one side with the other hand. Then, reverse your hands to unlatch (or relatch) the other side.



HOW OFTEN SHOULD I CHECK OR EMPTY THE PAPER BAG?

Initially, the dirt canister should be checked or emptied weekly until some idea can be obtained as to how long it takes to half fill the canister under your normal cleaning routine. All vacuum systems will function more effectively if it is emptied frequently. Under no circumstances should you allow your dirt canister to become more than 3/4 full before emptying. (Note: The canister will fill more rapidly if NEW carpets are being cleaned for there is usually a tremendous quantity of loose fibers that are retained in the carpet from the manufacturing process. In some instances it may take several months before all of these loose fibers are removed.)

HOW OFTEN SHOULD I CLEAN THE INVERTED BAG?

The inverted bag should be cleaned approximately 3-4 times a year or every time the dirt canister is dumped. If your inverted bag should ever need replaced, contact your local dealer.

MAINTENANCE - Paper Bag

This system uses a sealed paper bag for filtration. The mass of dirt and debris is picked up by your vacuum and deposited into the filter bag inside your dirt canister. Bag #: HPB1 & HPB2H

Emptying your Dirt Can

To remove accumulation, follow these steps:

- 1 Remove the lid by lifting straight up. There are no hinges or clamps.
- 2 Remove the bag by sliding the rubber gasket that surrounds the hole in the paper bag off the plastic inlet stem that protrudes through the front of the canister.
- 3 Once the bag is off of the inlet stem, seal the bag by removing the backing from the tab and cover the hole with the flap. Press the flap so that it securely seals over the hole (Fig. 3). This will help prevent dirt and dust from escaping. Now, lift the paper bag from the dirt canister and place in a suitable trash container.

Installing a New Bag

- 4 Take a new bag and extend it fully (Fig. 4).
- 5 Place it in the canister, and slide its rubber gasket onto the inlet stem until the rubber gasket drops into place in the ridge that is around the inlet stem (Fig. 5).
- 6 Carefully replace the lid onto the dirt canister to ensure that it seals properly. Not doing so could cause a vacuum leak and reduce the cleaning efficiency of your system.

If bag breaks...

In the event of a bag breaking while in the unit, it is necessary to lift the plate located under the bag and clean the small screen.

1



3



4



5



Some units come equipped with an internal thermal switch. When tripped it requires up to 10 (ten) minutes to reset before using again.



HOW OFTEN SHOULD I CHECK OR EMPTY THE PAPER BAG?

The filter bag should be changed or cleaned when there is 3-6 inches of dirt or anytime there is a noticeable reduction of air flow at the cleaning tool.

Initially, the dirt canister should be checked or emptied weekly until some idea can be obtained as to how long it takes to half fill the canister under your normal cleaning routine. All vacuum systems will function more effectively if they are emptied frequently. Under no circumstances should you allow your dirt canister to become more than 3/4 full before emptying.

SERVICING YOUR DIRT CAN WITH AIR CHANNEL

1 Place knee under bottom dirt canister to support the weight of the can, while you unlatch it.



2 Set the dirt can on the floor.



3 Remove edge of the plastic bag from the bag clip.



4 Lift the plastic bag from the dirt can.



5 When plastic bag is high enough, wrap up the open end of the bag for a mess-free disposal.



SOME MODELS: WITH SEPARATE DIRT CANISTER ONLY

6 Lift up the top lid.



7 Clean debris from top screen as you would a dryer lint screen by wiping debris off of screen and deposit debris into used plastic bag.



8 Throw away the used plastic bag.



9 Lift dirt can back to the bottom of the dirt canister. Use your knee to support the can as you re-latch it.



Note: Do not store your replacement plastic bags on top of your central vacuum system. This can cause severe damage to your central vacuum system by not allowing the motor to get cool clean air.

INSTALLATION OF NEW PLASTIC BAG

1 Place a clean plastic bag into the dirt can.



2 Wrap the edges of the plastic bag around the edge of the dirt can.



3 Place the portion of the plastic bag around the Air Channel under the bag clip.

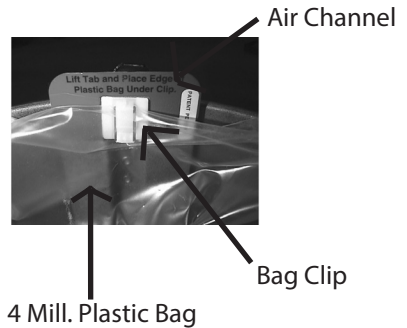

4 Use your hands and press the plastic bag up against the sides of the dirt can.



TROUBLESHOOTING GUIDE

Please read the Warranty certificate before attempting any service on your power unit. The motor in your power unit **DOES NOT** require oiling. The bearings have been lubricated and sealed at the factory. Tampering in any way with the motor blower will invalidate your warranty. Your central vacuum system has been engineered to provide many years of carefree service. Should your system for some reason fail to function properly, the following chart and instructions should help you to restore efficient service promptly. Check the chart for symptoms and then read across to determine the probable cause. The probable causes are numbered for your convenience and after you have found your symptom, refer to the directions for checking that item.

SYMPTOM					Check each X for PROBABLE CAUSE
NO AIRFLOW	LOW AIRFLOW	POWER UNIT DOES NOT RUN	POWER UNIT CONTINUES TO RUN	CYCLES OFF AND ON	
X		X		X	1. Power Cord
X		X			2. Push-to-reset Circuit Breaker on Unit
X		X			3. Circuit Breaker in House Panel
		X			4. Internal Thermal Switch in Unit <small>(some models)</small>
X		X		X	5. Electrical Wall Outlet Plug
		X			6. Switch in the Wall Inlet Stuck Off
			X		7. Switch in Wall Inlet Stuck On
X		X		X	8. Remote Control Wire Broken
			X	X	9. Remote Control Wire - Shorted
X	X				10. Flexible Hose Plugged
X	X				11. Tubing in Walls Clogged
	X				12. Dirt Canister Overfilled
	X				13. Filter Bag - Clogged (some models)
X					14. Dirt Canister Lid - Off
	X				15. Dirt Canister Gasket Loose
X	X				16. Outside Exhaust Blocked
	X				17. Dirt Canister Not Latched
	X				18. Another Wall Inlet Door Open
X	X				19. Blower Protection Screen Clogged
			X		20. Relay Stuck - On (On older models)
X		X			21. Relay Stuck - Off (On older models)
X		X			22. Transformer Burned Out (Older models)
X		X		X	23. Loose Wire in Power Unit
			X		24. A Hose Plugged into another Inlet
			X		25. P.C. Board Relay Stuck ON
		X			26. P.C. Board Transformer burned out
		X			27. LED Light

1. Power Cord - Make sure that the power cord is plugged into an operating receptacle of the proper voltage and current for your unit.

2. Push-to-Reset Circuit Breaker - If your unit has experienced an over current or extremely high temperature, the button will pop out. To reset, simply push the button in until it protrudes about 1/8 inch and stays in. If the breaker pops out again when the unit is used - call your service technician.

- 3. Circuit Breaker in House Panel** - Check your house breaker panel - If the circuit breaker is off, you may have too many appliances utilizing that circuit. For best results, your power unit should be on a separate circuit. Try to remove some of the extra circuit load by unplugging other devices. If the breaker continues to cut off - call your service technician.
- 4. Internal Thermal Switch in Unit** - If your unit comes equipped with an internal thermal switch and quits running, it may require 10 minutes to cool off before resetting itself.
- 5. Electrical Wall Outlet Plug** - Sometimes the electric wiring from the house breaker panel to the wall outlet plug can become loose or broken. Plug a lamp or another electric appliance into the outlet to assure that you are getting power. If not, call your electrical contractor.
- 6. Switch in the Wall Inlet Stuck in Off Position** - Plug your flexible hose into the other wall inlets - if your unit functions normally then the problem lies in the switch or remote control circuit to the inoperative inlet valve. The bolts holding the micro-switch in the inlet valve may have loosened allowing it to move out of position. Remove the wall inlet face plate and tighten the bolts or call your service man.
- 7. Switch in the Wall Inlet Stuck in On Position** - Use your finger to roll the steel ball located in the top of the neck of the inlet. Some foreign material may have become lodged in the hole with the ball, preventing it from moving into its proper position. **Caution: if this procedure does not turn your unit off, unplug the power cord and notify your service technician.**
- 8. Remote Control Wire - Broken** - Usually, if more than one wall inlet is inoperative, the trouble is in the remote control wiring, and the wire is either loose or broken, and should be tightened or replaced.
- 9. Remote Control Wire - Shorted** - Unplug one of the remote control wires that is attached to the side of the power unit - if the unit stops, it indicates that the remote control wire is shorted or one of the wall inlet switches is stuck in the on position. If the procedure for number 6 does not shut the unit off and you cannot locate the short, notify your service man. If the unit does not stop running when you unplug the remote control wire - either the short is in the power unit wiring or the relay is stuck. Refer to number 20. **Caution: Checking the wiring in the power unit should only be attempted by a qualified service technician.**
- 10. Flexible Hose - Plugged** - If proper airflow is not obtained through the hose, remove the hose from the vacuum inlet, then start the power unit by activating the wall inlet switch. If the airflow, at the inlet, is good, then this will normally indicate a blockage in the hose or wand. If blockage is in the wand, it can be disassembled and cleaned. If blockage is in the hose, the hose should first be laid out straight, then with the hose plugged into the inlet valve and the power unit running, pick up the hose, starting at the end furthest from the valve and gently stretch about two feet of it at a time as you proceed along the length of the hose toward the inlet valve. If this does not clear the stoppage, then remove the hose cuffs by unscrewing them, and switch them to the other ends of the hose (these cuffs have left hand screw threads so rotate them in a clockwise direction to unscrew from the hose). After this has been done replace the hose in the inlet valve and with the power unit operating, repeat the process of stretching the hose. If this fails to unclog the hose, run (handle first) a screwdriver with at least a 3/4" diameter handle through the hose.
- 11. Tubing in Wall - Clogged** - Check the airflow at the power unit. If the airflow is good here but not at locations further from the power unit, your tubing is either clogged or has broken open. If you cannot repair this, contact your service man. If you turn the power unit on and leave the inlet valve furthest from the power unit open and then check the exhaust from the power unit, you can determine whether you have a break in the tubing or whether the tubing is clogged. If very little air is coming out of the exhaust of the power unit, then it is probably an obstruction in the tubing and not a break.

12. Dirt Canister - Over Filled - Whenever low airflow is experienced the first thing to check is the dirt canister for over filling or clogged filter bag (some models). Refer to Number 13. Read the Operations section of this manual for information on how to clean your dirt canister.
13. Filter Bag - Clogged (some models) - Read the Operations section of this manual for information on how to remove and clean your filter bag.
14. Dirt Canister Lid - Off - On those models with lift off dirt canister lids, (check the Operations section of this manual) the lid must be replaced squarely on top of the canister or it will allow a vacuum leak.
15. Dirt Canister Gasket - Loose - If the dirt canister gasket has been pulled loose, it will allow a vacuum leak. The gasket may be reattached with contact cement or any of the so called "super glues".
16. Outside Exhaust - Blocked - Check the exhaust system by removing the tubing from the motor blower exhaust and comparing the airflow at this point versus the airflow reaching the outside. If blockage is detected and cannot be removed, contact your service technician.
17. Dirt Canister - Not Attached - If the dirt canister latches (some models) are not properly closed, it will cause an air leak along the gasket and reduce your cleaning ability.
18. Another Wall Inlet Door - Open - Check all the inlet valves to make sure that only one inlet is in use at a time. Attempting to clean from two or more inlets at a time will reduce the airflow below the level required to deep clean your carpets.
19. Motor Protection Screen - Clogged - This usually occurs due to allowing the dirt canister to over fill, or a broken filter bag (some models). Refer to the Operations section of this manual for instructions on cleaning the blower protection screen.
20. Relay Stuck - On - Refer to Number 9. If after using the procedures described in Number 9 it appears that the relay is sticking on, unplug the power cord to cut off all electricity to the power unit. **Caution: Checking the wiring in the power unit should only be attempted by a qualified service technician.**
21. Relay Stuck - Off - If the procedures described in Numbers 1, 2, 3, 4, 5, 6 or 7, do not correct the power unit not starting, then it could be a malfunction of the relay, the low voltage transformer could be burned out, or there could be a loose wire in the power unit. If you suspect a malfunction in the power unit, contact your service technician.
22. Transformer - Burned Out - Refer to Number 21.
23. Loose Wire In the Power Unit - Refer to Number 21.
24. A Hose Plugged Into Another Inlet Valve - Cleaning from more than one inlet at a time will reduce the airflow to less than is required to deep clean your carpets.
25. P.C. Board Relay stuck on - Refer to Number 9. If after using the procedures described in Number 8 it appears that the relay is sticking on, unplug the power cord to cut off all electricity to the power unit. **Caution: Checking the wiring in the power unit should only be attempted by a qualified service technician.**
26. P.C. Board Transformer burned out - If the procedures described in Numbers 1, 2, 3, 4, 5, 6 or 7, do not correct the power unit not starting, then it could be a malfunction of the relay, the low voltage transformer could be burned out, or there could be a loose wire in the power unit. If you suspect a malfunction in the power unit, contact your service technician.
27. LED Light - Some units have an LED light at the unit. If the LED light is not on, refer to number 5. If you have power at the unit but LED light is off, contact your local service technician.

IF YOU CANNOT DIAGNOSE OR REPAIR YOUR TROUBLE,
CONTACT THE NEAREST DISTRIBUTOR.

LIMITED* FIVE or SEVEN or TEN YEAR WARRANTY

This Warranty gives you specific legal rights, you may also have other rights which vary from State to State (or Province).

ITEMS COVERED

Your Imperium system is hereby warranted against defects in material and workmanship which occur during the term of this Warranty. Your system either carries a five-year or seven-year warranty, depending on the unit model purchased. The five (5) or seven (7) or ten (10) year term of this Warranty shall commence upon installation of the power unit. Any warranted defects will be replaced and repaired without cost to the customer except for transportation charges and/or charges associated with removal and reinstallation. This Warranty is given only to the original owner. Please refer to IMPERIUM for the warranty applicable to your particular model.

ITEMS NOT COVERED

This Warranty does not cover such conditions as normal wear to the power unit resulting from normal usage or from damage caused by accidents, negligence, misuse, or improper alteration, or from damage by fire, flood, or other acts of God. Motor brush wear is normal and is not considered to be a defect in material or workmanship. Further, this Warranty does not apply to vacuum tubing, fittings, wall inlets, flexible hoses, wands and cleaning tools, or to the act of installing the IMPERIUM Central Vacuum Systems.

TERMS OF WARRANTY AND RESTRICTIONS

*The five (5) year or (7) seven or ten (10) year term of this limited Warranty is effective for single family residential applications only. In commercial/industrial applications, this limited warranty is valid for ninety (90) days only from the date of installation. In all applications, this warranty shall be for the benefit only of the original owner of the Imperium Central Vacuum System.

REQUIRED REGISTRATION

Included with the papers which accompany the IMPERIUM product is a Warranty registration card. The Warranty registration card must be completed and returned to us within thirty (30) days of when the original consumer acquires the IMPERIUM products. IF THE WARRANTY REGISTRATION CARD IS NOT RETURNED WITHIN THIS TIME, THIS WARRANTY SHALL BE VOID AND OF NO EFFECT.

HOW TO INVOKE THIS WARRANTY

To invoke your rights under this Warranty you must notify your Imperium dealer within forty-five (45) days of when you became aware that a defect exists which is covered by this Warranty. In any correspondence with our factory, please refer to the serial number for your IMPERIUM power unit. This serial number is found on the label attached to the power unit.

If it should ever become necessary to invoke the rights and privileges of this Warranty during the period of effectiveness the following procedures should be followed:

- a) Refer to operating maintenance instructions to ascertain that a malfunction of the power unit has actually occurred.
- b) Notify the authorized IMPERIUM distributor-installer who sold the unit, that you have a problem and describe the nature of your difficulty.
- c) If the IMPERIUM distributor-installer has not solved your problem within a reasonable time (but in all events within 45 days of when you became aware of a defect), write or call IMPERIUM.

DISCLAIMER OF OTHER WARRANTIES

IMPERIUM INDUSTRIES, HEREBY DISCLAIMS ALL LIABILITY WHATSOEVER FOR ANY INCIDENTAL OR CONSEQUENTIAL DAMAGES WHICH OCCURS AS A RESULT OF DEFECTS IN MATERIAL AND WORKMANSHIP IN THE PRODUCT. IMPERIUM, ALSO HEREBY DISCLAIMS ALL IMPLIED WARRANTIES, INCLUDING THE WARRANTIES OF MERCHANTABILITY AND FITNESS FOR A PARTICULAR PURPOSE.

SOME STATES (or provinces) DO NOT ALLOW THE EXCLUSION OR LIMITATION OF INCIDENTAL OR CONSEQUENTIAL DAMAGES, SO THE ABOVE LIMITATION OR EXCLUSION MAY NOT APPLY TO YOU. SOME STATES (or provinces) DO NOT ALLOW LIMITATIONS ON HOW LONG AN IMPLIED WARRANTY LASTS, SO THE ABOVE LIMITATIONS MAY NOT APPLY TO YOU. TO THE EXTENT THAT ANY LAW PROHIBITS, IN WHOLE OR PART, THE LIMITATION OF IMPLIED WARRANTIES, ANY IMPLIED WARRANTY APPLICABLE TO THE PRODUCT SHALL NOT EXCEED A PERIOD OF FIVE (5) or SEVEN (7) YEARS or TEN (10) FOR SINGLE RESIDENTIAL APPLICATIONS OR 90 DAYS FOR COMMERCIAL/INDUSTRIAL APPLICATIONS.

This warranty is exclusive and is in lieu of all other expressed warranties, and in lieu of all other obligations or liabilities on the part of IMPERIUM, for damage to person or property. We do not authorize any person, including any dealer, agent, supplier, or representative of IMPERIUM, to make any other warranty or guarantee on our behalf, or assume for us any liability on the IMPERIUM Central Vacuum System other than that contained herein. No oral representations regarding warranty shall be binding upon IMPERIUM, whether extended before or after sale of that product.

Central Vacuum Stores • 11236 47th St N Clearwater, FL 33762 • 1-800-221-8227

SERIAL NUMBER LOCATION FOR CENTRAL VACUUM SYSTEM

- IMPORTANT -

The serial number for your wall mounted central vacuum system can be found on the serial label. This label will be found on the left or right side of the unit near the top and close to the wall.

Example Label

Yours may differ

Mount at least 6" from side walls and ceiling
Monter au moins à 6" du plafond et des murs adjacents

SCAN QR CODE FOR SERVICE INFO





C US

Cleaning Machine
Household Type
167136
Aspirateur Central

Model / Modèle #
SR38 (CV300)
Serial # / Numéro de Série
S0342749CCV300
Date
March-2014
Amps
12.5
Volts Hertz
120 60

Centralvacuumstores.com 1-800-221-8227 Class 2 Not Wet 24 Volts

Lindsay Manufacturing, Inc Made in USA Connect to Individual Branch Circuit

Model

Serial #

Scan the QR code on your unit label with a smartphone QR scanner app and it will take you directly to our website.

Imperium Maintenance Card

Keep a record of maintenance performed on your
Imperium Central Vacuum

Date	Timer Reading	Maintenance Performed

TIPS ON THE CARE OF YOUR CENTRAL VACUUM SYSTEM

Your power unit is warranted against defective materials and workmanship but not against misuse. There is a service charge for repairing or replacing damaged or misused components of the system or for unnecessary service calls. Your built-in system is a lifetime improvement for you and your family. Follow these simple tips and you will enjoy it for many years:

1) DO NOT PLACE ANYTHING ON TOP OF THE POWER UNIT

To do so would cause the motor to overheat as it will impair the cooling air flow.

2) DO NOT OVERFILL YOUR DIRT CANISTER

Allowing the dirt canister to fill up to the bottom of the plastic cone will nullify the cyclonic separator system and could cause debris to be drawn into the upper screen which may, in time, damage your power unit.

3) USE ONE INLET AT A TIME TO MAINTAIN PROPER AIR FLOW

Using more than one vacuum inlet at a time reduces the air flow to a level below that which is required to effectively deep clean your carpets.

4) STORE YOUR HOSE AND TOOLS PROPERLY

When not in use, always hang up your hose and store the cleaning tools and wands in a place where they will not be damaged.

5) HOLD THE INLET DOOR OPEN WHEN REMOVING THE HOSE

After removing the hose from the inlet, hold the inlet door open for a few seconds to:

- a) Make sure the unit has stopped.
- b) Clear any residual dirt out of the vacuum tubing

6) DO NOT PICK UP ANY LIQUIDS

Do not pull liquids into the vacuum tubing since any liquid left in the tubing may:

- a) Drain back out of the wall inlet and cause streaking of the walls.
- b) Cause dirt build-up in the tubing that could eventually clog the system.

Wet Pick-up Units are available for this type of use.

Contact Central Vacuum Stores.

7) BE CERTAIN TO REGISTER YOUR PRODUCT

Take just a few moments to fill out the warranty card, cut it out, place a stamp on it and drop it in the mail.

“We can’t thank you enough for your recent purchase from CentralVacuumStores.com. As a small business with 30 employee families to support, we appreciate each and every one of our customers.

We think you will find that our employees are experts in the central vacuum industry. They are not only have the most education, training and experience, but they are, without a doubt, the nicest and most helpful folks you could ever want to talk to!

So, if you have any problems or questions, please call us a 1-800-221-8227...and visit us again at www.centralvacuumstores.com”

-Roger & Renee Ambrose

IMPERIUM
CENTRAL VACUUM SYSTEMS. *When only the best will do.*